

RECOM

We've got the Power.

HIGH POWER WHITE LIGHT
CONSTANT CURRENT
LED-DRIVERS



DROP IN REPLACEMENT FOR
3-PIN REGULATORS (78 SERIES)
**R-78 SWITCHING
REGULATORS**

100% POWER. NO DERATING.
HIGH EFFICIENCY HIGH TEMP. DC-
DC POWER MODULES

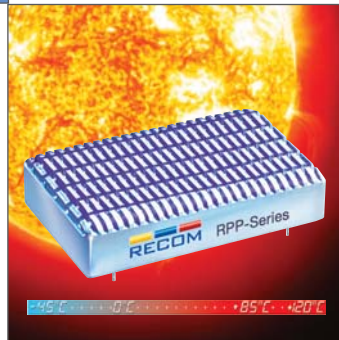

MICROSIZE PCB MOUNT
SAFETY APPROVED
AC-DC MODULES

Catalogue

2014

ECONOLINE - Unregulated

RECOM

Series	Power (Watts)	Isolation (kVDC)	Input Voltages (VDC)	Output Voltages (VDC)	No. of Outputs	Case	Page No.
RM	0.25	1 & 2	3.3, 5, 12, 15, 24	3.3, 5, 9, 12, 15	S	SIP4	E-2
RM/E	0.25	1 & 2	3.3, 5, 12	5	S	SIP4	E-4
ROL	0.5	1 & 2	5, 12	5, 12, 15	S	SIP4	E-6
R0.25S	0.25	1 & 3	3.3, 5, 12, 15, 24	3.3, 5, 9, 12, 15, 24	S	SMD	E-8
R0.25D				$\pm 3.3, \pm 5, \pm 9, \pm 12, \pm 15, \pm 24$	D		
R0.25DA				5/5, 12/12	D (isol)		
R0.25S/E	0.25	1 & 2	3.3, 5, 12	5	S	SMD	E-12
RBL/E	0.25	1 & 2	3.3, 5, 12	5	S	SIP7	E-14
R0.5S_D	0.5	1 & 3	3.3, 5, 12, 24	5, 12, 15	S	SMD	E-16
				$\pm 5, \pm 12, \pm 15$	D		
R1S	1	1 & 3	3.3, 5, 12, 15, 24	3.3, 5, 9, 12, 15, 24	S	SMD	E-24
R1D				$\pm 3.3, \pm 5, \pm 9, \pm 12, \pm 15, \pm 24$	D		
R1S/E	1	1 & 2	3.3, 5, 12, 24	± 5	S	SIP4	E-28
R1SE	1	1	5	5	S	SMD	E-30
RNM	1	1 & 2	3.3, 5, 12, 15	3.3, 5, 9, 12, 15	S	DIP4	E-32
ROM	1	3	5, 12	5, 12, 15	S	SIP4 Micro	E-35
RO	1	1 & 2	3.3, 5, 12, 15, 24	3.3, 5, 9, 12, 15, 24	S	SIP4	E-37
RO/E	1	1 & 2	3.3, 5, 12, 24	± 5	S	SIP4	E-39
ROE	1	1	5	5	S	SIP7	E-41
RBM	1	3	5, 12	5, 12, 15	S	SIP6 Micro	E-43
				$\pm 5, \pm 12, \pm 15$	D		
RB	1	1 & 2	3.3, 5, 12, 15, 24	3.3, 5, 9, 12, 15, 24	S	SIP7	E-46
				$\pm 3.3, \pm 5, \pm 9, \pm 12, \pm 15, \pm 24$	D		
RB/E	1	1 & 2	3.3, 5, 12, 24	± 5	S	SIP7	E-49
RBE	1	1	5	5	S	SIP7	E-51
RE	1	1 & 2	3.3, 5, 12, 15, 24	3.3, 5, 9, 12, 15, 24	S	SIP7	E-53
REE	1	1	5	5	S	SIP7	E-55
RK	1	3 & 4	5, 12, 15, 24	5, 9, 12, 15	S	SIP7	E-57
RH				$\pm 5, \pm 9, \pm 12, \pm 15$	D		
RKE/H	1	3 & 4	5	5	S	SIP7	E-60
RAM	1	3 & 4	3.3, 5, 12	5	S	SMD	E-62
RAZ	1	1 & 2	3.3, 5, 12	5	S	SMD	E-64
RP	1	5.2	5, 9, 12, 15, 24	3.3, 5, 9, 12, 15, 24	S	SIP7	E-66
				$\pm 3.3, \pm 5, \pm 9, \pm 12, \pm 15, \pm 24$	D		
RxxPxx	1	6.4	5, 9, 12, 15, 24	3.3, 5, 9, 12, 15	S	SIP7	E-69
				$\pm 3.3, \pm 5, \pm 9, \pm 12, \pm 15$	D		
RxxPxx/R	1	R6.4, R8	5, 9, 12, 15, 24	3.3, 5, 9, 12, 15	S	SIP7	E-73
				$\pm 3.3, \pm 5, \pm 9, \pm 12, \pm 15$	D		
R1DA	1	1 & 3	3.3, 5, 12, 15, 24	$\pm 3.3, \pm 5, \pm 9, \pm 12, \pm 15$	D	SMD	E-76
RU	1	1 & 2	3.3, 5	5/5	D (isol.)	SIP7	E-79
RUM	1	1 & 2	3.3, 5	5/5	D (isol.)	SIP6	
RN	1.25	1 & 2	3.3, 5, 12, 15, 24	3.3, 5, 12, 15, 24	S	DIP8	E-81
RTM	2	2 & 3	5, 12, 24	5	S	SMD	E-83
R2S	2	1 & 3	5, 12, 15, 24	3.3, 5, 9, 12, 15, 24	S & D	SMD	E-85
R2D				$\pm 5, \pm 9, \pm 12, \pm 15, \pm 24$	D		
RI	2	1	5, 12, 15, 24	5, 12, 15	S	SIP4	E-89
RD	2	1 & 2	5, 12, 24	$\pm 5, \pm 12, \pm 15$	D	SIP7	E-91
RKZ	2	3 & 4	5, 12	5, 12, 15	S	SIP7	E-93
				$\pm 5, \pm 12, \pm 15$	D		
RxxP2xx	2	5.2	5, 12, 15, 24	3.3, 5, 9, 12, 15	S	SIP7	E-96
				$\pm 3.3, \pm 5, \pm 9, \pm 12, \pm 15$	D		
RxxP2xx/R	2	R6.4, R8	5, 12, 15, 24	3.3, 5, 9, 12, 15	S	SIP7	E-100
				$\pm 3.3, \pm 5, \pm 9, \pm 12, \pm 15$	D		
RUZ	2	1 & 2	5	5/5	D (isol.)	SIP7	E-104
RJZ	2	3 & 4	3.3, 5, 9, 12, 15, 24	3.3, 5, 9, 12, 15, 24	S	DIP14	E-106
RGZ				$\pm 3.3, \pm 5, \pm 9, \pm 12, \pm 15$	D		
RV	2	5.2	3.3, 5, 9, 12, 15, 24	3.3, 5, 9, 12, 15, 24	S	DIP24 Miniature	E-109
				$\pm 3.3, \pm 5, \pm 9, \pm 12, \pm 15; \pm 24$	D		
RV/R	2	R6.4, R8	3.3, 5, 9, 12, 15, 24	3.3, 5, 9, 12, 15, 24	S	DIP24 Miniature	E-113
				$\pm 3.3, \pm 5, \pm 9, \pm 12, \pm 15; \pm 24$	D		

ECONOLINE - Regulated

RECOM

Series	Power (Watts)	Isolation (kVDC)	Input Voltages (VDC)	Output Voltages (VDC)	No. of Outputs	Case	Page No.
RO.5Z	0.5	1	5, 12, 15, 24	5, 12, 15	S	SMD	E-117
R1Z	1	1 & 2	3.3, 5, 12, 15, 24	3.3, 5, 9, 12	S	SMD	E-119
RY	1	1	5, 9, 12, 15, 24	5, 9, 12, 15, 24 ±5, ±9, ±12, ±15, ±24	S D	SIP7	E-121
RY-SCP_DCP	1	1	5, 9, 12, 15, 24	5, 9, 12, 15, 24 ±5, ±9, ±12, ±15, ±24	S D	SIP7	E-123
RSO-S	1	1, 2 & 3	4.5-9, 9-18, 18-36, 36-72	3.3, 5, 9, 12, 15	S	SIP8	E-125
RSO-D				±3.3, ±5, ±9, ±12, ±15	D		
RSO-SZ			4.5-18, 9-36, 18-72	3.3, 5, 9, 12, 15	S		
RSO-DZ				±3.3, ±5, ±9, ±12, ±15	D		
RS-S	2	1, 2 & 3	4.5-9, 9-18, 18-36, 36-72	3.3, 5, 9, 12, 15	S	SIP8	E-128
RS-D				±3.3, ±5, ±9, ±12, ±15	D		
RS-SZ			9-36, 18-72	3.3, 5, 9, 12, 15	S		
RS-DZ				±3.3, ±5, ±9, ±12, ±15	D		
RW2	2	1, 2 & 3	4.5-9, 9-18, 18-36, 36-72	3.3, 5, 9, 12, 15 ±3.3, ±5, ±9, ±12	S D	DIP16/SMD	E-131
RS3-S	3	1, 2 & 3	4.5-9, 9-18, 18-36, 36-72	3.3, 5, 9, 12, 15	S	SIP8	E-133
RS3-D				±3.3, ±5, ±9, ±12, ±15	D		
RS3-SZ			9-27, 20-60	3.3, 5, 9, 12, 15	S		
RS3-DZ				±3.3, ±5, ±9, ±12, ±15	D		
RW-S	3	1	4.5-9, 9-18, 18-36, 36-72	3.3, 5, 9, 12, 15	S	DIP24/SMD (Miniature)	E-136
RW-D	3	3	4.5-9, 9-18, 18-36, 36-72	±5, ±9, ±12, ±15	D	DIP24 (Miniature)	E-139
REC3-SR/H1	3	1	5, 12, 24	5, 12, 15,	S	DIP24	E-141
REC3-DR/H1				±5, ±12, ±15	D		
REC3-SRW/H*	3	(1.6) 2, 4 & 6	4.5-9, 9-18, 18-36, 36-72	3.3, 5, 9, 12, 15	S	DIP24/SMD	E-143
REC3-DRW/H*				±3.3, ±5, ±9, ±12, ±15	D		
REC3-SRWZ/H*			9-36, 18-72	3.3, 5, 9, 12, 15	S		
REC3-DRWZ/H*				±3.3, ±5, ±9, ±12, ±15	D		
REC3.5-SRW/R*	3.5	R8 & R10	4.5-9, 9-18, 18-36, 36-75	5, 9, 12, 15, 24	S	DIP24/SMD	E-147
REC3.5-DRW/R*				±5, ±9, ±12, ±15	D		
REC5-SRW/H*	5	(1.6) 2, 4 & 6	4.5-9, 9-18, 18-36, 36-72	3.3, 5, 9, 12, 15	S	DIP24/SMD	E-151
REC5-DRW/H*				±5, ±9, ±12, ±15	D		
REC5-SRWZ/H*			9-36, 18-72	3.3, 5, 9, 12, 15	S		
REC5-DRWZ/H*				±5, ±9, ±12, ±15	D		
REC6-SRW/R*	6	R8 & R10	4.5-9, 9-18, 18-36, 36-75	5, 9, 12, 15, 24	S	DIP24/SMD	E-155
REC6-DRW/R*				±5, ±9, ±12, ±15	D		
REC7.5-SRW/H*/A/M	7.5	1, 2 & 3	9-18, 18-36, 36-72	3.3, 5, 9, 12, 15	S	DIP24/SMD	E-159
REC7.5-DRW/H*/A/M				±5, ±9, ±12, ±15	D		
REC8-SRW/H*/A/M	8	2 & 3	4.5-9, 9-18, 18-36, 36-75	3.3, 5, 12, 15	S	DIP24/SMD	E-162
REC8-DRW/H*/A/M				±5, ±12, ±15	D		
REC8-SRWZ/H*/A/M			9-36, 18-75	3.3, 5, 12, 15	S		
REC8-DRWZ/H*/A/M				±5, ±12, ±15	D		
REC10-SRW/H*/A/M	10	2 & 3	9-18, 18-36, 36-75	3.3, 5, 12, 15	S	DIP24/SMD	E-165
REC10-DRW/H*/A/M				±5, ±12, ±15	D		
REC10-SRWZ/H*/A/M			9-36, 18-75	3.3, 5, 12, 15	S		
REC10-DRWZ/H*/A/M				±5, ±12, ±15	D		
REC10-S/H*/M	10	2 & 3	9-18, 18-36, 36-75	3.3, 5, 12, 15	S	2"x 1"	E-168
REC10-D/H*/M				±5, ±12, ±15	D		
REC10-SZ/H*/M			9-36, 18-75	3.3, 5, 12, 15	S		
REC10-DZ/H*/M				±5, ±12, ±15	D		
REC15-SRW/H*/A/M	15	2 & 3	9-18, 18-36, 36-75	3.4, 5.1, 12, 15	S	2"x 1"	E-170
REC15-DRW/H*/A/M				±5, ±12, ±15	D		

Features

Unregulated Converter

- Single Output Rail
- Industry Standard Pinout
- 1kVDC or 2kVDC Isolation
- High Efficiency for Low Power Applications
- UL94V-0 Package Material
- Optional Continuous Short Circuit Protected
- Fully Encapsulated
- Custom versions available
- Efficiency to 76%

Description

The RM series DC/DC converter has been designed for isolating or converting DC power rails with very light loads. Efficiencies are typically 10% higher than a comparable 0.5W or 1W converters run at the same low load.

Selection Guide

Part Number SIP 4	(2kV)	Input Voltage (VDC)	Output Voltage (VDC)	Output Current (mA)	Efficiency (%)	Max. Capacitive Load ⁽¹⁾
RM-xx3.3S	(H)	3.3, 5, 12, 15, 24	3.3	76	65-70	1000µF
RM-xx05S	(H)	3.3, 5, 12, 15, 24	5	50	66-72	470µF
RM-xx09S	(H)	3.3, 5, 12, 15, 24	9	28	70-72	470µF
RM-xx12S	(H)	3.3, 5, 12, 15, 24	12	21	70-72	150µF
RM-xx15S	(H)	3.3, 5, 12, 15, 24	15	17	70-76	150µF

xx = Input Voltage (other input and output voltage combinations and output powers available on request)

* add Suffix "P" for Continuous Short Circuit Protection, e.g. RM-0505S/P, RM-0505S/HP

Specifications (measured at T_A = 25°C, nominal input voltage, full load and after warm-up)

Input Voltage Range			±10%
Output Voltage Accuracy			±5%
Line Voltage Regulation			1.2%/1% of Vin typ.
Load Voltage Regulation (10% to 100% full load)	3.3V output types		20% max.
	5V output type		15% max.
	12V, 15V, 24V output types		10% max.
Output Ripple and Noise (20MHz limited)			50mVp-p max.
Operating Frequency			50kHz min. / 90kHz typ. / 105kHz max.
Efficiency at Full Load			65% min. / 75% typ.
Minimum Load = 0%	Specifications valid for 10% minimum load only.		
Isolation Voltage	(tested for 1 second)		1000VDC
	(rated for 1 minute**)		500VAC / 60Hz
Isolation Voltage	H-Suffix	(tested for 1 second)	2000VDC
	H-Suffix	(rated for 1 minute**)	1400VAC / 60Hz
Isolation Capacitance			25pF min. / 82pF max.
Isolation Resistance			10 GΩ min.
Short Circuit Protection			1 Second
P-Suffix			Continuous
Operating Temperature Range (free air convection)			-40°C to +85°C (see Graph)
Storage Temperature Range			-55°C to +125°C
Relative Humidity			95% RH
Package Weight	RM types		1.4g
	RL types		1.8g
Packing Quantity			42 pcs per Tube
MTBF (+25°C) (+85°C)	} Detailed Information see Application Notes chapter "MTBF"	using MIL-HDBK 217F	1327 x 10 ³ hours
		using MIL-HDBK 217F	302 x 10 ³ hours

continued on the next page

**Any data referred to in this datasheet are of indicative nature and based on our practical experience only. For further details, please refer to our Application Notes.

ECONOLINE

DC/DC-Converter

with 3 year Warranty

RECOM

0.25 Watt

SIP4

Single Output



E358085

EN-60950-1 Certified
UL-60950-1 Certified
IEC/EN-60601-1 Certified*
 * (/H suffix)

RM

Derating-Graph (Ambient Temperature)

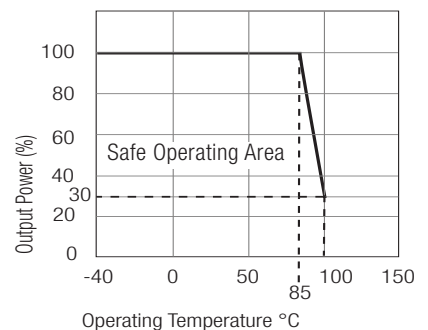

Specifications (measured at $T_A = 25^\circ\text{C}$, nominal input voltage, full load and after warm-up)

Certifications

UL General Safety	Report: E358085	UL 60950-1, 2nd Edition
EN General Safety	Report: SPCLVD1109103	EN 60950-1:2006 + A12:2011
EN Medical Safety	Report: MDD1112018 + RM1112018	IEC/EN 60601-1 3rd Edition Medical Report + ISO14971 Risk Assessment

Typical Characteristics

RM-xx05S

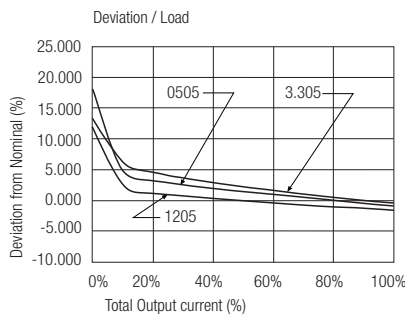
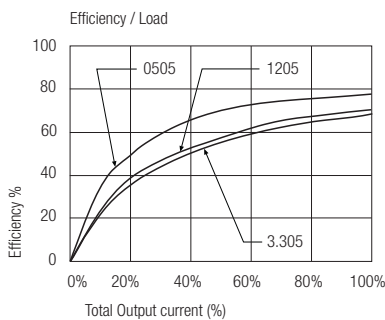

RM-xx12S

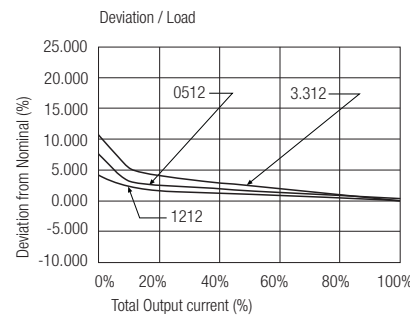
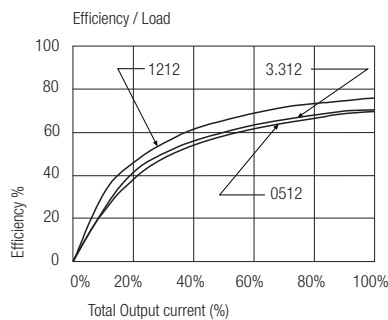

RM-xx15S

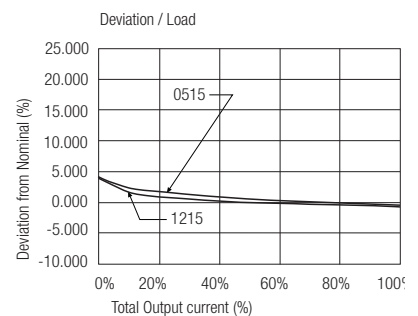
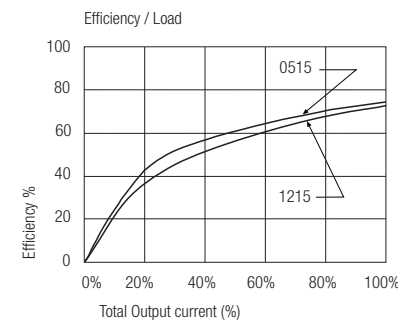

Notes

Note 1 Maximum capacitive load is defined as the capacitive load that will allow start up in under 1 second without damage to the converter.

Package Style and Pinning (mm)

4 PIN SIP Package

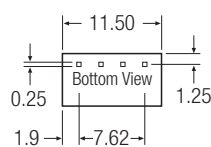
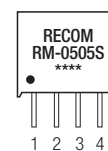
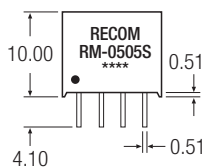

Recommended Footprint Details

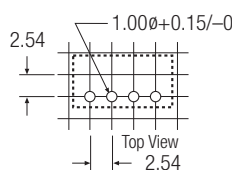

RM Pin Connections

Pin #	Single
1	-Vin
2	+Vin
3	-Vout
4	+Vout

XX.X ± 0.5 mm
XX.XX ± 0.25 mm

Features

Unregulated Converter

- 1 : 1 Input Range
- 0.25W SIP4 Package
- Efficiency up to 82%
- 1kVDC and 2kVDC Isolation Option
- Operating Temperature from -40°C to +100°C

Description

The RM/E series DC/DC converter has been designed to offer exceptionally high efficiency, low quiescent current and an extended operating temperature range. Uses include battery powered supplies, high efficiency designs or high temperature applications.

Selection Guide

Part Number SMD	Input Voltage (VDC)	Output Voltage (VDC)	Output Current (mA)	Efficiency typ. (%)	Max Capacitive Load ⁽¹⁾ **
RM-3.305S/E*	3.3	5	50	80	1000µF
RM-0505S/E*	5	5	50	82	1000µF
RM-1205S/E*	12	5	50	78	1000µF

Other input and output voltage combinations available on request

*add Suffix „H“ for 2 kVDC Isolation, e.g. RM-3.305S/HE

Specifications (measured at T_A = 25°C, nominal input voltage full load and after warm-up)

Input Voltage Range		±10% max.
Voltage set accuracy	100% Load/nominal Vin	-2% typ. / ±5% max.
Line Regulation	Low Line to High Line @ max. Load	1,2% typ.
Load Regulation	(10% to 100% Load)	4% typ. / 10% max.
Ripple & Noise @ 20MHz BW	RM-3.305S/E others	35mVp-p typ. / 60mVp-p max. 35mVp-p typ. / 50mVp-p max.
Efficiency	100% Load	70% min.
Operating Temperature		-40°C to + 100°C
Storage Temperature		-55°C to +125°C
Isolation Voltage	(tested for 1 second) (rated for 1 minute**)	1000VDC 500VAC / 60Hz
Isolation Voltage	H-Suffix (tested for 1 second) H-Suffix (rated for 1 minute**)	2000VDC 1000VAC / 60 Hz
Isolation Capacitance		75PF max.
Isolation Resistance	Viso = 500V	10 GΩ min.
Humidity		95% max.
Operating Frequency	Vin (nom.)	20kHz min. / 70 kHz max.
Short-Circuit Protection		1 Second
MTBF	Using MIL-HDBK 217F (+100°C) Using MIL-HDBK 217F (+25°C)	1352 x 10 ³ hours 4494 x 10 ³ hours
<i>Detailed Information see Application Notes chapter „MTBF“</i>		
Weight		1.4 g

**Any data referred to in this datasheet are of indicative nature and based on our practical experience only. For further details, please refer to our Application Notes.

Notes

Note1: Maximum capacitive load is defined as the capacitive load that will allow start up in under 1second without damage to the converter.

ECONOLINE

DC/DC-Converter

with 3 year Warranty

RECOM

0.25 Watt SIP4

Single Output

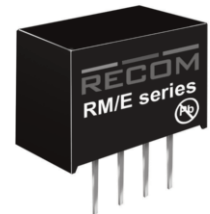

RM/E

Derating-Graph (Ambient Temperature)

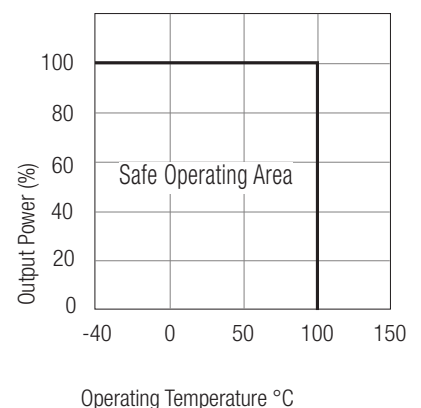

Refer to Application Notes

Typical Characteristics

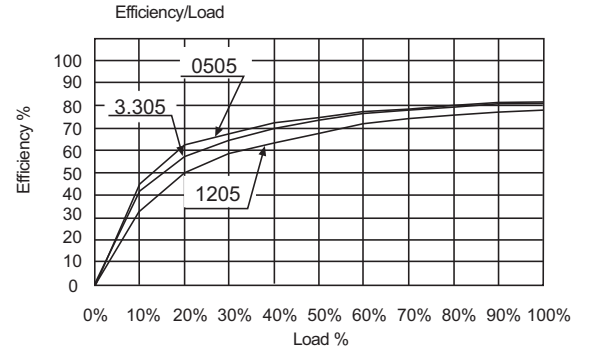
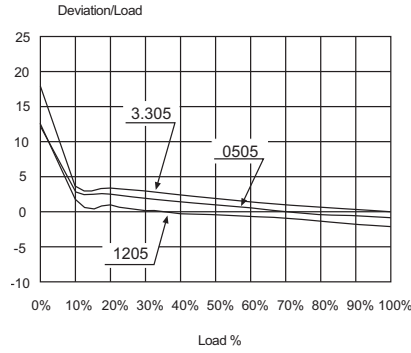
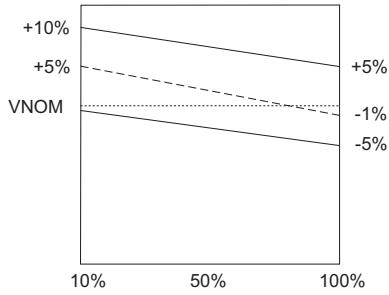

+Vout and -Vout load current (%)

Package Style and Pinning (mm)

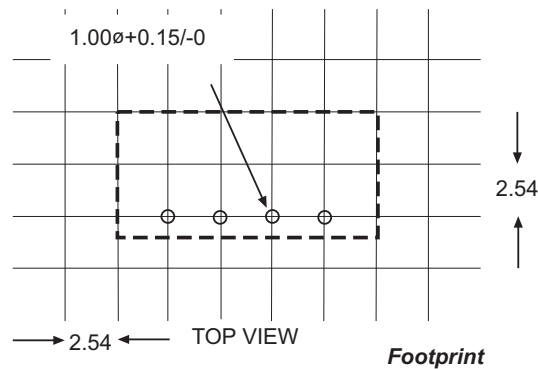
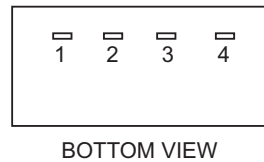
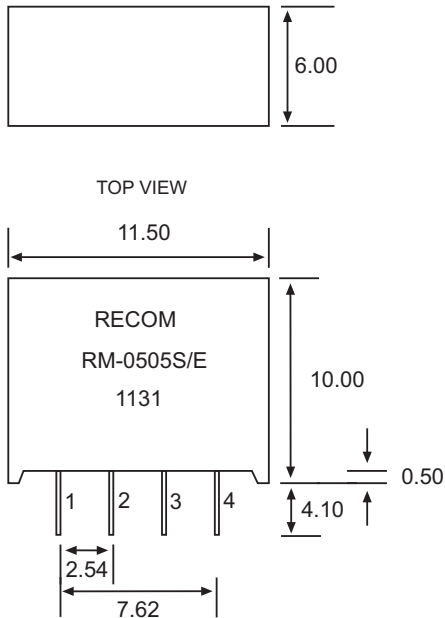

Pin Connections

Pin #	Function
1	-Vin
2	+Vin
3	-Vout
4	+Vout

UNIT: mm
TOL.: ± 0.25 mm

Features

Unregulated Converter

- Industry Standard Pinout
- 1kVDC or 2kVDC Isolation
- UL94V-0 Package Material
- Optional Continuous Short Circuit Protected
- Fully Encapsulated
- Custom Solutions Available
- Efficiency to 87%

Description The ROL DC/DC converters are typically used in general purpose low power isolation and voltage matching applications, and feature a full industrial operating temperature range of -40°C to +85°C without derating.

Selection Guide

Part Number	(2kV)	Input Voltage (VDC)	Output Voltage (VDC)	Output Current (mA)	Efficiency (%)	Max. Capacitive Load ⁽¹⁾
ROL-xx05S	(H)	5, 12	5	100	78-82	470µF
ROL-xx12S	(H)	5, 12	12	42	80-86	150µF
ROL-xx15S	(H)	5, 12	15	33	80-87	150µF

xx = Input Voltage (other input and output voltage combinations available on request)

* add Suffix "P" for Continuous Short Circuit Protection, e.g. ROL-0505S/P, ROL-0505S/HP

Specifications (measured at T_A = 25°C, nominal input voltage, full load and after warm-up)

Input Voltage Range		±10%	
Output Voltage Accuracy		±5%	
Line Voltage Regulation		1.2%/1% of Vin typ.	
Load Voltage Regulation (10% to 100% full load)		10% max. / 4% typ.	
Output Ripple and Noise (20MHz limited)		100mVp-p max.	
Operating Frequency		20kHz min. / 54kHz typ.	
Efficiency at Full Load		70% min. / 85% typ.	
Efficiency at 50% Load		65% min. / 80% typ.	
Minimum Load = 0%		Specifications valid for 10% minimum load only.	
Isolation Voltage	(tested for 1 second)	1000VDC	
	(rated for 1 minute**)	500VAC / 60Hz	
Isolation Voltage	H-Suffix (tested for 1 second)	2000VDC	
	H-Suffix (rated for 1 minute**)	1000VAC / 60Hz	
Isolation Capacitance		20pF min. / 75pF max.	
Isolation Resistance		10 GΩ min.	
Short Circuit Protection		1 Second	
P-Suffix		Continuous	
Operating Temperature Range (free air convection)		-40°C to +85°C (see Graph)	
Storage Temperature Range		-55°C to +125°C	
Relative Humidity		95% RH	
Package Weight		1.4g	
Packing Quantity		42 pcs per Tube	
MTBF (+25°C)	} Detailed Information see Application Notes chapter "MTBF"	using MIL-HDBK 217F	985 x 10 ³ hours
(+85°C)		using MIL-HDBK 217F	200 x 10 ³ hours
Certifications			
EN General Safety	Report: SPCLVD1109103	EN 60950-1:2006 + A12:2011	
UL General Safety	Report: E358085	UL 60950-1, 2nd Edition	

**Any data referred to in this datasheet are of indicative nature and based on our practical experience only. For further details, please refer to our Application Notes.

ECONOLINE

DC/DC-Converter

with 3 year Warranty

RECOM

0.5 Watt SIP4 Single Output

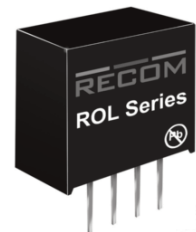

EN-60950-1 Certified
UL-60950-1 Certified

ROL

Derating-Graph (Ambient Temperature)

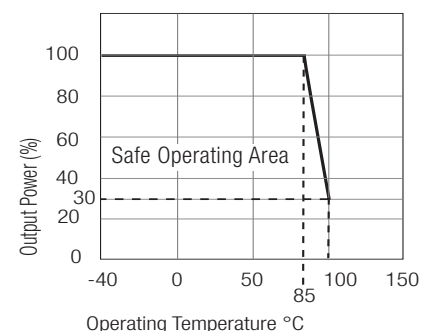

Refer to Application Notes

Typical Characteristics

ROL-0505S

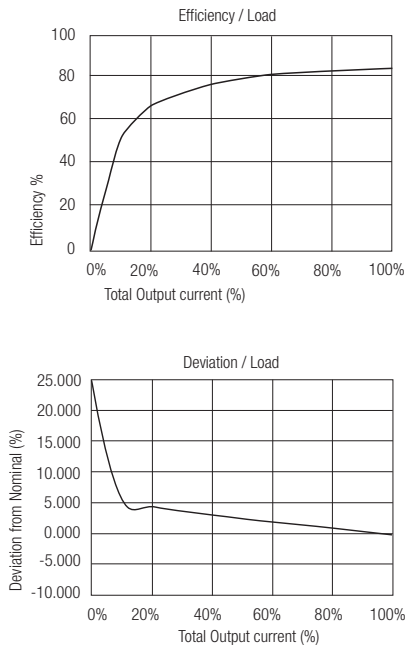

ROL-0515S

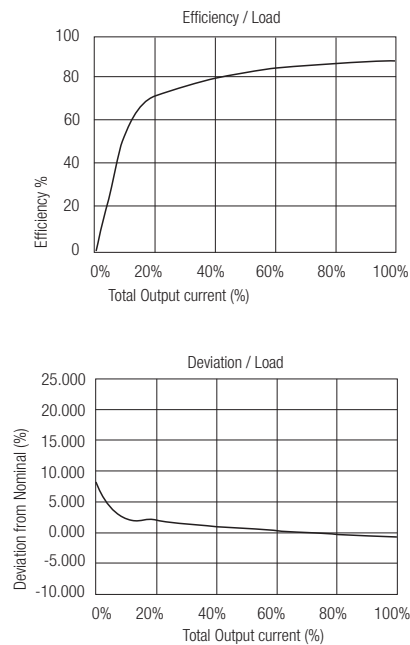

Notes
Note 1 Maximum capacitive load is defined as the capacitive load that will allow start up in under 1 second without damage to the converter.

ROL

Package Style and Pinning (mm)

4 PIN SIP Package

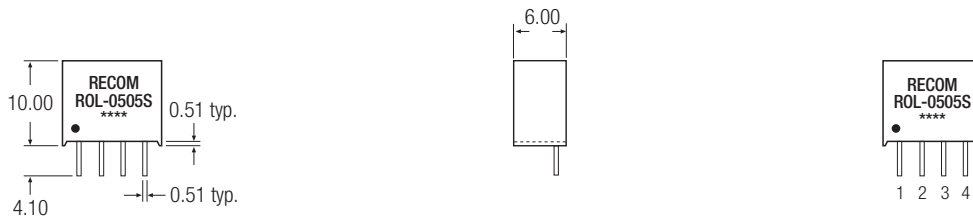

Recommended Footprint Details



ROL Pin Connections

Pin #	Single
1	-Vin
2	+Vin
3	-Vout
4	+Vout
XX.X	± 0.5 mm
XX.XX	± 0.25 mm

The product information and specifications are subject to change without prior notice. All products are designed for non-safety critical commercial and industrial applications. The Buyer agrees to implement safeguards that anticipate the consequences of any failures that might cause harm, loss of life and/or damage property.

Features

Unregulated Converters

- Fully RoHS 6/6 Conform
- Full Power at 100°C Ambient Temperature
- 1kVDC or 3kVDC Isolation Options
- Suitable for Fully Automated Assembly (including Vapour Phase Soldering)
- Optional Continuous Short Circuit Protection
- Built-In EN55022 Class A Filter

Description

The R0.25S and R0.25D converters are of the enclosed open frame type, i.e. they are not potted. The converters are typically used in general purpose and industrial low power isolation and voltage matching applications where an SMD converter is required. The converter series feature an extended ambient temperature operating range of -40°C to +100°C without derating and optional continuous short circuit protection. In addition to single, dual and independent outputs, two isolation options and three different case formats, the converters are also available prepacked as tape and reel for use with automatic insertion machines.

Selection Guide

Part Number SMD	(3kV)	Input Voltage (VDC)	Output Voltage (VDC)	Output Current (mA)	Capacitive Load (max.)
R0.25S**-xx3.3	(H)	3.3, 5, 12, 15, 24	3.3	76	1000µF
R0.25S**-xx05	(H)	3.3, 5, 12, 15, 24	5	50	470µF
R0.25S**-xx09	(H)	3.3, 5, 12, 15, 24	9	28	470µF
R0.25S**-xx12	(H)	3.3, 5, 12, 15, 24	12	21	150µF
R0.25S**-xx15	(H)	3.3, 5, 12, 15, 24	15	17	68µF
R0.25S**-xx24	(H)	3.3, 5, 12, 15, 24	24	10.4	68µF
R0.25D**-xx3.3	(H)	3.3, 5, 12, 15, 24	±3.3	±38	470µF
R0.25D**-xx05	(H)	3.3, 5, 12, 15, 24	±5	±25	220µF
R0.25D**-xx09	(H)	3.3, 5, 12, 15, 24	±9	±14	68µF
R0.25D**-xx12	(H)	3.3, 5, 12, 15, 24	±12	±10.4	68µF
R0.25D**-xx15	(H)	3.3, 5, 12, 15, 24	±15	±8.3	68µF
R0.25D**-xx24	(H)	3.3, 5, 12, 15, 24	±24	±5.2	33µF
R0.25DA**-xx0505		3.3, 5, 12, 15, 24	5/5	25/25	220µF/220µF
R0.25DA**-xx1212		3.3, 5, 12, 15, 24	12/12	10/10	68µF/68µF

xx = Input Voltage (other input and output voltage combinations available on request)

* add Suffix "H" for 3kV Isolation, e.g. R0.25S-0505/H, R0.25D-0505/H, R0.25S12-0505/H, R0.25D12-0505/H

* add Suffix "P" for Continuous Short Circuit Protection, e.g. R0.25S8-0505/P, R0.25S-0505/HP, R0.25D12-0505/HP

* add suffix -R for tape & reel packing e.g. R0.25S-0505-R. For more details see Application Notes.

Case and Pinning Options (note restrictions on /H option)

- R0.25S**: ** without marking denotes 5 pins out of 8 fitted (includes /H option)
 ** with marking **8** denotes 8 pins out of 8 fitted (/H option not available)
 ** with marking **12** denotes 10 pins out of 12 fitted (includes /H option)
- R0.25D**: ** without marking denotes 6 pins out of 10 fitted (includes /H option, no DA option)
 R0.25D(A): ** with marking **10** denotes with 10 pins out of 10 fitted (/H option not available)
 R0.25D(A): ** with marking **12** denotes 10 pins out of 12 fitted (includes /H option - except R0.25DA)

Specifications (measured at $T_A = 25^\circ\text{C}$, nominal input voltage, full load and after warm-up)

Input Voltage Range		±10%
Output Voltage Accuracy		±5% typ., ±7% max.
Line Voltage Regulation	(low line to high line at max. load)	2% max.
Load Voltage Regulation	3.3V output types	15% typ., 20% max.
(10% to 100% full load)	5V, 5/5V output types	12% typ., 15% max.
	9V output type	7% typ., 10% max.
	12V, 12/12V, 15V, 24V output types	6% typ., 10% max.
Output Ripple and Noise (20MHz BW limited)		100mVp-p max.
Operating Frequency		20kHz min. / 50kHz typ. / 90kHz max.

continued on next page

ECONOLINE

DC/DC-Converter

RECOM

0.25 Watt SMD Single, Dual & Independent Outputs



E358085

UL-60950-1 Certified
EN-60950-1 Certified
EN-60601-1 Certified*
 *(/H suffix)

R0.25S R0.25D(A)

Derating-Graph (Ambient Temperature)

Standard Case

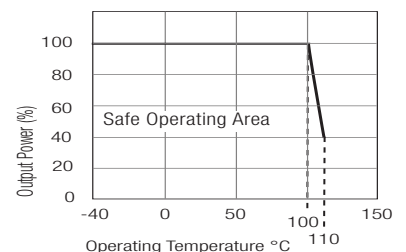

Big Case (with marking 12)

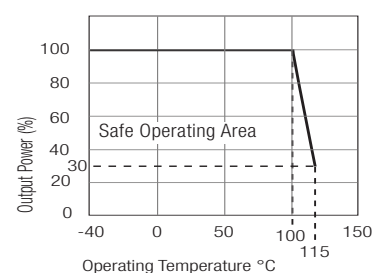

Refer to Application Notes

www.recom-power.com

Specifications (measured at $T_A = 25^\circ\text{C}$, nominal input voltage, full load and after warm-up)

Efficiency at Full Load		60%-70%
Minimum Load = 0%		Specifications valid for 10% minimum load only
Isolation Voltage	(tested for 1 second)	1000VDC
	(rated for 1 minute***)	500VAC / 60Hz
H-Suffix	(tested for 1 second)	3000VDC
	(rated for 1 minute***)	1500VAC / 60Hz
R0.25DA Output/ Output Isolation Voltage	(tested for 1 second)	1000VDC
Isolation Capacitance		75pF max.
Isolation Resistance	$V_{iso}=500V$	10 GΩ min.
Short Circuit Protection		1 Second
P-Suffix		Continuous
Operating Temperature Range (free air convection)		-40°C to +100°C (see Graph)
Storage Temperature Range		-50°C to +125°C
Reflow Temperature	ROHS compliant	245°C (30 sec), Peak 255°C (5 sec) max.
Vapour Phase Process	(for more details see Application Notes)	230°C (90 sec) max.
Relative Humidity		95% RH
Humidity Susceptibility Test		1000 hrs / 90% humidity / +85°C ambient
Package weight		1.0g (R0.25S), 1.2g (R0.25D(A))
Packing Quantity	R0.25S, R0.25S8	40 pcs per Tube
	R0.25S12, R0.25D, R0.25D10	33 pcs per tube
	R0.25D12, R0.25DA	33 pcs per tube
	All Types	500 pcs per Reel
MTBF (+25°C)	Detailed Information see Application Notes chapter "MTBF"	using MIL-HDBK 217F
(+85°C)		using MIL-HDBK 217F
Certifications		
Conducted / Radiated Emissions	EN55022	Level A
CB Test Report	Report: US/14402A/UL	IEC 60950-1:2001 1st Ed.
UL General Safety	Report: E358085	UL 60950-1 2nd Ed.
CUL General Safety		C22.2 No. 60950-1-03
EN Medical Safety	Report: MDD1205098-2 + RM1205098-2	IEC/EN 60601-1 3rd Edition
	Medical Report + ISO14971 Risk Assessment	
EN General Safety	Report: SPCLVD1211033-3	EN60950-1:2006 + A12:2011

***Any data referred to in this datasheet are of indicative nature and based on our practical experience only. For further details, please refer to our Application Notes.

Notes

Note 1: Maximum capacitive load is defined as the capacitive load that will allow start up in under 1 second without damage to the converter.

Typical Characteristics

Tolerance Envelope

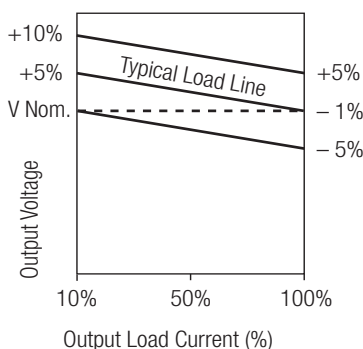

R0.25S**-xx05

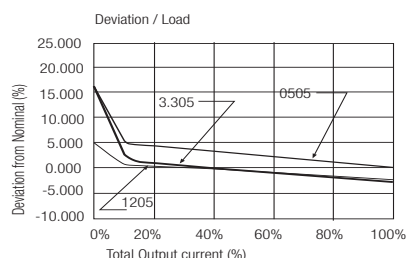
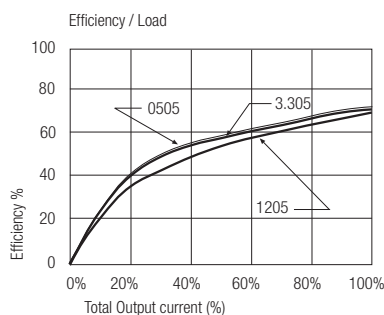

R0.25D**-xx05

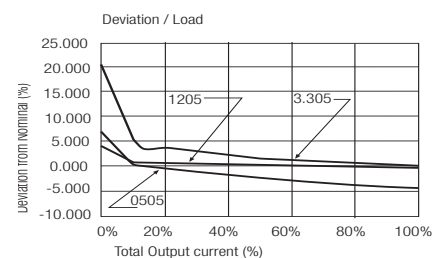
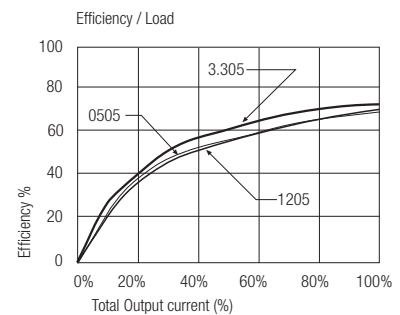

Package Style and Pinning (mm)

5 PIN Single SMD Package

Note: /H option is available in these pin packages

6 PIN Dual SMD Package

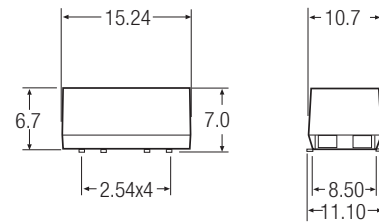
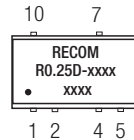
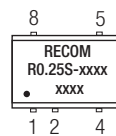
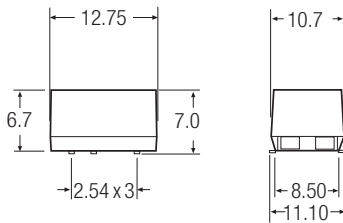

Recommended Footprint Details

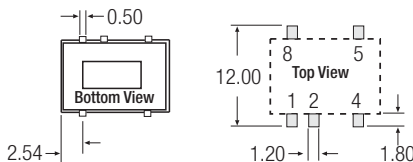

Pin Connections

Pin #	Single	Dual
1	-Vin	-Vin
2	+Vin	+Vin
4	-Vout	Com
5	+Vout	-Vout
7	No Pin	+Vout
8	NC	No Pin
10	No Pin	NC

NC = No Connection

XX.X ± 0.5 mm

XX.XX ± 0.25 mm

Recommended Footprint Details

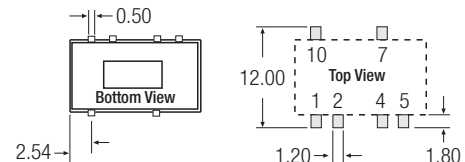

8 PIN Single SMD Package

Note: /H option is not available in these pin packages

10 PIN Dual SMD Package

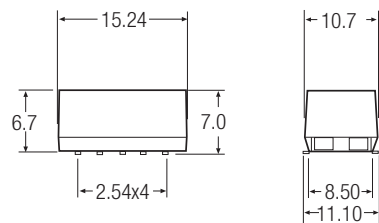
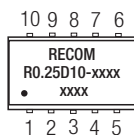
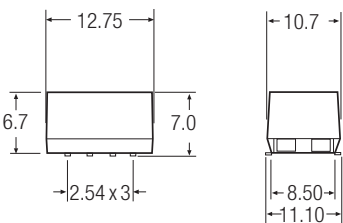

Recommended Footprint Details

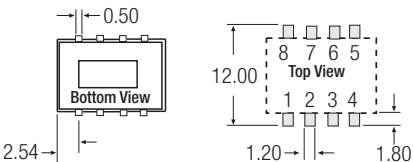

Pin Connections

Pin #	Single	Dual	Dual Independent
1	-Vin	-Vin	-Vin
2	+Vin	+Vin	+Vin
3	NC	NC	No Pin
4	-Vout	Com	-Vout1
5	+Vout	-Vout	+Vout1
6	NC	NC	-Vout2
7	NC	+Vout	+Vout2
8	NC	NC	No Pin
9	-	NC	No Pin
10	-	NC	NC

NC = No Connection

XX.X ± 0.5 mm

XX.XX ± 0.25 mm

Recommended Footprint Details (Dual)

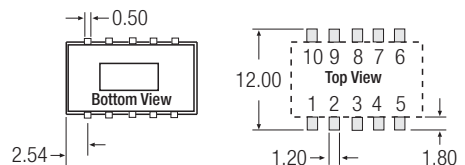

Recommended Footprint Details Dual Independent

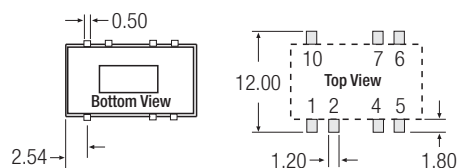

RO.25S** : ** without marking denotes 5 pins out of 8 fitted (includes /H option)
 ** with marking **8** denotes 8 pins out of 8 fitted (/H option not available)

e.g. RO.25S-0505, RO.25S-0505/H, RO.25S-0505/HP
 e.g. RO.25S8-0505, RO.25S8-0505/P

RO.25D** : ** without marking denotes 6 pins out of 10 fitted (includes /H option)
 ** with marking **10** denotes with 10 pins out of 10 fitted (/H option not available)

e.g. RO.25D-0505, RO.25D-0505/H, RO.25D-0505/HP
 e.g. RO.25D10-0505, RO.25D10-0505/P

Package Style and Pinning (mm)

12 PIN Single and Dual SMD Package

Note: /H option is available in this pin package

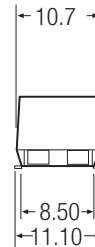
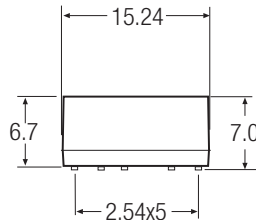
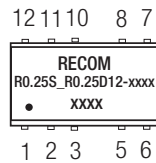

Pin Connections

Pin #	Single	Dual
1	-Vin	-Vin
2	+Vin	+Vin
3	NC	NC
5	-Vout	Com
6	NC	-Vout
7	NC	NC
8	+Vout	+Vout
10	NC	NC
11	NC	NC
12	NC	NC

NC = No Connection

XX.X ± 0.5 mm
XX.XX ± 0.25 mm

R0.25S** : ** with marking **12** denotes 10 pins out of 12 fitted (includes /H option)
e.g. R0.25S12-0505
R0.25S12-0505/H
R0.25S12-0505/HP

R0.25D** : ** with marking **12** denotes 10 pins out of 12 fitted (includes /H option)
e.g. R0.25D12-0505
R0.25D12-0505/H
R0.25D12-0505/HP

Recommended Footprint Details

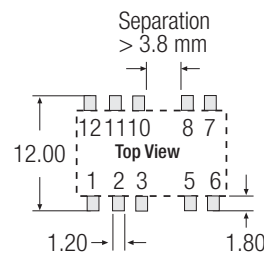
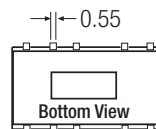

EMC Filtering - Suggestion for EN55022 Class B (Conducted and Emitted)

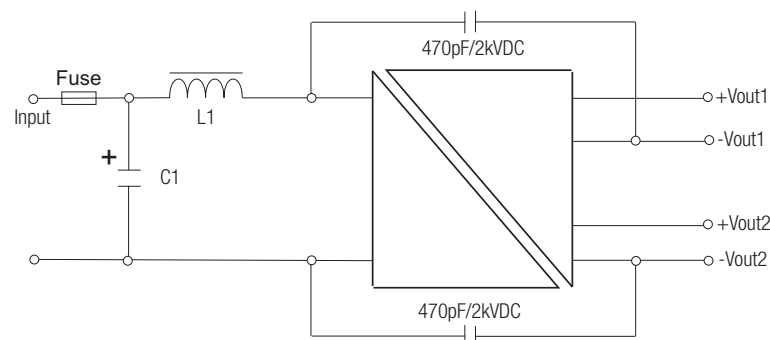
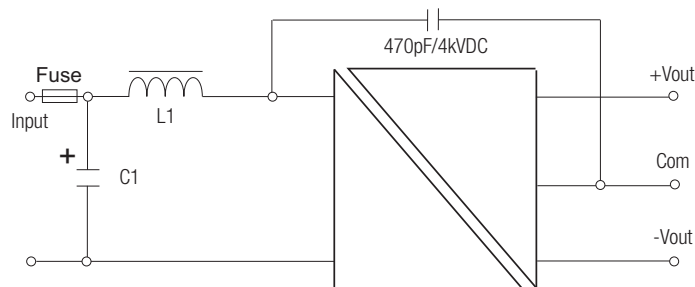
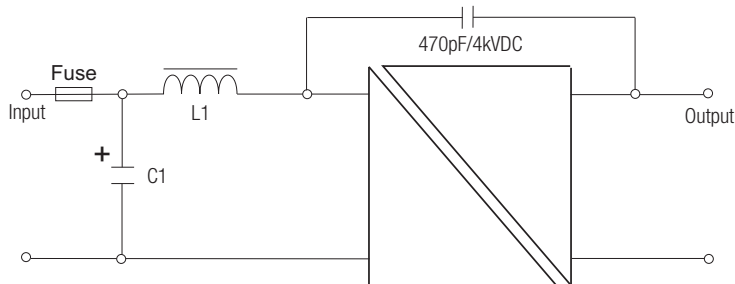

Standard and /H versions

C1	L1	Vin
2.2µF	3.3µH	3.3V
2.2µF	4.7µH	5V
1.0µF	22µH	12V
1.0µF	22µH	15V
470nF	47µH	24V

/P and /HP versions

C1	L1	Vin
2.2µF	3.3µH	3.3V
2.2µF	4.7µH	5V
1.0µF	22µH	12V
1.0µF	22µH	15V
470nF	47µH	24V

C1 = MLCC
L1 = SMD Inductor

Features

Unregulated Converter

- 1 : 1 Input Range
- 0.25W SMD Package
- Efficiency up to 77%
- 1kVDC and 2kVDC Isolation Option
- Operating Temperature from -40°C to +100°C
- EN/UL60950-1 Certified

Description

The R0.25S/E series DC/DC converter has been designed to offer exceptionally high efficiency, low quiescent current and an extended operating temperature range. Uses include battery powered supplies, high efficiency designs or high temperature applications.

Selection Guide

Part Number SMD	Input Voltage (VDC)	Output Voltage (VDC)	Output Current (mA)	Efficiency typ. (%)	Max Capacitive Load ^{(1)**}
R0.25S**-3.305/E*	3.3	5	50	75	1000µF
R0.25S**-0505/E*	5	5	50	77	1000µF
R0.25S**-1205/E*	12	5	50	74	1000µF

Other input and output voltage combinations available on request.

*add Suffix „H“ for 2kVDC Isolation, e.g. R0.25S-3.305/HE

*add Suffix „-R“ for tape & reel packaging, e.g. R0.25S-3.305/E -R

*add Suffix „P“ for Continuous Short Circuit Protection, e.g. R0.25S/PE

**without marking denotes 5 pins out of 8 fitted (includes „H“ option)

with marking 8 denotes 8 pins out of 8 fitted („H“ option not available), e.g. R0.25S8-3.305/E

Specifications (measured at $T_A = 25^\circ\text{C}$, nominal input voltage full load and after warm up)

Input Voltage Range		±10% max.
Voltage set accuracy	100% Load/nominal V_{in}	-2% typ. / ±5% max.
Line Regulation	Low Line to High Line @ max. Load	1,2% typ.
Load Regulation	(10% to 100% Load)	4% typ. / 10% max.
Ripple & Noise @ 20MHz BW		50mVp-p typ. / 100mVp-p max.
Efficiency	100% Load	70% min.
Operating Temperature		-40°C to + 100°C
Storage Temperature		-55°C to +125°C
Isolation Test Voltage	(tested for 1 second) (rated for 1 minute***)	1000VDC 500VAC / 60Hz
Isolation Test Voltage	H-Suffix (tested for 1 second) (rated for 1 minute***)	2000VDC 1000VAC / 60Hz
Isolation Capacitance		75PF max.
Isolation Resistance	Viso = 500V	10 GΩ min.
Humidity		95% max.
Operating Frequency	V_{in} (nom.)	20kHz min. / 70 kHz max.
Short-Circuit Protection		1 Second
MTBF	Using MIL-HDBK 217F (+100°C)	1352 x 10 ³ hours
	Using MIL-HDBK 217F (+25°C)	4494 x 10 ³ hours
<i>Detailed Information see Application Notes chapter „MTBF“</i>		
Weight		1.0g

Certification

UL General Safety	Report: E224736	UL60950-1
EN General Safety		EN60950-1

***Any data referred to in this datasheet are of indicative nature and based on our practical experience only. For further details, please refer to our Application Notes.

ECONOLINE

DC/DC-Converter

with 3 year Warranty

RECOM

0.25 Watt SMD Isolated Single Output

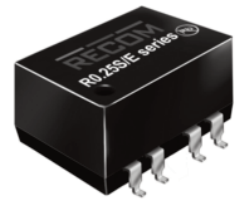

EN-60950-1 Certified
UL-60950-1 Certified

R0.25S/E

Derating-Graph (Ambient Temperature)

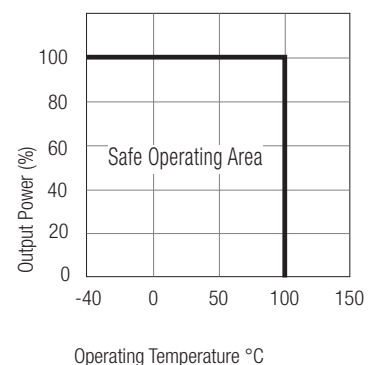

Refer to Application Notes

Typical Characteristics

Tolerance Envelope

R0.25S-xx05/E

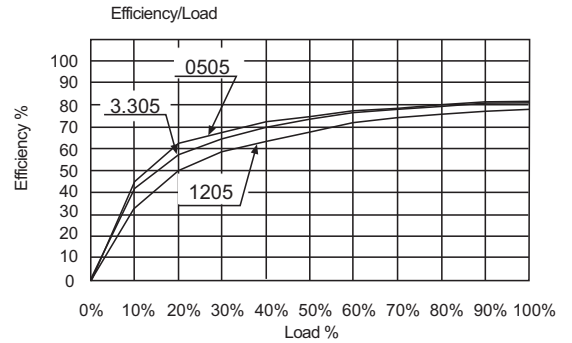
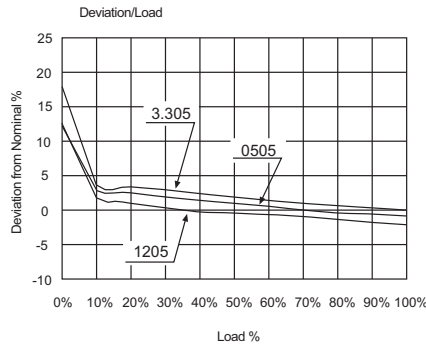
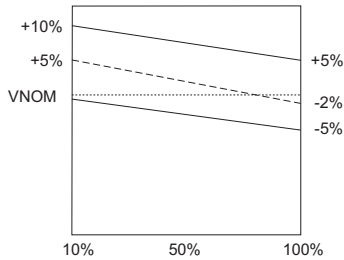

Notes

Note1: Maximum capacitive load is defined as the capacitive load that will allow start up in under 1second without damage to the converter.

Package Style and Pinning (mm)

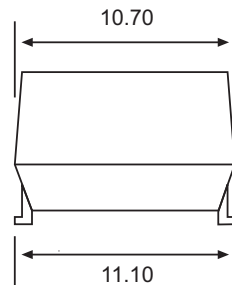
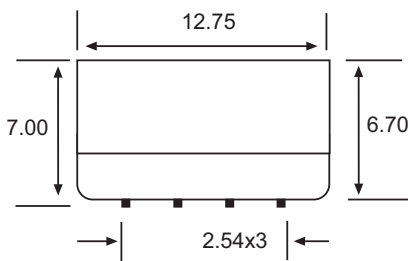

Pin Connections

Pin #	Function for 5 Pins	Function for 8 Pins
1	-Vin	-Vin
2	+Vin	+Vin
4	-Vout	-Vout
5	+Vout	+Vout
3, 6, 7	NA	NC
8	NC	NC

NC= No Connection

NA= No Available Electrical Connection

UNIT: mm

TOL.: ± 0.25 mm

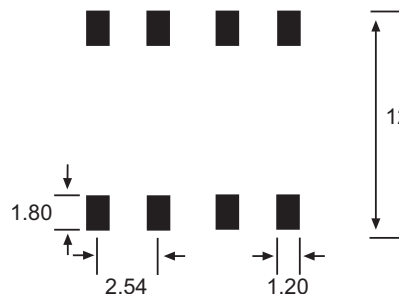
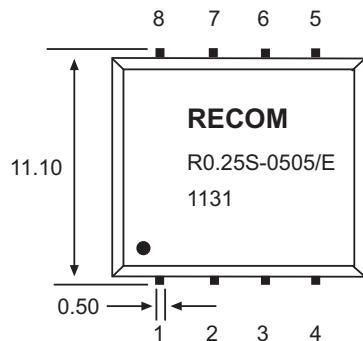

Footprint

R0.25S/E

Features

Unregulated Converter

- 1 : 1 Input Range
- 0.25W SIP7 Package
- Efficiency up to 82%
- 1kVDC and 2kVDC Isolation Option
- Operating Temperature from -40°C to +100°C

Description The RBL/E series DC/DC converter has been designed to offer exceptionally high efficiency, low quiescent current and an extended operating temperature range. Uses include battery powered supplies, high efficiency designs or high temperature applications.

Selection Guide

Part Number SMD	Input Voltage (VDC)	Output Voltage (VDC)	Output Current (mA)	Efficiency typ. (%)	Max Capacitive Load ^{(1)**}
RBL-3.305S/E*	3.3	5	50	80	1000µF
RBL-0505S/E*	5	5	50	82	1000µF
RBL-1205S/E*	12	5	50	78	1000µF

Other input and output voltage combinations available on request

*add Suffix „H“ for 2 kVDC Isolation, e.g. RBL-3.305/EH

Specifications (measured at T_A = 25°C, nominal input voltage, full load and after warm-up)

Input Voltage Range		±10% max.
Voltage set accuracy	100% Load/nominal Vin	-2% typ. / ±5% max.
Line Regulation		1.2% typ. / 1% of Vin typ.
Load Regulation	(10% to 100% Load)	4% typ. / 10% max.
Ripple & Noise @ 20MHz BW		35mVp-p typ. / 50mVp-p max.
Efficiency	100% Load	70% min.
Operating Temperature		-40°C to + 100°C
Storage Temperature		-55°C to +125°C
Isolation Voltage	(rested for 1 second)	1000VDC
	(rated for a minute**)	500VAC / 60Hz
Isolation Voltage	H-Suffix (tested for 1 second)	2000VDC
	H-Suffix (rated for a minute**)	1000VAC / 60Hz
Isolation Capacitance		75pF max.
Isolation Resistance		10 GΩ min.
Humidity		95% RH
Operating Frequency	Vin (nom.)	20kHz min. / 70 kHz max.
Short-Circuit Protection		1 Second
MTBF	Using MIL-HDBK 217F (+100°C)	1352 x 10 ³ hours
	Using MIL-HDBK 217F (+25°C)	4494 x 10 ³ hours
<i>Detailed Information see Application Notes chapter „MTBF“</i>		
Weight		2.2 g
Packing Quantity		25pcs per tube

**Any data referred to in this datasheet are of indicative nature and based on our practical experience only. For further details, please refer to our Application Notes.

Notes

Note1: Maximum capacitive load is defined as the capacitive load that will allow start up in under 1second without damage to the converter.

ECONOLINE

DC/DC-Converter

with 3 year Warranty

RECOM

0.25 Watt SIP7 Isolated Single Output



RBL/E

Derating-Graph (Ambient Temperature)

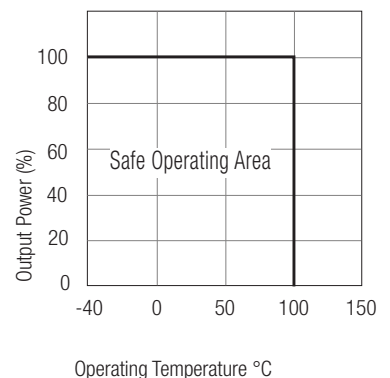

Refer to Application Notes

Typical Characteristics

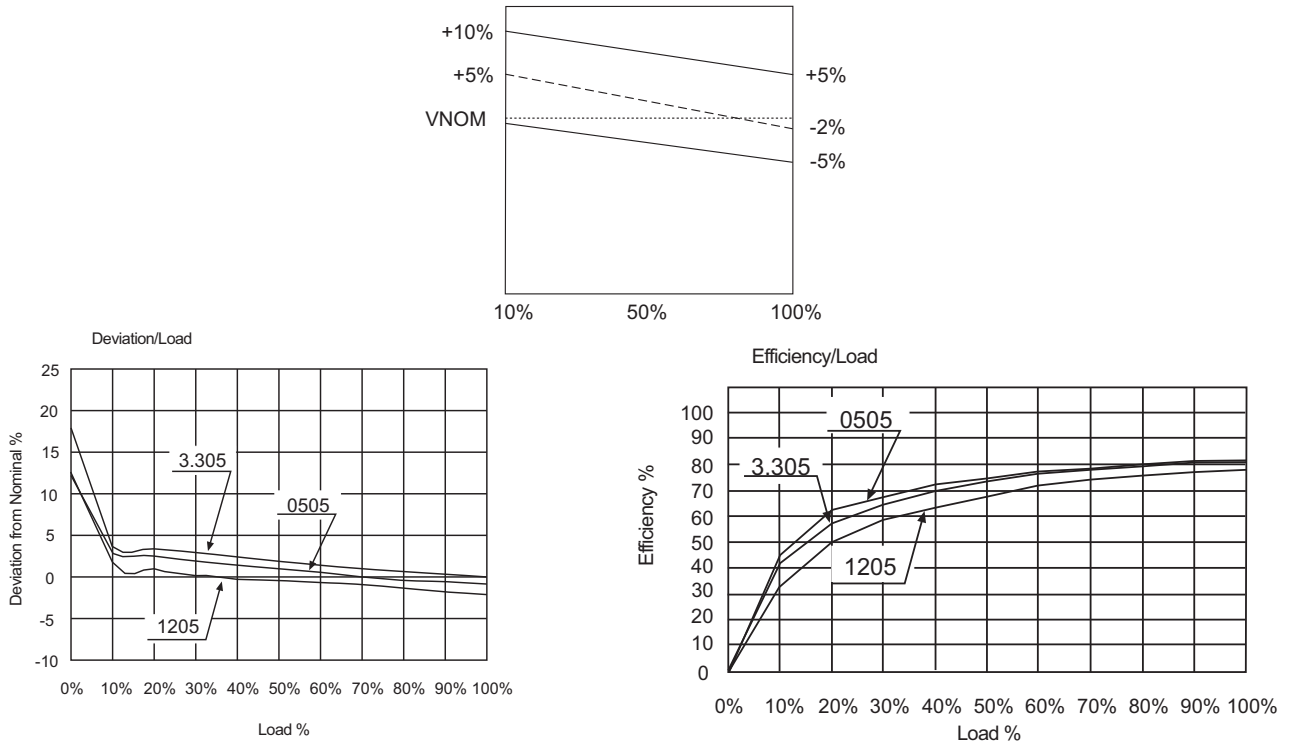

Package Style and Pinning (mm)

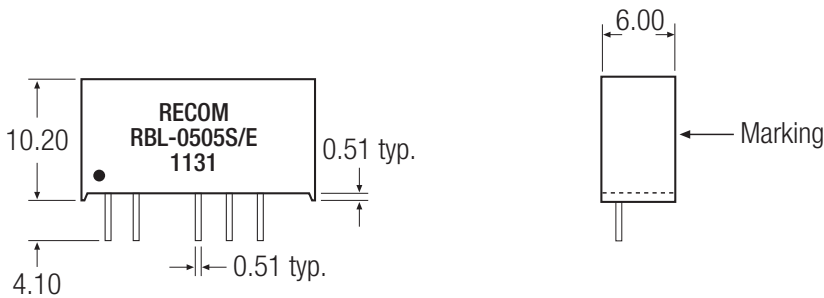

Pin Connections

Pin #	Function
1	+Vin
2	-Vin
4	NC
5	-Vout
6	+Vout

NC= No Connection
UNIT: mm
TOL.: ± 0.25 mm

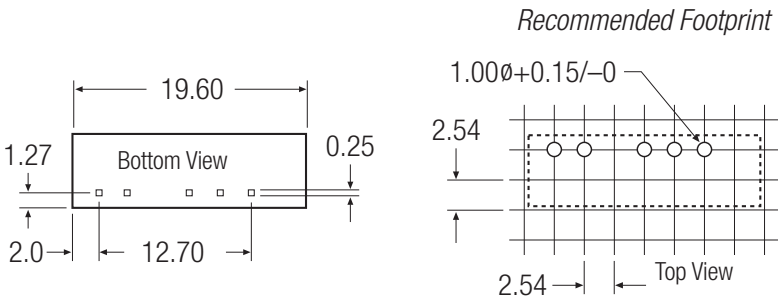

The product information and specifications are subject to change without prior notice. All products are designed for non-safety critical commercial and industrial applications. The Buyer agrees to implement safeguards that anticipate the consequences of any failures that might cause harm, loss of life and/or damage property.

Features

Unregulated Converter

- 1 : 1 Input Range
- 0.5W SMD Package
- Efficiency up to 80%
- Approved for Medical Applications
- 1kVDC and 3 kVDC Isolation Option
- Operating Temperature from -40°C to +100°C

Specifications (measured at $T_A = 25^\circ\text{C}$, nominal input voltage, full load and after warm-up)

Part Number SMD	Input Voltage (VDC)	Output Voltage (VDC)	Output Current (mA)	Efficiency typ. (%)	Max Capacitive Load ⁽¹⁾ **
R0.5S**-3.305*	3.3	5	100	80	1000µF
R0.5S**-3.312*	3.3	12	42	77	150µF
R0.5S**-3.315*	3.3	15	33	77	150µF
R0.5S**-0505*	5	5	100	72	1000µF
R0.5S**-0512*	5	12	42	77	150µF
R0.5S**-0515*	5	15	33	79	150µF
R0.5S**-1205*	12	5	100	74	1000µF
R0.5S**-1212*	12	12	42	75	150µF
R0.5S**-1215*	12	15	33	75	150µF
R0.5S**-2405*	24	5	100	75	1000µF
R0.5S**-2412*	24	12	42	77	150µF
R0.5S**-2415*	24	15	33	77	150µF
R0.5D**-3.305*	3.3	±5	±50	79	±470µF
R0.5D**-3.312*	3.3	±12	±21	76	±68µF
R0.5D**-3.315*	3.3	±15	±17	77	±68µF
R0.5D**-0505*	5	±5	±50	79	±470µF
R0.5D**-0512*	5	±12	±21	77	±68µF
R0.5D**-0515*	5	±15	±17	79	±68µF
R0.5D**1205*	12	±5	±50	76	±470µF
R0.5D**1212*	12	±12	±21	75	±68µF
R0.5D**1215*	12	±15	±17	75	±68µF
R0.5D**2405*	24	±5	±50	77	±470µF
R0.5D**2412*	24	±12	±21	75	±68µF
R0.5D**2415*	24	±15	±17	75	±68µF

*add Suffix "/H" for 3kVDC Isolation Voltage

*add Suffix "/P" for continuous short circuit protection

*add Suffix "-R" for tape & reel packing

For more details and dimensions of the tapes and reels see Application Notes

R0.5S**:

**without marking denotes 5 pins out of 8 fitted (includes „/H“ option)

**with marking 8 denotes 8 pins out of 8 fitted („/H“ option not available)

**with marking 12 denotes 10 pins out of 12 fitted (includes „/H“ option)

R0.5D**:

**without marking denotes 6 pins out of 10 fitted (includes „/H“ option)

**with marking 10 denotes 10 pins out of 10 fitted („/H“ option not available)

**with marking 12 denotes 10 pins out of 12 fitted (includes „/H“ option)

ECONOLINE

DC/DC-Converter

with 3 year Warranty

RECOM

0.5 Watt SMD Isolated Single or Dual Output



UL-60950-1 Certified

R0.5S_D

Derating-Graph (Ambient Temperature)

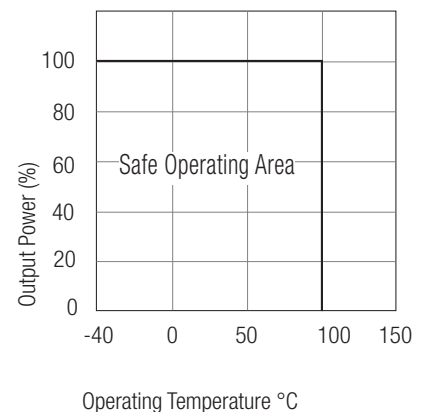

Refer to Application Notes

Specifications (measured at $T_A = 25^\circ\text{C}$, nominal input voltage, full load and after warm-up)

Input Voltage Range		$\pm 10\%$ max.
Voltage set accuracy	100% Load/nominal Vin	-1% typ. / $\pm 5\%$ max.
Line Regulation	Low Line to High Line @ max. Load	1.2% typ.
Load Regulation	5V output	6% typ. / 15% max.
(10% to 100% Load)	12/15V output	5% typ. / 10% max.
Ripple & Noise @ 20MHz BW		50 mVp-p typ. / 100mVp-p max.
Efficiency at Full Load		70% min.
Operating Temperature		-40°C to $+100^\circ\text{C}$
Storage Temperature		-55°C to $+125^\circ\text{C}$
Isolation Voltage	(tested for 1 second) (rated for 1 minute ^{***})	1000VDC 500VAC / 60Hz
Isolation Voltage	H-Suffix (tested for 1 second) H-Suffix (rated for 1 minute ^{***})	3000VDC 1500VAC / 60Hz
Isolation Capacitance		75pF max.
Isolation Resistance	Viso = 500V	10 G Ω min.
Humidity		95% max.
Operating Frequency	Vin (nom.)	20kHz min. / 50 kHz typ. / 90 kHz max.
Short-Circuit Protection		1 Second
MTBF	Using MIL-HDBK 217F ($+100^\circ\text{C}$)	1003×10^3 hours
Using MIL-HDBK 217F ($+25^\circ\text{C}$)	3962×10^3 hours	<i>Detailed Information see Application Notes chapter „MTBF“</i>
Weight	Single Types	1.0 g
	Dual Types	1.2 g
Certification		
UL General Safety	Report: E358085	UL 60950-1 2nd Ed.

^{***}Any data referred to in this datasheet are of indicative nature and based on our practical experience only. For further details, please refer to our Application Notes.

Notes

Note1: Maximum capacitive load is defined as the capacitive load that will allow start up in under 1second without damage to the converter.

Typical Characteristics

R0.5S-3.3xx

Tolerance Envelope

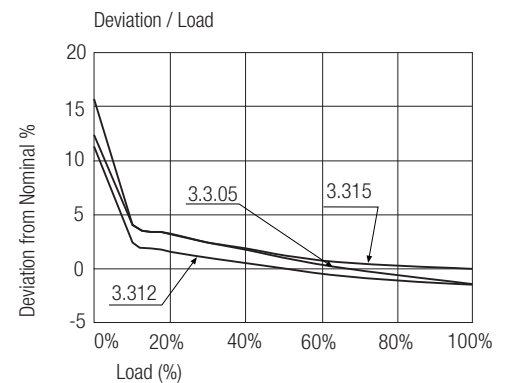
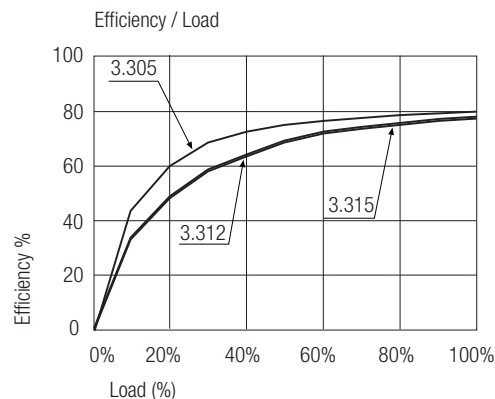
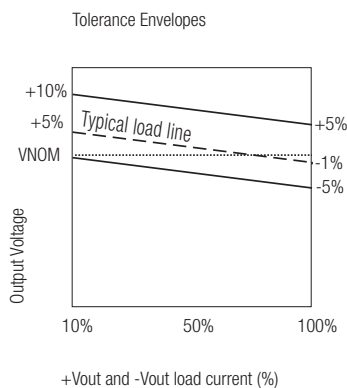

R0.5S-05xx

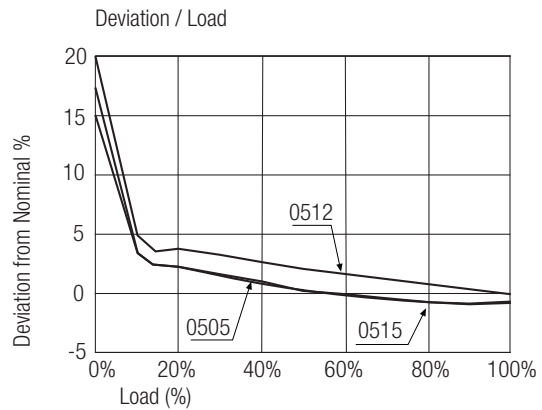
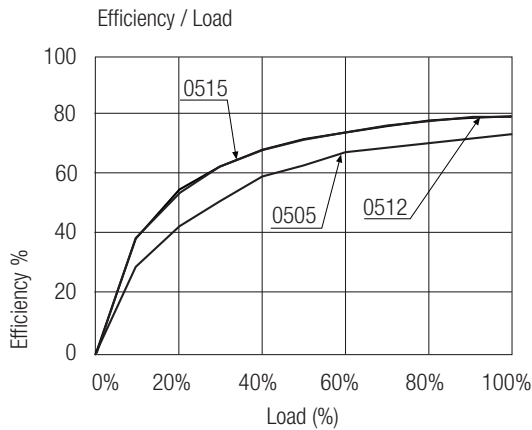

R0.5S-12xx

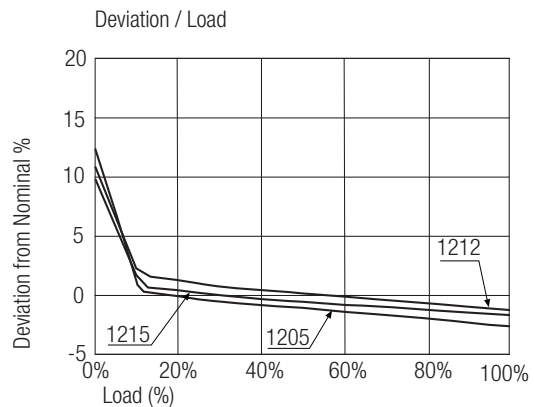
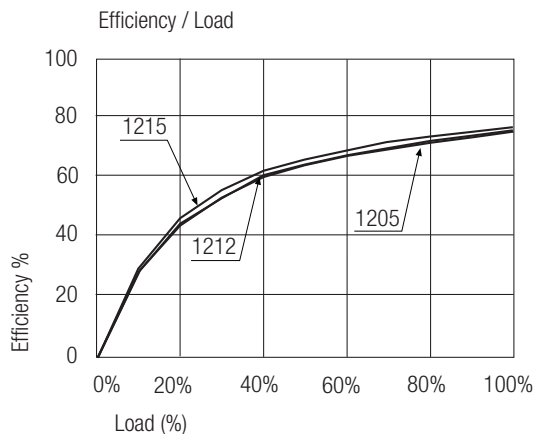

R0.5S-24xx

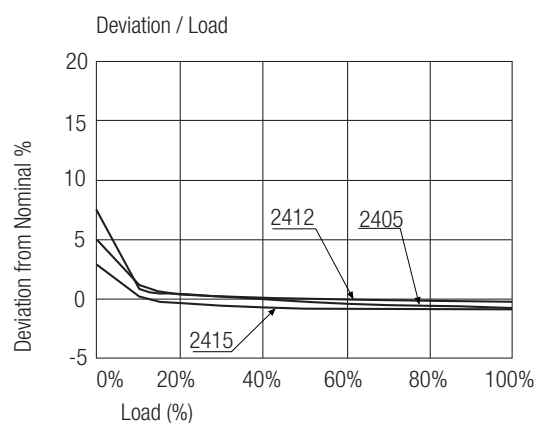
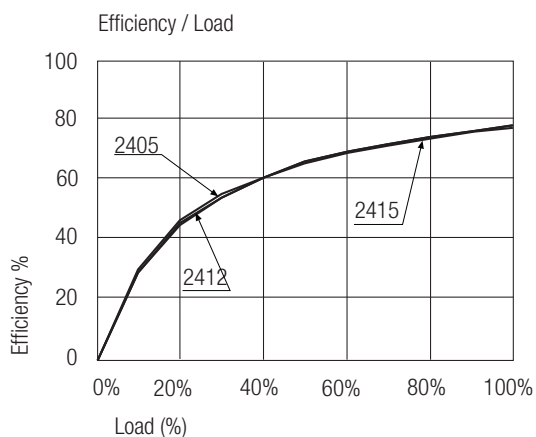

R0.5D-3.3xx

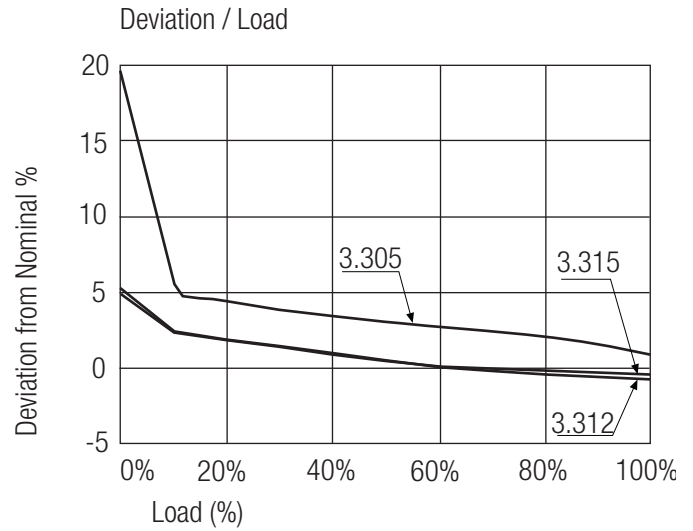
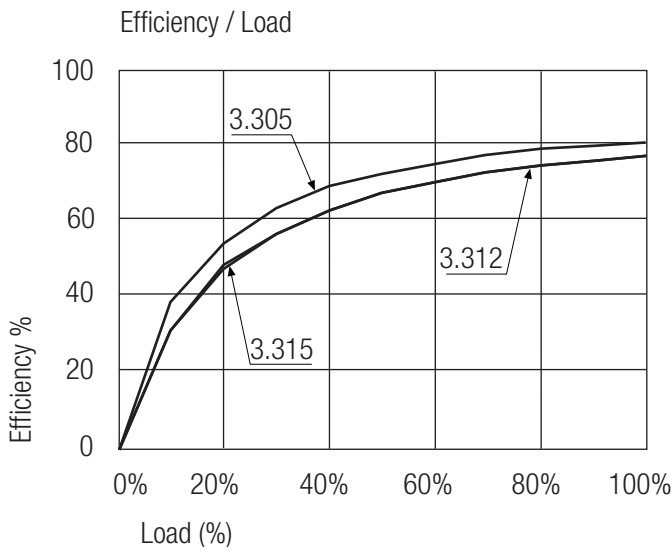

R0.5D-05xx

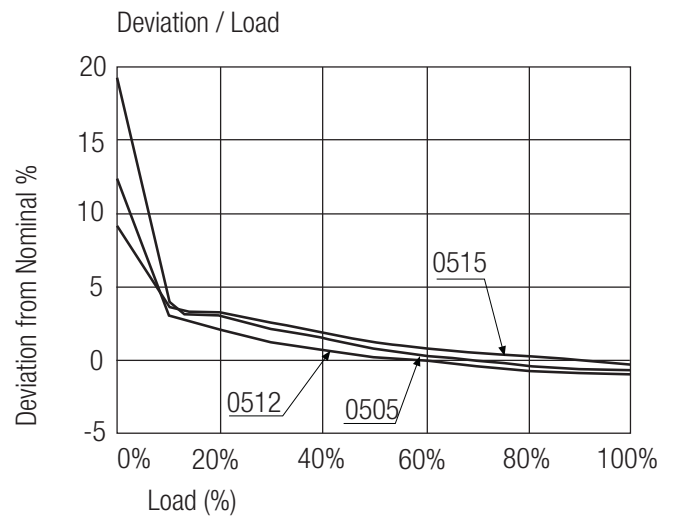
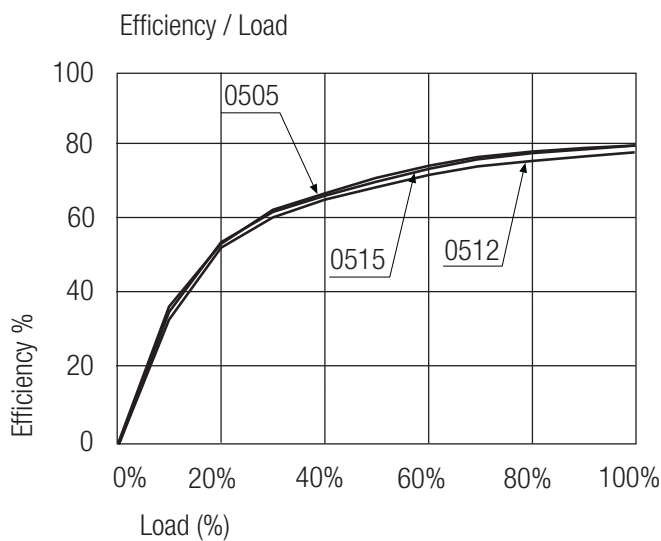

R0.5D-12xx

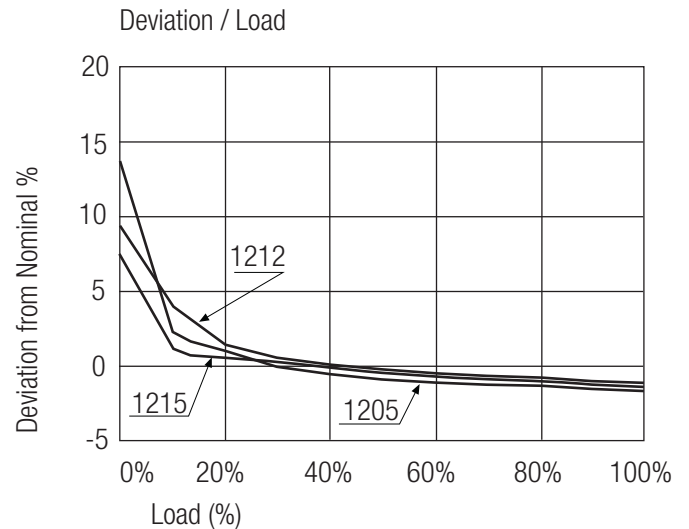
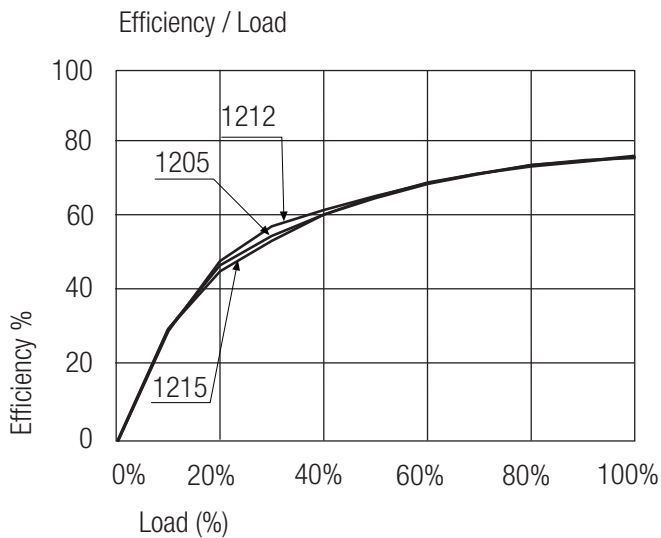

R0.5D-24xx

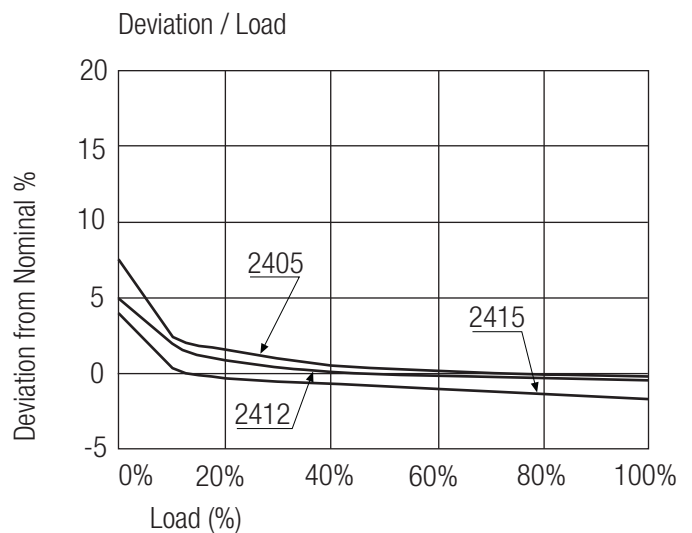
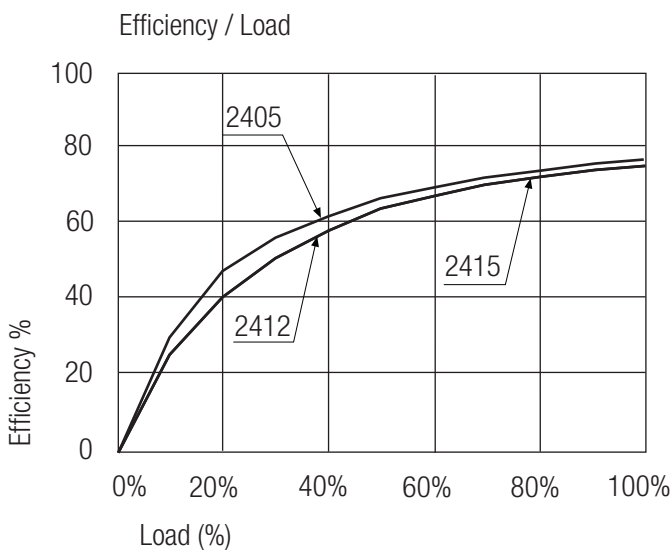

Package Style and Pinning (mm)

5 PINS Single SMD Package

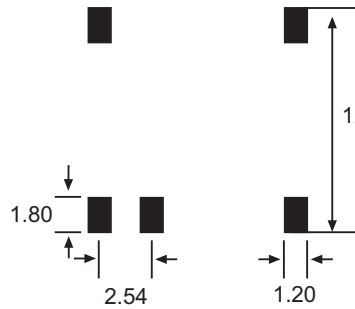
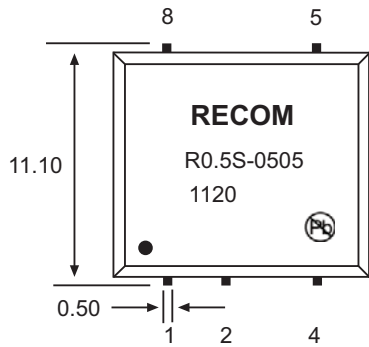
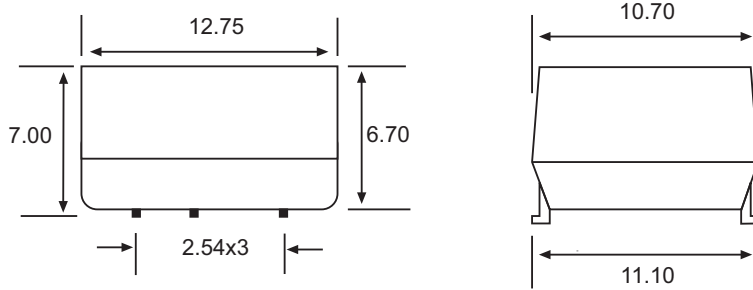

Footprint

Pin Connections

Pin #	Single	Dual
1	-Vin	-Vin
2	+Vin	+Vin
4	-Vout	Com.
5	+Vout	-Vout
7	No Pin	+Vout
8	NC	No Pin
10	No Pin	NC

NC= No Connection

UNIT: mm

TOL.: ± 0.25 mm

6 PINS Dual SMD Package

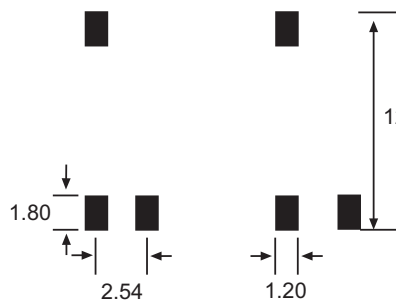
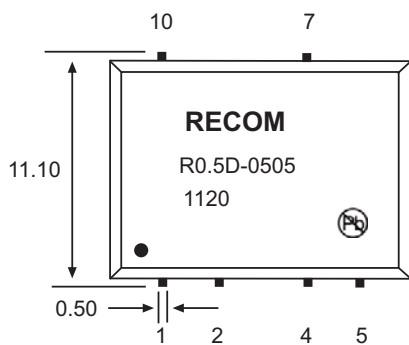
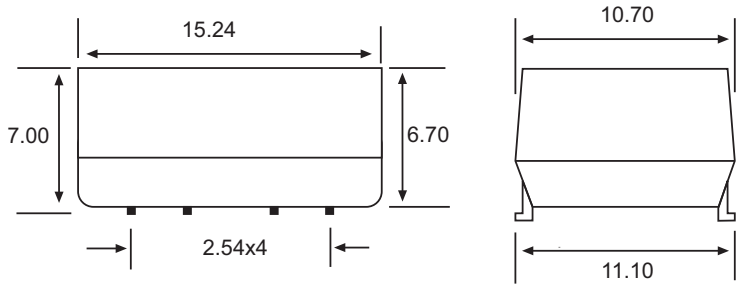

Footprint

Package Style and Pinning (mm)

8 PINS Single SMD Package

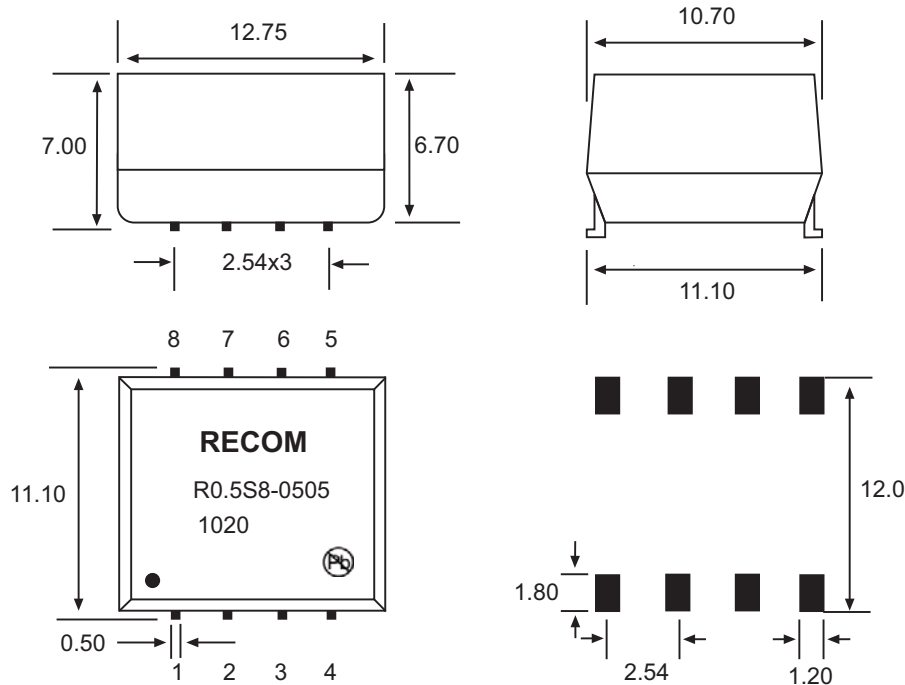

Footprint

Pin Connections

Pin #	Single	Dual
1	-Vin	-Vin
2	+Vin	+Vin
4	-Vout	Com.
5	+Vout	-Vout
7	NC	+Vout
3, 6, 8	NC	NC
9, 10	No Pin	NC

NC= No Connection

UNIT: mm

TOL.: ± 0.25 mm

10 PINS Dual SMD Package

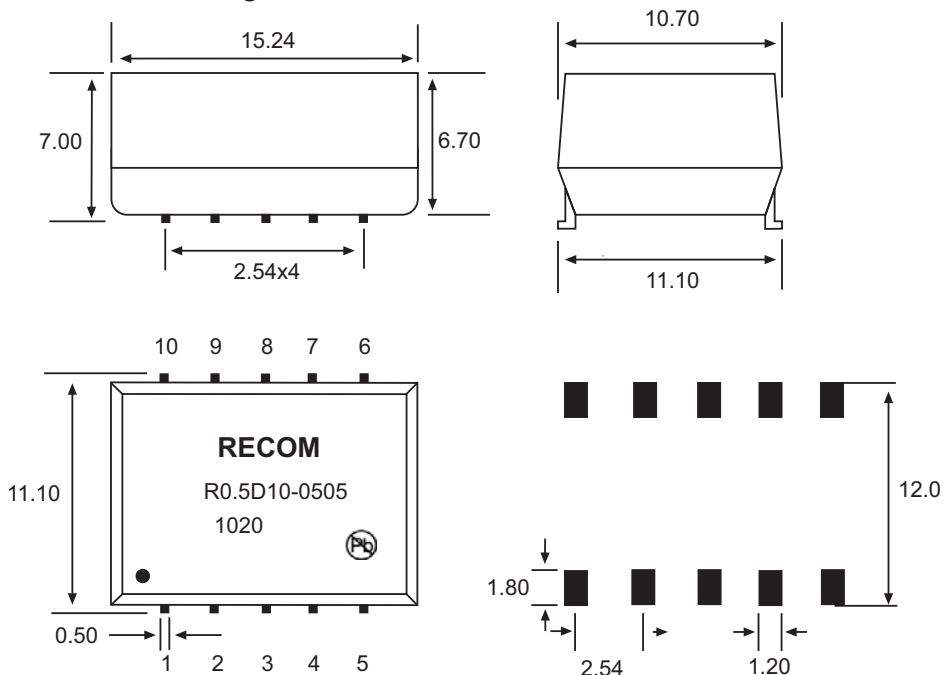

Footprint

ECONOLINE

DC/DC-Converter

R0.55_D Series

Package Style and Pinning (mm)

12 PINS Dual SMD Package

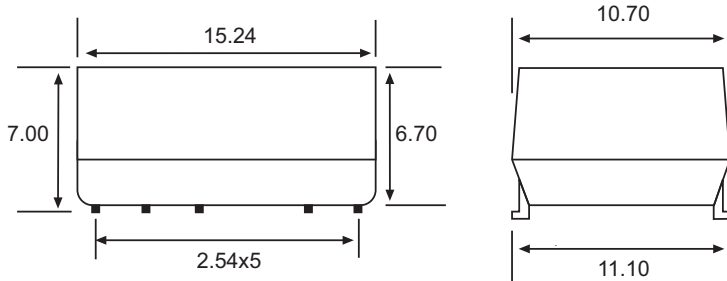

Pin Connections

Pin #	Function Single	Function Dual
1	-Vin	-Vin
2	+Vin	+Vin
5	-Vout	Com.
6	NC	-Vout
8	+Vout	+Vout
3,7,10,11,12	NC	NC

NC= No Connection

Unit: mm

TOL.: ± 0.25 mm

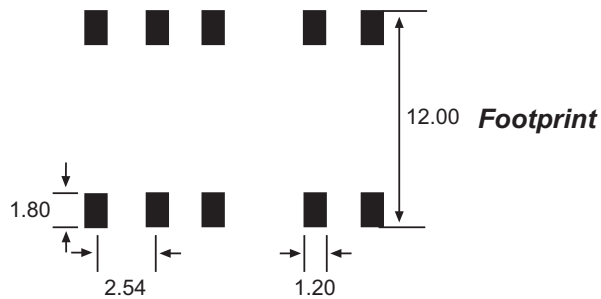
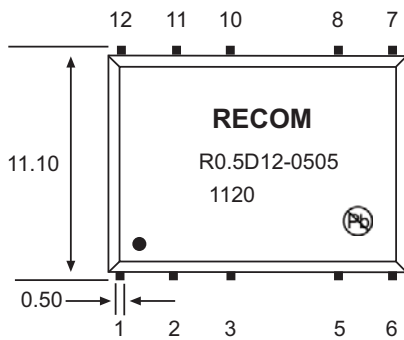

Features

Unregulated Converters

- Fully RoHS 6/6 Conform
- Full Power at 100°C Ambient Temperature
- 1kVDC or 3kVDC Isolation Options
- UL /CSA Certified, CB Report
- Suitable for Fully Automated Assembly (including Vapour Phase Soldering)
- Optional Continuous Short Circuit Protection
- Efficiency to 84%
- Built-In EN55022 Class A Filter

Description

The R1S and R1D converters are of the enclosed open frame type, i.e. they are not potted. The converters are typically used in general purpose and industrial low power isolation and voltage matching applications where an SMD converter is required.

The converter series feature an extended ambient temperature operating range of -40°C to +100°C without derating and optional continuous short circuit protection.

In addition to two isolation options and three different case formats, the converters are also available prepacked as tape and reel for use with automatic insertion machines.

Selection Guide

Part Number	SMD	Input Voltage (3kV)	Input Voltage (VDC)	Output Voltage (VDC)	Output Current (mA)	Efficiency (%)	Max Capacitive Load ⁽¹⁾
R1S**-xx3.3		(H)	3.3, 5, 12, 15, 24	3.3	303	75	2200µF
R1S**-xx05		(H)	3.3, 5, 12, 15, 24	5	200	72-78	1000µF
R1S**-xx09		(H)	3.3, 5, 12, 15, 24	9	111	74-78	1000µF
R1S**-xx12		(H)	3.3, 5, 12, 15, 24	12	84	75-80	470µF
R1S**-xx15		(H)	3.3, 5, 12, 15, 24	15	66	75-82	470µF
R1S**-xx24		(H)	3.3, 5, 12, 15, 24	24	42	74-84	220µF
R1D**-xx3.3		(H)	3.3, 5, 12, 15, 24	±3.3	±152	75	±1000µF
R1D**-xx05		(H)	3.3, 5, 12, 15, 24	±5	±100	72-78	±470µF
R1D**-xx09		(H)	3.3, 5, 12, 15, 24	±9	±56	74-78	±470µF
R1D**-xx12		(H)	3.3, 5, 12, 15, 24	±12	±42	75-80	±220µF
R1D**-xx15		(H)	3.3, 5, 12, 15, 24	±15	±33	75-82	±220µF
R1D**-xx24		(H)	3.3, 5, 12, 15, 24	±24	±21	74-84	±100µF

xx = Input Voltage (other input and output voltage combinations available on request)

* add Suffix "H" for 3kV Isolation, e.g. R1S-0505/H, R1D-0505/H, R1S12-0505/H, R1D12-0505/H

* add Suffix "P" for Continuous Short Circuit Protection, e.g. R1S8-0505/P, R1S-0505/HP, R1D12-0505/HP

* add suffix -R for tape & reel packing e.g. R1S-0505-R. For more details see Application Notes.

Case and Pinning Options (note restrictions on /H option)

R1S** : ** without marking denotes 5 pins out of 8 fitted (includes /H option)
 ** with marking **8** denotes 8 pins out of 8 fitted (/H option not available)
 ** with marking **12** denotes 10 pins out of 12 fitted (includes /H option)

R1D** : ** without marking denotes 6 pins out of 10 fitted (includes /H option)
 ** with marking **10** denotes with 10 pins out of 10 fitted (/H option not available)
 ** with marking **12** denotes 10 pins out of 12 fitted (includes /H option)

Specifications (measured at T_A = 25°C, nominal input voltage, full load and after warm-up)

Input Voltage Range		±10%
Output Voltage Accuracy		±2% typ., ±5% max.
Line Voltage Regulation	All Variants	1.2%/1% of Vin typ.
Load Voltage Regulation (10% to 100% full load)	3.3V output types	15% typ., 20% max.
	5V output type	12% typ., 15% max.
	9V output type	7% typ., 10% max.
	12V, 15V, 24V output types	6% typ., 10% max.
Output Ripple and Noise (20MHz BW limited)		50mVp-p typ., 100mVp-p max.
Operating Frequency		20kHz min. / 60kHz typ. / 100kHz max.

continued on next page

ECONOLINE

DC/DC-Converter

with 3 year Warranty

RECOM

1 Watt SMD Single & Dual Output



UL-60950-1 Certified
60950-1 Certified
EN-60601-1 Certified*
 (* /H suffix)

EN-

R1S_R1D

Derating-Graph (Ambient Temperature)

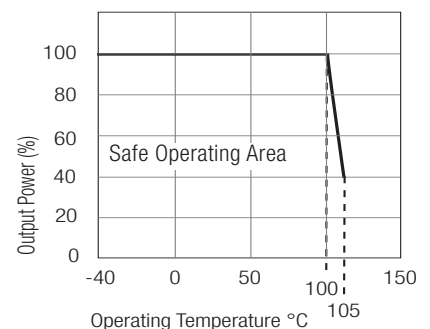

Refer to Application Notes

Specifications (measured at $T_A = 25^\circ\text{C}$, nominal input voltage, full load and after warm-up)

Efficiency at Full Load	See Selection Guide		
Minimum Load = 0%	Specifications valid for 10% minimum load only.		
Isolation Voltage	(tested for 1 second) (rated for 1 minute***)	1000VDC 500VAC / 60Hz	
Isolation Voltage	H-Suffix (tested for 1 second) H-Suffix (rated for 1 minute***)	3000VDC 1500VAC / 60Hz	
Isolation Capacitance	R1S, R1S8, R1D, R1D10 R1S12, R1D12	15pF min. / 70pF max. 10pF min. / 75pF max.	
Isolation Resistance	10 $\text{G}\Omega$ min.		
Short Circuit Protection	1 Second		
P-Suffix	Continuous		
Operating Temperature Range (free air convection)	-40°C to +100°C (see Graph)		
Storage Temperature Range	-55°C to +125°C		
Reflow Temperature	ROHS compliant	245°C (30 sec), Peak 255°C (5 sec) max.	
Vapour Phase Process	(for more details see Application Notes)	230°C (90 sec) max.	
Relative Humidity	95% RH		
Humidity Susceptibility Test	1000 hrs / 90% humidity / +85°C ambient		
Package weight	R1S R1S8 R1S12, R1D, R1D10, R1D12	1.0g 1.1g 1.2g	
Packing Quantity	R1S, R1S8 R1S12, R1D, R1D10, R1D12 All Types	40 pcs per Tube 33 pcs per tube 500 pcs per Reel	
MTBF (+25°C) (+85°C)	} Detailed Information see Application Notes chapter "MTBF"	using MIL-HDBK 217F	4275 x 10 ³ hours
		using MIL-HDBK 217F	1365 x 10 ³ hours
Certifications			
CB Test Report	Report: US/14402A/UL	IEC 60950-1:2001 1st Ed.	
UL General Safety	Report: E358085	UL 60950-1 2nd Ed.	
CUL General Safety		C22.2 No. 60950-1-03	
EN Medical Safety	Report: MDD1205098-2 + RM1205098-2 Medical Report + ISO14971 Risk Assessment	IEC/EN 60601-1 3rd Edition	
EN General Safety	Report: SPCLVD1211033-3	EN60950-1: 2006 + A12:2011	
Conducted / Radiated Emissions	EN55022	Level A	

***Any data referred to in this datasheet are of indicative nature and based on our practical experience only. For further details, please refer to our Application Notes.

Notes

Note 1: Maximum capacitive load is defined as the capacitive load that will allow start up in under 1 second without damage to the converter.

Typical Characteristics

Tolerance Envelope

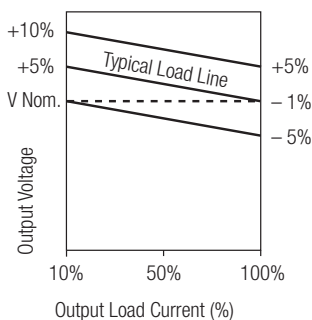

R1S**-xx05

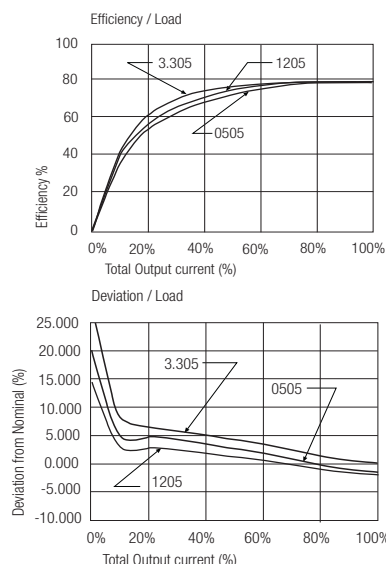

R1D**-xx05

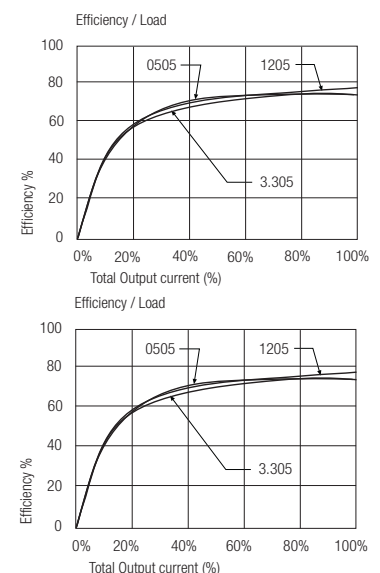

Package Style and Pinning (mm)

5 PIN Single SMD Package

Note: /H option is available in these pin packages

6 PIN Dual SMD Package

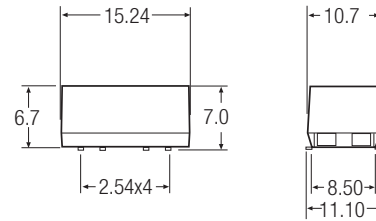
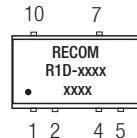
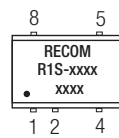
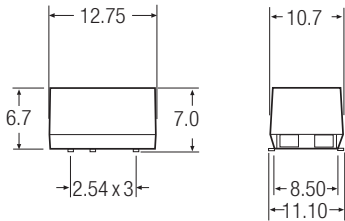

Recommended Footprint Details

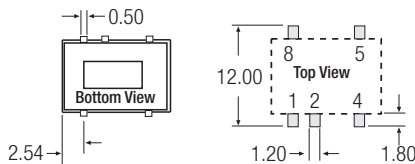

Pin Connections

Pin #	Single	Dual
1	-Vin	-Vin
2	+Vin	+Vin
4	-Vout	Com
5	+Vout	-Vout
7	No Pin	+Vout
8	NC	No Pin
10	No Pin	NC

NC = No Connection

XX.X ± 0.5 mm

XX.XX ± 0.25 mm

Recommended Footprint Details

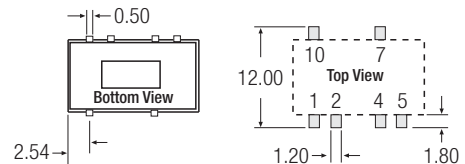

8 PIN Single SMD Package

Note: /H option is not available in these pin packages

10 PIN Dual SMD Package

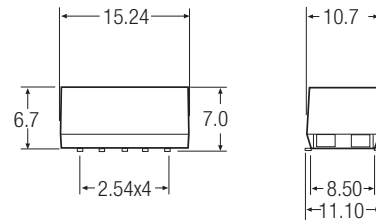
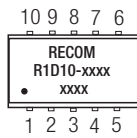
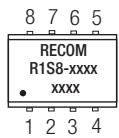
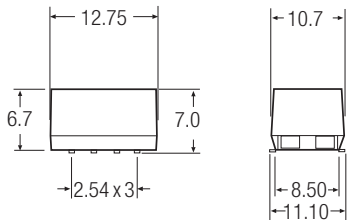

Recommended Footprint Details

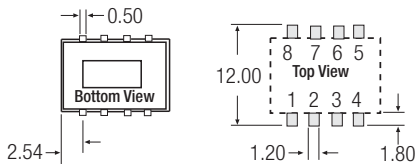

Pin Connections

Pin #	Single	Dual
1	-Vin	-Vin
2	+Vin	+Vin
3	NC	NC
4	-Vout	Com
5	+Vout	-Vout
6	NC	NC
7	NC	+Vout
8	NC	NC
9	-	NC
10	-	NC

NC = No Connection

XX.X ± 0.5 mm

XX.XX ± 0.25 mm

Recommended Footprint Details

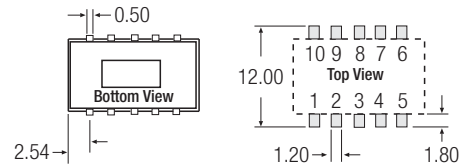

R1S** : ** without marking denotes 5 pins out of 8 fitted (includes /H option)
 ** with marking **8** denotes 8 pins out of 8 fitted (/H option not available)

e.g. R1S-0505, R1S-0505/H, R1S-0505/HP
 e.g. R1S8-0505, R1S8-0505/P

R1D** : ** without marking denotes 6 pins out of 10 fitted (includes /H option)
 ** with marking **10** denotes with 10 pins out of 10 fitted (/H option not available)

e.g. R1D-0505, R1D-0505/H, R1D-0505/HP
 e.g. R1D10-0505, R1D10-0505/P

Package Style and Pinning (mm)

12 PIN Single and Dual SMD Package

Note: /H option is available in this pin package

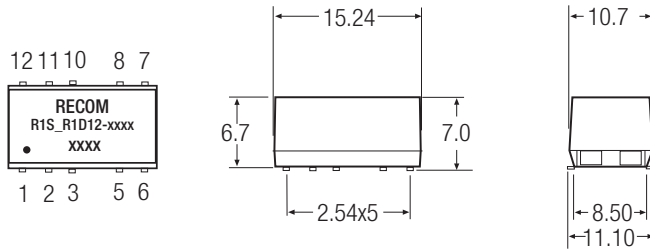

Pin Connections

Pin #	Single	Dual
1	-Vin	-Vin
2	+Vin	+Vin
3	NC	NC
5	-Vout	Com
6	NC	-Vout
7	NC	NC
8	+Vout	+Vout
10	NC	NC
11	NC	NC
12	NC	NC

NC = No Connection

XX.X ± 0.5 mm

XX.XX ± 0.25 mm

Recommended Footprint Details

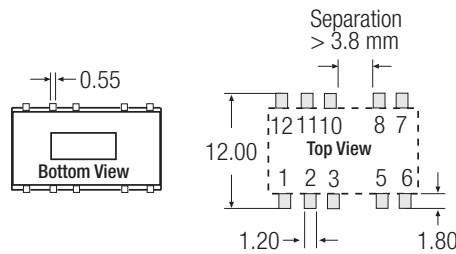

R1S** : ** with marking 12 denotes 10 pins out of 12 fitted (includes /H option)

R1D** : ** with marking 12 denotes 10 pins out of 12 fitted (includes /H option)

e.g. R1S12-0505, R1S12-0505/H, R1S12-0505/HP

e.g. R1D12-0505, R1D12-0505/H, R1D12-0505/HP

EMC Filtering - Suggestion for EN55022 Class B (Conducted and Emitted)

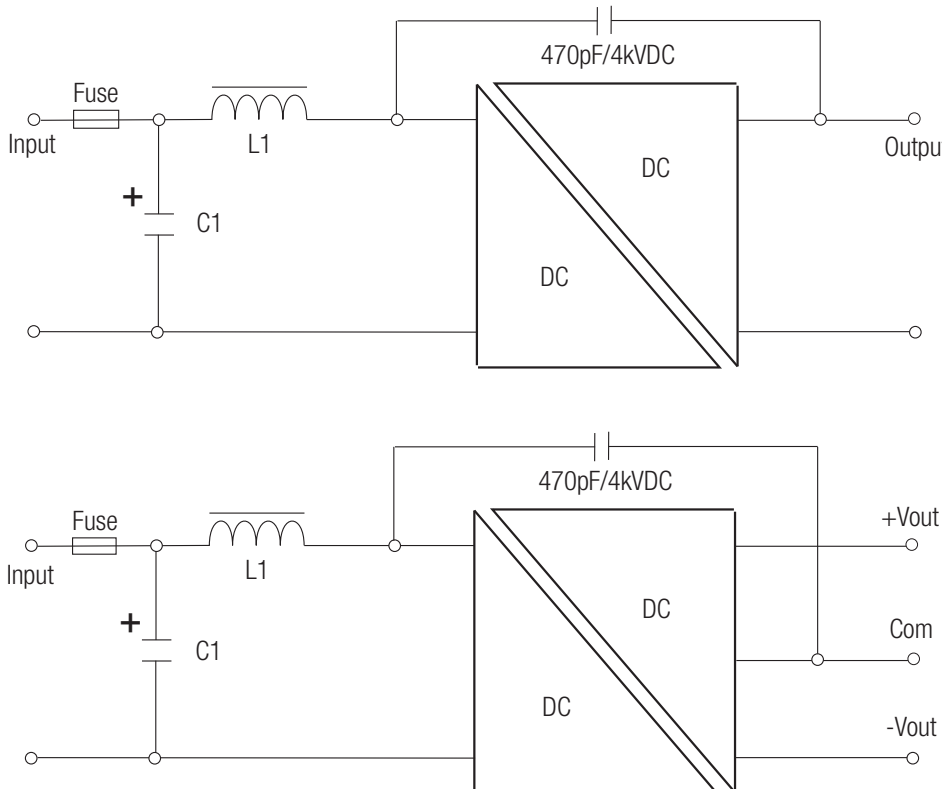

Standard and /H versions

C1	L1	Vin
4.7µF	3.3µH	3.3V
2.2µF	4.7µH	5V
2.2µF	10µH	12V
2.2µF	22µH	15V
4.7µF	22µH	24V

/P and /HP versions

C1	L1	Vin
4.7µF	10µH	3.3V
10µF	10µH	5V
4.7µF	22µH	12V
4.7µF	22µH	15V
10µF	47µH	24V

C1 = MLCC

L1 = SMD Inductor

Features

Unregulated Converters

- Efficiency 82% Full Load
- 1:1 Input Range
- 1kVDC and 2kVDC Isolation Option
- EN pending & UL Certified
- -40°C to +100°C Operating Temperature Range
- 1W SMD Package

Description

The R1S/E series is an unregulated DC/DC converter in fully encapsulated SMD package style. This series has been designed to offer exceptionally high efficiency at low loads and an extended operating temperature range. Uses include battery powered supplies, green energy applications and general isolating/converting DC power where board space and high efficiency is a premium.

Selection Guide

Part Number SMD	Isolation Voltage (kVDC)	Input Voltage (VDC)	Output Voltage (VDC)	Output Current (mA)	Efficiency (typ.)	Capacitive Load (max.) ⁽¹⁾
R1S**-3.305/E*	1	3.3	5	200	81%	2200µF
R1S**-0505/E*	1	5	5	200	81%	2200µF
R1S**-1205/E*	1	12	5	200	82%	2200µF
R1S**-2405/E*	1	24	5	200	80%	2200µF

** without marking denotes 5 pins out of 8 fitted (includes /H option) - e.g. R1S-3.305/EH

** with marking "8" denotes 8 pins out of 8 fitted (/H option not available) - e.g. R1S8-3.305/E

* add Suffix "/H" for 2kVDC Isolation Voltage - e.g. R1S-3.305/EH

* add Suffix "/P" for Continuous Short Protection - e.g. R1S-3.305/EHP, R1S8-3.305/EP

* add Suffix "-R" for tape & reel packing - e.g. R1S-3.305/EHP-R, R1S8-3.305/E-R

Specifications (measured at T_A = 25°C, nominal input voltage, full load and after warm-up)

Input Voltage Range		±10%
Output Voltage Accuracy	3.3V, 5V, 12V, 24V	±5% max.
Line Voltage Regulation (low line to high line at full load)	3.3V, 5V, 12V, 24V	1.2% max.
Load Voltage Regulation	Load Deviation 10% to 100%	15% max.
Output Ripple and Noise (20MHz BW)		50mVp-p typ., 100mVp-p max.
Operating Frequency (Vin=nominal input)		20kHz min. / 90kHz max.
Efficiency		see Selection Guide
Minimum Load = 0%	Specifications valid for 10% minimum load only	
Isolation Voltage	(tested for 1 second)	1000 VDC
	(rated for 1 minute***)	500VAC / 60Hz
H-Suffix	(tested for 1 second)	2000 VDC
	(rated for 1 minute***)	1000VAC / 60Hz
Isolation Capacitance		75pF max.
Isolation Resistance	(Viso=500V)	10GΩ min.
Short-Circuit Protection		1 second
Operating Temperature Range		-40°C to +100°C
Storage Temperature		-55°C to +125°C
Reflow Temperature	RoHS compliant	245°C (30 sec.), Peak 255°C (5sec.) max.
Vapour Phase Process	(for more details see Application Notes)	230°C (90 sec.) max.
Relative Humidity		95% RH
Package Weight	(R1S8/xx05/E = 1.1g)	1.0g
Packing Quantity		40 pcs per Tube
		500 pcs per Reel
MTBF (+25°C)	using MIL-HDBK 217F	3459 x 10 ³ hours
MTBF (+100°C)	using MIL-HDBK 217F	756 x 10 ³ hours

Note: Detailed Information see Application Notes chapter "MTBF"

***Any data referred to in this datasheet are of indicative nature and based on our practical experience only. For further details, please refer to our Application Notes.

ECONOLINE

DC/DC-Converter

with 3 year Warranty

RECOM

1 Watt SMD Single Output

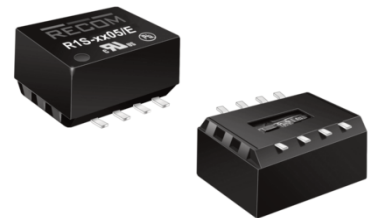

EN-60950-1 (pending)
UL-60950-1 Certified

R1S/E

Derating-Graph (Ambient Temperature)

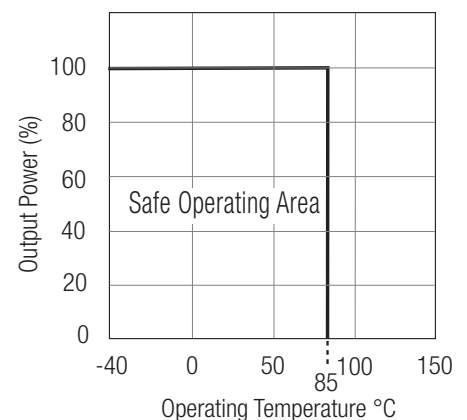

Refer to Application Notes

Typical Characteristics

Tolerance Envelope

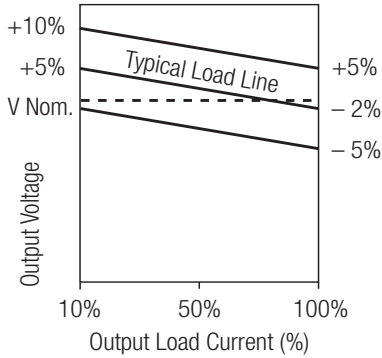

R1S-xx05/E

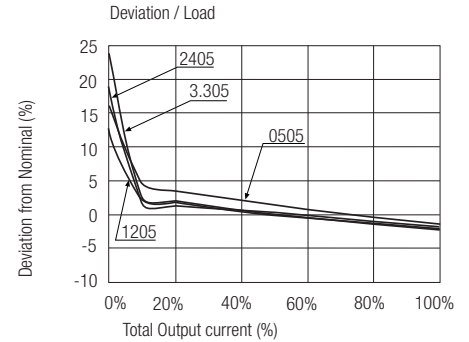
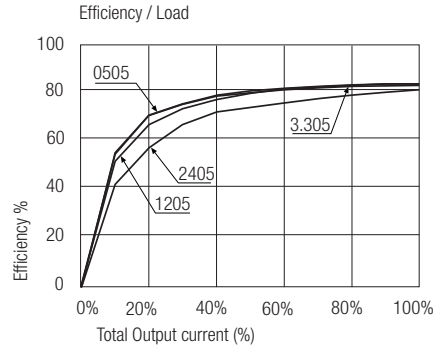

Notes

Note 1: Maximum capacitive load is defined as the capacitive load that will allow start up in under 1 second without damage to the converter.

Package Style and Pinning

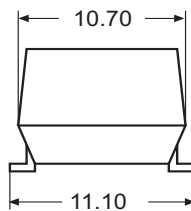
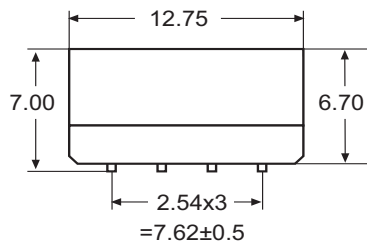

8 Pins:

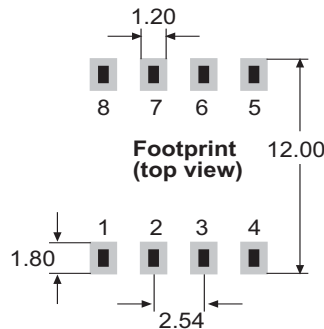
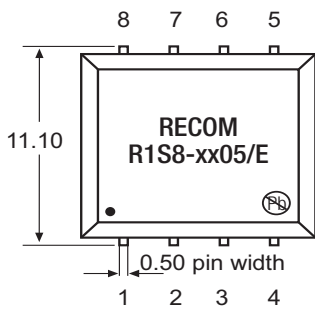

5 Pins:

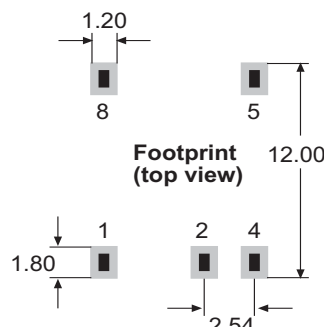
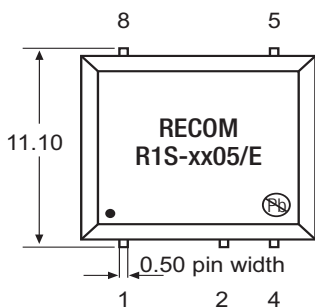

Pin Connections	Function	Function
Pin #	5 Pins	8 Pins
1	-Vin	-Vin
2	+Vin	+Vin
4	-Vout	-Vout
5	+Vout	+Vout
3,6,7	NA	NC
8	NC	NC

NC = No Internal Connection
NA = No Available Connection

Unit: mm
Tolerance: ± 0.25 mm

The product information and specifications are subject to change without prior notice. All products are designed for non-safety critical commercial and industrial applications. The Buyer agrees to implement safeguards that anticipate the consequences of any failures that might cause harm, loss of life and/or damage property.

Features

Unregulated Converter

- 1:1 Input Range
- SMD Package
- Efficiency up to 75%
- 1kVDC Isolation
- Operating Temperature from -40°C to +85°C
- UL Certified

Selection Guide

Part Number SMD	Input Voltage (VDC)	Output Voltage (VDC)	Output Current (mA)	Efficiency typ. (%)
R1SE**-0505*	5	5	200	75

*add suffix -R for tape & reel packing

Case and Pinning Options

** without marking denotes 5 pins out of 8 fitted
with marking 8 denotes 8 pins out of 8 fitted

Specifications (measured at $T_A = 25^\circ\text{C}$, nominal input voltage full load and after warm up)

Input Voltage Range		$\pm 10\%$ max.
Voltage set accuracy	100% Load/nominal V_{in}	-2% typ. / $\pm 5\%$ max.
Line Regulation	Low Line to High Line @ max. Load	1.2% typ.
Load Regulation	(10% to 100% Load)	10% typ. / 15% max.
Ripple & Noise @ 20MHz BW		68mVp-p typ. / 100mVp-p max.
Efficiency	100% Load	70% min. / 75% max.
Operating Temperature		-40°C to + 85°C
Storage Temperature		-55°C to +125°C
Isolation Test Voltage	(tested for 1 second) (rated for 1 minute***)	1000VDC 500VAC / 60Hz
Isolation Capacitance		75pF max.
Isolation Resistance	Viso = 500V	10 G Ω min.
Humidity		95% max.
Operating Frequency	V_{in} (nom.)	20kHz min. / 70 kHz max.
Short-Circuit Protection		1 Second
Weight		1.0g
MTBF	Using MIL-HDBK 217F (+90°C) Using MIL-HDBK 217F (+25°C)	172 x 10 ³ hours 1022 x 10 ³ hours

Detailed Information see Application Notes chapter „MTBF“

Certification

UL General Safety Report: E358085-A2 UL60950-1

***Any data referred to in this datasheet are of indicative nature and based on our practical experience only. For further details, please refer to our Application Notes.

Tolerance Envelopes

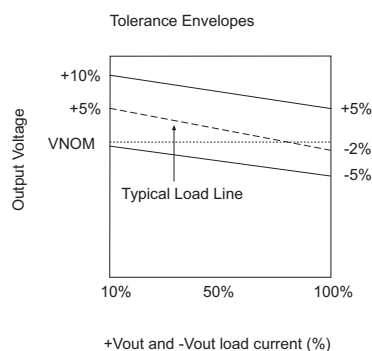

ECONOLINE

DC/DC-Converter

with 3 year Warranty

RECOM

1 Watt SMD Isolated Single Output



E358085

UL-60950-1 Certified

R1SE

Derating-Graph (Ambient Temperature)

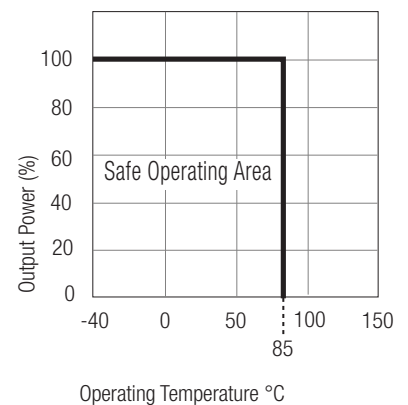

Refer to Application Notes

Typical Characteristics

R1SE-0505

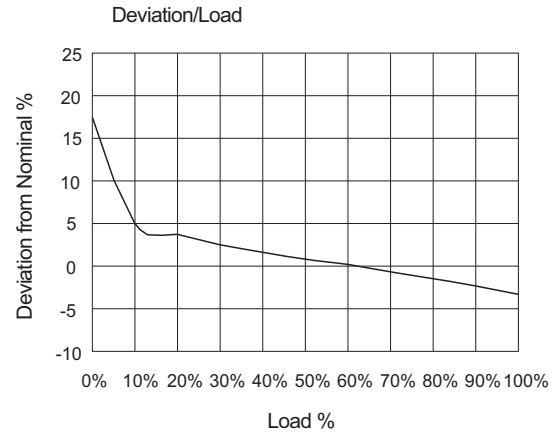
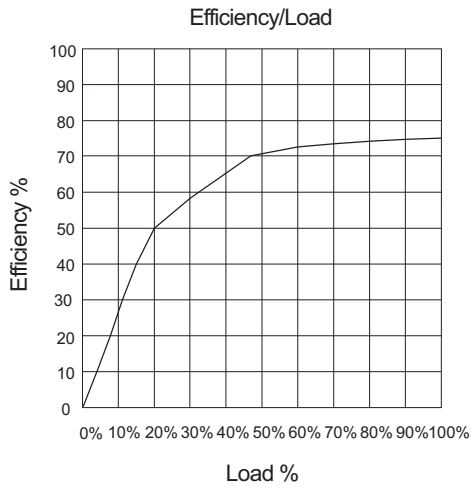

Package Style and Pinning (mm)

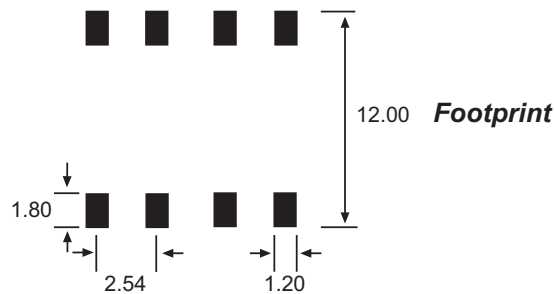
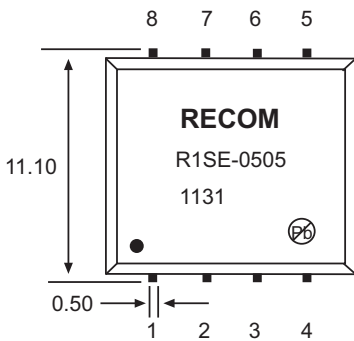
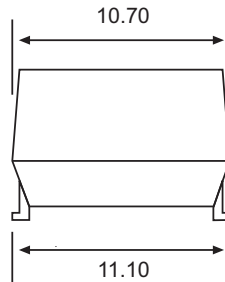
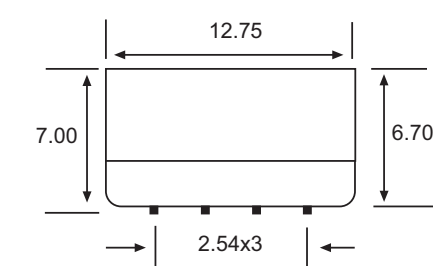

Pin Connections

Pin #	Function for 5 Pins	Function for 8 Pins
1	-Vin	-Vin
2	+Vin	+Vin
4	-Vout	-Vout
5	+Vout	+Vout
3, 6, 7	No Pin	NC
8	NC	NC

NC= No Connection

UNIT: mm
TOL.: ± 0.25 mm

Features

Unregulated Converters

- Ultra-compact - only 8.3 x 8.3 x 6.8mm
- 1kVDC or 2kVDC Isolation
- No External Components Required
- Optional Continuous Short Circuit Protected
- Fully Encapsulated
- UL and EN Certified, CB Report
- Efficiency to 84%

Description

The RNM series DC/DC converters are ultra-compact isolated single output converters for applications where board space is at a premium. Despite their small size, the converters are fully featured with a full industrial operating temperature range of -40°C to +85°C without derating (+100°C with derating), 1kVDC or 2kVDC isolation and optional short circuit protection. The converters are also UL-60950 and EN-60950 certified and have a CB Report.

Selection Guide

Part Number		Input Voltage (VDC)	Output Voltage (VDC)	Output Current (mA)	Efficiency (%)	Max. Capacitive Load ⁽¹⁾
RNM-xx3.3S	(H)	3.3, 5, 12, 15	3.3	303	75	2200µF
RNM-xx05S	(H)	3.3, 5, 12, 15	5	200	70-78	1000µF
RNM-xx09S	(H)	3.3, 5, 12, 15	9	111	70-78	1000µF
RNM-xx12S	(H)	3.3, 5, 12, 15	12	83	76-78	470µF
RNM-xx15S	(H)	3.3, 5, 12, 15	15	66	78-84	470µF

x = Input Voltage (other input and output voltage combinations available on request)

* add Suffix "P" for Continuous Short Circuit Protection, e.g. RNM-0505S/P, RNM-0505S/HP

Specifications (measured at T_A = 25°C, nominal input voltage, full load and after warm-up)

Input Voltage Range		±10%
Output Voltage Accuracy		±5%
Line Voltage Regulation		1.2%/1% of Vin typ.
Load Voltage Regulation (10% to 100% full load)	3.3V output type	20% max.
	5V output type	15% max.
	9V, 12V and 15V output types	10% max.
Output Ripple and Noise (20MHz limited)		100mVp-p max.
Operating Frequency		50kHz min. / 100kHz typ. / 105kHz max.
Efficiency at Full Load		70% min.
Minimum Load = 0%		Specifications valid for 10% minimum load only.
Isolation Voltage	(tested for 1 second)	1000VDC
	(rated for 1 minute**)	500VAC / 60Hz
Isolation Voltage	H-Suffix (tested for 1 second)	2000VDC
Rated Working Voltage	H-Suffix (rated for 1 minute**)	1000VAC / 60Hz
Isolation Capacitance		20pF min. / 75pF max.
Isolation Resistance		10 GΩ min.
Short Circuit Protection		1 Second
P-Suffix		Continuous
Operating Temperature Range (free air convection)		-40°C to +85°C (see Graph)
Storage Temperature Range		-55°C to +125°C
Relative Humidity		95% RH
Package Weight		1.1g
Packing Quantity		60 pcs per Tube

continued on next page

ECONOLINE

DC/DC-Converter

with 3 year Warranty

RECOM

1 Watt

DIP6

Single Output

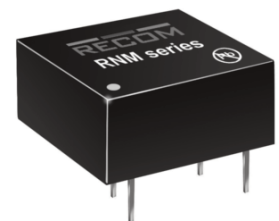

UL-60950-1 Certified
EN-60950-1 Certified

RNM

Derating-Graph (Ambient Temperature)

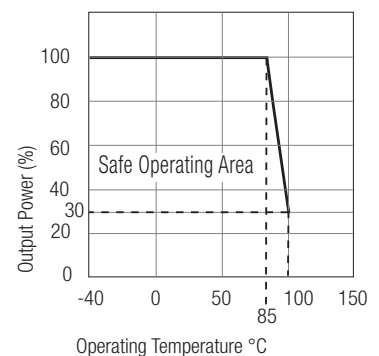

Refer to Application Notes

www.recom-power.com

**Any data referred to in this datasheet are of indicative nature and based on our practical experience only. For further details, please refer to our Application Notes.

Specifications (cont.)

MTBF (+25°C)	} Detailed Information see Application Notes chapter "MTBF"	using MIL-HDBK 217F	977 x 10 ³ hours
(+85°C)		using MIL-HDBK 217F	189 x 10 ³ hours

Certifications

CB Test Report	Report: US/13859/UL	IEC 60950-1:2005 2nd Ed.
UL General Safety	Report: E358085	UL 60950-1 1st Ed.
EN General Safety	Report: SPCLVD1109103	EN60950-1:2006+A12:2011

Notes

Note 1 Maximum capacitive load is defined as the capacitive load that will allow start up in under 1 second without damage to the converter.

Tolerance Envelope

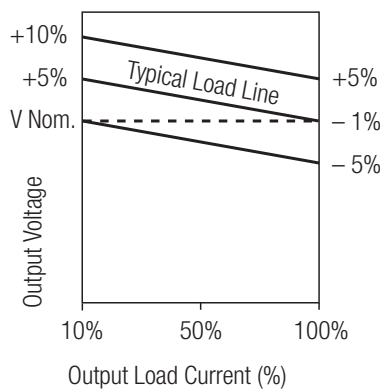

Typical Characteristics

RNM-xx05S

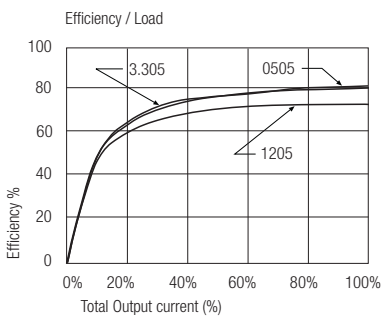

RNM-xx12S

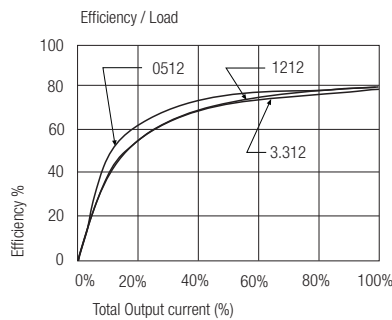

RNM-xx15S

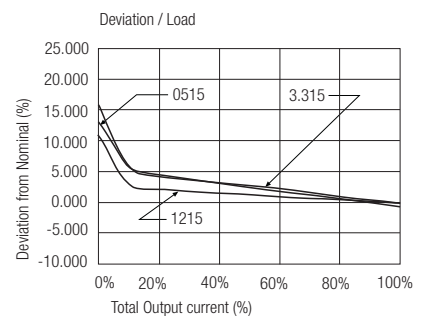
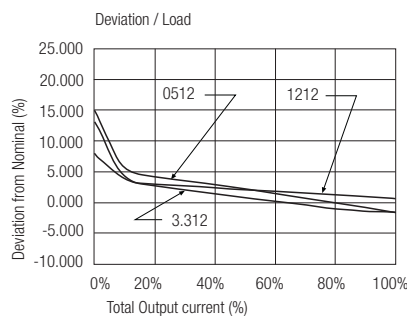
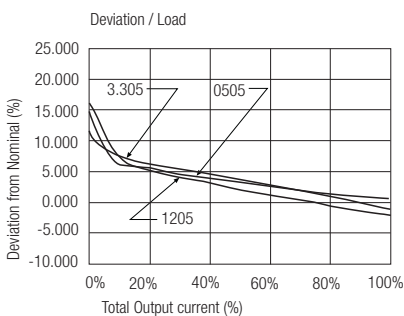
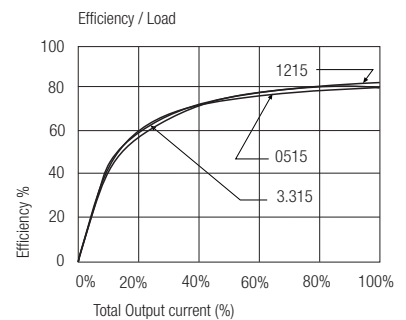

Package Style and Pinning (mm)

4 PIN DIP Package

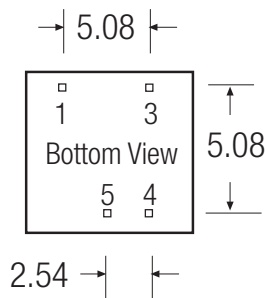
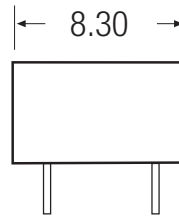
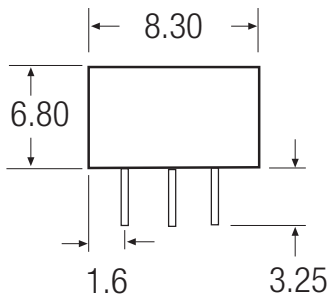

RNM Pin Connections

Pin #	Single
1	-Vin
3	+Vin
4	+Vout
5	-Vout

XX.XX ± 0.25 mm

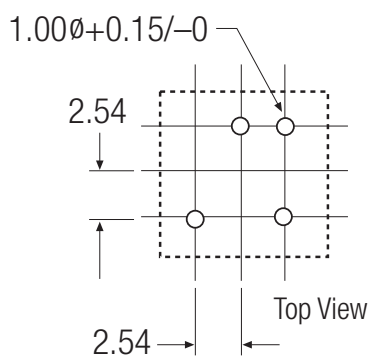

Recommended Footprint Details

Features

Unregulated Converters

- Micro Size SIP4 Package
- 3kVDC Isolation
- Approved for Medical Applications
- Industry Standard Pinout
- Optional Continuous Short Circuit Protected
- UL94V-0 Package Material
- Efficiency to 85 %

Description

The ROM Micro Size DC/DC converter has been designed for isolating or converting DC power rails where board height is at a premium. Although it has a micro-size 7.7mm package, it does not compromise on features and offers a high 3kVDC Isolation, a -40°C to +85°C operating temperature range and optional continuous short circuit protection.

Selection Guide

Part Number SIP4 Micro Size Pack.	Input Voltage (VDC)	Output Voltage (VDC)	Output Current (mA)	Efficiency (%)	Max. Capacitive Load ⁽¹⁾
ROM-xx05S	3.3, 5, 12	5	200	70-78	1000µF
ROM-xx12S	3.3, 5, 12	12	83	78-82	470µF
ROM-xx15S	3.3, 5, 12	15	66	80-84	470µF

xx = Input Voltage (other input and output voltage combinations available on request)

* add Suffix "P" for Continuous Short Circuit Protection, e.g. ROM-0505S/P

Specifications (measured at T_A = 25°C, nominal input voltage, full load and after warm-up)

Input Voltage Range		±10%
Output Voltage Accuracy		±5%
Line Voltage Regulation		1.2%/1% of V _{in} typ.
Load Voltage Regulation	5V Output	15% max.
(10% to 100% full load)	12V, 15V Output	10% max.
Output Ripple and Noise (20MHz limited)		100mVp-p max.
Operating Frequency		50kHz min. / 100kHz typ. / 105kHz max.
Efficiency at Full Load		70% min. / 80% typ.
Minimum Load = 0%	Specifications valid for 10% minimum load only.	
Isolation Voltage	(tested for 1 second)	3000VDC
	(rated for 1 minute**)	1500VAC / 60Hz
Isolation Capacitance		20pF min. / 75pF max.
Isolation Resistance		15 GΩ min.
Short Circuit Protection		1 Second
P-Suffix		Continuous
Operating Temperature Range (free air convection)		-40°C to +85°C (see Graph)
Storage Temperature Range		-55°C to +125°C
Relative Humidity		95% RH
Package Weight		1g
Packing Quantity		42 pcs per Tube
MTBF (+25°C)	} Detailed Information see Application Notes chapter "MTBF"	using MIL-HDBK 217F
(+85°C)		using MIL-HDBK 217F
		977 x 10 ³ hours
		189 x 10 ³ hours
Certifications		
CB Test Report	Report: US/15348/UL	IEC 60950-1:2005 2nd Ed.
UL General Safety	Report: E350805	UL 60950-1 2nd Ed.
EN General Safety	Report: SPLVD1109103	EN60950-1:2006 + A12:2011
EN Medical Safety	Report: MDD1205098-4 + RM1205098-4	IEC/EN 60601-1 3rd Edition Medical Report + ISO14971 Risk Assessment

**Any data referred to in this datasheet are of indicative nature and based on our practical experience only. For further details, please refer to our Application Notes.

ECONOLINE

DC/DC-Converter

with 3 year Warranty

RECOM

1 Watt SIP4 Micro Single Output



E-358085

EN-60950-1 Certified

UL-60950-1 Certified

EN-60601-1 Certified

ROM

Derating-Graph (Ambient Temperature)

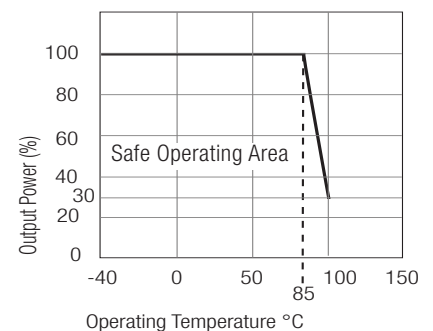

Refer to Application Notes

Typical Characteristics

ROM-xx05S

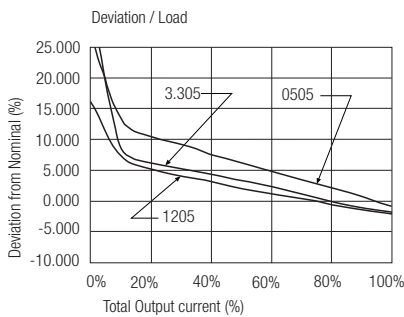
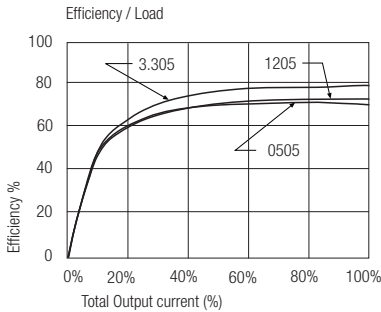

ROM-xx12S

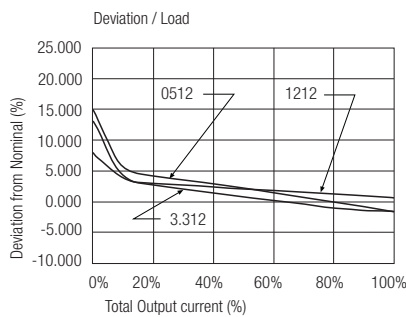
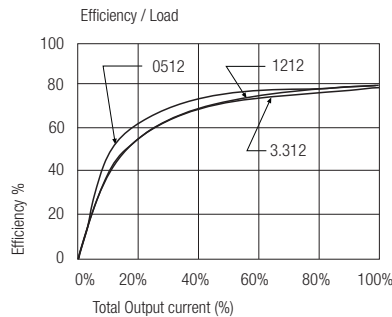

ROM-xx15S

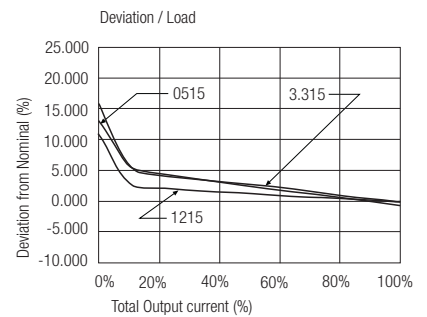
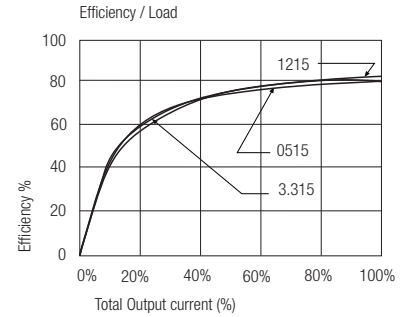

Notes

Note 1 Maximum capacitive load is defined as the capacitive load that will allow start up in under 1 second without damage to the converter.

Package Style and Pinning (mm)

4 PIN SIP Micro Size Package

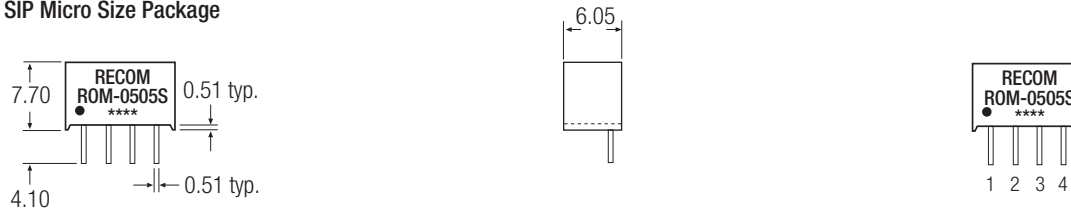

Recommended Footprint Details

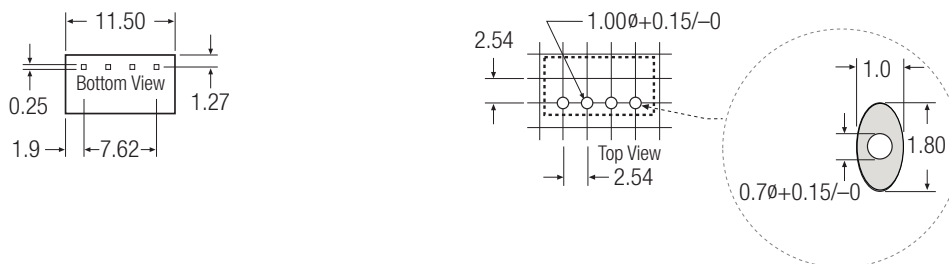

RO Pin Connections

Pin #	Single
1	-Vin
2	+Vin
3	-Vout
4	+Vout
XX.X ± 0.5 mm	
XX.XX ± 0.25 mm	

Features

Unregulated Converter

- Industry Standard Pinout
- 1kVDC or 2kVDC Isolation
- UL94V-0 Package Material
- Optional Continuous Short Circuit Protected
- Fully Encapsulated
- Custom Solutions Available
- Efficiency to 85 %

Description

The RO DC/DC converters are typically used in general purpose power isolation and voltage matching applications, and feature a full industrial operating temperature range of -40°C to +85°C without derating.

Selection Guide

Part Number	(2kV)	Input Voltage (VDC)	Output Voltage (VDC)	Output Current (mA)	Efficiency (%)	Max. Capacitive Load ⁽¹⁾
RO-xx3.3S	(H)	3.3, 5, 12, 15, 24	3.3	303	75	2200µF
RO-xx05S	(H)	3.3, 5, 12, 15, 24	5	200	78-80	1000µF
RO-xx09S	(H)	3.3, 5, 12, 15, 24	9	111	78-80	1000µF
RO-xx12S	(H)	3.3, 5, 12, 15, 24	12	83	80-84	470µF
RO-xx15S	(H)	3.3, 5, 12, 15, 24	15	66	80-84	470µF
RO-xx24S	(H)	3.3, 5, 12, 15, 24	24	42	78-85	220µF

xx = Input Voltage (other input and output voltage combinations available on request)

* add Suffix "P" for Continuous Short Circuit Protection, e.g. RO-0505S/P, RO-0505S/HP

Specifications (measured at T_A = 25°C, nominal input voltage, full load and after warm-up)

Input Voltage Range			±10%
Output Voltage Accuracy			±5%
Line Voltage Regulation			1.2%/1% of Vin typ.
Load Voltage Regulation (10% to 100% full load)	3.3V output type		20% max.
	5V output type		15% max.
	9V, 12V, 15V, 24V output types		10% max.
Output Ripple and Noise (20MHz limited)			100mVp-p max.
Operating Frequency			50kHz min. / 100kHz typ. / 105kHz max.
Efficiency at Full Load			70% min. / 80% typ.
Minimum Load = 0%			Specifications valid for 10% minimum load only.
Isolation Voltage	(tested for 1 second)		1000VDC
	(rated for 1 minute**)		500VAC / 60Hz
Isolation Voltage	H-Suffix	(tested for 1 second)	2000VDC
	H-Suffix	(rated for 1 minute**)	1000VAC / 60Hz
Isolation Capacitance			20pF min. / 75pF max.
Isolation Resistance			10 GΩ min.
Short Circuit Protection			1 Second
P-Suffix			Continuous
Operating Temperature Range (free air convection)			-40°C to +85°C (see Graph)
Storage Temperature Range			-55°C to +125°C
Relative Humidity			95% RH
Package Weight			1.4g
Packing Quantity			42 pcs per Tube
MTBF (+25°C)	} Detailed Information see Application Notes chapter "MTBF"	using MIL-HDBK 217F	985 x 10 ³ hours
		using MIL-HDBK 217F	200 x 10 ³ hours

continued on next page

**Any data referred to in this datasheet are of indicative nature and based on our practical experience only. For further details, please refer to our Application Notes.

ECONOLINE

DC/DC-Converter

with 3 year Warranty

RECOM

1 Watt

SIP4

Single Output

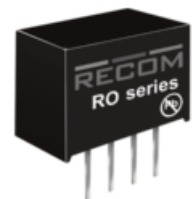

EN-60950-1 Certified
UL-60950-1 Certified
EN-60601-1 Certified*
 (* /H suffix)

RO

Derating-Graph (Ambient Temperature)

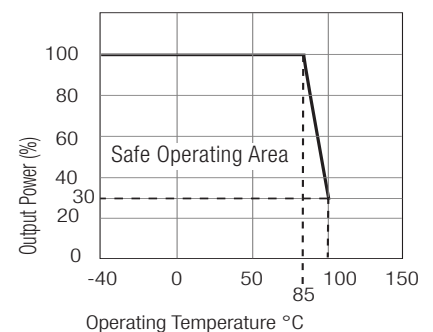

Refer to Application Notes

Specifications (measured at $T_A = 25^\circ\text{C}$, nominal input voltage, full load and after warm-up)

Certifications

CB Test Report	Report: US/15348/UL	IEC 60950-1:2005 2nd Ed.
UL General Safety	Report: E358085	UL 60950-1 2nd Ed.
EN General Safety	Report: SPCLVD1109103	EN60950-1:2006 + A12:2011
EN Medical Safety	Report: MDD1112018 + RM1112018	IEC/EN 60601-1 3rd Edition Medical Report + ISO14971 Risk Assessment

Notes
 Note 1 Maximum capacitive load is defined as the capacitive load that will allow start up in under 1 second without damage to the converter.

Typical Characteristics

RO-xx05S

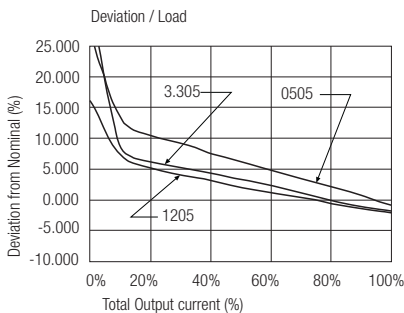
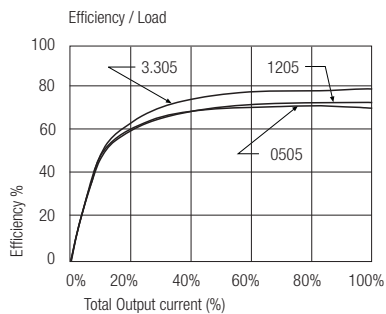

RO-xx12S

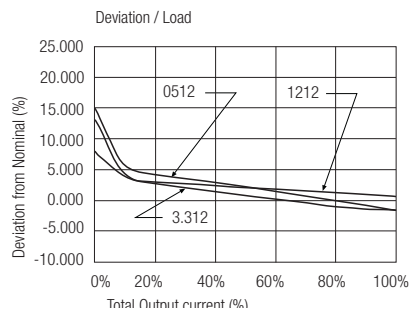
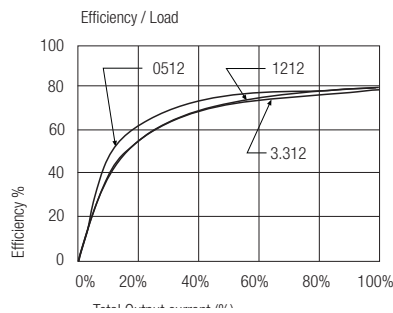

RO-xx15S

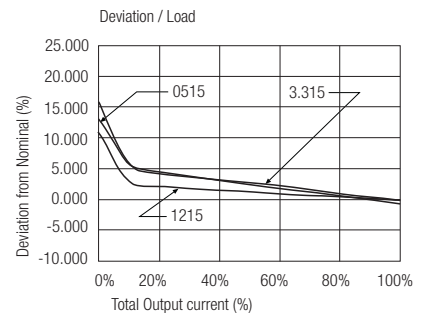
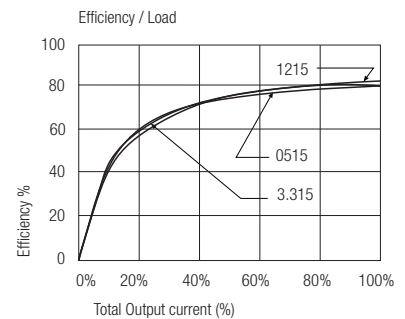

Package Style and Pinning (mm)

4 PIN SIP Package

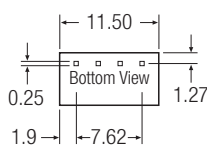
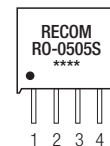
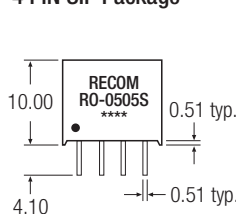

Recommended Footprint Details

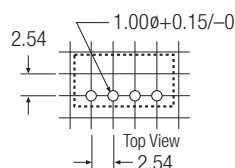

RO Pin Connections

Pin #	Single
1	-Vin
2	+Vin
3	-Vout
4	+Vout

XX.X ± 0.5 mm
 XX.XX ± 0.25 mm

The product information and specifications are subject to change without prior notice. All products are designed for non-safety critical commercial and industrial applications. The Buyer agrees to implement safeguards that anticipate the consequences of any failures that might cause harm, loss of life and/or damage property.

Features

Unregulated Converters

- High Efficiency up to 84%
- Low Deviation (10% ~ 100% Load)
- 1kVDC and 2kVDC Isolation Option
- Safety Certified
- -40°C to +100°C Operating Temperature Range
- 1W SIP4 Package

Description

The RO/E series is an unregulated DC/DC converter in standard SIP4 package style. This series has been designed to offer exceptionally high efficiency at low loads, an extended operating temperature range and low deviation (10% to 100% load). Uses include applications with restricted energy budget and industrial applications where a high efficiency level is required.

Selection Guide

Part Number SMD	Isolation Voltage (kVDC)	Input Voltage (VDC)	Output Voltage (VDC)	Output Current (mA)	Efficiency (typ.)	Capacitive Load (max.) ⁽¹⁾
RO-3.305S/E*	1	3.3	5	200	83%	2200µF
RO-0505S/E*	1	5	5	200	84%	2200µF
RO-1205S/E*	1	12	5	200	84%	2200µF
RO-2405S/E*	1	24	5	200	81%	2200µF

* add Suffix "/H" for 2kVDC Isolation Voltage - e.g. RO-3.305S/EH

* add Suffix "/P" for Continuous Short Protection - e.g. RO-3.305S/EHP, RO-3.305S/EP

Specifications (measured at T_A = 25°C, nominal input voltage, full load and after warm-up)

Input Voltage Range			±10%
Output Voltage Accuracy			±5% max.
Line Voltage Regulation	low line to high line at full load		1.2% max.
Load Voltage Regulation	Load Deviation 10% to 100%		12% typ.
Output Ripple and Noise (20MHz BW)			50mVp-p typ., 100mVp-p max.
Operating Frequency (Vin=nominal input)			20kHz min. / 90kHz max.
Efficiency			see Selection Guide
Minimum Load = 0%	Specifications valid for 10% minimum load only		
Isolation Voltage	(tested for 1 second)		1000 VDC
	(rated for 1 minute**)		500VAC / 60Hz
Isolation Voltage	H-Suffix	(tested for 1 second)	2000 VDC
	H-Suffix	(rated for 1 minute**)	1000VAC / 60Hz
Isolation Capacitance			75pF max.
Isolation Resistance	(Viso=500V)		10GΩ min.
Short-Circuit Protection			1 second
Operating Temperature Range			-40°C to +100°C
Storage Temperature			-55°C to +125°C
Relative Humidity			95% RH
Package Weight			1.4g
MTBF (+25°C)	} Detailed Information see Application Notes chapter "MTBF"	using MIL-HDBK 217F	3459 x 10 ³ hours
MTBF (+100°C)		using MIL-HDBK 217F	756 x 10 ³ hours

**Any data referred to in this datasheet are of indicative nature and based on our practical experience only. For further details, please refer to our Application Notes.

ECONOLINE

DC/DC-Converter
with 3 year Warranty

RECOM

1 Watt SIP4 Single Output



EN-60950-1 (pending)
UL-60950-1 (pending)

RO/E

Derating-Graph (Ambient Temperature)

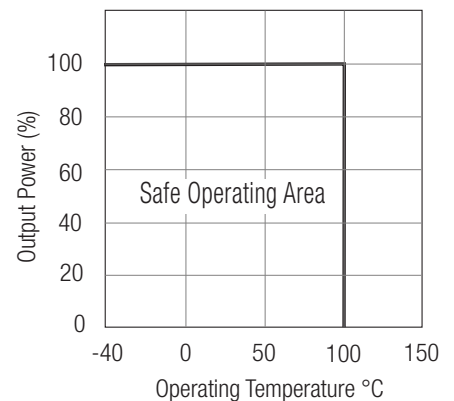

Refer to Application Notes

Notes

Note 1: Maximum capacitive load is defined as the capacitive load that will allow start up in under 1 second without damage to the converter.

Typical Characteristics

RO-xx05S/E

Tolerance Envelope

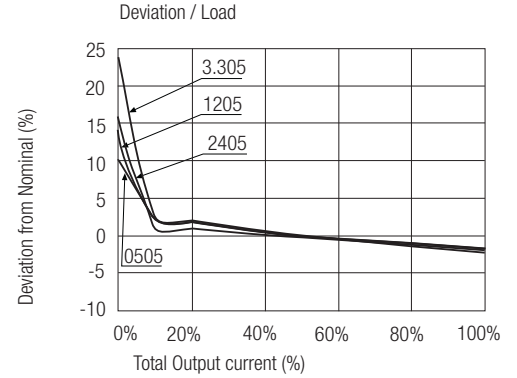
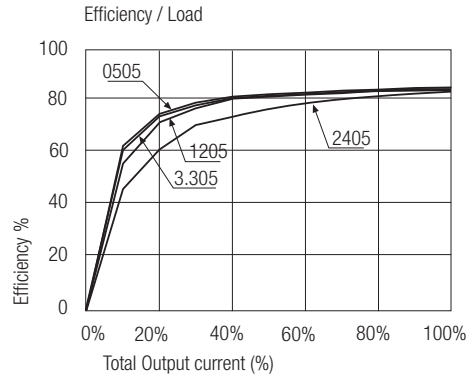
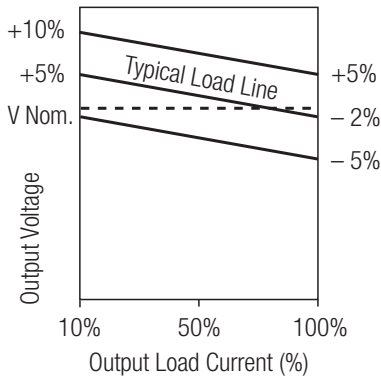

Package Style and Pinning

RO/E

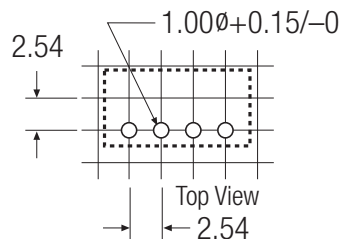
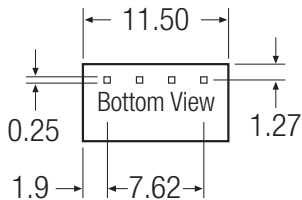
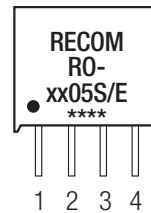
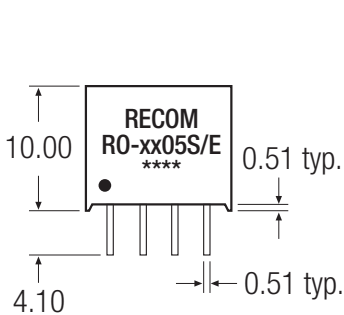

Pin #	Function
1	-Vin
2	+Vin
3	-Vout
4	+Vout

Unit: mm
Tolerance: ± 0.25 mm

Features

Unregulated Converters

- 1:1 Input Range
- Low Cost 1W Converter
- Efficiency to 75%
- -40°C to +85°C Operating Temperature Range
- UL Certified

Selection Guide

Part Number SMD	Input Voltage (VDC)	Output Voltage (VDC)	Output Current (mA)	Efficiency (typ.)
ROE-0505S	5	5	200	75%

Specifications (measured at $T_A = 25^\circ\text{C}$, nominal input voltage, full load and after warm-up)

Input Voltage Range		$\pm 10\%$ max.	
Output Voltage Accuracy		-2% typ., $\pm 5\%$ max.	
Line Voltage Regulation	(low line to high line at max. load)	1.2% typ.	
	20% to 100% load (5V output)	10% max.	
Output Ripple and Noise (20MHz BW limited)		52mVp-p typ. / 100mVp-p max.	
Operating Frequency (V_{in} =nominal input)		50kHz min. / 82kHz typ. / 105kHz max.	
Efficiency		75% typ. / 70% min.	
Isolation Test Voltage	(tested for 1 second)	1000 VDC min.	
	(rated for 1 minute*)	500VAC / 60Hz	
Isolation Capacitance		75pF max.	
Isolation Resistance	($V_{iso}=500V$)	1G Ω min.	
Short-Circuit Protection		1 sec.	
Operating Temperature Range		-40°C to +85°C	
Storage Temperature		-55°C to +125°C	
Relative Humidity		95% RH	
Package Weight		1.4g	
MTBF (+25°C)	} Detailed Information see Application Notes chapter "MTBF"	using MIL-HDBK 217F	2400 x 10 ³ hours
MTBF (+85°C)		using MIL-HDBK 217F	650 x 10 ³ hours
Certification			
UL General Safety	Report: E358085-A4		UL60950-1

*Any data referred to in this datasheet are of indicative nature and based on our practical experience only. For further details, please refer to our Application Notes.

Typical Characteristics

Tolerance Envelope

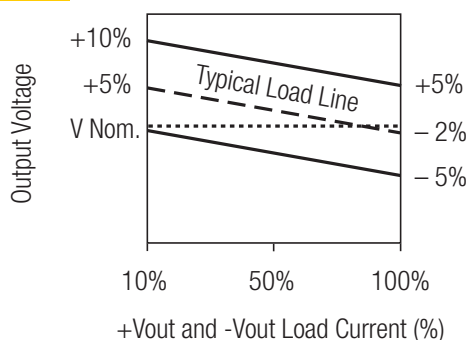

ECONOLINE

DC/DC-Converter

with 3 year Warranty

RECOM

1 Watt SIP4 Single Output



E-ALUS
E-358085

UL-60950-1 Certified

ROE

Derating-Graph (Ambient Temperature)

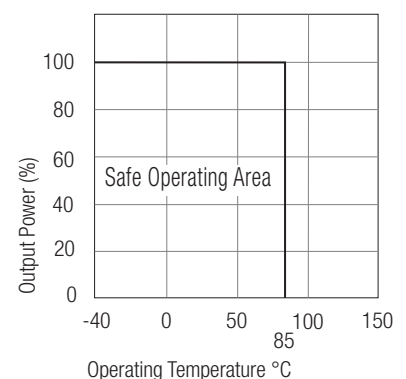

Refer to Application Notes

Typical Characteristics

ROE-0505S

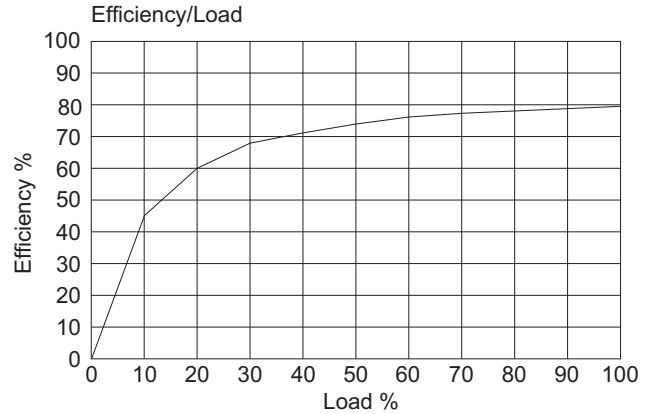
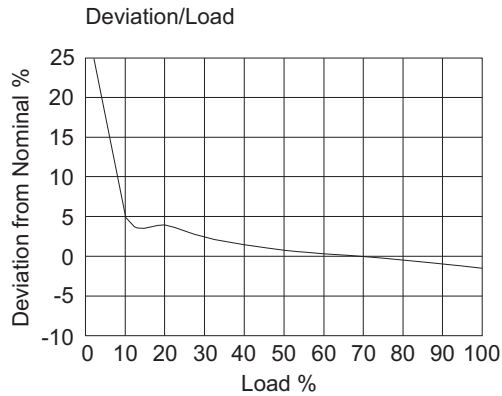

Package Style and Pinning

Single SIP 4PIN Package

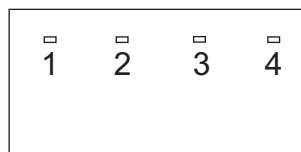
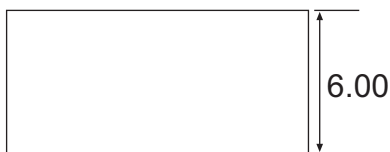

BOTTOM VIEW

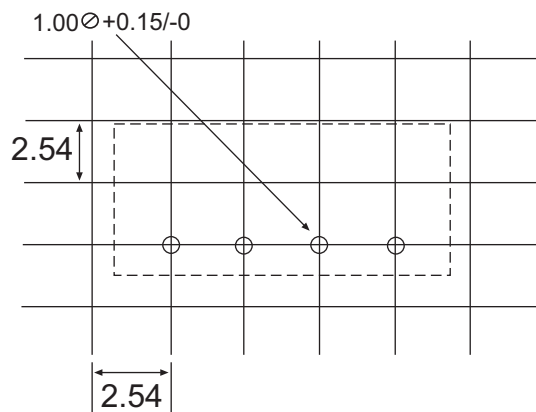
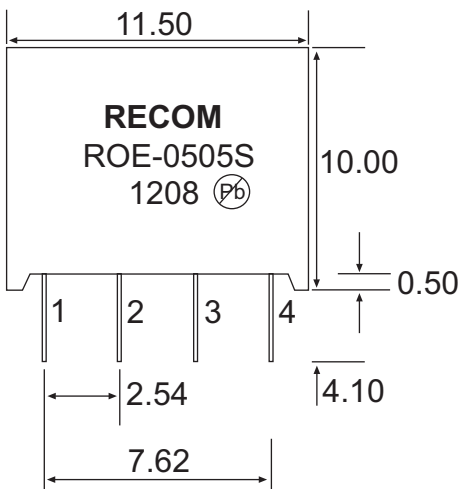

Pin Connections

Pin #	Function
1	-Vin
2	+Vin
3	-Vout
4	+Vout

Unit: mm
Tolerance: ± 0.25 mm

ROE

Features

Unregulated Converters

- Micro Size SIP 6 Package
- Industry Standard Pinout
- Power Sharing on Dual Output Version
- 3kVDC Isolation
- Optional Continuous Short Circuit Protected
- Efficiency to 85 %

Description

The RBM Micro Size DC/DC-Converter complements Recom's industrial range of converters. This range is widely used for pcb distributed power systems and combines small package size, high efficiency, 3kVDC isolation and low output ripple.

The extended operating temperature range covering -40°C to +85°C is a standard feature. The full rated power can be taken from a single pin of this dual output converter, provided this does not exceed 1 Watt.

Selection Guide

Part Number SIP 6 Micro Size	Input Voltage (VDC)	Output Voltage (VDC)	Output Current (mA)	Efficiency (%)	Max Capacitive Load ⁽¹⁾
RBM-xx05S	5, 12	5	200	70-78	1000µF
RBM-xx12S	5, 12	12	83	78-80	470µF
RBM-xx15S	5, 12	15	66	80-84	470µF
RBM-xx05D	5, 12	±5	±100	74-78	±470µF
RBM-xx12D	5, 12	±12	±41	80-82	±220µF
RBM-xx15D	5, 12	±15	±33	80-84	±220µF

xx = Input Voltage. Other input and output voltage combinations available on request.

* add Suffix "P" for Continuous Short Circuit Protection, e.g. RBM-0505S/P, RBM-0505D/P

Specifications (measured at T_A = 25°C, nominal input voltage, full load and after warm-up)

Input Voltage Range		±10%
Output Voltage Accuracy		±5%
Line Voltage Regulation		1.2%/1% of Vin typ.
Load Voltage Regulation	5V output type	15% max
(10% to 100% full load)	12, 15V output types	10% max
Output Ripple and Noise (20MHz limited)		100mVp-p max.
Operating Frequency		50kHz min. / 100kHz typ. / 105kHz max.
Efficiency at Full Load		70% min. / 80% typ.
Minimum Load = 0%	Specifications valid for 10% minimum load only.	
Isolation Voltage	(tested for 1 second) (rated for 1 minute**)	3000VDC 1500VAC / 60Hz
Isolation Capacitance		20pF min. / 65pF max.
Isolation Resistance		15 GΩ min.
Short Circuit Protection		1 Second
P-Suffix		Continuous
Operating Temperature Range (free air convection)		-40°C to +85°C (see Graph)
Storage Temperature Range		-55°C to +125°C
Relative Humidity		95% RH
Package Weight		1.3g
Packing Quantity		30 pcs per Tube
MTBF (+25°C)	} Detailed Information see Application Notes chapter "MTBF"	using MIL-HDBK 217F
(+85°C)		using MIL-HDBK 217F
Certifications		
CB Test Report	Report: US/15348/UL	IEC 60950-1:2005 2nd Ed.
UL General Safety	Report: E358085	UL 60950-1 2nd Ed.
EN General Safety	Report: SPCLVD1109103	EN60950-1:2001 + A11:2004
EN Medical Safety	Report: MDD1205098-4 + RM1205098-4IEC/EN 60601-1 3rd Edition	Medical Report + ISO14971 Risk Assessment

ECONOLINE

DC/DC-Converter

with 3 year Warranty

RECOM

1 Watt

SIP 6 Micro Size, Single & Dual Output

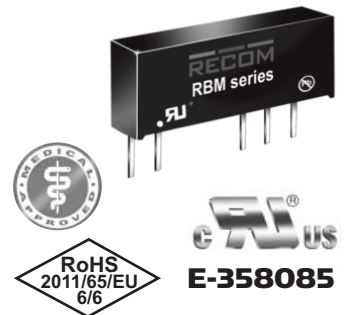

EN-60950-1 Certified
UL-60950-1 Certified
EN-60601-1 Certified

RBM

Derating-Graph (Ambient Temperature)

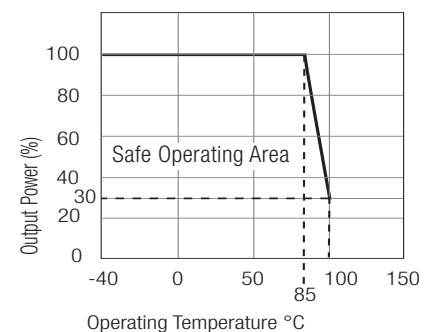

**Any data referred to in this datasheet are of indicative nature and based on our practical experience only. For further details, please refer to our Application Notes.

Refer to Application Notes

Specifications (measured at $T_A = 25^\circ\text{C}$, nominal input voltage, full load and after warm-up)

Notes
 Note 1 Maximum capacitive load is defined as the capacitive load that will allow start up in under 1 second without damage to the converter.

Typical Characteristics

RBM-xx05S

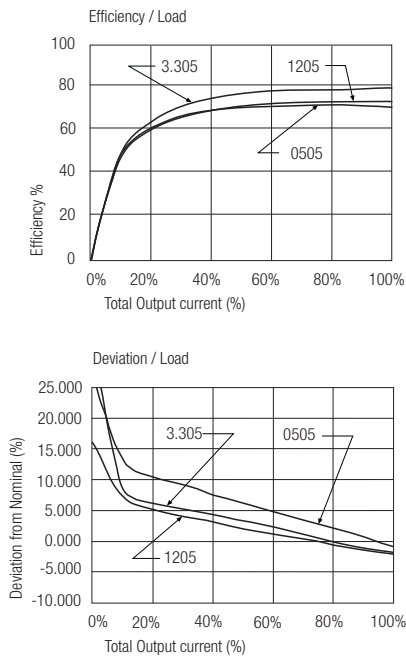

RBM-xx12S

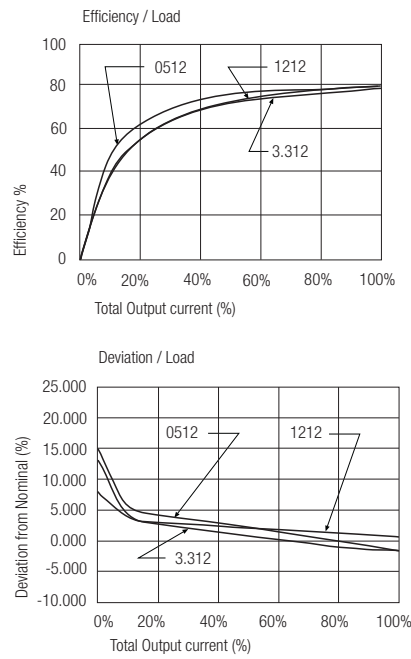

RBM-xx05D

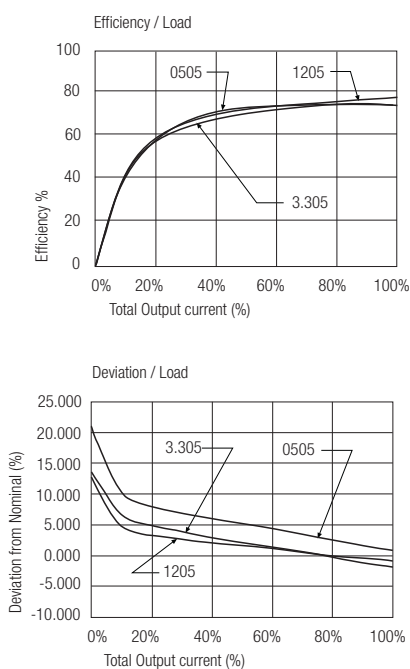

RBM-xx12D

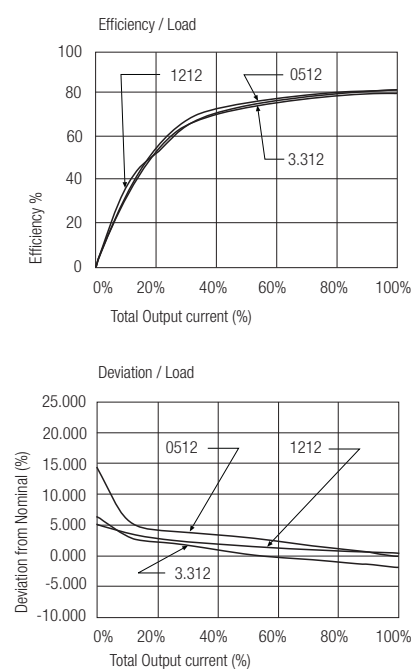

Typical Characteristics

RBM-xx15S

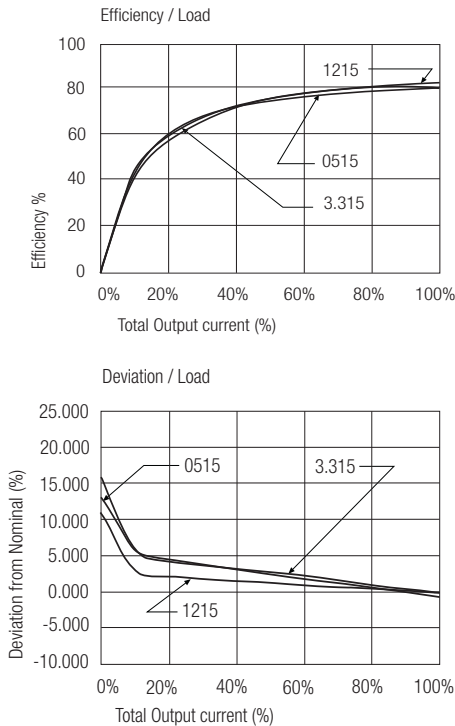

RBM-xx15D

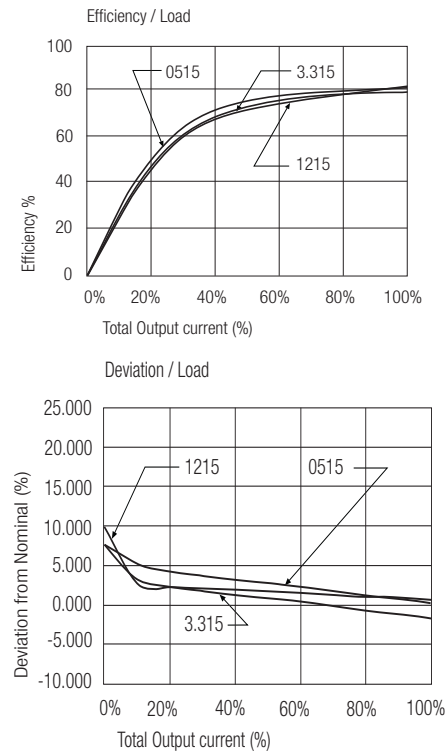

Package Style and Pinning (mm)

SIP6 Micro Size Package

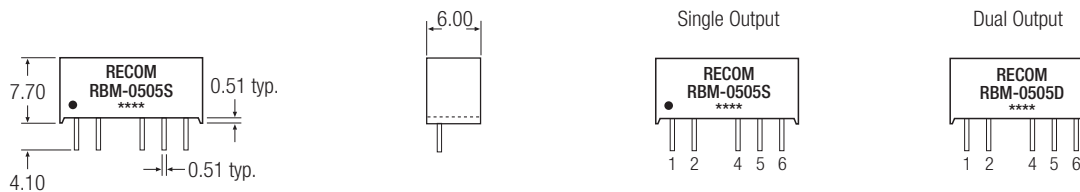

Recommended Footprint Details

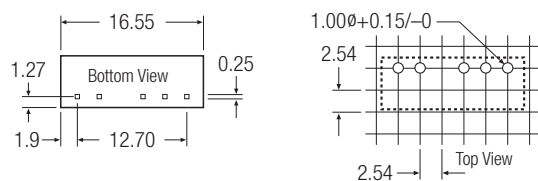

Pin Connections

Pin #	Single	Dual
1	+Vin	+Vin
2	-Vin	-Vin
4	NC	-Vout
5	-Vout	Com
6	+Vout	+Vout

NC = No Connection
XX.X ± 0.5 mm
XX.XX ± 0.25 mm

The product information and specifications are subject to change without prior notice. All products are designed for non-safety critical commercial and industrial applications. The Buyer agrees to implement safeguards that anticipate the consequences of any failures that might cause harm, loss of life and/or damage property.

Features

Unregulated Converters

- Low Cost 1W Converter
- Power Sharing on Dual Output Version
- Industry Standard Pinout
- 1kVDC or 2kVDC Isolation Options
- Optional Continuous Short Circuit Protected
- UL94V-0 Package Material
- Efficiency to 85 %

Description

The RB series DC/DC converter has been designed for isolating or converting DC power rails in general purpose applications. Although low cost, it does not compromise on features and offers 1KVDC or 2kVDC isolation, a -40°C to +85°C operating temperature range and optional continuous short circuit protection.

Selection Guide

Part Number	(2kV)	Input Voltage (VDC)	Output Voltage (VDC)	Output Current (mA)	Efficiency (%)	Max Capacitive Load ⁽¹⁾
RB-xx3.3S	(H)	3.3, 5, 12, 15, 24	3.3	303	75	2200µF
RB-xx05S	(H)	3.3, 5, 12, 15, 24	5	200	70-78	1000µF
RB-xx09S	(H)	3.3, 5, 12, 15, 24	9	111	70-78	1000µF
RB-xx12S	(H)	3.3, 5, 12, 15, 24	12	84	78-80	470µF
RB-xx15S	(H)	3.3, 5, 12, 15, 24	15	66	80-84	470µF
RB-xx24S	(H)	3.3, 5, 12, 15, 24	24	42	74-85	220µF
RB-xx3.3D	(H)	3.3, 5, 12, 15, 24	±3.3	±152	70	±1000µF
RB-xx05D	(H)	3.3, 5, 12, 15, 24	±5	±100	70-78	±470µF
RB-xx09D	(H)	3.3, 5, 12, 15, 24	±9	±56	76-79	±470µF
RB-xx12D	(H)	3.3, 5, 12, 15, 24	±12	±42	78-82	±220µF
RB-xx15D	(H)	3.3, 5, 12, 15, 24	±15	±33	80-84	±220µF
RB-xx24D	(H)	3.3, 5, 12, 15, 24	±24	±21	80-84	±100µF

xx = Input Voltage. Other input and output voltage combinations available on request.

* add Suffix "P" for Continuous Short Circuit Protection, e.g. RB-0505S/P, RB-0505S/HP

Specifications (measured at T_A = 25°C, nominal input voltage, full load and after warm-up)

Input Voltage Range	±10%	
Output Voltage Accuracy	±5%	
Line Voltage Regulation	1.2%/1% of Vin typ.	
Load Voltage Regulation	3.3V output type	20% max.
(10% to 100% full load)	5V output type	15% max.
	9V, 12V, 15V, 24V output types	10% max.
Output Ripple and Noise (20MHz limited)	Single output types	100mVp-p max.
	Dual output types	±75mVp-p max.
Operating Frequency	50kHz min. / 100kHz typ. / 105kHz max.	
Efficiency at Full Load	70% min. / 80% typ.	
Minimum Load = 0%	Specifications valid for 10% minimum load only.	
Isolation Voltage	(tested for 1 second)	1000VDC
	(rated for 1 minute**)	500VAC / 60Hz
Isolation Voltage	H-Suffix (tested for 1 second)	2000VDC
	H-Suffix (rated for 1 minute**)	1000VAC / 60Hz
Isolation Capacitance	20pF min. / 75pF max.	
Isolation Resistance	10 GΩ min.	
Short Circuit Protection	1 Second	
P-Suffix	Continuous	
Operating Temperature Range (free air convection)	-40°C to +85°C (see Graph)	
Storage Temperature Range	-55°C to +125°C	
Relative Humidity	95% RH	

continued to next page

ECONOLINE

DC/DC-Converter

with 3 year Warranty

RECOM

1 Watt

SIP7

Single & Dual Output



E358085

EN-60950-1 Certified
UL-60950-1 Certified
EN-60601-1 Certified*
 (* /H suffix)

RB

Derating-Graph (Ambient Temperature)

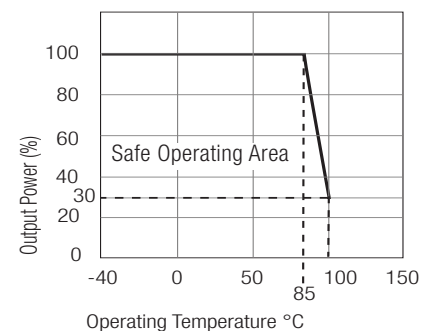

**Any data referred to in this datasheet are of indicative nature and based on our practical experience only. For further details, please refer to our Application Notes.

Refer to Application Notes

www.recom-power.com

Specifications (measured at $T_A = 25^\circ\text{C}$, nominal input voltage, full load and after warm-up)

Package Weight			2.2g
Packing Quantity			25 pcs per Tube
MTBF (+25°C)	} <i>Detailed Information see</i> <i>Application Notes chapter "MTBF"</i>	using MIL-HDBK 217F	1012 x 10 ³ hours
(+85°C)		using MIL-HDBK 217F	151 x 10 ³ hours

Certifications

CB Test Report
 UL General Safety
 EN General Safety
 EN Medical Safety

Report: SPCLVD1109103 IEC 60950-1:2005 2nd Ed.
 Report: E358085 UL 60950-1 2nd Ed.
 Report: SPCLVD1109103 EN60950-1:2006 + A12:2011
 Report: MDD1112018 + RM1112018 IEC/EN 60601-1 3rd
 Edition Medical Report + ISO14971 Risk Assessment

Typical Characteristics - Single Output

RB-xx05S

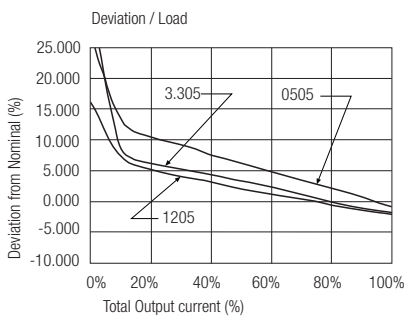
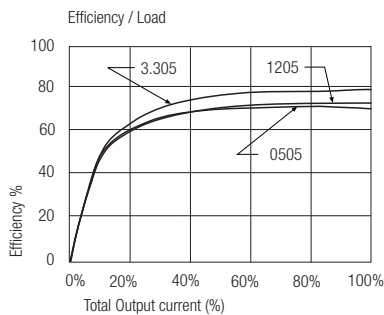

RB-xx09S

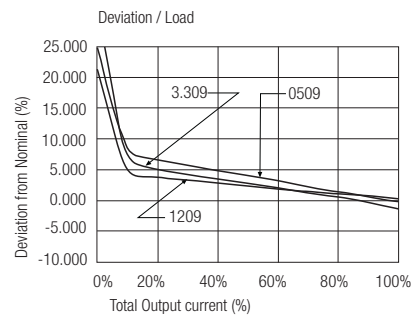
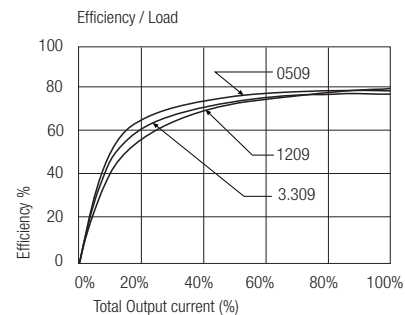

RB-xx12S

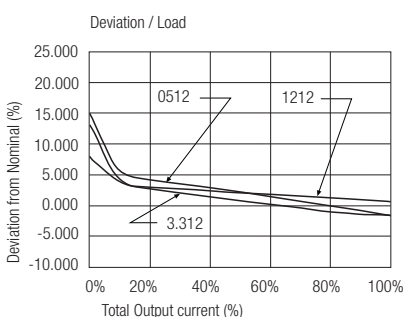
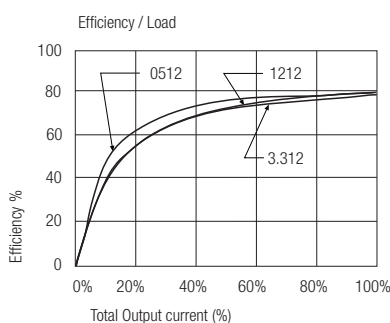

RB-xx15S

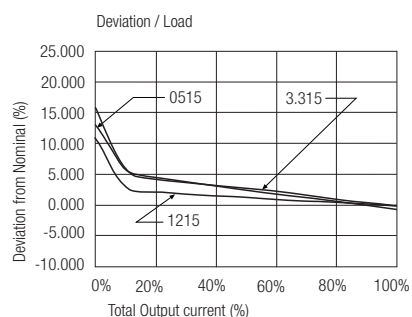
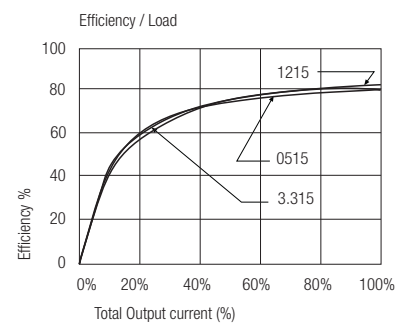

Typical Characteristics - Dual Outputs

RB-xx05D

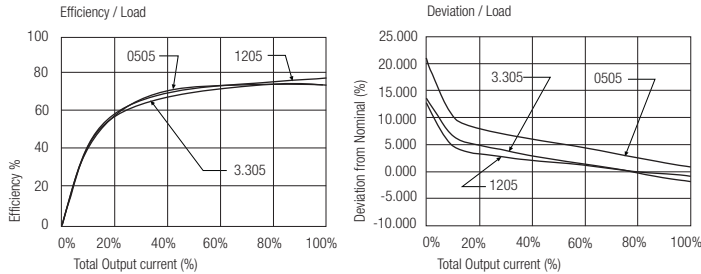

RB-xx12D

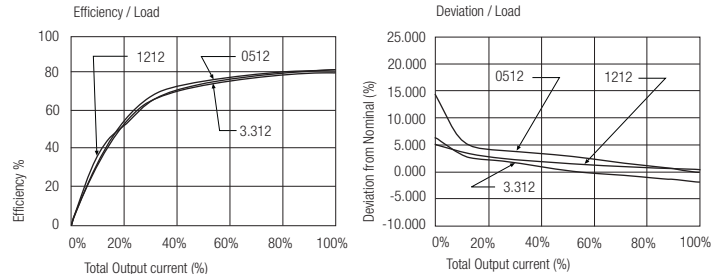

RB-xx09D

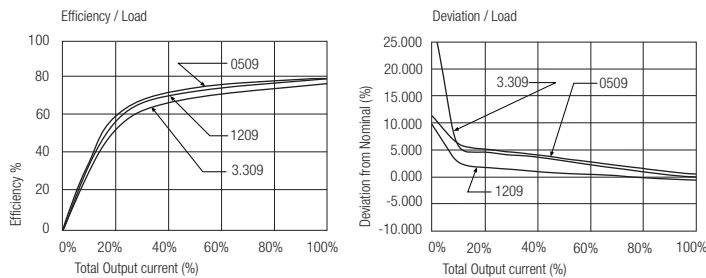

RB-xx15D

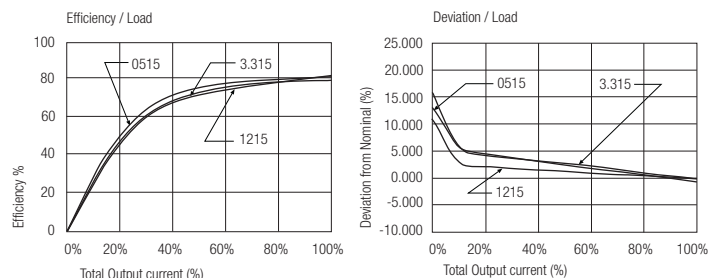

Notes
Note 1 Maximum capacitive load is defined as the capacitive load that will allow start up in under 1 second without damage to the converter.

Package Style and Pinning (mm)

SIP7 Package

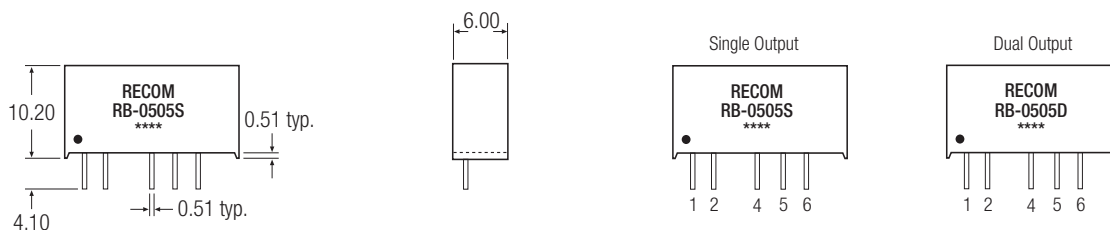

Recommended Footprint Details

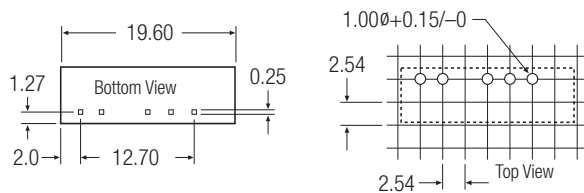

Pin Connections

Pin #	Single	Dual
1	+Vin	+Vin
2	-Vin	-Vin
4	NC	-Vout
5	-Vout	Com
6	+Vout	+Vout

NC = No Connection
XX.X ± 0.5 mm
XX.XX ± 0.25 mm

The product information and specifications are subject to change without prior notice. All products are designed for non-safety critical commercial and industrial applications. The Buyer agrees to implement safeguards that anticipate the consequences of any failures that might cause harm, loss of life and/or damage property.

Features

Unregulated Converters

- High Efficiency up to 84% Full Load
- Low Deviation (10% ~ 100% Load)
- 1kVDC and 2kVDC Isolation Option
- Safety Certified
- -40°C to +100°C Operating Temperature Range
- 1W SIP7 Package

Description

The RB/E series is an unregulated DC/DC converter in standard SIP7 package style. This series has been designed to offer exceptionally high efficiency at low loads, an extended operating temperature range and low deviation (10% to 100%). Uses include applications with restricted energy budget and industrial applications where a high efficiency level is required.

Selection Guide

Part Number SMD	Isolation Voltage (kVDC)	Input Voltage (VDC)	Output Voltage (VDC)	Output Current (mA)	Efficiency (typ.)	Capacitive Load (max.) ⁽¹⁾
RB-3.305S/E*	1	3.3	5	200	83%	2200µF
RB-0505S/E*	1	5	5	200	84%	2200µF
RB-1205S/E*	1	12	5	200	84%	2200µF
RB-2405S/E*	1	24	5	200	81%	2200µF

* add Suffix "/H" for 2kVDC Isolation Voltage - e.g. RB-3.305S/EH

* add Suffix "/P" for Continuous Short Protection - e.g. RB-3.305S/EHP, RB-3.305S/EP

Specifications (measured at T_A = 25°C, nominal input voltage, full load and after warm-up)

Input Voltage Range			±10%
Output Voltage Accuracy			±5% max.
Line Voltage Regulation	low line to high line at full load		1.2% max.
Load Voltage Regulation	Load Deviation 10% to 100%		12% typ.
Output Ripple and Noise (20MHz BW)			50mVp-p typ., 100mVp-p max.
Operating Frequency (Vin=nominal input)			20kHz min. / 90kHz max.
Efficiency			see Selection Guide
Minimum Load = 0%			Specifications valid for 10% minimum load only
Isolation Voltage	(tested for 1 second)		1000 VDC
	(rated for 1 minute**)		500VAC / 60Hz
Isolation Voltage	H-Suffix	(tested for 1 second)	2000VDC
	H-Suffix	(rated for 1 minute**)	1000VAC / 60Hz
Isolation Capacitance			75pF max.
Isolation Resistance	(Viso=500V)		10GΩ min.
Short-Circuit Protection			1 second
Operating Temperature Range			-40°C to +100°C
Storage Temperature			-55°C to +125°C
Relative Humidity			95% RH
Package Weight			2.2g
MTBF (+25°C)	} Detailed Information see Application Notes chapter "MTBF"	using MIL-HDBK 217F	3459 x 10 ³ hours
MTBF (+100°C)		using MIL-HDBK 217F	756 x 10 ³ hours

**Any data referred to in this datasheet are of indicative nature and based on our practical experience only. For further details, please refer to our Application Notes.

Notes

Note 1: Maximum capacitive load is defined as the capacitive load that will allow start up in under 1 second without damage to the converter.

ECONOLINE

DC/DC-Converter

with 3 year Warranty

RECOM

1 Watt SIP7 Single Output



EN-60950-1 Certified
UL-60950-1 Certified

RB/E

Derating-Graph (Ambient Temperature)

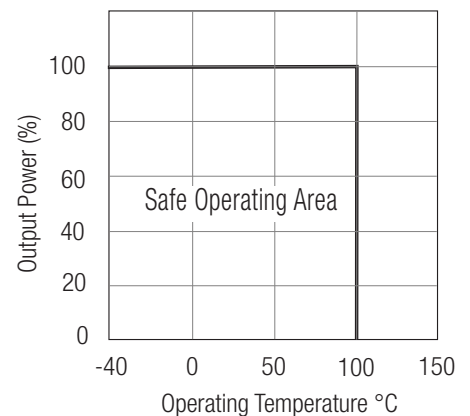

Refer to Application Notes

Typical Characteristics

RB-xx05S/E

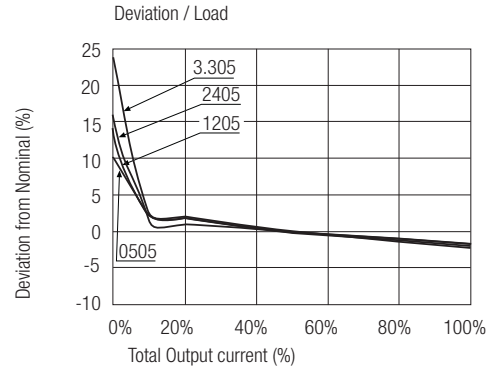
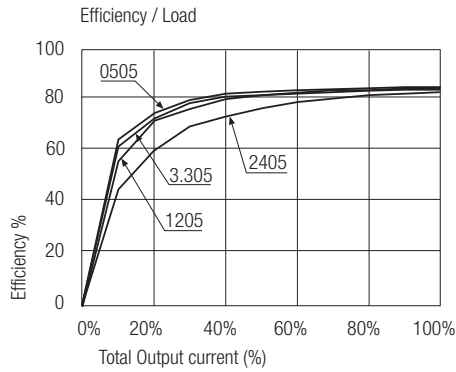

Tolerance Envelope

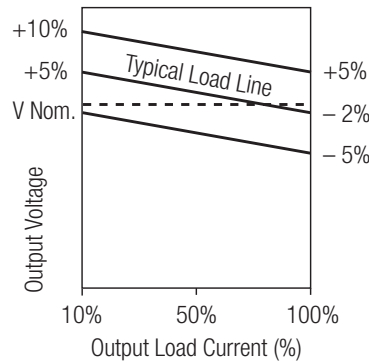

Package Style and Pinning

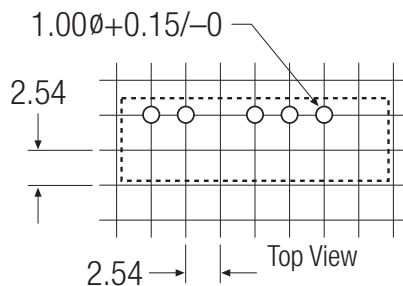
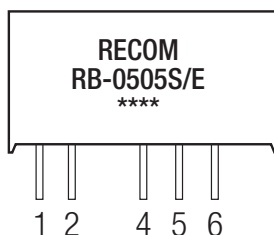
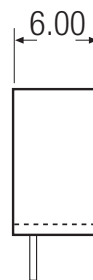
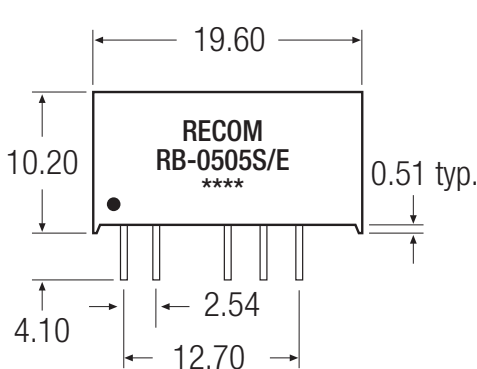

Pin #	Function
1	+Vin
2	-Vin
4	NC
5	-Vout
6	+Vout

NC = No Internal Connection

Unit: mm
Tolerance: ± 0.25 mm

Features

Unregulated Converters

- 1:1 Input Range
- Low Cost 1W Converter
- Efficiency to 76%
- -40°C to +85°C Operating Temperature Range
- UL Certified

Selection Guide

Part Number	Input Voltage (VDC)	Output Voltage (VDC)	Output Current (mA)	Efficiency (typ.)
RBE-0505S	5	5	200	76%

Specifications (measured at $T_A = 25^\circ\text{C}$, nominal input voltage, full load and after warm-up)

Input Voltage Range		$\pm 10\%$ max.	
Output Voltage Accuracy		-2% typ., $\pm 5\%$ max.	
Line Voltage Regulation	(low line to high line at max. load)	1.2% typ.	
	20% to 100% load (5V output)	10% max.	
Output Ripple and Noise (20MHz BW limited)		52mVp-p typ. / 100mVp-p max.	
Operating Frequency (V_{in} =nominal input)		50kHz min. / 82kHz typ. / 105kHz max.	
Efficiency		76% typ. / 70% min.	
Isolation Test Voltage	(tested for 1 second)	1000 VDC min.	
	(rated for 1 minute*)	500VAC / 60Hz	
Isolation Capacitance		75pF max.	
Isolation Resistance	(Viso=500V)	1G Ω min.	
Short-Circuit Protection		1 sec.	
Operating Temperature Range		-40°C to +85°C	
Storage Temperature		-55°C to +125°C	
Relative Humidity		95% RH	
Package Weight		2.2g	
MTBF (+25°C)	} Detailed Information see Application Notes chapter "MTBF"	using MIL-HDBK 217F	2400 x 10 ³ hours
MTBF (+85°C)		using MIL-HDBK 217F	650 x 10 ³ hours
Certification			
UL General Safety	Report: E358085-A4		UL60950-1

*Any data referred to in this datasheet are of indicative nature and based on our practical experience only. For further details, please refer to our Application Notes.

Typical Characteristics

Tolerance Envelope

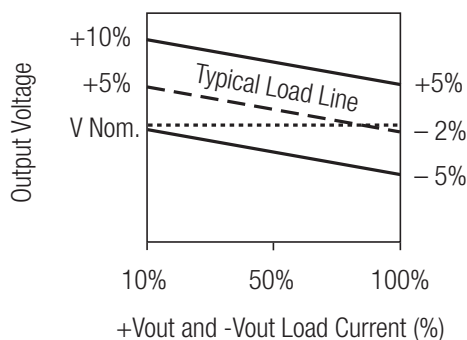

ECONOLINE

DC/DC-Converter

with 3 year Warranty

RECOM

1 Watt SIP7 Single Output



UL-60950-1 Certified

RBE

Derating-Graph (Ambient Temperature)

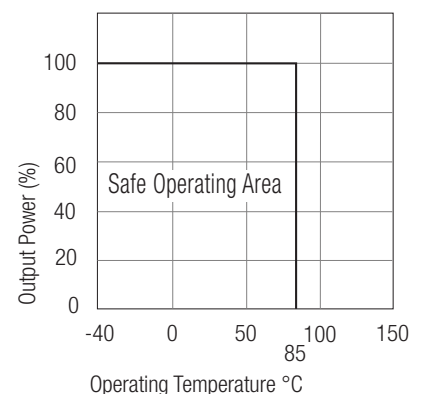

Refer to Application Notes

Typical Characteristics

RBE-0505S

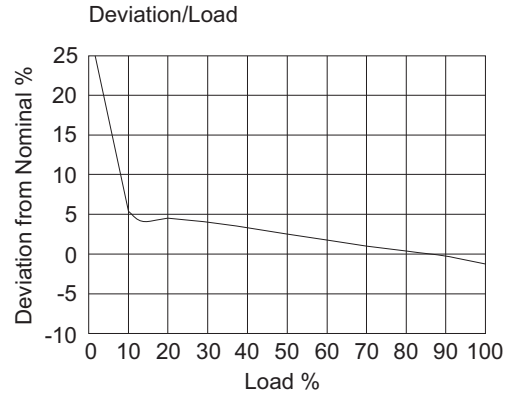
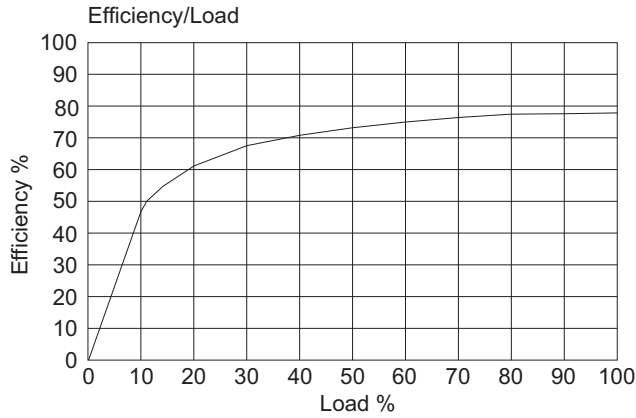

Package Style and Pinning

Single SIP 7PIN Package

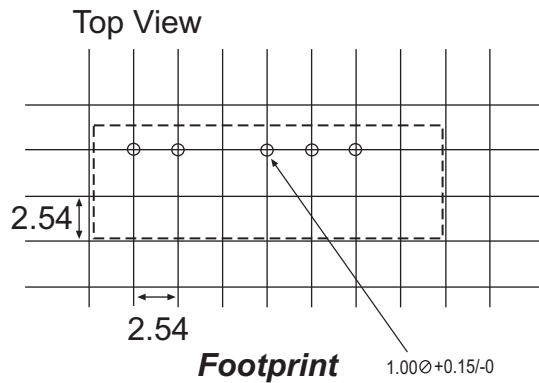
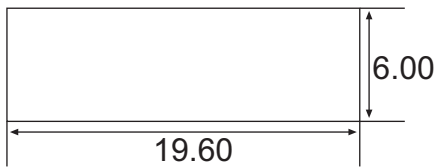

Pin Connections	
Pin #	Function
1	+Vin
2	-Vin
4	NC
5	-Vout
6	+Vout

NC = No Connection
Unit: mm
Tolerance: ± 0.25 mm

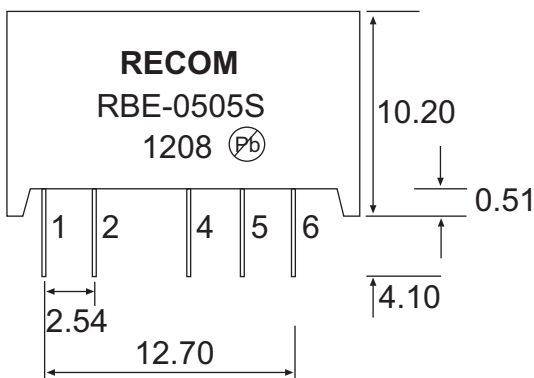

RBE

Features

Unregulated Converter

- Industry Standard Pinout
- 1kVDC or 2kVDC Isolation
- UL94V-0 Package Material
- Optional Continuous Short Circuit Protected
- Fully Encapsulated
- Custom Solutions Available
- Efficiency to 85 %

Description

The RE DC/DC converters are typically used in general purpose power isolation and voltage matching applications, and feature a full industrial operating temperature range of -40°C to +85°C without derating.

Selection Guide

Part Number		Input Voltage (VDC)	Output Voltage (VDC)	Output Current (mA)	Efficiency (%)	Max Capacitive Load ⁽¹⁾
RE-xx3.3S	(H)	3.3, 5, 12, 15, 24	3.3	303	75	2200µF
RE-xx05S	(H)	3.3, 5, 12, 15, 24	5	200	78-80	1000µF
RE-xx09S	(H)	3.3, 5, 12, 15, 24	9	111	78-80	1000µF
RE-xx12S	(H)	3.3, 5, 12, 15, 24	12	83	80-84	470µF
RE-xx15S	(H)	3.3, 5, 12, 15, 24	15	66	80-84	470µF
RE-xx24S	(H)	3.3, 5, 12, 15, 24	24	42	78-85	220µF

xx = Input Voltage (other input and output voltage combinations available on request)

* add Suffix "P" for Continuous Short Circuit Protection, e.g. RE-0505S/P, RE-0505S/HP

Specifications (measured at T_A = 25°C, nominal input voltage, full load and after warm-up)

Input Voltage Range		±10%
Output Voltage Accuracy		±5%
Line Voltage Regulation		1.2%/1% of V _{in} typ.
Load Voltage Regulation (10% to 100% full load)	3.3V output type	20% max.
	5V output type	15% max.
	9V, 12V, 15V, 24V output types	10% max.
Output Ripple and Noise (20MHz limited)		100mVp-p max.
Operating Frequency		50kHz min. / 100kHz typ. / 105kHz max.
Efficiency at Full Load		70% min. / 80% typ.
Minimum Load = 0%		Specifications valid for 10% minimum load only.
Isolation Voltage	(tested for 1 second)	1000VDC
	(rated for 1 minute**)	500VAC / 60Hz
Isolation Voltage	H-Suffix (tested for 1 second)	2000VDC
	H-Suffix (rated for 1 minute**)	1000VAC / 60Hz
Isolation Capacitance		20pF min. / 75pF max.
Isolation Resistance		10 GΩ min.
Short Circuit Protection		1 Second
P-Suffix		Continuous
Operating Temperature Range (free air convection)		-40°C to +85°C (see Graph)
Storage Temperature Range		-55°C to +125°C
Relative Humidity		95% RH
Package Weight		2.2g
Packing Quantity		25 pcs per Tube
MTBF (+25°C)	} Detailed Information see using MIL-HDBK 217F	992 x 10 ³ hours
(+85°C)		} Application Notes chapter "MTBF" using MIL-HDBK 217F

continued on next page

**Any data referred to in this datasheet are of indicative nature and based on our practical experience only. For further details, please refer to our Application Notes.

ECONOLINE

DC/DC-Converter

with 3 year Warranty

RECOM

1 Watt

SIP7

Single Output

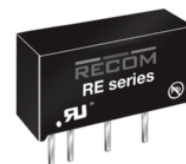

E-358085

EN-60950-1 Certified

UL-60950-1 Certified

RE

Derating-Graph (Ambient Temperature)

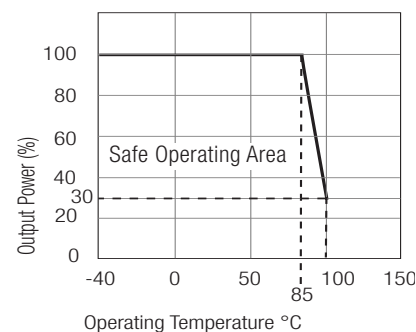

Refer to Application Notes

Specifications (measured at $T_A = 25^\circ\text{C}$, nominal input voltage, full load and after warm-up)

Certifications

CB Test Report Report: US/15348/UL
 UL General Safety Report: E358085
 EN General Safety Report: SPCLVD1109103

IEC 60950-1:2005 2nd Edition
 UL 60950-1 2nd Edition
 EN60950-1:2006 + A12:2011

Notes

Note 1 Maximum capacitive load is defined as the capacitive load that will allow start up in under 1 second without damage to the converter.

Typical Characteristics

RE-xx05S

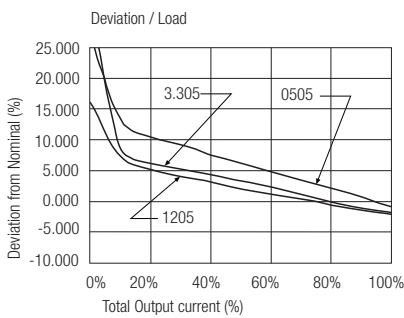
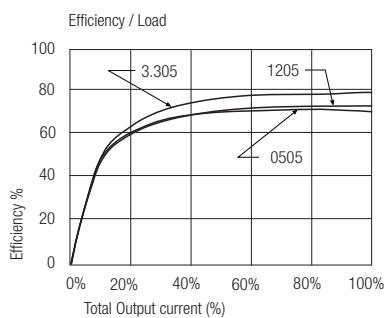

RE-xx12S

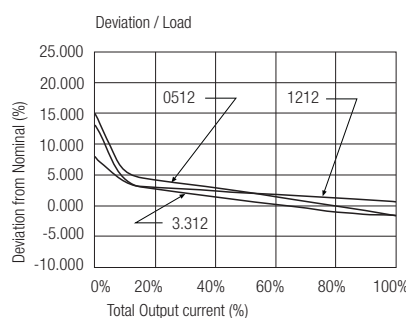
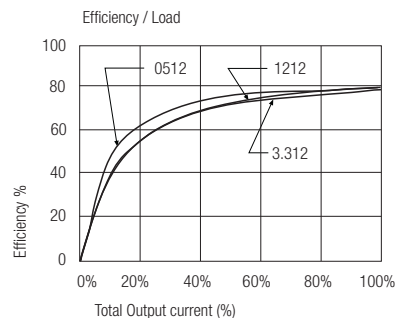

RE-xx15S

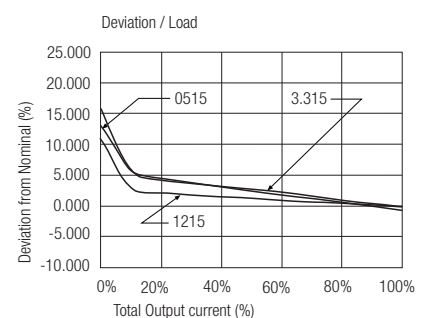
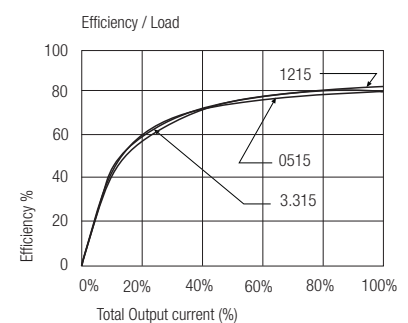

Package Style and Pinning (mm)

7 PIN SIP Package

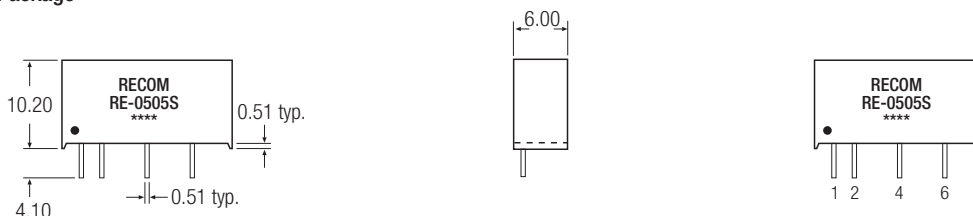

Recommended Footprint Details

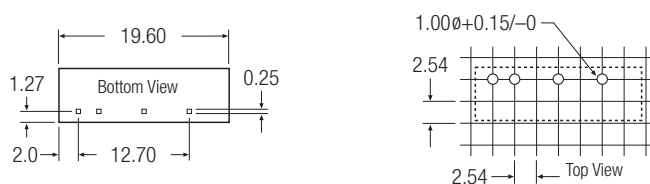

RE Pin Connections

Pin #	Single
1	+Vin
2	-Vin
4	-Vout
6	+Vout
XX.X	± 0.5 mm
XX.XX	± 0.25 mm

The product information and specifications are subject to change without prior notice. All products are designed for non-safety critical commercial and industrial applications. The Buyer agrees to implement safeguards that anticipate the consequences of any failures that might cause harm, loss of life and/or damage property.

Features

Unregulated Converters

- 1:1 Input Range
- Low Cost 1W Converter
- Efficiency to 76%
- -40°C to +85°C Operating Temperature Range
- UL Certified

Selection Guide

Part Number SMD	Input Voltage (VDC)	Output Voltage (VDC)	Output Current (mA)	Efficiency (typ.)
REE-0505S	5	5	200	76%

Specifications (measured at $T_A = 25^\circ\text{C}$, nominal input voltage, full load and after warm-up)

Input Voltage Range		$\pm 10\%$ max.	
Output Voltage Accuracy		-2% typ., $\pm 5\%$ max.	
Line Voltage Regulation	(low line to high line at max. load)	1.2% typ.	
	20% to 100% load (5V output)	10% max.	
Output Ripple and Noise (20MHz BW limited)		55mVp-p typ. / 100mVp-p max.	
Operating Frequency (V_{in} =nominal input)		50kHz min. / 82kHz typ. / 105kHz max.	
Efficiency		76% typ. / 70% min.	
Isolation Test Voltage	(tested for 1 second)	1000 VDC min.	
	(rated for 1 minute*)	500VAC / 60Hz	
Isolation Capacitance		75pF max.	
Isolation Resistance	(Viso=500V)	1G Ω min.	
Short-Circuit Protection		1 sec.	
Operating Temperature Range		-40°C to +85°C	
Storage Temperature		-55°C to +125°C	
Relative Humidity		95% RH	
Package Weight		2.2g	
MTBF (+25°C)	} Detailed Information see Application Notes chapter "MTBF"	using MIL-HDBK 217F	2400 x 10 ³ hours
MTBF (+85°C)		using MIL-HDBK 217F	650 x 10 ³ hours

Certification

UL General Safety Report: E358085-A4 UL60950-1

*Any data referred to in this datasheet are of indicative nature and based on our practical experience only. For further details, please refer to our Application Notes.

Typical Characteristics

Tolerance Envelope

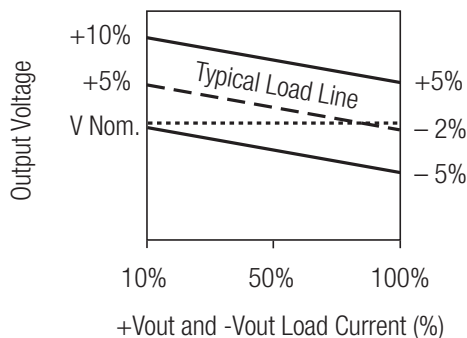

ECONOLINE

DC/DC-Converter

with 3 year Warranty

RECOM

1 Watt SIP7 Single Output



UL-60950-1 Certified

REE

Derating-Graph (Ambient Temperature)

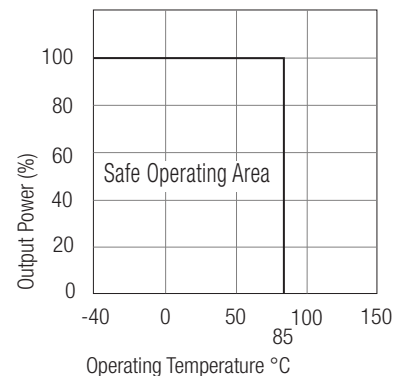

Refer to Application Notes

Typical Characteristics

REE-0505S

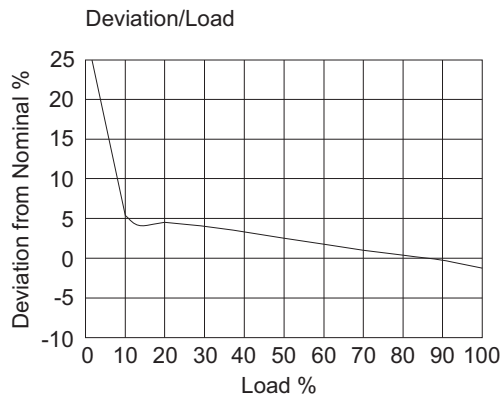
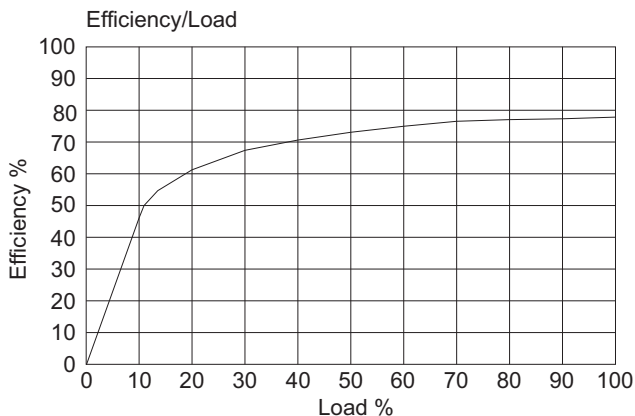

Package Style and Pinning

Single SIP 7PIN Package

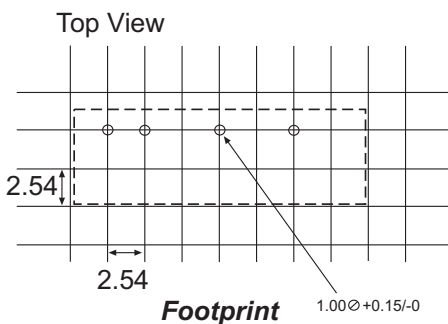
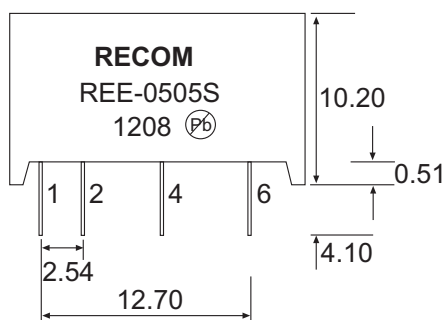

Pin Connections

Pin #	Function
1	+Vin
2	-Vin
4	-Vout
6	+Vout

Unit: mm
Tolerance: ± 0.25 mm

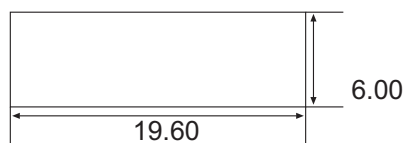
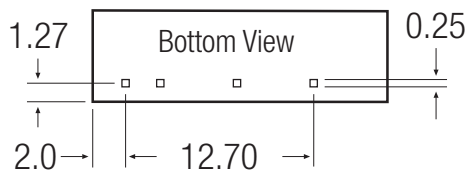

Features

Unregulated Converter

- 3kVDC or 4kVDC Isolation
- Optional Continuous Short Circuit Protected
- Custom Solutions Available
- UL94V-0 Package Material
- Efficiency to 84 %
- Suitable for IGBT Applications

Description

The RK and RH Series DC/DC-Converter complements Recom's industrial range of converters with very high isolations of 3KV and 4kVDC. The extended operating temperature range covering -40°C to +90°C is a standard feature. The converters are EN-60601-1 certified, making them suitable for medical as well as IGBT driver applications.

Selection Guide

Part Number	(4kV)	Input Voltage (VDC)	Output Voltage (VDC)	Output Current (mA)	Efficiency (%)	Max Capacitive Load ⁽¹⁾
RK-xx05S*	(H)	5, 12, 15, 24	5	200	70-78	1000µF
RK-xx09S*	(H)	5, 12, 15, 24	9	111	70-80	1000µF
RK-xx12S*	(H)	5, 12, 15, 24	12	84	78-82	470µF
RK-xx15S*	(H)	5, 12, 15, 24	15	66	80-82	470µF
RH-xx05D*	(H)	5, 12, 15, 24	±5	±100	74-78	±470µF
RH-xx09D*	(H)	5, 12, 15, 24	±9	±56	76-79	±470µF
RH-xx12D*	(H)	5, 12, 15, 24	±12	±42	78-84	±220µF
RH-xx15D*	(H)	5, 12, 15, 24	±15	±33	80-84	±220µF
RH-xx1509D*	(H)	5, 12, 24	+15/-9	+33/-56	70-81	+220/-470µF

xx = Input Voltage. Other input and output voltage combinations available on request.

* add Suffix "P" for Continuous Short Circuit Protection, e.g. RK-0505S/P, RK-0505S/HP

Specifications (measured at T_A = 25°C, nominal input voltage, full load and after warm-up)

Input Voltage Range		±10%
Output Voltage Accuracy		±5%
Line Voltage Regulation		1.2%/1% of Vin typ.
Load Voltage Regulation (10% to 100% full load)	5V output type	15% max.
	9V, 12V, 15V, 24V output types	10% max.
	RH-xx1509D	10% max.
Output Ripple and Noise (20MHz limited)	Single output types	100mVp-p max.
	Dual output types	±75mVp-p max.
Operating Frequency	RK types	50kHz min. / 100kHz typ. / 105kHz max.
	RH types	57kHz min. / 100kHz typ. / 105kHz max.
	RK-xx1509D	50kHz min. / 88kHz typ.
Efficiency at Full Load		70% min. / 80% typ.
Minimum Load = 0%		Specifications valid for 10% minimum load only.
Isolation Voltage	(tested for 1 second)	3000VDC
	(rated for 1 minute***)	1500VAC / 60Hz
Isolation Voltage	H-Suffix (tested for 1 second)	4000VDC
	H-Suffix (rated for 1 minute***)	2000VAC / 60Hz
Isolation Capacitance	RK types	20pF min. / 75pF max.
	RH types	20pF min. / 65pF max.
Isolation Resistance		15 GΩ min.
Short Circuit Protection		1 Second
P-Suffix		Continuous
Operating Temperature Range (free air convection, without derating)		-40°C to +90°C (see Graph)
Storage Temperature Range		-55°C to +125°C
Relative Humidity		95% RH

continued on next page

ECONOLINE

DC/DC-Converter

with 3 year Warranty

RECOM

1 Watt

SIP7

Single & Dual Output

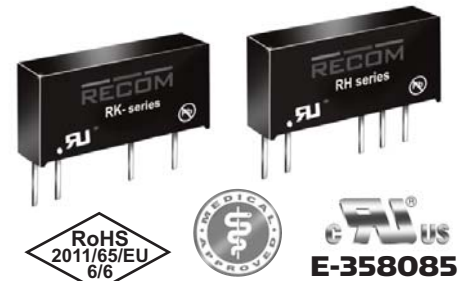

EN-60950-1 Certified
IEC/EN-60601-1 Certified**
UL-60950-1 Certified**
**** +15/-9 Version excluded**

RK_RH

Derating-Graph (Ambient Temperature)

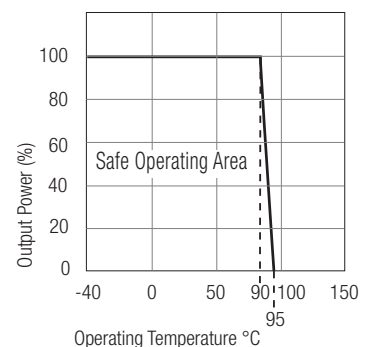

***Any data referred to in this datasheet are of indicative nature and based on our practical experience only. For further details, please refer to our Application Notes.

Refer to Application Notes

Specifications (measured at $T_A = 25^\circ\text{C}$, nominal input voltage, full load and after warm-up)

Package Weight		2.6g	
H-Suffix		2.8g	
Packing Quantity		25 pcs per Tube	
MTBF (+25°C)	} Detailed Information see Application Notes chapter "MTBF"	RK types	992 x 10 ³ hours
(+85°C)		RH types	1012 x 10 ³ hours
using MIL-HDBK 217F		RK types	145 x 10 ³ hours
		RH types	151 x 10 ³ hours
Certifications			
EN General Safety	Report: SPCLVD1109103		EN60950-1: 2006 + A12:2011
EN Medical Safety	Report: SPCMDD1205098-4		IEC/EN 60601-1: 2006, 3rd Edition
UL General Safety	Report: E358085		UL60950-1, 2nd Edition

Typical Characteristics

RK-xx05S

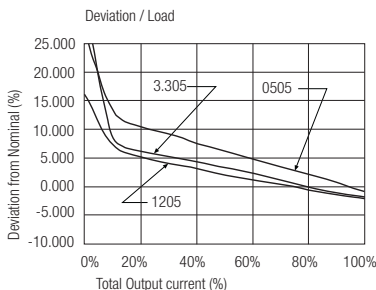
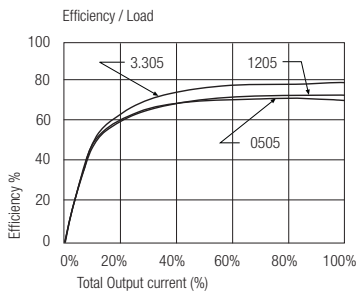

RK-xx09S

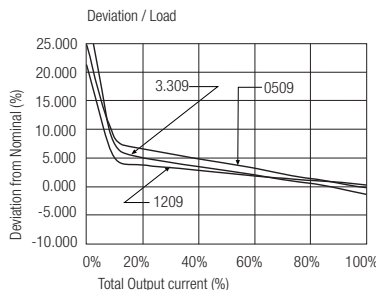
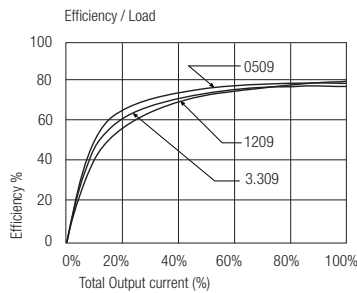

RK-xx12S

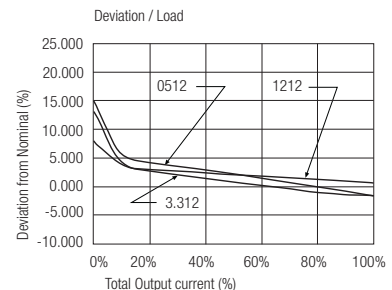
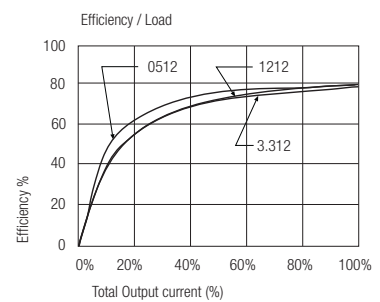

RK-xx15S

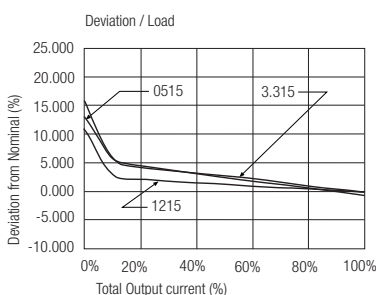
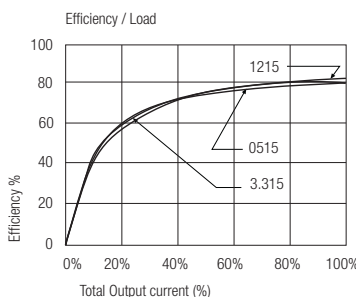

RH-xx05D

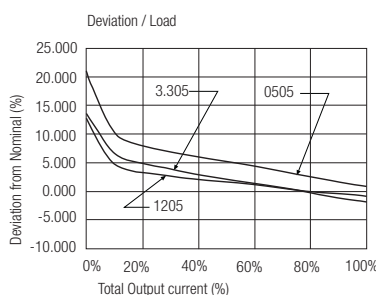
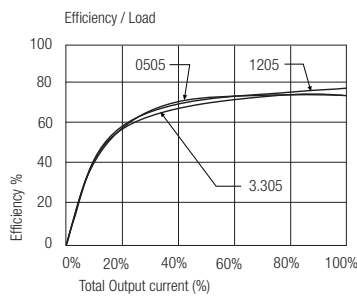

RH-xx09D

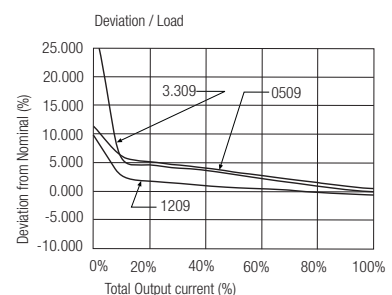
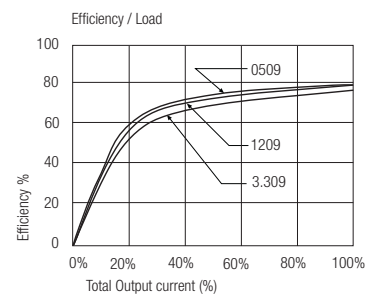

Typical Characteristics

RH-xx12D

RH-xx15D

IGBT Application Circuit

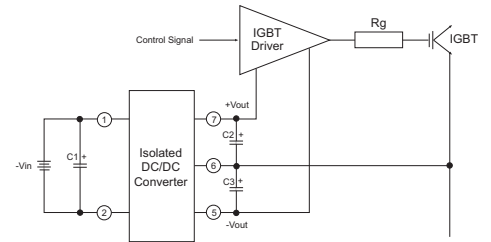
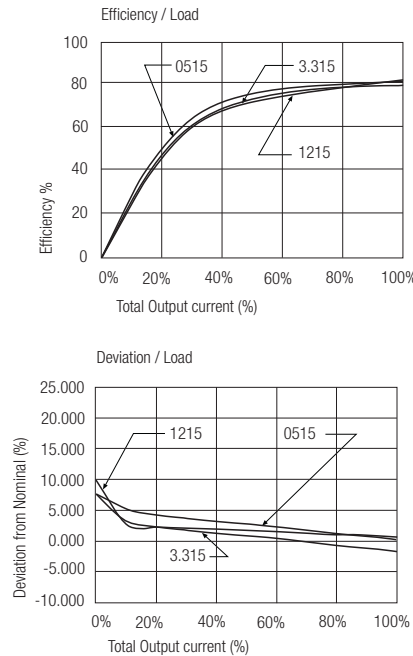
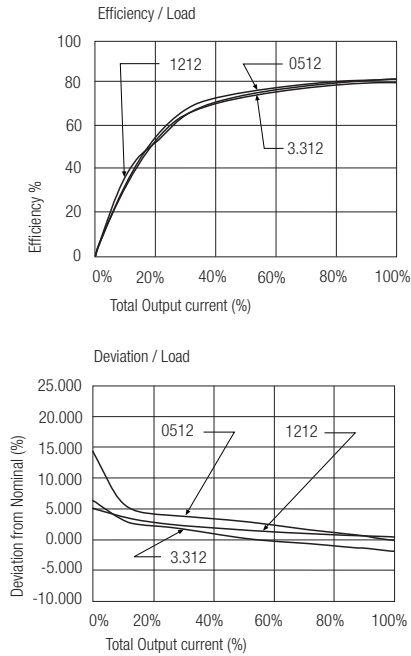

Notes
Note 1 Maximum capacitive load is defined as the capacitive load that will allow start up in under 1 second without damage to the converter.

Package Style and Pinning (mm)

RK_RH

7 PIN SIP Package

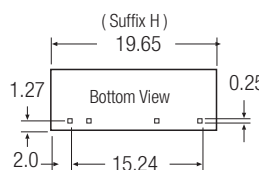
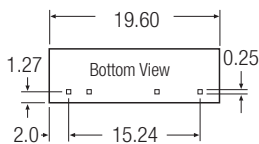
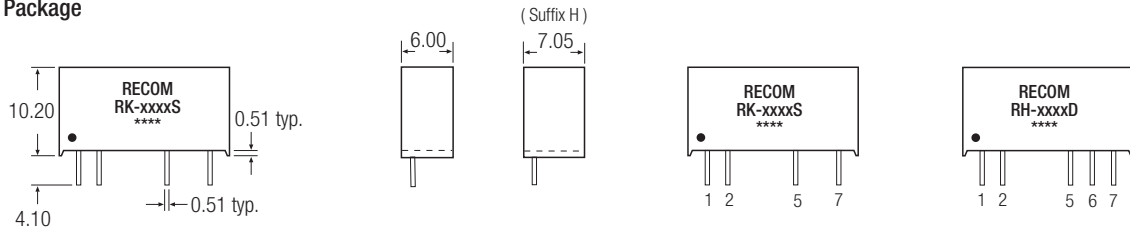

Recommended Footprint Details

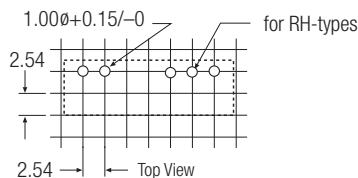

Recommended Footprint Details

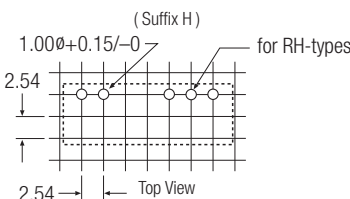

Pin Connections
RK-xxxxS

Pin #	Single
1	+Vin
2	-Vin
5	-Vout
7	+Vout

Pin Connections
RH-xxxxD

Pin #	Dual
1	+Vin
2	-Vin
5	-Vout
6	Com
7	+Vout

XX.X ± 0.5 mm
XX.XX ± 0.25 mm

The product information and specifications are subject to change without prior notice. All products are designed for non-safety critical commercial and industrial applications. The Buyer agrees to implement safeguards that anticipate the consequences of any failures that might cause harm, loss of life and/or damage property.

Features

Unregulated Converter

- Low Cost 1W Converter
- 4kVDC / 1 sec High Isolation
- Low Output Ripple
- Wide Operating Temperature Range of -40°C to +85°C
- Industry Standard Pinout
- UL Certified

Selection Guide

Part Number	Input Voltage (VDC)	Output Voltage (VDC)	Output Current (mA)	Efficiency (%)	Max Capacitive Load ⁽¹⁾
SIP 7					
RKE-0505S/H	5	5	200	70	1200µf

Specifications (measured at T_A = 25°C, nominal input voltage, full load and after warm-up)

Input Voltage Range			±10%
Output Voltage Accuracy			-2% typ. / ±5% max.
Efficiency (@ Full Load)			65% min. / 70% typ.
Operating Frequency			50kHz min / 65kHz typ. / 105kHz
Output Ripple & Noise			55mVp-p typ. / 100mVp-p max.
Line Voltage Regulation	Low Line to High Line @ max. Load		1.2% typ. of 1% Vin
Load Voltage Regulation	(10% to 100% Load)		12% typ. / 15% max.
Isolation Voltage	(tested for 1 minute)		3kVDC
	(rated for 1 second*)		4kVDC
Isolation Capacitance			75pF max.
Isolation Resistance	Viso=500V		1GΩ min.
Short Circuit Protection			1 sec.
Operating Temperature Range			-40°C to +85°C
Storage Temperature Range			-55°C to 125°C
Humidity			95% max.
Size			19.60mm x 10.20mm x 7.05mm
Weight			2.7g
MTBF (25°C)	using MIL-HDBK 217F		850 x 10 ³ hours
	using MIL-HDBK 217F		123 x 10 ³ hours
Certification			
UL General Safety	Report: E358085-A4		UL60950-1

*Any data referred to in this datasheet are of indicative nature and based on our practical experience only. For further details, please refer to our Application Notes.

Notes

Note1: Maximum capacitive load is defined as the capacitive load that will allow start up in under 1second without damage to the converter.

Tolerance Envelopes

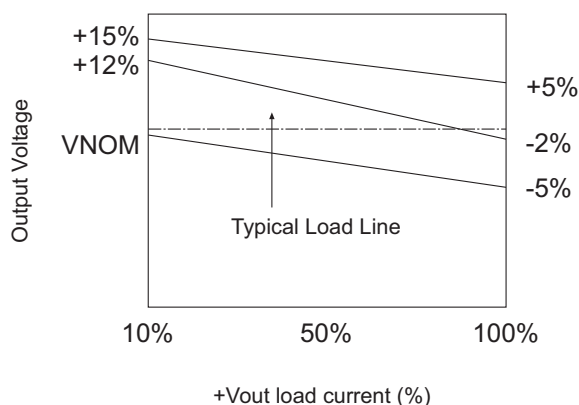

ECONOLINE

DC/DC-Converter

with 3 year Warranty

RECOM

1 Watt SIP7 Single Output



UL-60950-1 Certified

RKE-0505S/H

Derating-Graph (Ambient Temperature)

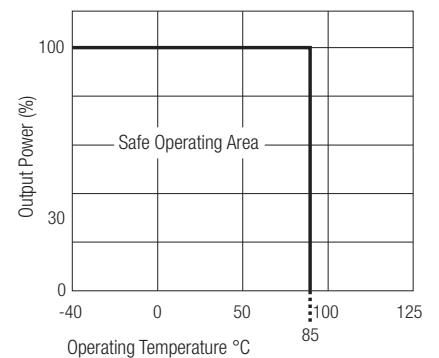

Refer to Application Notes

Typical Characteristics

Efficiency vs Load

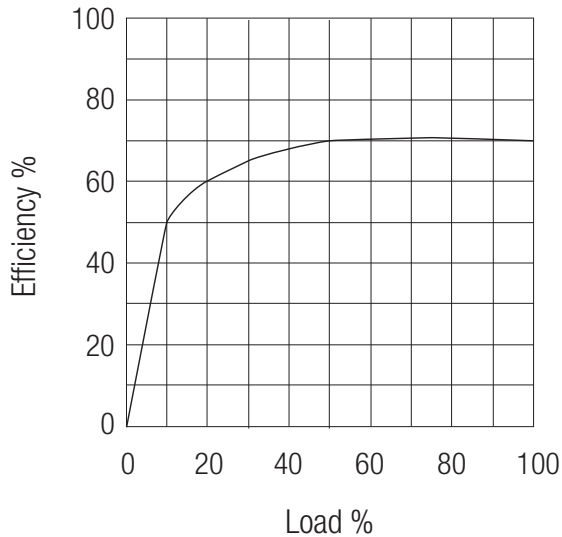

Deviation vs Load

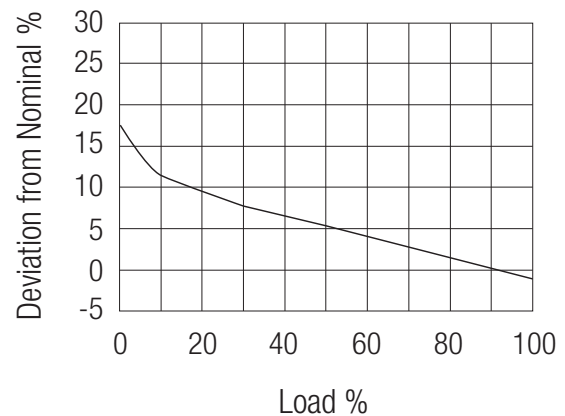

Package Style and Pinning (mm)

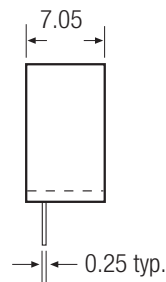
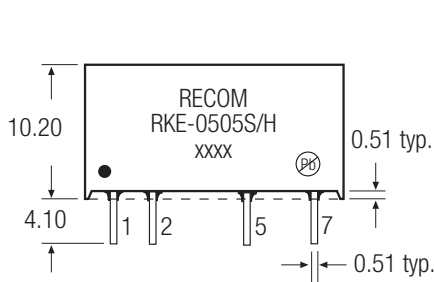

Pin Connections RKE-0505S/H

Pin #	Single
1	+Vin
2	-Vin
5	-Vout
7	+Vout

XX.X ± 0.5 mm
XX.XX ± 0.25 mm

Recommended Footprint Details

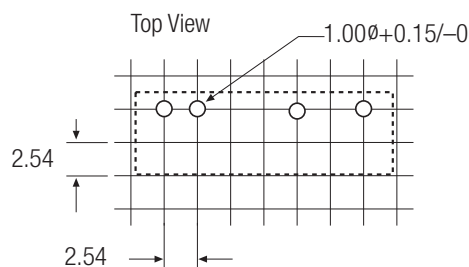
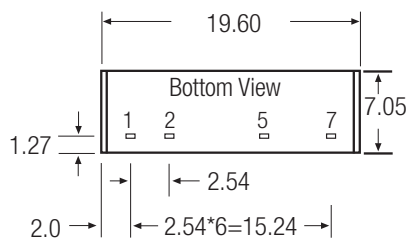

Features

Unregulated Converters

- 1:1 Input Range
- Efficiency up to 80%
- 3kVDC and 4kVDC Isolation Option
- Approved for Medical Applications
- -40°C to +100°C Operating Temperature Range
- Continuous Short Circuit Protection

Selection Guide

Part Number	Isolation Voltage (kV)	Input Voltage (VDC)	Output Voltage (VDC)	Output Current (mA)	Efficiency (typ.)	Capacitive Load (max.)
RAM-0505S*	3	5	5	200	78%	1000µF
RAM-1205S*	3	12	5	200	80%	1000µF
RAM-2405S*	3	24	5	200	80%	1000µF

* add Suffix "/H" for Isolation 4kVDC/1min. e.g. RAM-0505S/H

* add Suffix "-R" for tape&reel packing e.g. RAM-1205S-R or RAM-2405S/H-R

Specifications (measured at T_A = 25°C, nominal input voltage and rated output current unless otherwise specified)

Input Voltage Range			±10%
Output Voltage Accuracy			-1% typ., ±5% max.
Line Voltage Regulation	(low line to high line at max. load)	1.2% typ., 1.5% max.	
Load Voltage Regulation	(10% to 100% full load)	10% typ., 15% max.	
Output Ripple and Noise (20MHz BW limited)			50mVp-p typ., 100mVp-p max.
Operating Frequency (Vin=nominal input)			20kHz min. / 50kHz typ. / 90kHz max.
Efficiency			see Selection Guide
Minimum Load = 0%	Specifications valid for 10% minimum load only		
Isolation Voltage	(tested for 1 second)		3750 VDC
	(rated for 1 minute**)		3000 VDC
Isolation Voltage	H-Suffix	(tested for 1 second)	5000 VDC
	H-Suffix	(rated for 1 minute**)	4000 VDC
Isolation Capacitance			4pF typ., 10pF max.
Isolation Resistance	(Viso=500V)	15GΩ min.	
Short-Circuit Protection			continuous
Operating Temperature Range			-40°C to +100°C
Storage Temperature			-55°C to +125°C
Reflow Temperature	RoHS compliant	245°C (30 sec.), Peak 255°C (5sec.) max.	
Vapour Phase Process	(for more details see Application Notes)	230°C (90 sec.) max.	
Relative Humidity			95% RH
Package Weight			1.3g
Packing Quantity	All Types		27 pcs per Tube
	All Types		500 pcs per Reel
MTBF (+25°C)	} Detailed Information see Application Notes chapter "MTBF"	using MIL-HDBK 217F	4780 x 10 ³ hours
MTBF (+85°C)		using MIL-HDBK 217F	1310 x 10 ³ hours

Certifications

EN Medical Safety	Report: MDD1112018 + RM1112018	IEC/EN 60601-1 3rd Edition
	Medical Report + ISO14971 Risk Assessment	
EN General Safety	Report: SPCLVD1112018	EN60950-1, 2nd Edition

**Any data referred to in this datasheet are of indicative nature and based on our practical experience only. For further details, please refer to our Application Notes.

ECONOLINE

DC/DC-Converter

RECOM

1 Watt SMD Single Output



EN-60601-1 Certified
EN-60950-1 Certified

RAM

Derating-Graph (Ambient Temperature)

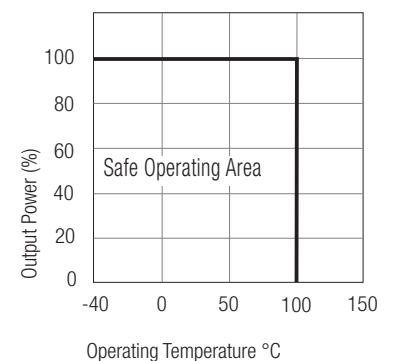

Refer to Application Notes

Typical Characteristics

Tolerance Envelope

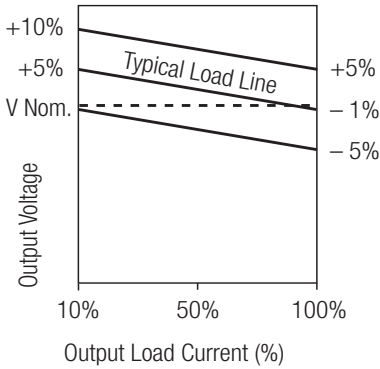

RAM-xx05S

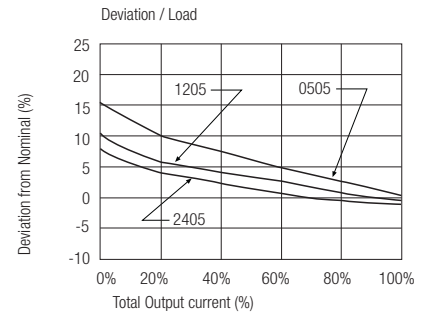
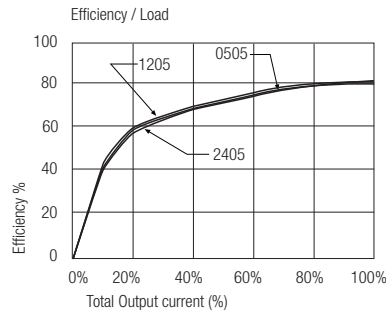

Notes

Note 1: Maximum capacitive load is defined as the capacitive load that will allow start up in under 1 second without damage to the converter

Package Style and Pinning

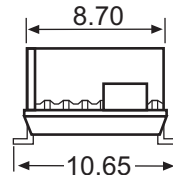
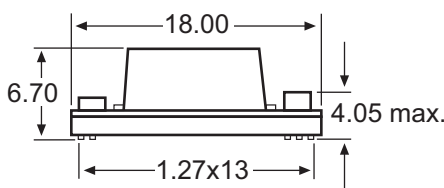

Recommended Footprint Details

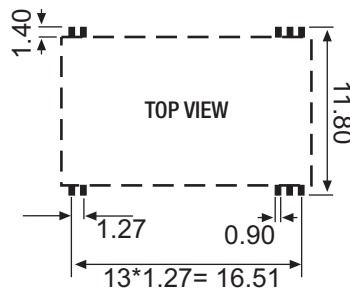
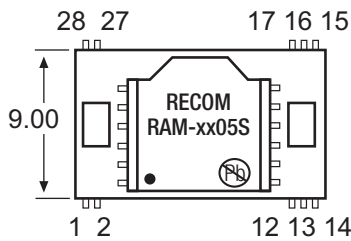

Pin Connections

Pin #	Function
1	+Vin
2	-Vin
12	-Vout
13	+Vout
14~17	NC
27,28	NC

NC = No Connection

Unit: mm
Tolerance: ± 0.25 mm

EMC Filtering - Suggestion for EN55022 Class B

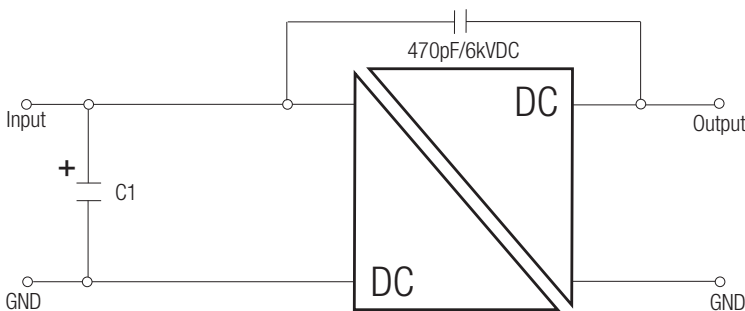

Input Voltage	Inductance/ Capacitance (C1)
5V	10µF
12V	4.7µF
24V	22µF

The product information and specifications are subject to change without prior notice. All products are designed for non-safety critical commercial and industrial applications. The Buyer agrees to implement safeguards that anticipate the consequences of any failures that might cause harm, loss of life and/or damage property.

Features

Regulated Converters

- 1:1 Input Range
- Efficiency up to 69%
- 1kVDC and 2kVDC Isolation Option
- 1W SMD Package
- -40°C to +85°C Operating Temperature Range
- Continuous Short Circuit Protection

ECONOLINE
DC/DC-Converter

RECOM

Selection Guide

Part Number SMD	Input Voltage (VDC)	Output Voltage (VDC)	Output Current (mA)	Efficiency (typ.)	Capacitive Load (max.)
RAZ-0505S*	5	5	200	67%	2200µF
RAZ-1205S*	12	5	200	68%	2200µF
RAZ-2405S*	24	5	200	69%	2200µF

* add Suffix "/H" for 2kVDC/1min. Isolation - e.g. RAZ-0505S/H

* add Suffix "-R" for tape & reel packing - e.g. RAZ-1205S-R, RAZ-2405S/H-R

Specifications (measured at $T_A = 25^\circ\text{C}$, nominal input voltage and rated output current unless otherwise specified)

Input Voltage Range		$\pm 10\%$ max.	
Output Voltage Accuracy		-1% typ., $\pm 5\%$ max.	
Line Voltage Regulation	(low line to high line at max. load)	1% max.	
Load Voltage Regulation	(10% to 100% full load)	1% max.	
Output Ripple and Noise (20MHz BW)		50mVp-p typ., 75mVp-p max.	
Operating Frequency (V_{in} =nominal input)		20kHz min. / 35kHz typ. / 60kHz max.	
Efficiency at Full Load		see Selection Guide	
Minimum Load = 0%		Specifications valid for 10% minimum load only	
Isolation Voltage	(tested for 1 second)	1250 VDC	
	(rated for 1 minute**)	1000 VDC	
Isolation Voltage	H-Suffix (tested for 1 second)	2500 VDC	
	H-Suffix (rated for 1 minute**)	2000 VDC	
Isolation Capacitance		6pF typ., 10pF max.	
Isolation Resistance	($V_{iso}=500V$)	10GΩ min.	
Short-Circuit Protection		continuous	
Operating Temperature Range		-40°C to +85°C	
Storage Temperature		-55°C to +125°C	
Relative Humidity		95% RH	
Package Weight		1.6g	
MTBF (+25°C)	} Detailed Information see Application Notes chapter "MTBF"	using MIL-HDBK 217F	3914 x 10 ³ hours
MTBF (+85°C)		using MIL-HDBK 217F	855 x 10 ³ hours

Certifications

EN General Safety	Report: SPCLVD1112018	EN60950-1, 2nd Edition
EN Medical Safety	Report: MDD1112018 + RM1112018 Medical Report + ISO14971 Risk Assessment	IEC/EN 60601-1 3rd Edition

**Any data referred to in this datasheet are of indicative nature and based on our practical experience only. For further details, please refer to our Application Notes.

1 Watt SMD Single Output



EN-60950-1 Certified
EN-60601-1 Certified*
(* /H suffix)

RAZ

Derating-Graph (Ambient Temperature)

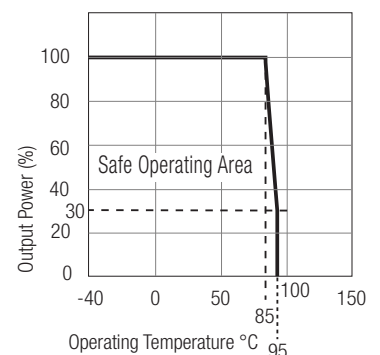

Refer to Application Notes

Typical Characteristics

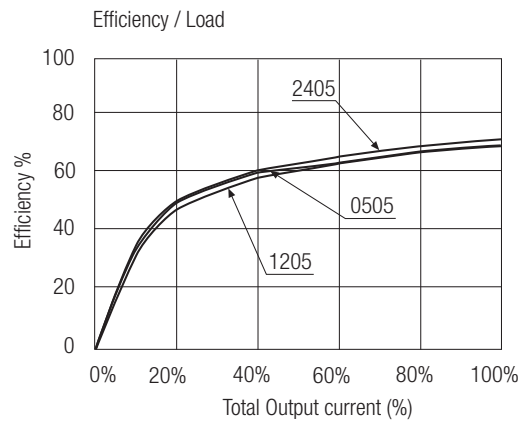

Note

Note 1: Maximum capacitive load is defined as the capacitive load that will allow start up in under 1 second without damage to the converter.

Package Style and Pinning

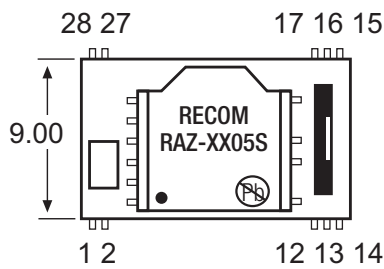
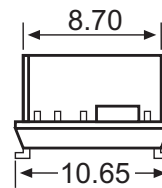
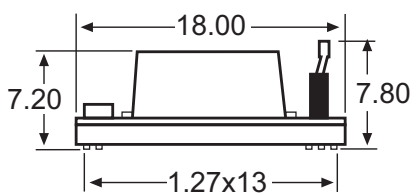

Recommended Footprint Details

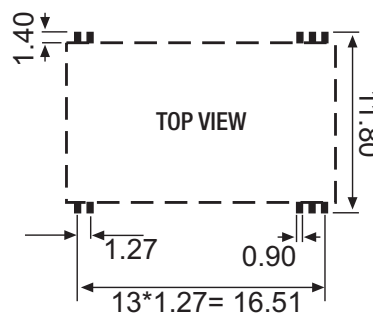

Pin Connections

Pin #	Function
1,2	+Vin
12,15~17,28	NC
13	-Vout
14	+Vout
27	-Vin

NC = No Connection

Unit: mm
Tolerance: ± 0.25 mm

Features

Unregulated Converters

- Pot-Core Transformer - separated windings
- High 5.2kVDC Isolation in compact size
- Optional Continuous Short Circuit Protected
- Pin Compatible with RH and RK Series
- Approved for Medical and IGBT Applications
- UL and EN Certified
- Efficiency to 82 %

Description

The RP series has very high isolation of 5.2 kVDC in a compact size. The converters are EN-60601-1 certified, making them suitable for medical as well as IGBT driver applications.

The /X2 version has rearranged pins to permit an input output separation of more than 9mm.

Selection Guide

Part Number SIP 7	Input Voltage (VDC)	Output Voltage (VDC)	Output Current (mA)	Efficiency (%)	Max Capacitive Load ⁽¹⁾
RP-xx3.3S*	5, 9, 12, 15, 24	3.3	303	70	2200µF
RP-xx05S*	5, 9, 12, 15, 24	5	200	70-72	1000µF
RP-xx09S*	5, 9, 12, 15, 24	9	111	75	1000µF
RP-xx12S*	5, 9, 12, 15, 24	12	84	75-78	470µF
RP-xx15S*	5, 9, 12, 15, 24	15	66	80	470µF
RP-xx24S*	5, 9, 12, 15, 24	24	42	80	220µF
RP-xx3.3D*	5, 9, 12, 15, 24	±3.3	±152	70	±1000µF
RP-xx05D*	5, 9, 12, 15, 24	±5	±100	74-76	±470µF
RP-xx09D*	5, 9, 12, 15, 24	±9	±56	75	±470µF
RP-xx12D*	5, 9, 12, 15, 24	±12	±42	79-82	±220µF
RP-xx15D*	5, 9, 12, 15, 24	±15	±33	80-82	±220µF
RP-xx24D*	5, 9, 12, 15, 24	±24	±21	80	±100µF
RP-xx1509D	5, 12, 24	+15/-9	±42	70-85	±220µF

xx = Input Voltage. Other input and output voltage combinations available on request

* add Suffix "P" for Continuous Short Circuit Protection, e.g. RP-0505S/P, RP-0505D/P

* add Suffix "/X2" for single output with alternative pinning e.g. RP-0505S/X2, RP-0505S/P/X2

Specifications (measured at $T_A = 25^\circ\text{C}$, nominal input voltage, full load and after warm-up)

Input Voltage Range	±10%	
Output Voltage Accuracy	±5%	
Line Voltage Regulation	1.2%/1% of V_{in} typ.	
Load Voltage Regulation	3.3V output types	20% max.
(10% to 100% full load)	5V output type	15% max.
	9V, 12V, 15V, 24V output types, RP-xx1509D	10% max.
Output Ripple and Noise (20MHz limited)	100mVp-p max.	
Operating Frequency	50kHz min. / 100kHz typ. / 120kHz max.	
	RP-xx1509D	50kHz min / 94kHz typ.
Efficiency at Full Load	70% min. / 80% typ.	
Minimum Load = 0%	Specifications valid for 10% minimum load only.	
Isolation Voltage	(tested for 1 second)	5200VDC
	(rated for 1 minute**)	2600VAC / 60Hz
Isolation Capacitance	4pF min. / 10pF max.	
Isolation Resistance	20 GΩ min.	
Short Circuit Protection	1 Second	
P-Suffix	Continuous	
Operating Temperature Range (free air convection, without derating)	-40°C to +90°C (see Graph)	

continued on next page

ECONOLINE

DC/DC-Converter

with 3 year Warranty

RECOM

1 Watt

SIP 7 Single & Dual Output

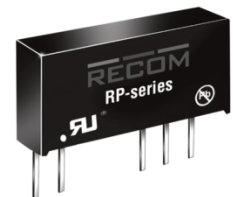

EN-60950-1 Certified
IEC/EN-60601-1 Certified*
CSA/UL-60950-1 Certified*
 * +15/-9 Version excluded

RP

Derating-Graph

(Ambient Temperature)

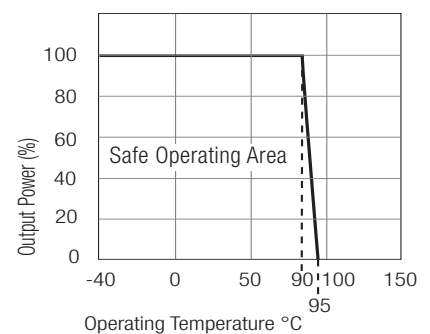

**Any data referred to in this datasheet are of indicative nature and based on our practical experience only. For further details, please refer to our Application Notes.

Refer to Application Notes

Specifications (measured at $T_A = 25^\circ\text{C}$, nominal input voltage, full load and after warm-up)

Storage Temperature Range			-55°C to +125°C
Relative Humidity			95% RH
Package Weight			2.4g
Packing Quantity			25 pcs per Tube
MTBF (+25°C)	} Detailed Information see Application Notes chapter "MTBF"	using MIL-HDBK 217F	928 x 10 ³ hours
(+85°C)		using MIL-HDBK 217F	150 x 10 ³ hours
Certifications			
CSA General Safety	Report: E358085		CSA C22.2 No. 60950-1-03
UL General Safety	Report: E358085		UL 60950-1 2nd Ed.
EN General Safety	Report: SPCLVD1109103		EN60950-1:2006 + A12:2011
EN Medical safety	Report: SPCMD1205098-4		IEC/EN60601-1:2006, 3rd Edition

Notes

Note 1 Maximum capacitive load is defined as the capacitive load that will allow start up in under 1 second without damage to the converter.

Typical Characteristics

RP-xx05S

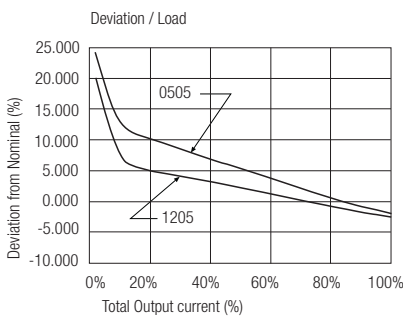
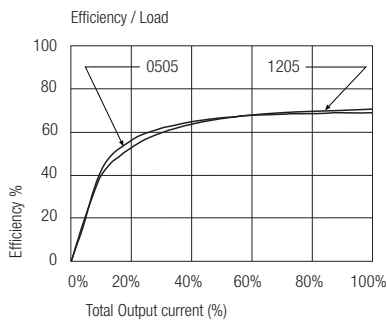

RP-xx05D

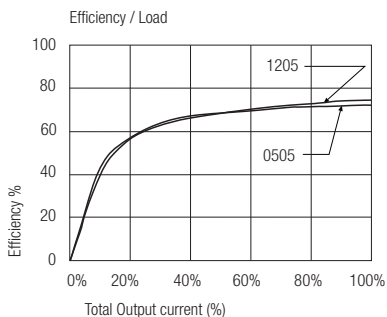

RP-xx12S

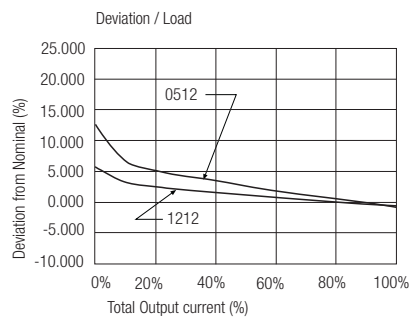
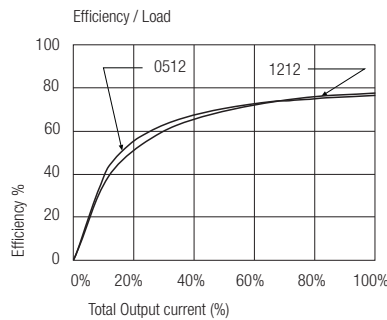

RP-xx12D

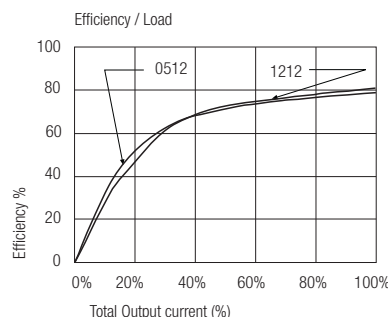

RP-xx15S

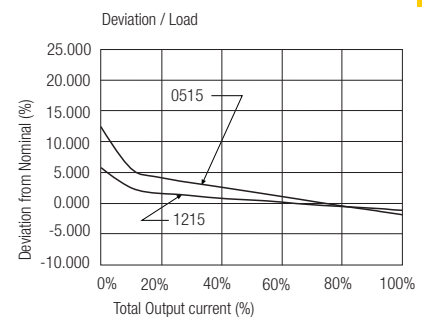
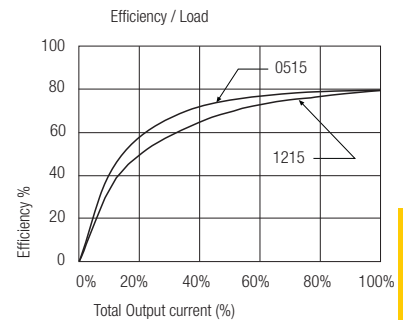

RP-xx15D

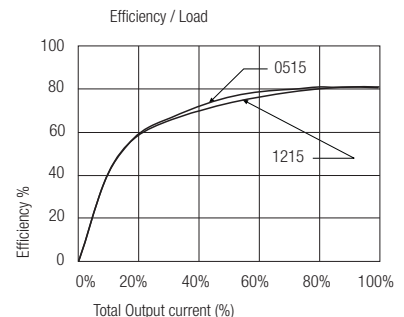

continued on next page

Typical Characteristics

RP-xx05D

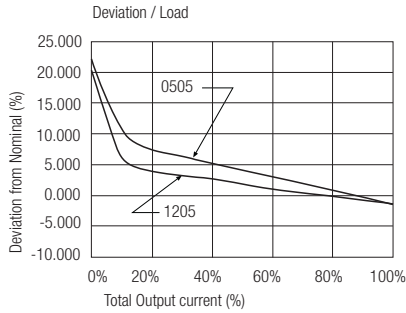

RP-xx12D

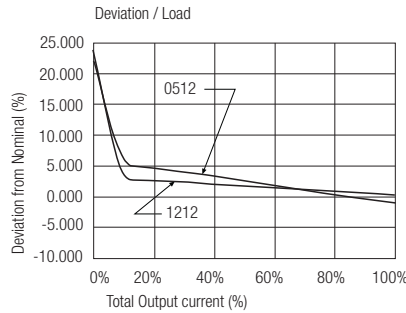

RP-xx15D

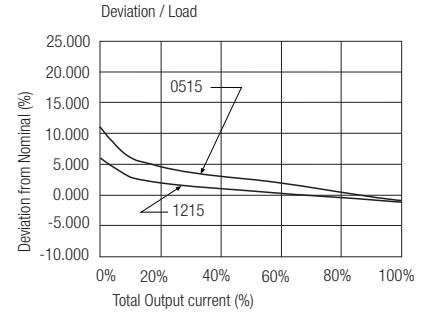

Application

IGBT Application Circuit

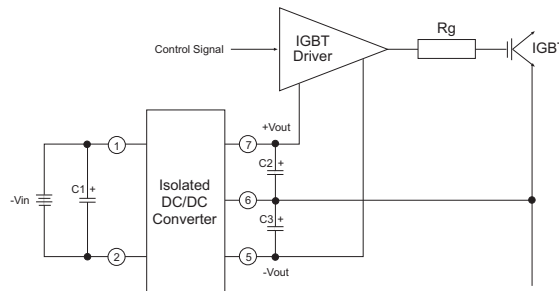

RP

Package Style and Pinning (mm)

7 PIN SIP Package

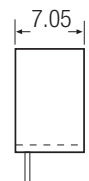
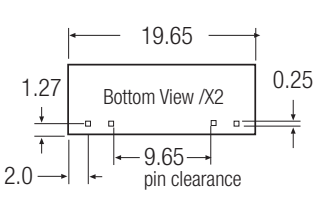
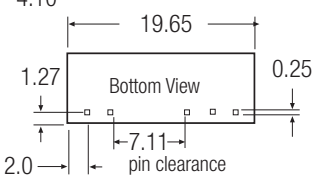
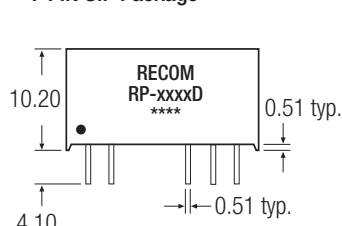

Recommended Footprint Details

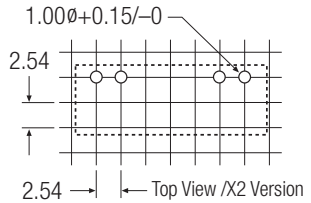
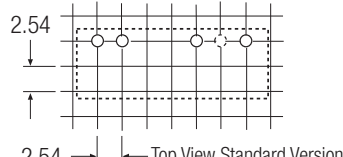

Single Output

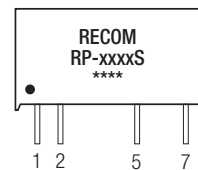

Dual Output

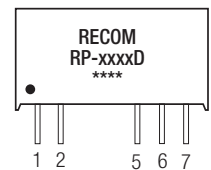

Single Output/X2

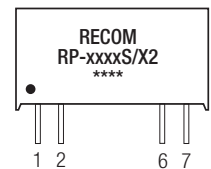

Dual Output

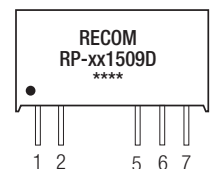

Pin Connections

Pin #	Single	Dual	/X2
1	+Vin	+Vin	+Vin
2	-Vin	-Vin	-Vin
5	-Vout	-Vout	No Pin
6	No Pin	Com	-Vout
7	+Vout	+Vout	+Vout

XX.X ± 0.5 mm
XX.XX ± 0.25 mm

Features

Unregulated Converters

- UL/CSA and EN Safety certified
- EN-60601 for Medical Applications
- Isolation 6.4kVDC
- Optional Continuous Short Circuit Protected
- /X2 Option for >9mm Input/Output Clearance
- Suitable for IGBT Applications

Description

The RxxPxxS_D Series of DC/DC Converters are certified to UL/CSA-60950 as well as EN60950 and EN60601. This makes them ideal for medical and safety applications where approved isolation is required.

Selection Guide

Part Number SIP 7	Input Voltage (VDC)	Output Voltage (VDC)	Output Current (mA)	Efficiency Std (%)	Max Capacitive Load ⁽¹⁾
RxxP3.3S*	5, 9, 12, 15, 24	3.3	303	70	2200µF
RxxP05S*	5, 9, 12, 15, 24	5	200	70-75	1000µF
RxxP09S*	5, 9, 12, 15, 24	9	111	70-75	1000µF
RxxP12S*	5, 9, 12, 15, 24	12	84	70-75	470µF
RxxP15S*	5, 9, 12, 15, 24	15	66	75-80	470µF
RxxP3.3D*	5, 9, 12, 15, 24	±3.3	±151	70	±1000µF
RxxP05D*	5, 9, 12, 15, 24	±5	±100	70-75	±470µF
RxxP09D*	5, 9, 12, 15, 24	±9	±55	70-75	±470µF
RxxP12D*	5, 9, 12, 15, 24	±12	±41	70-75	±220µF
RxxP15D*	5, 9, 12, 15, 24	±15	±33	75-80	±220µF
RxxP1509D*	12, 24	+15/-9	+33/-56	70-80	±220µF
R05P1509D*	5	+15/-9	±42	70-80	+68µF/-220µF

xx = Input Voltage. Other input and output voltage combinations available on request.

* add Suffix "P" for Continuous Short Circuit Protection, e.g. R05P05S/P, R05P05D/P

* add Suffix "/X2" for single output with alternative pinout, e.g. R05P05S/X2, R05P05S/P/X2

Specifications (measured at $T_A = 25^\circ\text{C}$, nominal input voltage, full load and after warm-up)

Input Voltage Range	±10%	
Output Voltage Accuracy	±5%	
Line Voltage Regulation	1.2%/1% of V_{in} typ.	
Load Voltage Regulation (10% to 100% full load)	3.3, 5V output types	15% max.
	other output types, RxxP1509D	10% max.
Output Ripple and Noise (20MHz BW)	200mVp-p max.	
Operating Frequency	20kHz min. / 50kHz typ. / 85kHz max.	
	RxxP1509D	20kHz min. / 60kHz typ.
Efficiency at Full Load	65% min. / 75% typ.	
Minimum Load = 0%	Specifications valid for 10% minimum load only	
Isolation Voltages	(tested for 1 second)	6400VDC
	(rated for 1 minute**)	3200VAC / 60Hz
Isolation Capacitance	4pF min. / 10pF max.	
Isolation Resistance	15 GΩ min.	
Short Circuit Protection	1 Second	
P-Suffix	Continuous	
Operating Temperature Range (free air convection, without derating)	-40°C to +90°C (see Graph)	
Storage Temperature Range	-55°C to +125°C	
Relative Humidity	95% RH	

continued on next page

ECONOLINE

DC/DC-Converter

with 3 year Warranty

RECOM

1 Watt

SIP 7 Single

& Dual Output



EN-60950-1 Certified
IEC/EN-60601-1 Certified*
CSA/UL-60950-1 Certified*
*** +15/-9 Version excluded**

RxxPxx

Derating-Graph

(Ambient Temperature)

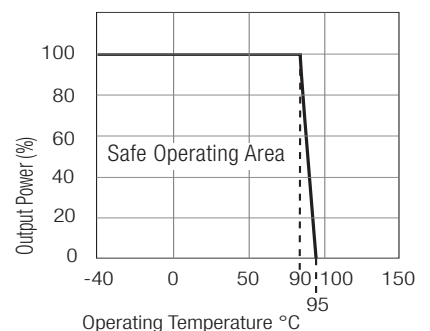

**Any data referred to in this datasheet are of indicative nature and based on our practical experience only. For further details, please refer to our Application Notes.

Refer to Application Notes

Specifications (measured at $T_A = 25^\circ\text{C}$, nominal input voltage, full load and after warm-up))

Package Weight			4.3g
Packing Quantity			25 pcs per Tube
MTBF (+25°C)	Detailed Information see Application Notes chapter "MTBF"	using MIL-HDBK 217F	2974 x 10 ³ hours
(+85°C)		using MIL-HDBK 217F	728 x 10 ³ hours
Certifications			
UL/cUL General Safety	Report: E358085	UL 60950-1 2nd Ed.	
EN General Safety	Report: SPCLVD1109103	EN60950-1:2006 + A12: 2011	
EN Medical Safety	Report: SPCMDD1205098-4	IEC/EN60601-1:2006, 3rd Edition	

Notes

Note 1 Maximum capacitive load is defined as the capacitive load that will allow start up in under 1 second without damage to the converter.

Tolerance Envelope

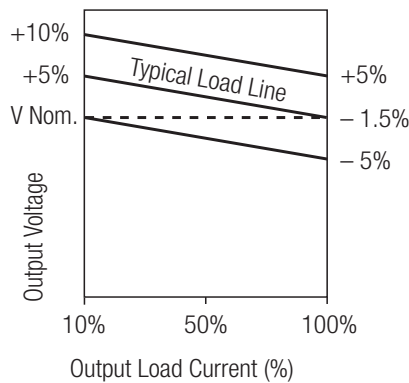

Typical Characteristics

RxxPxx

RxxP05S
RxxP09S

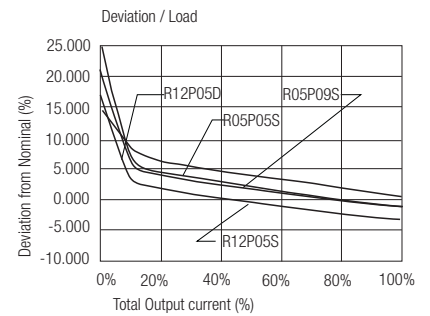
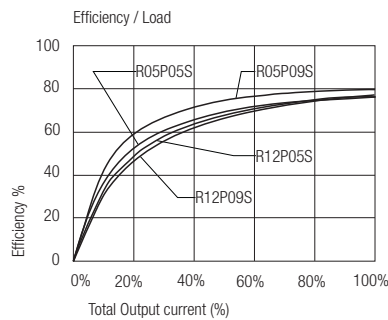

RxxP05D
RxxP09D

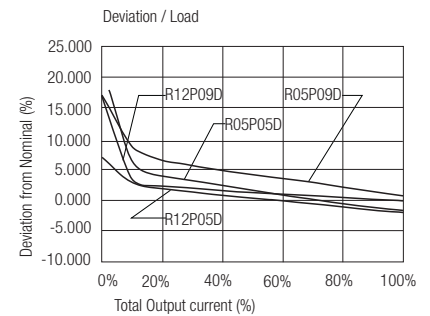
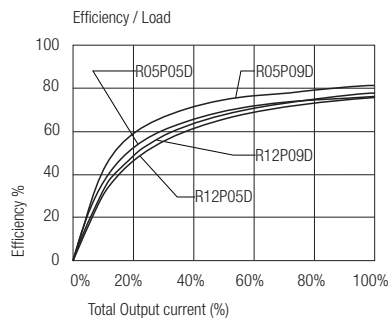

Typical Characteristics

RxxP12S RxxP15S

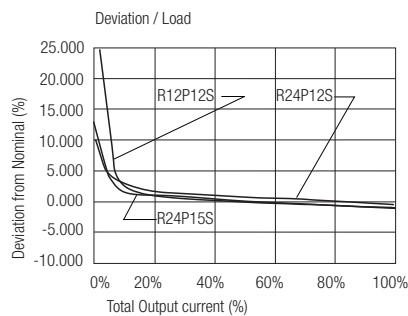
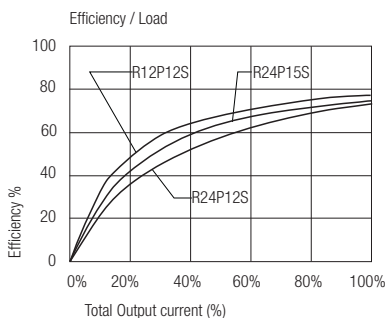

RxxP12D RxxP15D

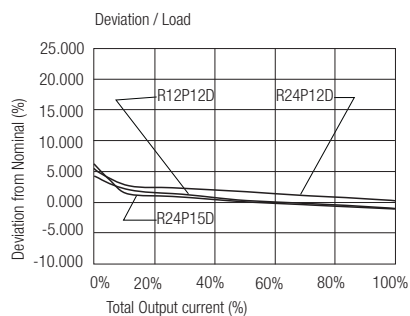
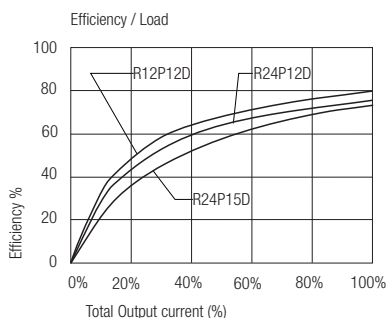

RxxPxx

Application

IGBT Application Circuit

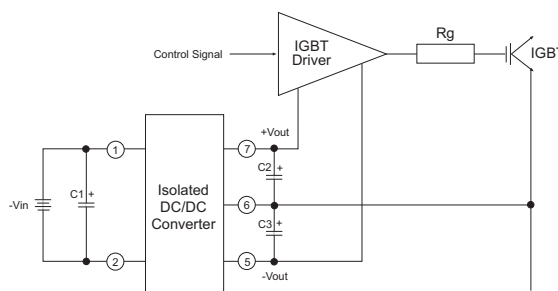

Package Style and Pinning (mm)

7 PIN SIP Package

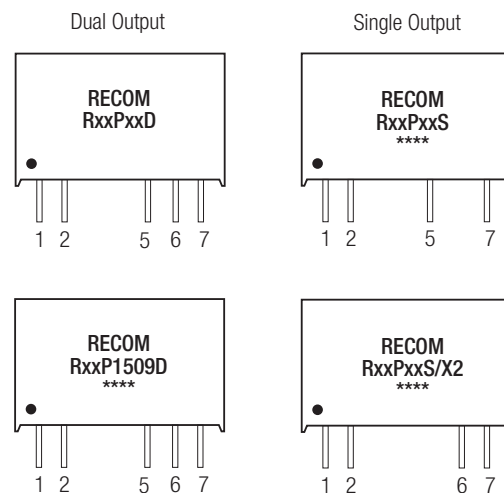
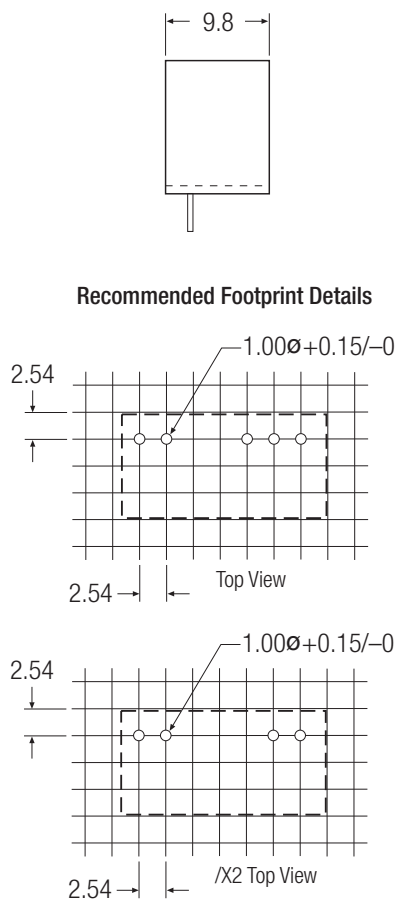
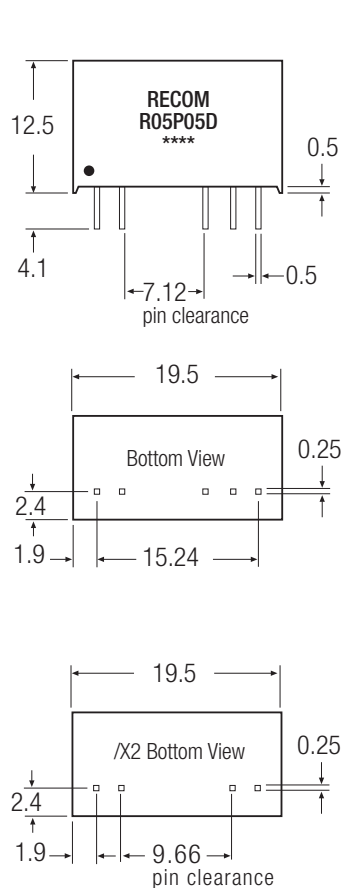

Pin Connections

Pin #	Single	Dual	/X2
1	+Vin	+Vin	+Vin
2	-Vin	-Vin	-Vin
5	-Vout	-Vout	No Pin
6	No Pin	Com	-Vout
7	+Vout	+Vout	+Vout

XX.X ± 0.5 mm
XX.XX ± 0.25 mm

Features

Unregulated Converters

- UL/CSA and EN Safety certified
- EN-61010 for Test, Measurement and Lab Use
- EN-60601 for Medical Applications
- Reinforced Isolation 6.4kVDC or 8kVDC
- Optional Continuous Short Circuit Protected
- Unique Reinforced Isolation Transformer System
- /X2 Option for >9mm Input/Output Clearance

Description

The RxxPxxS_D Series of DC/DC Converters are certified to UL/CSA-60950. This makes them ideal for safety applications where approved or reinforced isolation is required. The reinforced versions are also EN61010-1 certified for Lab Equipment Safety.

Selection Guide

Part Number	Reinforced Isolation (kVDC)	Input Voltage (VDC)	Output Voltage (VDC)	Output Current (mA)	Efficiency Std (%)	Max Capacitive Load ⁽¹⁾
RxxP3.3S	/R6.4 & /R8	5, 9, 12, 15, 24	3.3	303	70~80	2200µF
RxxP05S	/R6.4 & /R8	5, 9, 12, 15, 24	5	200	75-80	1000µF
RxxP09S	/R6.4 & /R8	5, 9, 12, 15, 24	9	111	75-82	1000µF
RxxP12S	/R6.4 & /R8	5, 9, 12, 15, 24	12	84	75-82	470µF
RxxP15S	/R6.4 & /R8	5, 9, 12, 15, 24	15	66	75-83	470µF
RxxP3.3D	/R6.4 & /R8	5, 9, 12, 15, 24	±3.3	±151	72-79	±1000µF
RxxP05D	/R6.4 & /R8	5, 9, 12, 15, 24	±5	±100	75-82	±470µF
RxxP09D	/R6.4 & /R8	5, 9, 12, 15, 24	±9	±55	75-82	±470µF
RxxP12D	/R6.4 & /R8	5, 9, 12, 15, 24	±12	±41	75-82	±220µF
RxxP15D	/R6.4 & /R8	5, 9, 12, 15, 24	±15	±33	75-83	±220µF

xx = Input Voltage. Other input and output voltage combinations available on request.

* add Suffix "P" for Continuous Short Circuit Protection, e.g. R05P05S/P, R05P05D/P

* add Suffix "X2" for single output with alternative pinout, e.g. R05P05S/X2, R05P05S/P/X2

* add Suffix "/R6.4" or "/R8" for Reinforced Isolation, e.g. R05P05D/R6.4, R05P05S/P/X2/R8

Specifications (measured at $T_A = 25^\circ\text{C}$, nominal input voltage, full load and after warm-up)

Input Voltage Range	±10%	
Output Voltage Accuracy	±5%	
Line Voltage Regulation	1.2%/1% of Vin typ.	
Load Voltage Regulation	3.3, 5V output types	15% max.
(10% to 100% full load)	other output types	10% max.
Output Ripple and Noise (20MHz BW)	200mVp-p max.	
Operating Frequency	20kHz min. / 50kHz typ. / 85kHz max.	
Efficiency at Full Load	65% min. / 75% typ.	
Minimum Load = 0%	Specifications valid for 10% minimum load only.	
Reinforced Isolation /R6.4	(tested for 1 second)	6400VDC
	(rated for 1 minute**)	3200VAC / 60Hz
Reinforced Isolation /R8	(tested for 1 second)	8000VDC
	(rated for 1 minute**)	4000VAC / 60Hz
Isolation Capacitance	4pF min. / 10pF max.	
Isolation Resistance	15 GΩ min.	
Short Circuit Protection	1 Second	
P-Suffix	Continuous	
Operating Temperature Range (free air convection)	-40°C to +85°C (see Graph)	
Case Temperature	105°C max.	
Storage Temperature Range	-55°C to +125°C	
Relative Humidity	95% RH	
Package Weight	4.3g	
Packing Quantity	25 pcs per Tube	

continued on next page

ECONOLINE

DC/DC-Converter

with 3 year Warranty

RECOM

1 Watt

SIP 7 Single

& Dual Output



EN-60950-1 Certified

EN-60601-1 Certified

UL/CSA 60950-1 Certified

UL-60601-1 Certified

EN-61010-1 Certified

IEC-60601-1 CB Report

RxxPxx/R

Derating-Graph

(Ambient Temperature)

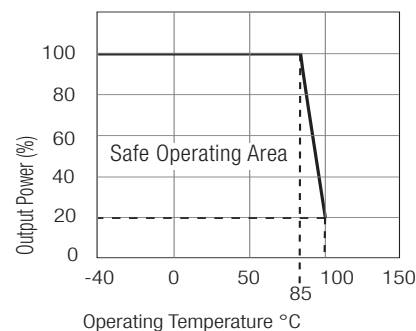

**Any data referred to in this datasheet are of indicative nature and based on our practical experience only. For further details, please refer to our Application Notes.

Refer to Application Notes

Specifications (measured at $T_A = 25^\circ\text{C}$, nominal input voltage, full load and after warm-up)

Potting Material	Silicone Rubber Compound (UL94V-0)		
MTBF (+25°C)	} Detailed Information see Application Notes chapter "MTBF"	using MIL-HDBK 217F	2974 x 10 ³ hours
(+85°C)		using MIL-HDBK 217F	728 x 10 ³ hours
Reinforced Isolation			
Transformer Clearance	Reinforced Types	5.5 mm min.	
PCB Creepage & Clearance	Reinforced Types	4.6 mm min.	
Certifications			
Measurement, Control and Laboratory Use Safety	Report: T1301251-313	EN 61010-1 : 2010	
CSA General Safety		UL 60950-1 1st Ed. C22.2 No. 60950-1-03	
UL/cUL Medical Safety	Report: E314885-A5	UL60601-1 3rd Edition	
CSA Medical Safety	Report: 2207629	CAN/CSA-22.2 No 601.1-M90	
EN General Safety	Report: SPCLVD1310079-1	EN60950-1 : 2006	
CB/EN Medical Safety	Report: CA-10169-A1-UL	IEC/EN 60601-1 3rd Edition	

Notes

Note 1 Maximum capacitive load is defined as the capacitive load that will allow start up in under 1 second without damage to the converter.

Tolerance Envelope

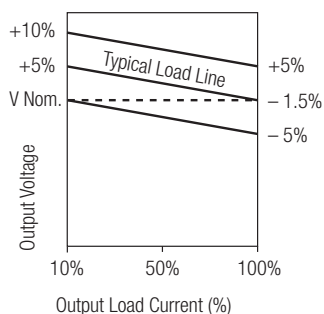

Typical Characteristics - Reinforced Version

RxxP05S/R6.4
RxxP05S/R8

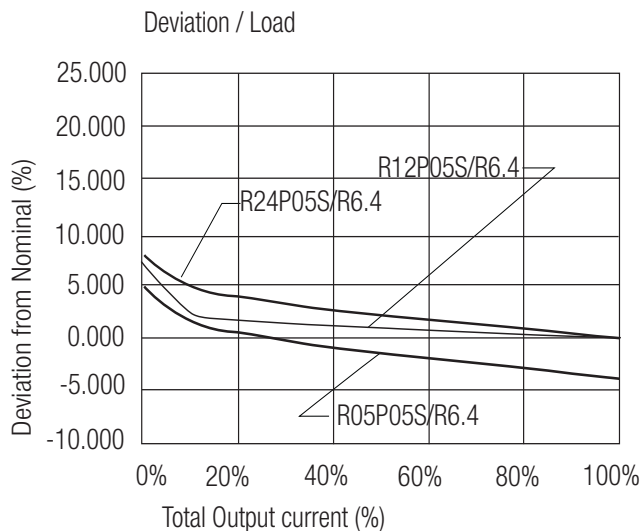
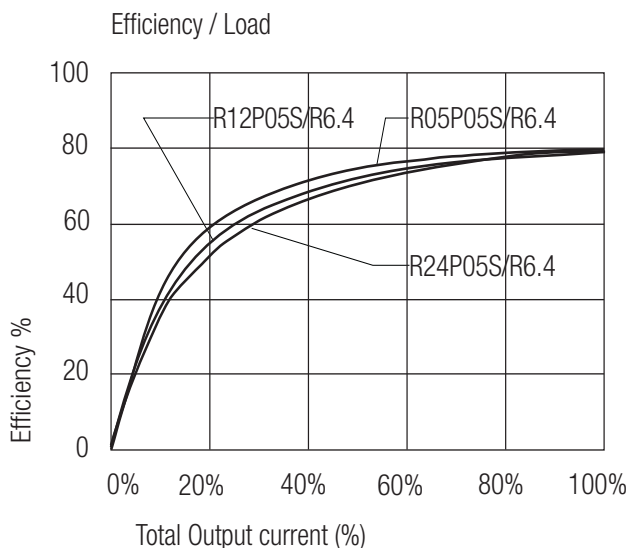

RxxP05D/R6.4 RxxP05D/R8

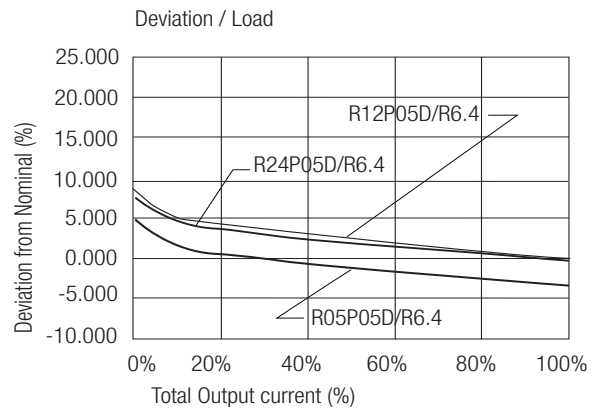
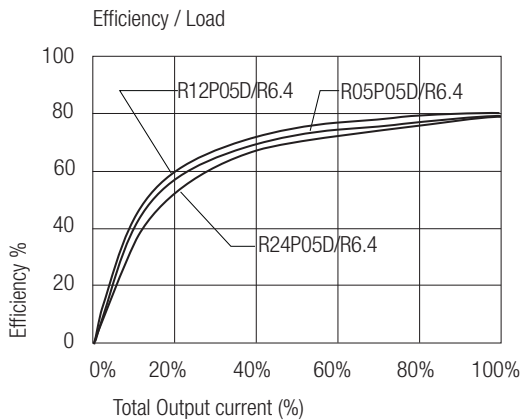

Package Style and Pinning (mm)

7 PIN SIP Package

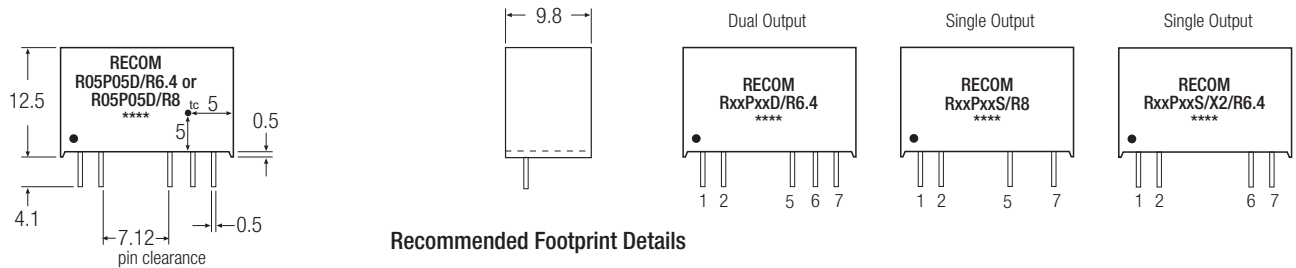

Recommended Footprint Details

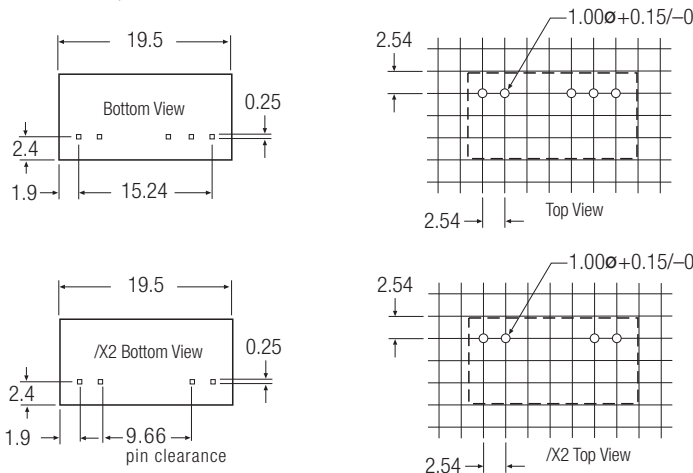

Pin Connections

Pin #	Single	Dual	/X2
1	+Vin	+Vin	+Vin
2	-Vin	-Vin	-Vin
5	-Vout	-Vout	No Pin
6	No Pin	Com	-Vout
7	+Vout	+Vout	+Vout

XX.X ± 0.5 mm
XX.XX ± 0.25 mm

Features

Unregulated Converter

- Fully RoHS 6/6 Conform
- Full Power at 100°C Ambient Temperature
- 1kVDC Isolation
- Suitable for Fully Automated Assembly (including Vapour Phase Soldering)
- Optional Continuous Short Circuit Protection

Description

The R1DA converters are of the enclosed open frame type, i.e. they are not potted. The converters are typically used in general purpose and industrial low power isolation and voltage matching applications where an SMD converter is required. The converter series feature an extended ambient temperature operating range of -40°C to +100°C without derating and optional continuous short circuit protection. In addition to single, dual and independent outputs, two isolation options and three different case formats, the converters are also available prepacked as tape and reel for use with automatic insertion machines.

Selection Guide

Part Number SMD	Input Voltage (VDC)	Output Voltage (VDC)	Output Current (mA)	Efficiency typ. (%)	Max Capacitive Load ^{(1)**}
R1DA**xx3.33.3	3.3, 5, 9, 12, 15, 24	3.3/3.3	150/150	75	470µF/470µF
R1DA**xx0505	3.3, 5, 9, 12, 15, 24	5/5	100/100	72-78	470µF/470µF
R1DA**xx0909	3.3, 5, 9, 12, 15, 24	9/9	56/56	74-78	220µF/220µF
R1DA**xx1212	3.3, 5, 9, 12, 15, 24	12/12	42/42	75-80	68µF/68µF
R1DA**xx1515	3.3, 5, 9, 12, 15, 24	15/15	33/33	75-82	68µF/68µF

xx = Input Voltage (other input and output voltage combinations available on request)

* add Suffix "P" for Continuous Short Circuit Protection, e. g. R1DA-050505/P

* add Suffix -R for Tape & Reel Packing e.g. R1DA-050505-R. For more Details see Application Notes.

Specifications (measured at T_A = 25°C, nominal input voltage, full load and after warm-up)

Input Voltage Range	±10%	
Output Voltage Accuracy	-1% typ., ±5% max.	
Line Voltage Regulation (Low Line to High Line @ max. Load)	All Variants	1% typ.
Load Regulation (10% to 100% Load)	3.3V output types	15% typ., 20% max.
	5V output types	12% typ. / 15% max.
	9V output types	7% typ., 10% max.
	12V, 15V output types	6% typ., 10% max.
Output Ripple and Noise (20MHz BW limited)	50 mVp-p typ. / 100mVp-p max.	
Operating Frequency	20kHz min. / 50kHz typ. / 90kHz max.	
Efficiency at Full Load	See Selection Guide	
Minimum Load = 0%	Specifications valid for 10% minimum Load only	
Isolation Voltage Input/Output	(tested for 1 second)	1000VDC
Isolation Voltage Output/Output	(rated for 1 minute**)	500VAC / 60Hz
Isolation Capacitance	75pF max.	
Isolation Resistance	V _{iso} =500V	10 GΩ min.
Short Circuit Protection	1 Second	
P-Suffix	Continuous	
Operating Temperature Range	-40°C to +100°C (see Graph)	
Storage Temperature Range	-50°C to +125°C	
Reflow Temperature	RoHS compliant	245°C (30 sec), Peak 255°C (5 sec) max.
Vapour Phase Process	(for more details see Application Notes) 230°C (90 sec) max.	
Relative Humidity	95% RH	
Humidity Susceptibility Test	1000 hrs / 90% humidity / +85°C ambient	

continued on next page

**Any data referred to in this datasheet are of indicative nature and based on our practical experience only. For further details, please refer to our Application Notes.

ECONOLINE
DC/DC-Converter

RECOM

1 Watt SMD Dual Independent Outputs



EN-60950-1-Certified
UL-60950-1-Certified

R1DA

Derating-Graph (Ambient Temperature)

R1DA-0505

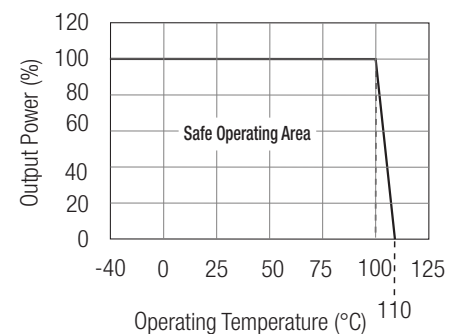

Refer to Application Notes

Specifications (measured at $T_A = 25^\circ\text{C}$, nominal input voltage, full load and after warm-up)

Package Weight		1.2g
Packing Quantity		33 pcs per tube / 500 pcs per reel
MTBF	Using MIL-HDBK 217F (+25°C)	1045 x 10 ³ hours
	Using MIL-HDBK 217F (+85°C)	183 x 10 ³ hours

Detailed Information see Application Notes chapter „MTBF“

Certifications

EN General Safety	Report: 10010807-2009	EN-60950-1, 2nd Edition
Conducted Emissions		EN55022 Class B with Filter
Radiated Emissions		EN55022 Class B with Filter
UL General Safety	Report: E358085	UL60950-1, 2nd Edition

Notes

Note 1: Maximum capacitive load is defined as the capacitive load that will allow start up in under 1 second without damage to the converter.

Tolerance Envelope

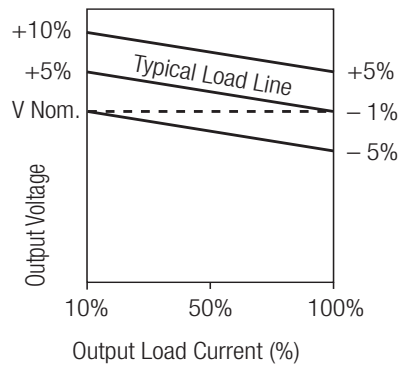

Typical Characteristics

R1DA-xx0505

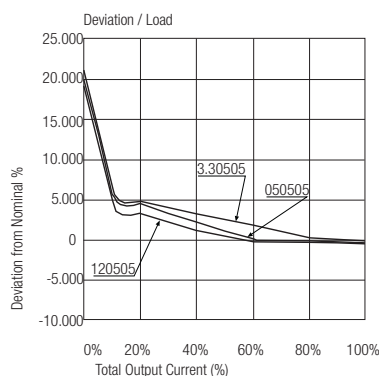
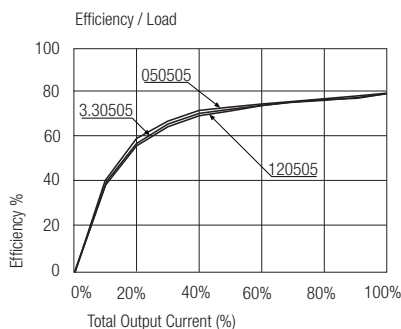

R1DA-xx1212

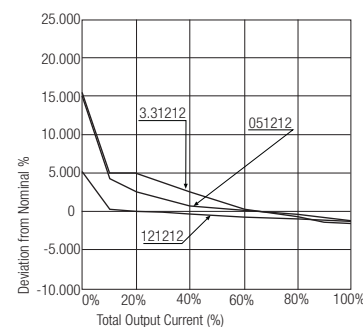
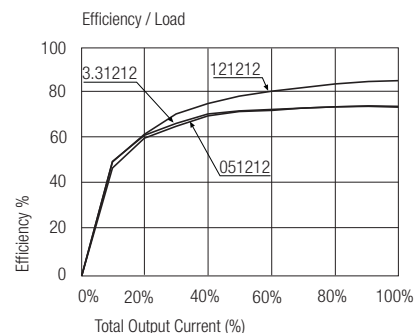

Package Style and Pinning (mm)

2 PIN Dual SMD Package

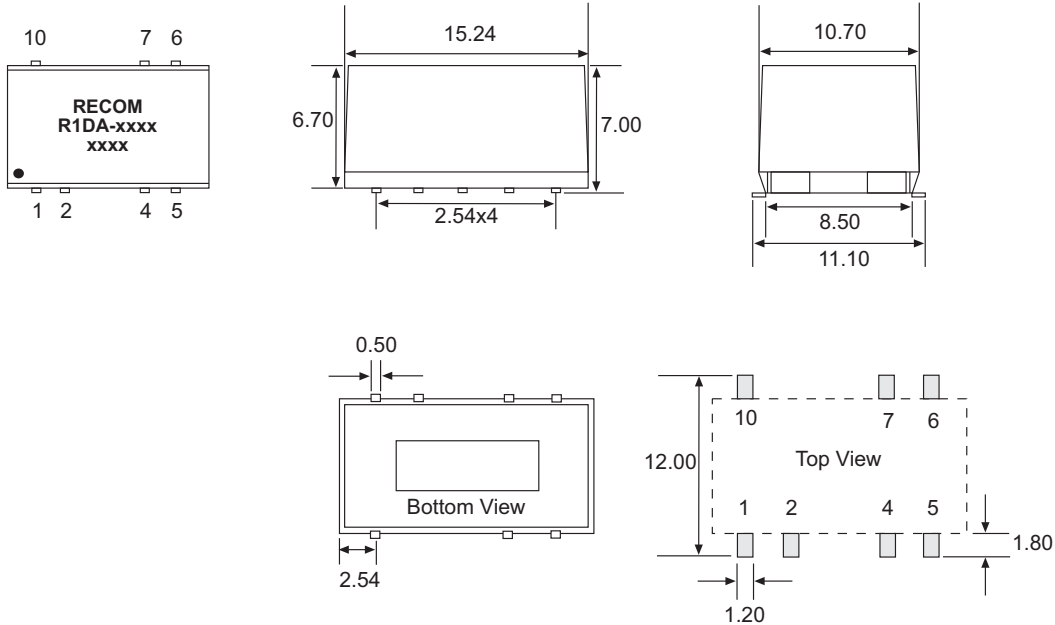

Pin Connections

Pin #	Function
1	-Vin
2	+Vin
4	-Vout1
5	+Vout1
6	-Vout2
7	+Vout2
10	NC

NC= No Connection

EMC Filtering - Suggestion for EN55022 Class B (Conducted and Emmited)

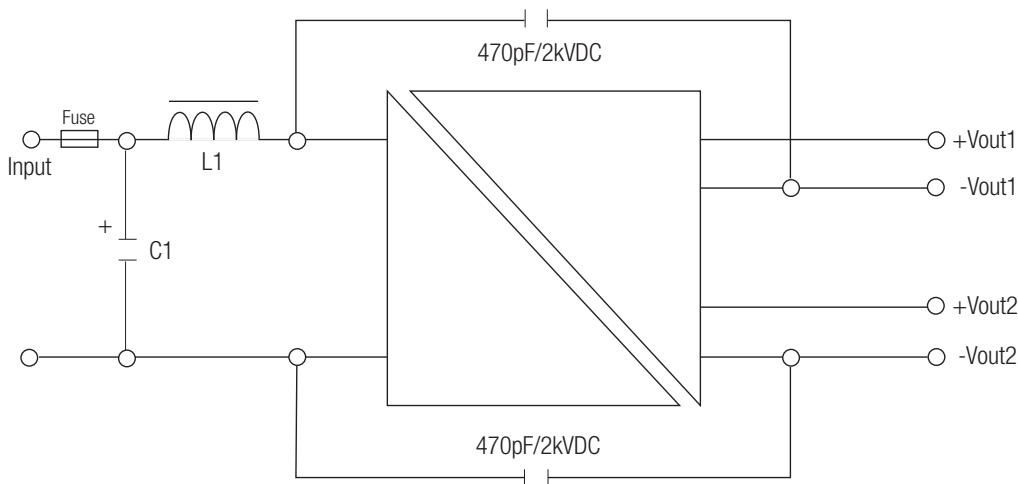

Standard

C1	L1	Vin
2.2μF	4.7μH	3.3V
2.2μF	4.7μH	5V
2.2μF	10μH	9V
2.2μF	10μH	12V
2.2μF	10μH	15V
2.2μF	22μH	24V

/P versions

C1	L1	Vin
4.7μF	10μH	3.3V
4.7μF	10μH	5V
4.7μF	10μH	9V
4.7μF	10μH	12V
4.7μF	22μH	15V

C1 = MLCC
L1 = SMD Inductor

Features

Unregulated Converters

- Twin Independent Outputs
- Output/Output Isolation 1kVDC
- Power Sharing on Outputs
- Input/Output Isolation 1kVDC
- Standard and Miniature Versions
- Optional Continuous Short Circuit Protected
- Custom Solutions Available
- Efficiency to 76%

Description

The RU DC/DC converter offers two independent isolated outputs. Typical applications include multiple channel circuits where inter-channel isolation is also required.

The RUM offers similar specifications in a miniature case for applications where space is at a premium. Both converters offer 1KVDC input/output isolation and 1KVDC output/output isolation. The /H versions offer 2KVDC isolation between input and outputs.

Selection Guide

Part Number	SIP 7	Input Voltage (VDC)	Output Voltage (V1VDC)	Output Voltage (V2VDC)	Output Current (mA)	Efficiency typ. (%)	Max Capacitive Load ⁽¹⁾
RU-3.30505	(H)	3.3	5	5	100/100	76	470µF/470µF
RU-050505	(H)	5	5	5	100/100	72	470µF/470µF
RUM-3.30505	(H)	3.3	5	5	100/100	78	470µF/470µF
RUM-050505	(H)	5	5	5	100/100	72	470µF/470µF

Other input and output voltage combinations available on request

* add Suffix "P" for Continuous Short Circuit Protection,
e.g. RU-050505/P, RUM-050505/P, RU-3.30505/HP

Specifications (measured at $T_A = 25^\circ\text{C}$, nominal input voltage, full load and after warm-up)

Input Voltage Range		±10%	
Output Voltage Accuracy		±5%	
Line Voltage Regulation		1.2%/1% of V_{in} typ.	
Load Voltage Regulation (10%~100% Load)		15% max 10% typ.	
Output Ripple and Noise (20MHz limited)	RU	75mVp-p max.	
Full Load	RUM	100mVp-p max.	
Operating Frequency		20kHz min. / 70kHz typ. / 105kHz max.	
Efficiency at Full Load	RU	70% min.	
	RUM	70% min.	
Minimum Load = 0%	Specifications valid for 10% minimum load only.		
Isolation Voltage	(tested for 1 second)	1000VDC	
Input/Output and Output/Output	(rated for 1 minute**)	500VAC / 60Hz	
Isolation Voltage	H-suffix (tested for 1 second)	2000VDC	
Input/Output	H-suffix (rated for 1 minute**)	1000VAC / 60Hz	
Output/Output	H-suffix (rated for 1 minute**)	500VAC / 60Hz	
Isolation Capacitance		20pF min. / 94pF max.	
Isolation Resistance		10 GΩ min.	
Short Circuit Protection		1 Second	
P-Suffix		Continuous	
Operating Temperature Range (free air convection)		-40°C to +85°C (see Graph)	
Storage Temperature Range		-55°C to +125°C	
Relative Humidity		95% RH	
Package Weight		2.7g	
Packing Quantity	RU	25 pcs per Tube	
	RUM	30 pcs per Tube	
MTBF (+25°C)	Detailed Information see Application Notes chapter "MTBF"	using MIL-HDBK 217F	1012 x 10 ³ hours
(+85°C)		using MIL-HDBK 217F	151 x 10 ³ hours

Certifications

EN60950-1

Report: SPCLVD1109103

EN60950-1: 2006+A12:2011

ECONOLINE

DC/DC-Converter

with 3 year Warranty

RECOM

1 Watt

SIP7

Isolated

Dual Output

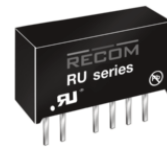

EN-60950-1 Certified

RU/RUM

Derating-Graph

(Ambient Temperature)

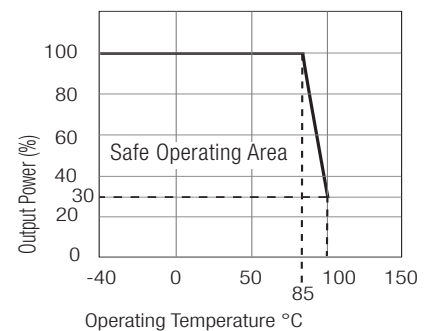

**Any data referred to in this datasheet are of indicative nature and based on our practical experience only. For further details, please refer to our Application Notes.

Refer to Application Notes

Typical Characteristics

RU-050505
RUM-050505

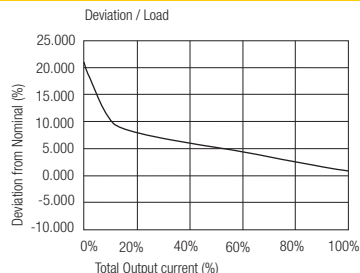
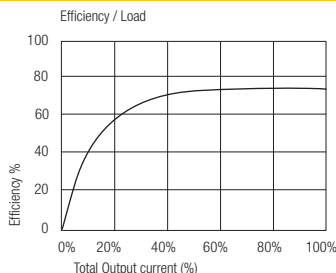

Notes
Note 1 Maximum capacitive load is defined as the capacitive load that will allow start up in under 1 second without damage to the converter.

RU Package Style and Pinning (mm)

SIP7 Package

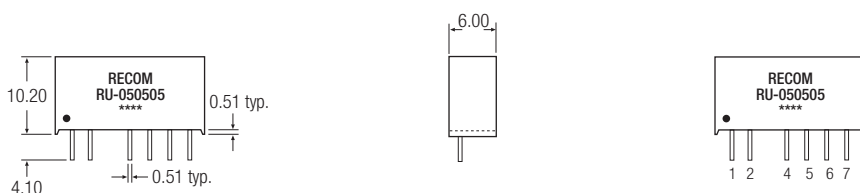

Recommended Footprint Details

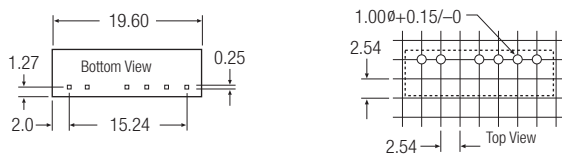

Pin Connections

Pin #	Single
1	+Vin
2	-Vin
4	+Vout 1
5	-Vout 1
6	+Vout 2
7	-Vout 2

XX.X \pm 0.5 mm
XX.XX \pm 0.25 mm

RU/RUM

RUM Package Style and Pinning (mm)

SIP6 Package

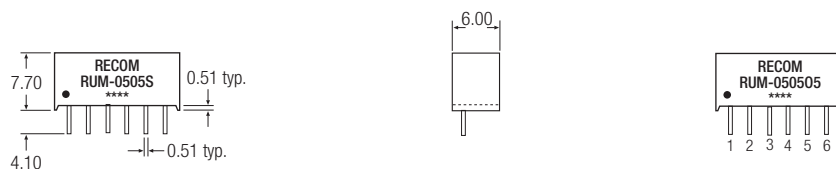

Recommended Footprint Details

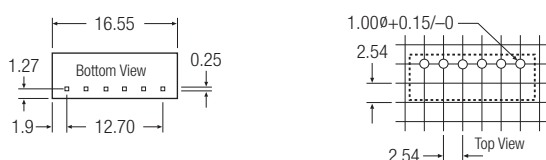

Pin Connections

Pin #	Single
1	+Vin
2	-Vin
3	-Vout 1
4	+Vout 1
5	-Vout 2
6	+Vout 2

XX.X \pm 0.5 mm
XX.XX \pm 0.25 mm

Typical Application

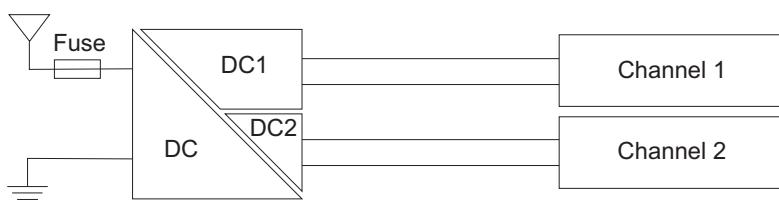

The product information and specifications are subject to change without prior notice. All products are designed for non-safety critical commercial and industrial applications. The Buyer agrees to implement safeguards that anticipate the consequences of any failures that might cause harm, loss of life and/or damage property.

Features

Unregulated Converters

- Custom Solutions Available
- 1kVDC & 2kVDC Isolation
- No Extern. Components Required
- UL94V-0 Package Material
- No Heatsink Required
- Efficiency to 85%

Description

The RN series of compact 1.25W single output converters are especially useful when more than 1W of power is required, but there are space restrictions than make a 2W converter unsuitable. The converter series feature an industrial ambient temperature operating range of -40°C to +85°C without derating and up to 100°C ambient temperature with derating. Options include 1kVDC or 2kVDC isolation and continuous short circuit protection (P).

Selection Guide

Part Number	Input Voltage (VDC)	Output Voltage (VDC)	Output Current (mA)	Efficiency (%)	Max. Capacitive Load ⁽¹⁾
RN-xx3.3S	(H) 3.3, 5, 9, 12, 15, 24	3.3	378	70	2200µF
RN-xx05S	(H) 3.3, 5, 9, 12, 15, 24	5	250	70-72	1000µF
RN-xx07S	(H) 3.3, 5, 9, 12, 15, 24	7	180	72-75	1000µF
RN-xx09S	(H) 3.3, 5, 9, 12, 15, 24	9	140	75-80	1000µF
RN-xx12S	(H) 3.3, 5, 9, 12, 15, 24	12	104	79-82	470µF
RN-xx15S	(H) 3.3, 5, 9, 12, 15, 24	15	84	80-84	470µF
RN-xx24S	(H) 3.3, 5, 9, 12, 15, 24	24	52	80-85	220µF

x = Input Voltage (other input and output voltage combinations available on request)

* add Suffix "P" for Continuous Short Circuit Protection, e.g. RN-0505S/P, RN-0505S/HP

Specifications (Core Operating Area)

Input Voltage Range		±10%
Output Voltage Accuracy		±5%
Line Voltage Regulation		1.2% typ. / 1.4% max.
Load Voltage Regulation	3.3V output types	20% max.
(10% to 100% full load)	5V output type	15% max.
	9V, 12V, 15V, 24V output types	10% max.
Output Ripple and Noise (20MHz limited)		75mVp-p max.
Operating Frequency		50kHz min. / 100kHz typ. / 105kHz max.
Efficiency at Full Load		70% min. / 75% typ.
Minimum Load = 0%	Specifications valid for 10% minimum load only.	
Isolation Voltage	(tested for 1 second)	1000VDC
	(rated for 1 minute**)	500VAC / 60Hz
Isolation Voltage	H-Suffix (tested for 1 second)	2000VDC
	H-Suffix (rated for 1 minute**)	1000VAC / 60Hz
Isolation Capacitance		30pF min. / 95pF max.
Isolation Resistance		10 GΩ min.
Short Circuit Protection		1 Second
Operating Temperature Range (free air convection)		-40°C to +85°C (see Graph)
Storage Temperature Range		-55°C to +125°C
Relative Humidity		95% RH
Package Weight	1.9g	
Packing Quantity		39 pcs per Tube
MTBF (+25°C)	Detailed information page 266	using MIL-HDBK 217F
(+85°C)		using MIL-HDBK 217F

Certifications

EN General Safety Report: SPCLVD1109103 EN60950-1:2006 + A12:2011

ECONOLINE

DC/DC-Converter

with 3 year Warranty

RECOM

1.25 Watt DIP8 Single Output

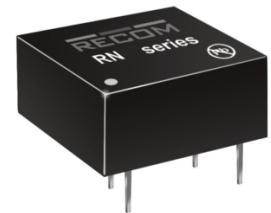

EN-60950-1 Certified

RN

Derating-Graph (Ambient Temperature)

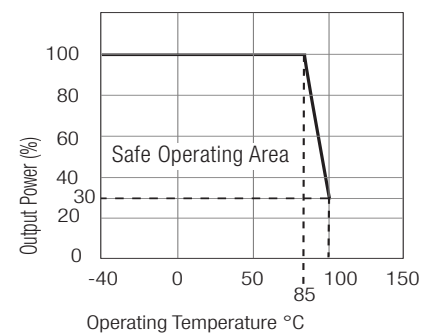

**Any data referred to in this datasheet are of indicative nature and based on our practical experience only. For further details, please refer to our Application Notes.

Refer to Application Notes

Typical Characteristics

RN-xx05S

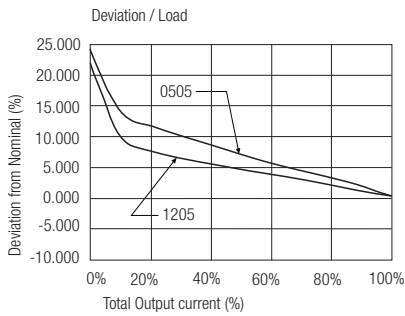
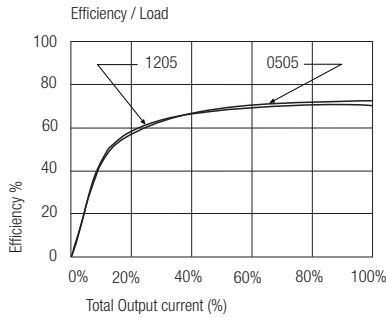

RN-xx12S

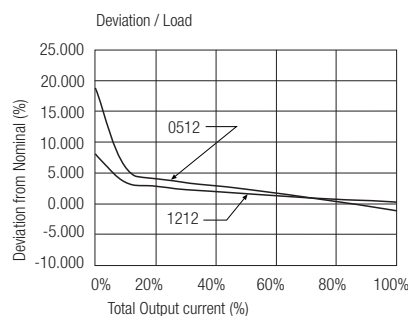
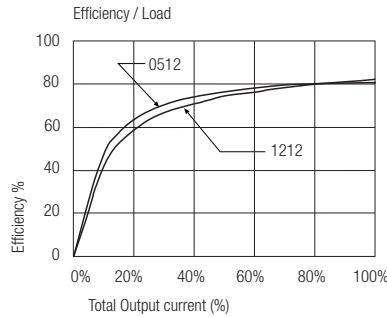

RN-xx15S

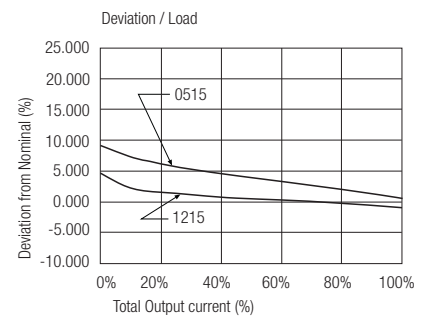
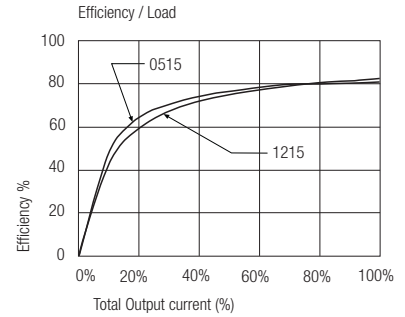

Notes

Note 1 Maximum capacitive load is defined as the capacitive load that will allow start up in under 1 second without damage to the converter.

RN

Package Style and Pinning (mm)

DIP8 Package

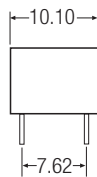
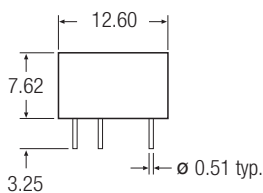

Recommended Footprint Details

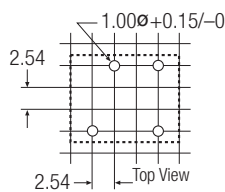
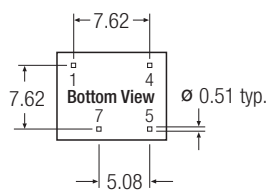

Pin Connections

Pin #	Single
1	-Vin
4	+Vin
5	+Vout
7	-Vout
XX.X	± 0.5 mm
XX.XX	± 0.25 mm

Features

Unregulated Converters

- 1:1 Input Range
- Efficiency up to 84%
- 2kVDC and 3kVDC Isolation Option
- Approved for Medical Applications
- -40°C to +90°C Operating Temperature Range
- 2W SMD Package

Selection Guide

Part Number	Isolation Voltage (kV)	Input Voltage (VDC)	Output Voltage (VDC)	Output Current (mA)	Efficiency (max.)	Capacitive Load (max.) ⁽¹⁾
RTM-0505S*	2	5	5	400	79%	2200µF
RTM-1205S*	2	12	5	400	83%	2200µF
RTM-2405S*	2	24	5	400	84%	2200µF

* add Suffix "/H" for 3kVDC/1sec. Isolation e.g. RTM-0505S/H

* add Suffix "-R" for tape&reel packing e.g. RTM-1205S-R or RTM-2405S/H-R

Specifications (measured at T_A = 25°C, nominal input voltage and rated output current unless otherwise specified)

Input Voltage Range			±10% max.
Output Voltage Accuracy			-1% typ., ±5% max.
Line Voltage Regulation	(low line to high line at max. load)		1.2% typ.
Load Voltage Regulation	(10% to 100% full load)		10% typ., 15% max.
Output Ripple and Noise (20MHz BW limited)			50mVp-p typ., 100mVp-p max.
Operating Frequency (V _{in} =nominal input)			20kHz min. / 40kHz typ. / 80kHz max.
Efficiency at Full Load			see Selection Guide
Minimum Load = 0%			Specifications valid for 10% minimum load only
Isolation Voltage	(tested for 1 second)		2000 VDC
	(rated for 1 minute**)		1600VDC
Isolation Voltage	H-Suffix	(tested for 1 second)	3000 VDC
	H-Suffix	(rated for 1 minute**)	2400VDC
Isolation Capacitance			30pF typ., 50pF max.
Isolation Resistance	(V _{iso} =500V)		15GΩ min.
Short-Circuit Protection			1 second
Operating Temperature Range	with Derating		-40°C to +90°C
Storage Temperature			-55°C to +125°C
Reflow Temperature	RoHS compliant	245°C (30 sec.), Peak 255°C (5sec.) max.	
Vapour Phase Process	(for more details see Application Notes)		230°C (90 sec.) max.
Relative Humidity			95% RH
Package Weight			1.4g
Packing Quantity	All Types		27 pcs per Tube
	All Types		500 pcs per Reel
MTBF (+25°C)	} Detailed Information see Application Notes chapter "MTBF"	using MIL-HDBK 217F	3907 x 10 ³ hours
MTBF (+85°C)		using MIL-HDBK 217F	313 x 10 ³ hours
Certifications			
EN Medical Safety	Report: MDD1112018 + RM1112018	IEC/EN 60601-1 3rd Edition	
	Medical Report + ISO14971 Risk Assessment		
EN General Safety	Report: SPLVD1112018	EN60950-1, 2nd Edition	

Note:

Note1: Maximum capacitive load is defined as the capacitive load that will allow start up in under 1 second without damage to the converter

ECONOLINE
DC/DC-Converter

RECOM

2 Watt SMD Single Output



EN-60601-1 Certified
EN-60950-1 Certified

RTM

Derating-Graph (Ambient Temperature)

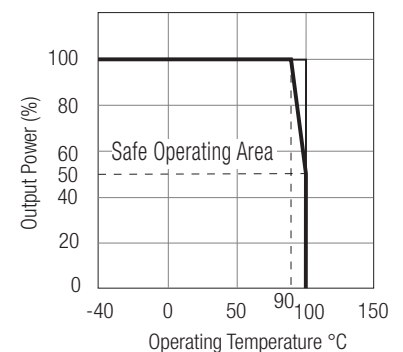

**Any data referred to in this datasheet are of indicative nature and based on our practical experience only. For further details, please refer to our Application Notes.

Refer to Application Notes

Typical Characteristics

RTM-xx05S

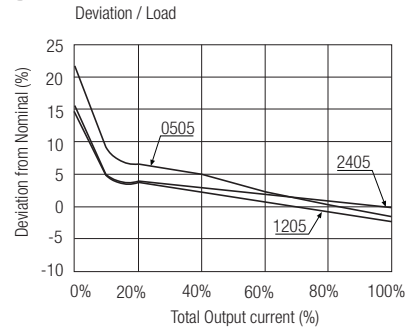
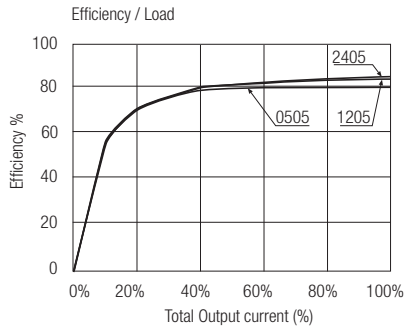

Tolerance Envelope

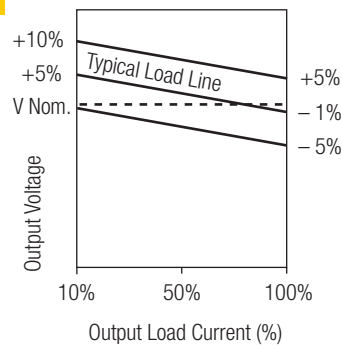

Package Style and Pinning

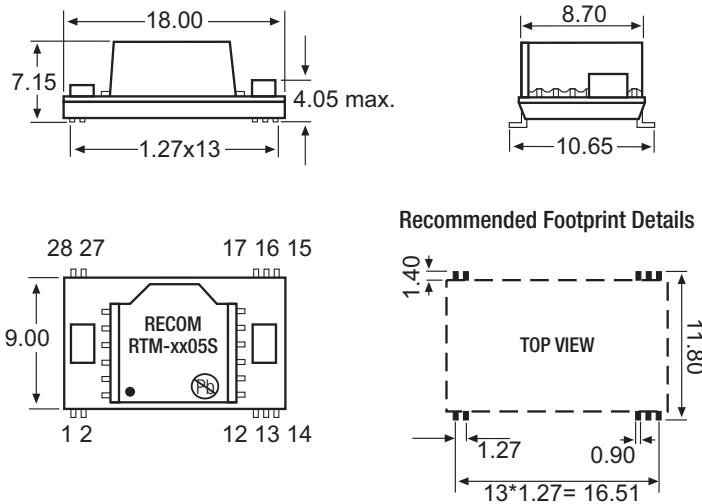

Pin Connections

Pin #	Function
1	+Vin
2	-Vin
12	-Vout
13	+Vout
14-17	NC
27,28	NC

NC = No Connection

Unit: mm
Tolerance: ± 0.25 mm

EMC Filtering - Suggestion for EN55022 Class B

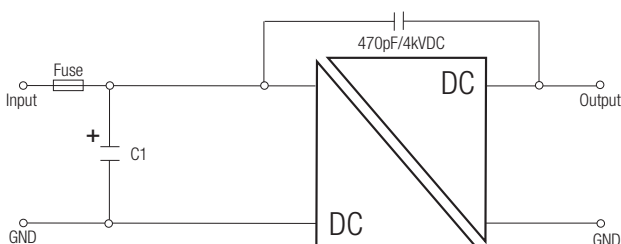

Input Voltage	Inductance/ Capacitance (C1)
5V	4.7µF
12V	2.2µF
24V	47µF

Features

Unregulated Converters

- Fully RoHS 6/6 Conform
- Full Power at 100°C Ambient Temperature
- 1kVDC and 3kVDC Isolation Options
- /H Version Certified for Medical Applications
- UL/EN/CSA Certified, CB Report
- Suitable for Fully Automated Assembly (including Vapour Phase Soldering)
- Optional Continuous Short Circuit Protection
- Efficiency to 85%
- Built-In EN55022 Class A Filter

Description

The R2S and R2D converters are of the enclosed open frame type, meaning that they are un-potted. The converters are typically used in general purpose and industrial low power isolation and voltage matching applications where an SMD converter is required. The converter series feature an extended ambient temperature operating range of -40°C to +100°C without derating and optional continuous short circuit protection. In addition to two isolation options and three different case formats, the converters are also available prepacked as tape and reel for use with automatic insertion machines.

Selection Guide

Part Number	SMD	(3kV)	Input Voltage (VDC)	Output Voltage (VDC)	Output Current (mA)	Efficiency (%)	Max Capacitive Load ⁽¹⁾
R2S** -xx3.3	(H)		5, 12, 15, 24	3.3	606	70-75	3300µF
R2S** -xx05	(H)		5, 12, 15, 24	5	400	76-84	1200µF
R2S** -xx09	(H)		5, 12, 15, 24	9	222	76-84	1200µF
R2S** -xx12	(H)		5, 12, 15, 24	12	167	76-85	680µF
R2S** -xx15	(H)		5, 12, 15, 24	15	133	76-85	680µF
R2S** -xx24	(H)		5, 12, 15, 24	24	83	76-85	220µF
R2D** -xx05	(H)		5, 12, 15, 24	±5	±200	75-80	±470µF
R2D** -xx09	(H)		5, 12, 15, 24	±9	±111	75-80	±470µF
R2D** -xx12	(H)		5, 12, 15, 24	±12	±83	75-83	±330µF
R2D** -xx15	(H)		5, 12, 15, 24	±15	±66	75-85	±330µF
R2D** -xx24	(H)		5, 12, 15, 24	±24	±42	75-85	±330µF

xx = Input Voltage. Other input and output voltage combinations available on request.

* add Suffix "P" for Continuous Short Circuit Protection, e.g. R2S-0505/P, R2D-0505/HP

* add suffix -R for tape&reel packing e.g. R2S-0505-R. For more details see Tapes Section.

Case and Pinning Options (note restrictions on /H option)

- R2S** : ** without marking denotes 5 pins out of 8 fitted (/H option available)
 ** with marking **8** denotes 8 pins out of 8 fitted (/H option not available)
 ** with marking **12** denotes 10 pins out of 12 fitted (/H option available)
- R2D** : ** without marking denotes 6 pins out of 10 fitted (/H option available)
 ** with marking **10** denotes with 10 pins out of 10 fitted (/H option not available)
 ** with marking **12** denotes with 10 pins out of 12 fitted (/H option available)

Specifications (measured at T_A = 25°C, nominal input voltage, full load and after warm-up)

Input Voltage Range		±10%
Output Voltage Accuracy		±5%
Line Voltage Regulation		1.2%/1% of Vin max.
Load Voltage Regulation	3.3V output types	20% max.
(10% to 100% full load)	5V output type	15% max.
	9V, 12V, 15V, 24V output types	10% max.
Output Ripple and Noise (20MHz limited)		150mVp-p max.
Operating Frequency		20kHz min. / 40kHz typ. / 85kHz max.
Efficiency at Full Load		70% min. / 80% typ.
Minimum Load = 0%		Specifications valid for 10% minimum load only.

continued on next page

ECONOLINE

DC/DC-Converter

with 3 year Warranty

RECOM

2 Watt

SMD Single & Dual Output

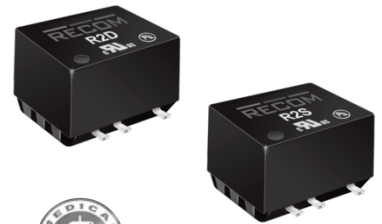

UL-60950-1 Certified
EN-60950-1 Certified
EN-60601-1 Certified*
 (* /H suffix)

R2S-R2D

Derating-Graph (Ambient Temperature)

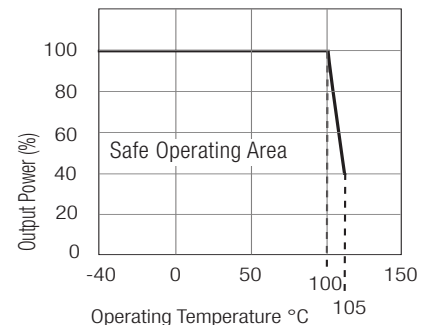

***Any data referred to in this datasheet are of indicative nature and based on our practical experience only. For further details, please refer to our Application Notes.

Refer to Application Notes

Specifications - Continued

Isolation Voltage	(tested for 1 second) (rated for 1 minute***)	1000VDC 500VAC / 60Hz
Isolation Voltage	(tested for 1 second) (rated for 1 minute***)	3000VDC 1500VAC / 60Hz
Isolation Capacitance		115pF max.
Isolation Resistance	(Viso 500V)	10 GΩ min.
Short Circuit Protection		1 Second
P-Suffix		Continuous
Operating Temperature Range (free air convection)		-40°C to +100°C (see Graph)
Storage Temperature Range		-55°C to +125°C
Reflow Temperature	ROHS compliant	245°C (30 sec), peak 255°C (5 sec) max.
Vapour Phase Process	(for more details see Application Notes)	230°C (90 sec) max.
Relative Humidity		95% RH
Package Weight	R2S, R2S8 R2D, R2D10 R2S12, R2D12	1.4g 1.5g 1.6g
Packing Quantity	R2S, R2S8 R2S12, R2D, R2D10, R2D12 All Types	39 pcs per Tube 33 pcs per tube 250 pcs per Reel
MTBF (+25°C) (+85°C)	} Detailed Information see Application Notes chapter "MTBF" using MIL-HDBK 217F	886 x 10 ³ hours 128 x 10 ³ hours
Certifications		
CB Test Report	Report: US/14402/UL	
UL General Safety	Report: E308085	UL 60950-1 2nd Ed.
CUL General Safety		C22.2 No. 60950-1-03
EN Medical Safety	Report: MDD1205098-2 + RM1205098-2 Medical Report + ISO14971 Risk Assessment	IEC/EN 60601-1 3rd Ed.
EN General Safety	Report: SPCLVD 1211033-3	EN60950-1: 2006 + A12:2011
Conducted / Radiated Emissions	EN55022	Level A

Notes

Note 1 Maximum capacitive load is defined as the capacitive load that will allow start up in under 1 second without damage to the converter.

Typical Characteristics

R2S-xx05

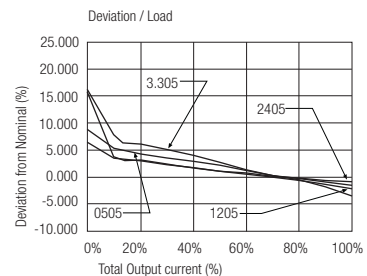
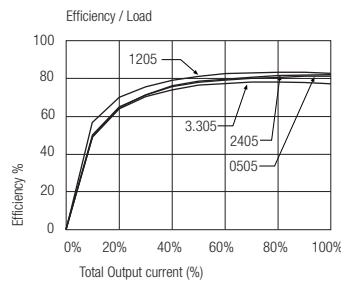

R2D-xx05

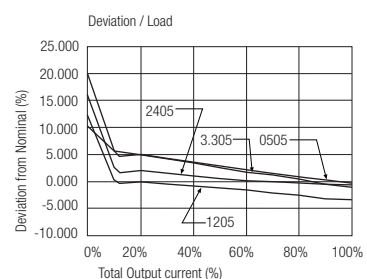
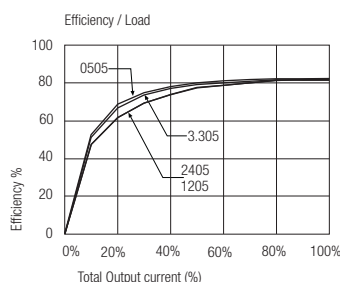

EMC Filtering - Suggestion for EN55022 Class B (Conducted and Emitted)

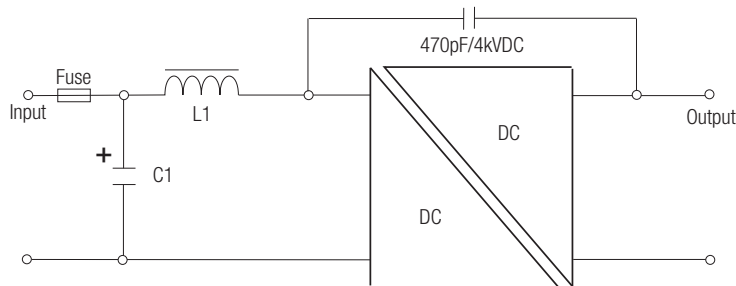

Standard and /H versions

C1	L1	Vin
2.2µF	4.7µH	5V
2.2µF	10µH	12V
2.2µF	22µH	15V
4.7µF	22µH	24V

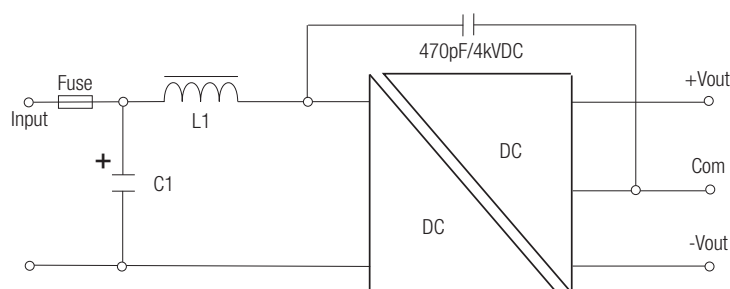

/P and /HP versions

C1	L1	Vin
10µF	10µH	5V
4.7µF	22µH	12V
4.7µF	22µH	15V
10µF	47µH	24V

C1 = MLCC

L1 = SMD Inductor

Package Style and Pinning (mm)

8 PIN Single SMD Package

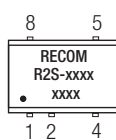
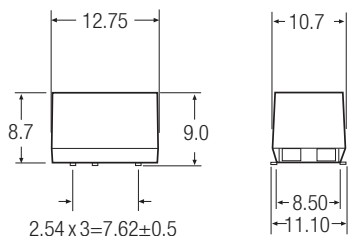

10 PIN Dual SMD Package

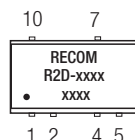
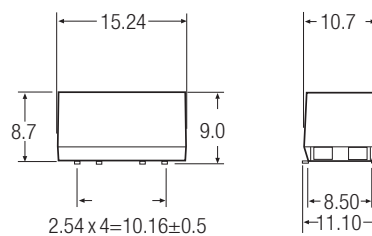

Pin Connections

Pin #	Single	Dual
1	-Vin	-Vin
2	+Vin	+Vin
4	-Vout	Com
5	+Vout	-Vout
7	No Pin	+Vout
8	NC	No Pin
10	No Pin	NC

NC = No Connection

XX.X ± 0.5 mm

XX.XX ± 0.25 mm

Recommended Footprint Details

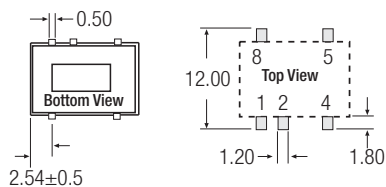

Recommended Footprint Details

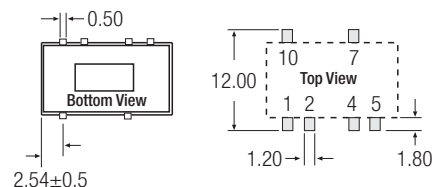

R2S** : ** without marking denotes 5 pins out of 8 fitted (includes /H option)
 ** with marking **8** denotes 8 pins out of 8 fitted (/H option not available)

R2D** : ** without marking denotes 6 pins out of 10 fitted (includes /H option)
 ** with marking **10** denotes with 10 pins out of 10 fitted (/H option not available)

e.g. R2S-0505, R2S-0505/H, R2S-0505/HP
 e.g. R2S8-0505, R2S8-0505/P

e.g. R2D-0505, R2D-0505/H, R2D-0505/HP
 e.g. R2D10-0505, R2D10-0505/P

Package Style and Pinning (mm)

Full 8 PIN Single SMD Package

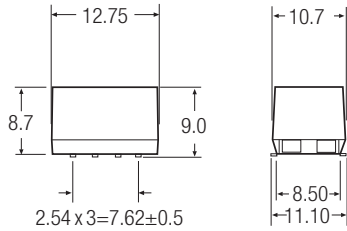

Note: /H option is not available in these pin packages

Full 10 PIN Dual SMD Package

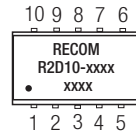
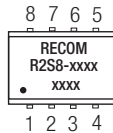
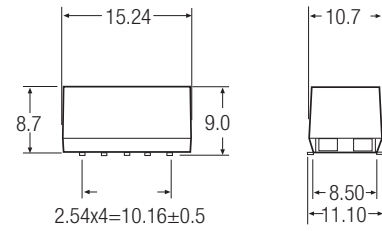

Pin Connections

Pin #	Single	Dual
1	-Vin	-Vin
2	+Vin	+Vin
3	NC	NC
4	-Vout	Com
5	+Vout	-Vout
6	NC	NC
7	NC	+Vout
8	NC	NC
9	-	NC
10	-	NC

NC = No Connection

XX.X ± 0.5 mm
XX.XX ± 0.25 mm

Recommended Footprint Details

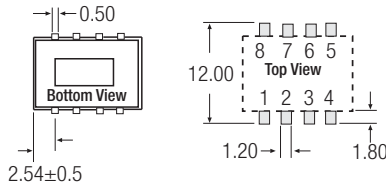

Recommended Footprint Details

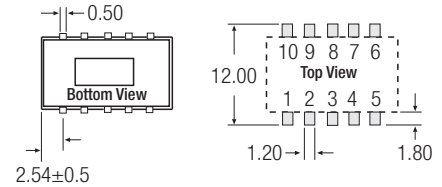

12 PIN Single and Dual SMD Package

Note: /H option is available in this pin package

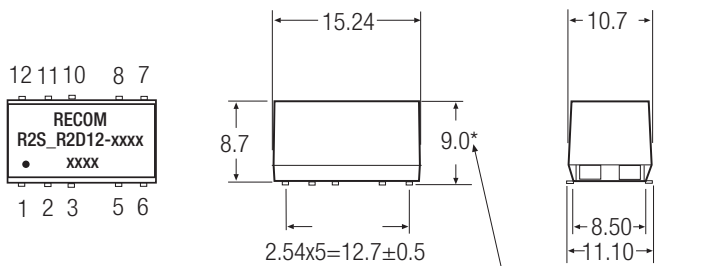

Pin Connections

Pin #	Single	Dual
1	-Vin	-Vin
2	+Vin	+Vin
3	NC	NC
5	-Vout	Com
6	NC	-Vout
7	NC	NC
8	+Vout	+Vout
10	NC	NC
11	NC	NC
12	NC	NC

NC = No Connection

XX.X ± 0.5 mm
XX.XX ± 0.25 mm

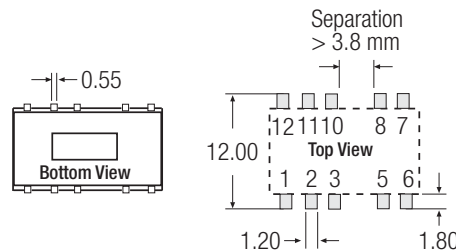

Recommended Footprint Details

R2S** : ** with marking 12 denotes 10 pins out of 12 fitted (includes /H option)
R2D** : ** with marking 12 denotes 10 pins out of 12 fitted (includes /H option)

e.g. R2S12-0505, R2S12-0505/H, R2S12-0505/HP
e.g. R2D12-0505, R2D12-0505/H, R2D12-0505/HP

Features

Unregulated Converters

- Custom Solutions Available
- 1kVDC Isolation
- No External Components Required
- Optional Continuous Short Circuit Protected
- UL94V-0 Package Material
- No Heatsink Required
- Efficiency to 85%

Description

The RI series has been specifically designed for applications where board space is at a premium since these 2 Watt converters have only a slightly larger foot print than the RO series 1 Watt converters. With efficiencies up to 87%, the full output power is available over the operating temperature range -40°C to +85°C and the converters can be used in ambient temperatures of up to 100°C with derating. The wide selection of input voltage and output voltage options plus an I/O-Isolation of 1kVDC as standard makes these converters suitable for many industrial applications.

Selection Guide

Part Number SIP4	Input Voltage (VDC)	Output Voltage (VDC)	Output Current (mA)	Efficiency (%)	Max Capacitive Load ⁽¹⁾
RI-xx05S	5, 12, 15, 24	5	400	78-83	1200µF
RI-xx12S	5, 12, 15, 24	12	167	80-85	680µF
RI-xx15S	5, 12, 15, 24	15	133	80-85	680µF

xx = Input Voltage. Other input and output voltage combinations available on request.

* add Suffix "P" for Continuous Short Circuit Protection, e.g. RI-0505S/P

Specifications (measured at T_A = 25°C, nominal input voltage, full load and after warm-up)

Input Voltage Range		±10%
Output Voltage Accuracy		±5%
Line Voltage Regulation		1.2%/1% of V _{in} typ.
Load Voltage Regulation	5V Output types	15% max.
(10% to 100% full load)	All others	10% max.
Output Ripple and Noise (20MHz limited)		200mVp-p max.
Operating Frequency		35kHz min. / 50kHz typ. / 85kHz max.
Efficiency at Full Load		70% min. / 80% typ.
Minimum Load = 0%	Specifications valid for 10% minimum load only.	
Isolation Voltage	(tested for 1 second)	1000VDC
	(rated for 1 minute)	500VAC / 60Hz
Isolation Capacitance		30pF min. / 85pF max.
Isolation Resistance		10 GΩ min.
Short Circuit Protection		1 Second
P-Suffix		Continuous
Operating Temperature Range (free air convection)		-40°C to +85°C (see Graph)
Storage Temperature Range		-55°C to +125°C
Relative Humidity		95% RH
Package Weight		1.4g
Packing Quantity		42 pcs per Tube
MTBF (+25°C)	Detailed Information see Application Notes chapter "MTBF"	using MIL-HDBK 217F
(+85°C)		using MIL-HDBK 217F
		845 x 10 ³ hours
		160 x 10 ³ hours

Certifications

EN General Safety

Report: SPCLVD1109103

EN60950-1:2006 + A12:2011

ECONOLINE

DC/DC-Converter

with 3 year Warranty

RECOM

2 Watt

SIP4

Single Output



EN-60950-1 Certified

RI

Derating-Graph

(Ambient Temperature)

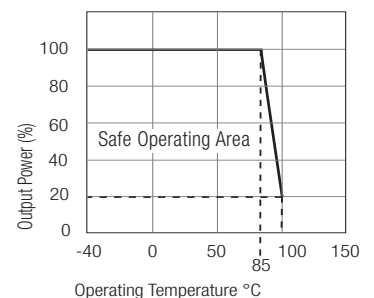

**Any data referred to in this datasheet are of indicative nature and based on our practical experience only. For further details, please refer to our Application Notes.

Refer to Application Notes

Typical Characteristics

RI-xx05S

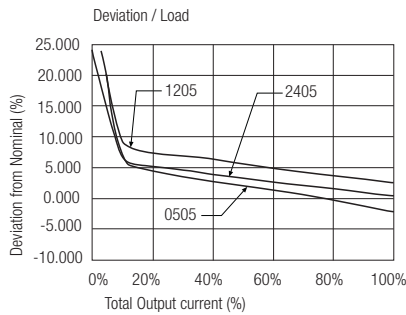
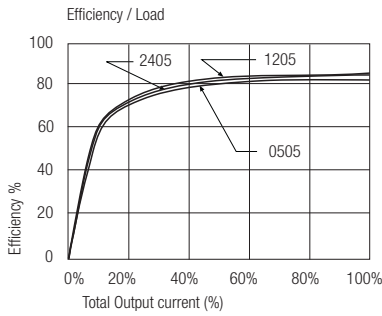

RI-xx12S

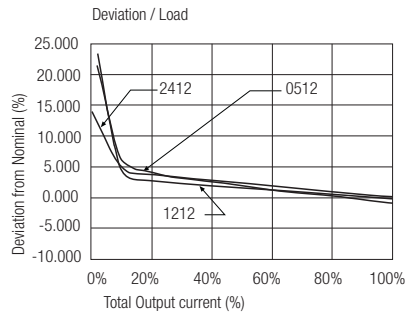
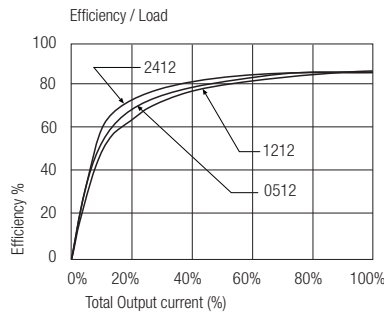

RI-xx15S

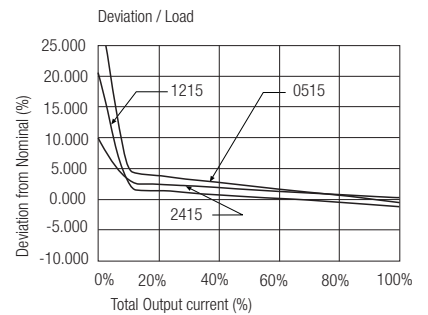
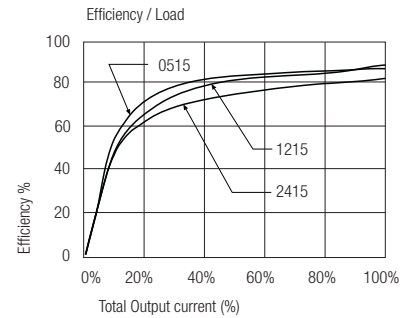

Notes
Note 1 Maximum capacitive load is defined as the capacitive load that will allow start up in under 1 second without damage to the converter.

Package Style and Pinning (mm)

4 PIN SIP Package

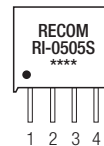
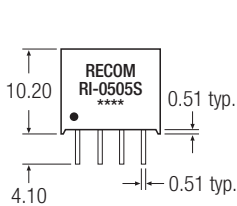

Recommended Footprint Details

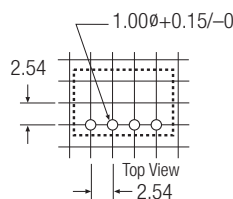
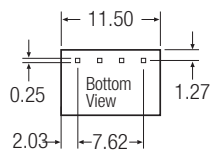

Pin Connections

Pin #	Dual
1	-Vin
2	+Vin
3	-Vout
4	+Vout
XX.X ± 0.5 mm	
XX.XX ± 0.25 mm	

Features

Unregulated Converters

- Low Cost 2W Dual Output Converter
- Industry Standard SIP7 Packages
- Power Sharing on Outputs
- Optional Continuous Short Circuit Protected
- 1kVDC and 2kVDC Isolation Options
- UL94V-0 Package Material
- Efficiency to 86 %

Description

The RD series have been specifically designed for applications where dual power rails need to be created from a single rail supply and a low cost solution is required. With efficiencies up to 85%, the full output power is available over the operating temperature range -40°C to +85°C and the converters can be used in ambient temperatures of up to 100°C with derating. The wide selection of industry standard input voltage and output voltage options plus an I/O-Isolation of 1kVDC or 2kVDC makes these converters suitable for many industrial applications.

Selection Guide

Part Number	2kV	Input Voltage (VDC)	Output Voltage (VDC)	Output Current (mA)	Efficiency (%)	Max Capacitive Load ⁽¹⁾
RD-xx05D	(H)	5, 12, 24	±5	±200	75-82	±470µF
RD-xx12D	(H)	5, 12, 24	±12	±84	80-84	±330µF
RD-xx15D	(H)	5, 12, 24	±15	±66	82-86	±330µF
RD-xx24D	(H)	5, 12, 24	±24	±42	82-86	±100µF

xx = Input Voltage. Other input and output voltage combinations available on request.

* add Suffix "P" for Continuous Short Circuit Protection, e.g. RD-0505D/P, RD-0505D/HP

Specifications (measured at T_A = 25°C, nominal input voltage, full load and after warm-up)

Input Voltage Range			±10%
Output Voltage Accuracy			±5%
Line Voltage Regulation			1.2%/1% of Vin typ.
Load Voltage Regulation (10% to 100% full load)	3.3V output types		20% max.
	5V output type		15% max.
	9V, 12V, 15V, 24V output types		10% max.
Output Ripple and Noise (20MHz limited)			150mVp-p max.
Operating Frequency			34kHz min. / 50kHz typ. / 85kHz max.
Efficiency at Full Load			70% min. / 80% typ.
Minimum Load = 0%	Specifications valid for 10% minimum load only.		
Isolation Voltage	(tested for 1 second)		1000VDC
	(rated for 1 minute**)		500VAC / 60Hz
Isolation Voltage	H-Suffix	(tested for 1 second)	2000VDC
	H-Suffix	(rated for 1 minute**)	1000VAC / 60Hz
Isolation Capacitance			40pF min. / 115pF max.
Isolation Resistance			10 GΩ min.
Short Circuit Protection			1 Second
P-Suffix			Continuous
Operating Temperature Range (free air convection)			-40°C to +85°C (see Graph)
Storage Temperature Range			-55°C to +125°C
Relative Humidity			95% RH
Package Weight			2.8g
Packing Quantity			25 pcs per Tube
MTBF (+25°C)	} Detailed Information see Application Notes chapter "MTBF"	using MIL-HDBK 217F	988 x 10 ³ hours
		using MIL-HDBK 217F	135 x 10 ³ hours

Certifications

EN General Safety Report: SPCLVD1109103 EN60950-1:2006 + A12:2011

ECONOLINE

DC/DC-Converter

with 3 year Warranty

RECOM

2 Watt

SIP7

Dual Output



EN-60950-1 Certified

RD

Derating-Graph (Ambient Temperature)

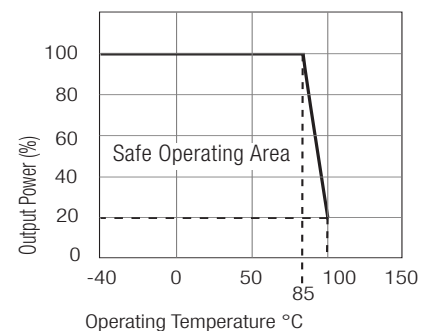

**Any data referred to in this datasheet are of indicative nature and based on our practical experience only. For further details, please refer to our Application Notes.

Refer to Application Notes

Typical Characteristics

RD-xx05D

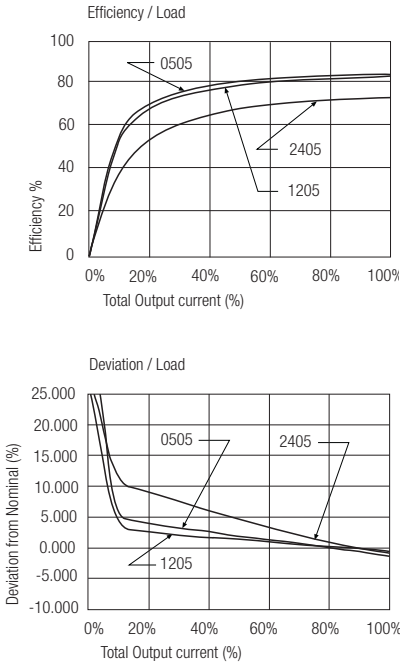

RD-xx12D

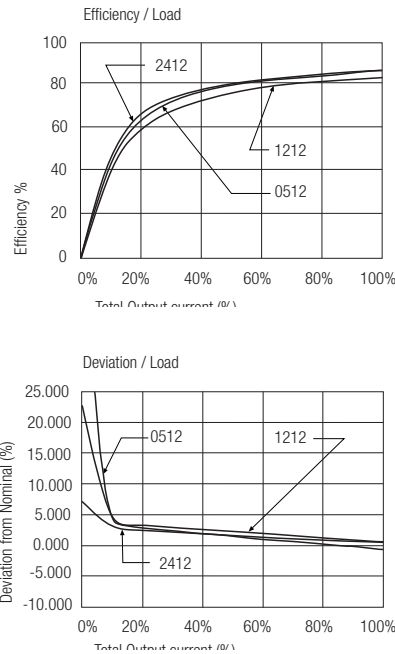

RD-xx15D

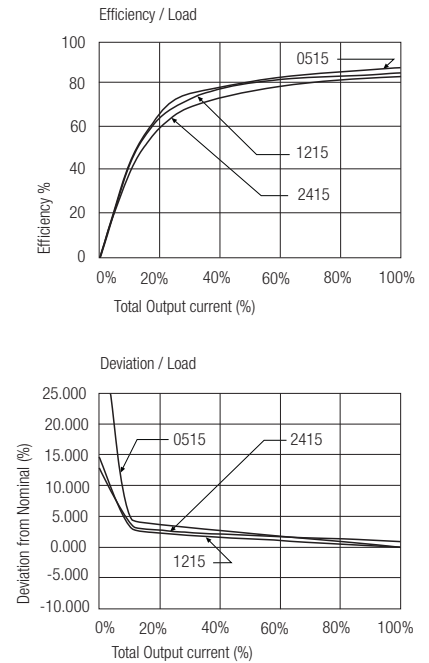

Notes

Note 1 Maximum capacitive load is defined as the capacitive load that will allow start up in under 1 second without damage to the converter.

RD

Package Style and Pinning (mm)

7 PIN SIP Package

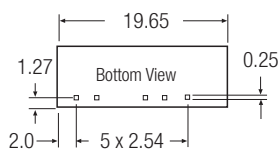
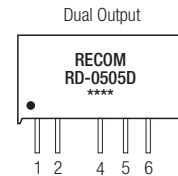
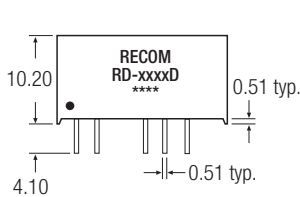

Recommended Footprint Details

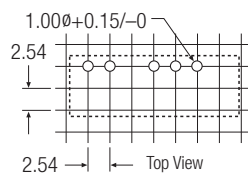

Pin Connections

Pin #	RD
1	+Vin
2	-Vin
4	-Vout
5	Com
6	+Vout

XX.X ± 0.5 mm
XX.XX ± 0.25 mm

Features

Unregulated Converters

- High Isolation 2W Converter
- Approved for Medical Applications
- Custom Solutions Available
- 3kVDC and 4kVDC Isolation Options
- UL94V-0 Package Material
- Optional Continuous Short Circuit Protected
- Efficiency to 84%
- Suitable for IGBT Applications

Description The RKZ Series of 2W DC/DC Converters are certified to EN 60950-1 and to the medical standard EN-60601-1. This makes them suitable for high end industrial applications such as IGBT driver circuitry as well as standard medical applications. The RUZ converters are pin-compatible with the RK and RH converter series, offering a simple way to upgrade a 1W high isolation supply to 2W.

Selection Guide

Part Number	4kV	Input Voltage (VDC)	Output Voltage (VDC)	Output Current (mA)	Efficiency (%)	Max Capacitive Load ⁽¹⁾
RKZ-xx05S*	(H)	5, 12	5	400	82-84	1200µF
RKZ-xx12S*	(H)	5, 12	12	168	82-84	680µF
RKZ-xx15S*	(H)	5, 12	15	132	82-84	680µF
RKZ-xx05D*	(H)	5, 12	±5	±200	70-82	±470µF
RKZ-xx12D*	(H)	5, 12	±12	±84	82-84	±220µF
RKZ-xx15D*	(H)	5, 12	±15	±66	82-84	±220µF
RKZ-xx1509D*	(H)	5, 12, 24	+15/-9	+67/-111	70-81	±330µF

xx = Input Voltage. Other input and output voltage combinations available on request.

* add Suffix "P" for Continuous Short Circuit Protection, e.g. RKZ-0515D/P, e.g. RKZ-0515D/HP has 4kV Isolation and is Short Circuit Protected.

Specifications (measured at T_A = 25°C, nominal input voltage, full load and after warm-up)

Input Voltage Range		±10%
Output Voltage Accuracy		±5%
Line Voltage Regulation		1.2%/1% of Vin typ.
Load Voltage Regulation (10% to 100% load)	5V type	15% max.
	Other types, RKZ-xx1509D	10% max.
Output Ripple and Noise (20MHz limited)		150mVp-p max.
Operating Frequency	35kHz min. / 50kHz typ. / 85kHz max.	
	RKZ-xx1509D	20kHz min. / 51kHz typ.
Efficiency at Full Load		70% min. / 80% typ.
Minimum Load = 0%	Specifications valid for 10% minimum load only.	
Isolation Voltage	(tested for 1 second)	3000VDC
	(rated for 1 minute**)	1500VAC / 60Hz
Isolation Voltage	H-Suffix (tested for 1 second)	4000VDC
	H-Suffix (rated for 1 minute**)	2000VAC / 60Hz
Isolation Capacitance		30pF min. / 110pF max.
Isolation Resistance		15 GΩ min.
Short Circuit Protection		1 sec
Operating Temperature Range (free air convection, without derating)	-40°C to +90°C (see Graph)	
Storage Temperature Range	-55°C to +125°C	
Relative Humidity	95% RH	
Package Weight	2.8g	
Packing Quantity	25 pcs per Tube	
MTBF (+25°C)	Detailed Information see Application Notes chapter "MTBF"	using MIL-HDBK 217F
(+85°C)		using MIL-HDBK 217F
		988 x 10 ³ hours
		135 x 10 ³ hours

continued on next page

ECONOLINE

DC/DC-Converter

with 3 year Warranty

RECOM

2 Watt

SIP7

Single & Dual Output



EN-60950-1 Certified
IEC/EN-60601-1 Certified*
 * +15/-9 Version excluded

RKZ

Derating-Graph (Ambient Temperature)

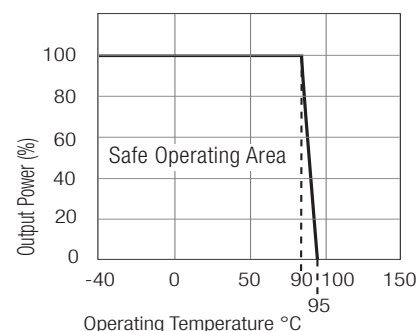

**Any data referred to in this datasheet are of indicative nature and based on our practical experience only. For further details, please refer to our Application Notes.

Refer to Application Notes

Specifications (measured at $T_A = 25^\circ\text{C}$, nominal input voltage, full load and after warm-up)

Certifications

EN General Safety
EN Medical safety

Report: SPCLVD1109103
Report: SPCMDD1205098-4

EN60950-1:2006 + A12:2011
IEC/EN 60601-1:2006, 3rd Edition

Notes

Note 1 Maximum capacitive load is defined as the capacitive load that will allow start up in under 1 second without damage to the converter.

Typical Characteristics

RKZ-xx05S

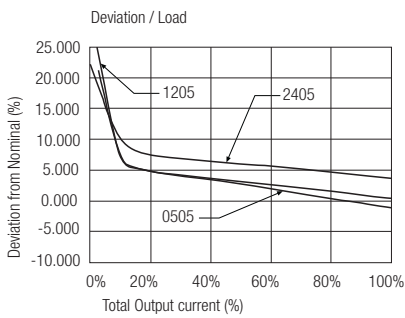
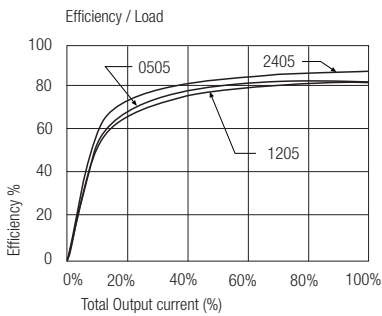

RKZ-xx12S

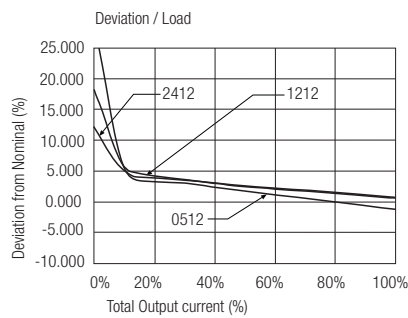
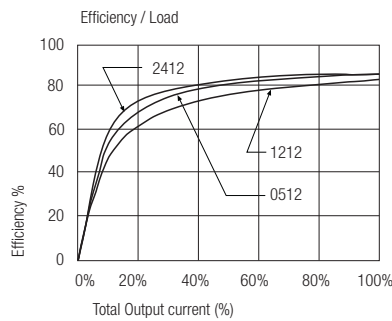

RKZ-xx15S

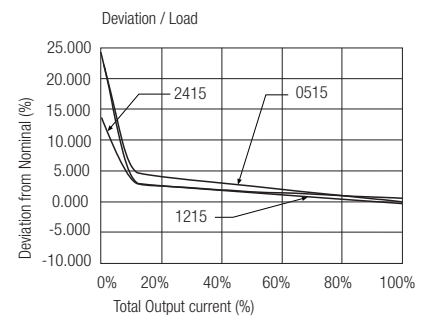
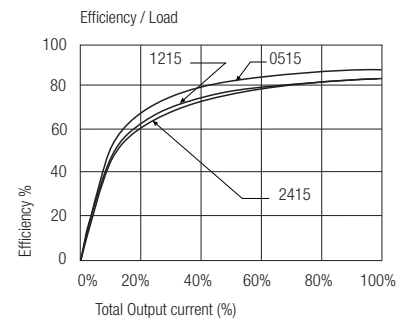

RKZ-xx05D

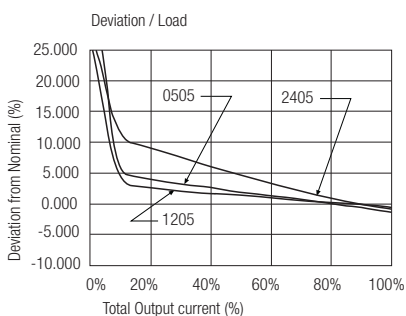
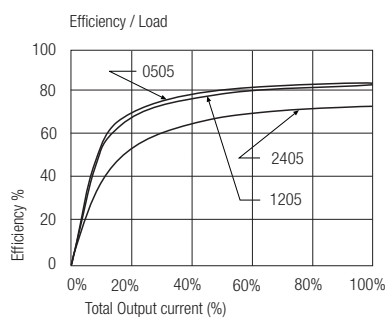

RKZ-xx12D

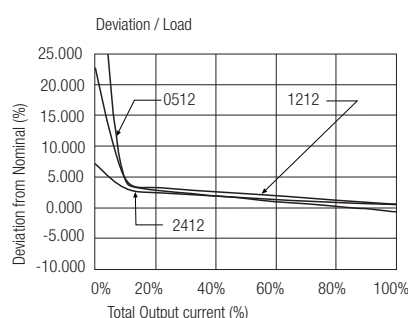
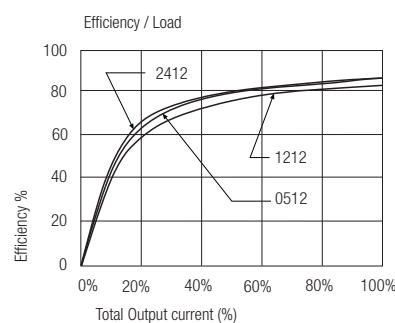

RKZ-xx15D

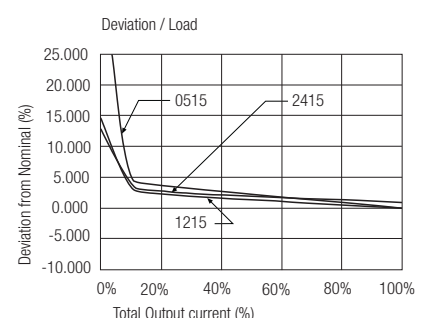
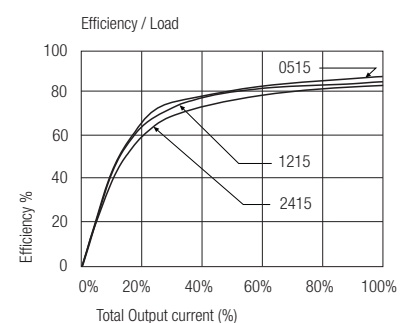

Application

IGBT Application Circuit

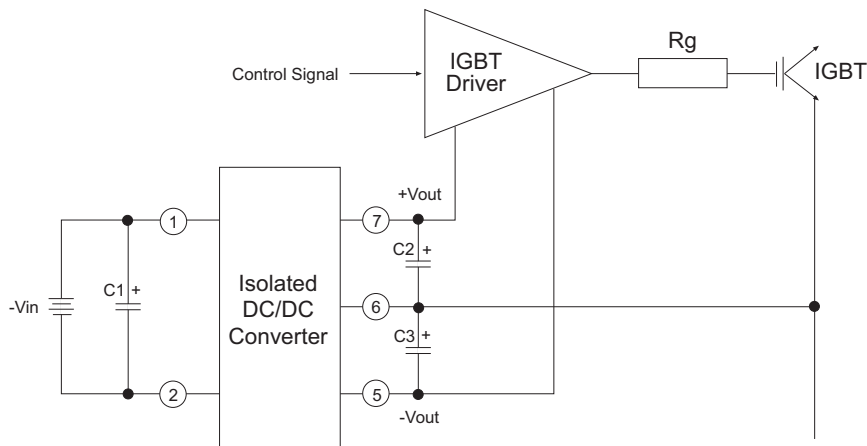

Package Style and Pinning (mm)

7 PIN SIP Package

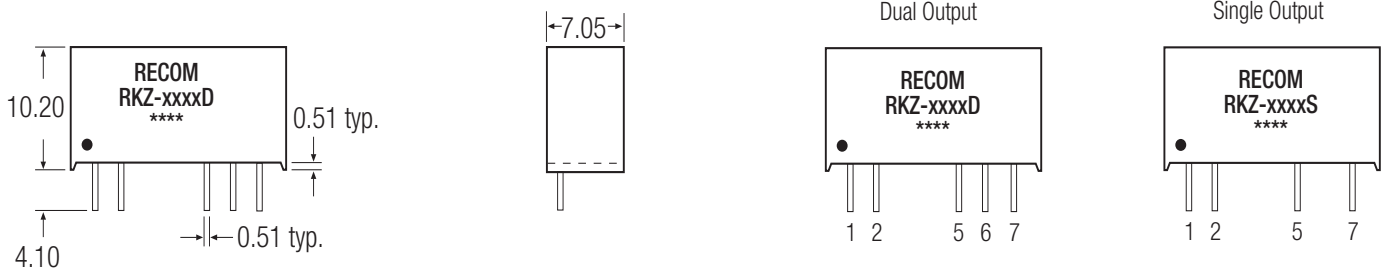

Recommended Footprint Details

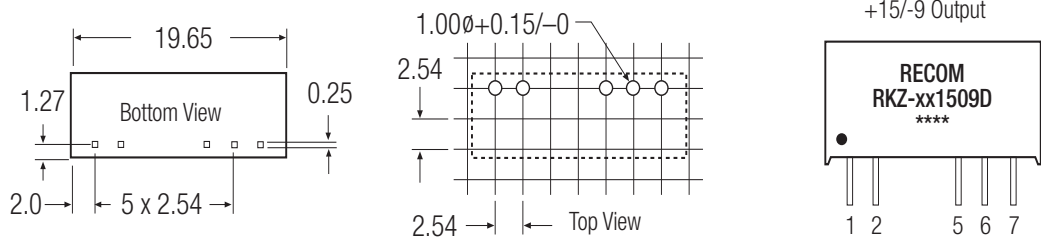

Pin Connections

Pin #	Single	Dual
1	+Vin	+Vin
2	-Vin	-Vin
5	-Vout	-Vout
6	No Pin	Com
7	+Vout	+Vout

NC = No Connection
XX.X ± 0.5 mm
XX.XX ± 0.25 mm

The product information and specifications are subject to change without prior notice. All products are designed for non-safety critical commercial and industrial applications. The Buyer agrees to implement safeguards that anticipate the consequences of any failures that might cause harm, loss of life and/or damage property.

Features

Unregulated Converters

- UL/CSA and EN Safety certified
- EN-60601 for Medical Applications
- Isolation 6.4kVDC
- Optional Continuous Short Circuit Protected
- Unique Transformer System
- Compact SIP7 Package
- /X2 Version with >9mm Input/Output Clearance
- Suitable for IGBT Applications
- Very Low Isolation Capacitance

Description

The RxxP2xxS_D Series of DC/DC Converters are certified to UL/CSA-60950 and UL/CSA 60601 as well as EN-60950 and EN60601. This makes them ideal for medical and safety applications where approved isolation is required. The /X2 version has an input/output clearance of more than 9mm.

Selection Guide

Part Number SIP 7	Input Voltage (VDC)	Output Voltage (VDC)	Output Current (mA)	Efficiency Std (%)	Max Capacitive Load ⁽¹⁾
RxxP23.3S*	5, 12, 15, 24	3.3	600	70	3300µF
RxxP205S*	5, 12, 15, 24	5	400	70-75	1200µF
RxxP209S*	5, 12, 15, 24	9	222	70-75	1200µF
RxxP212S*	5, 12, 15, 24	12	167	70-75	680µF
RxxP215S*	5, 12, 15, 24	15	132	75-80	680µF
RxxP23.3D*	5, 12, 15, 24	±3.3	±300	70	±1500µF
RxxP205D*	5, 12, 15, 24	±5	±200	70-75	±470µF
RxxP209D*	5, 12, 15, 24	±9	±111	70-75	±470µF
RxxP212D*	5, 12, 15, 24	±12	±85	70-75	±330µF
RxxP215D*	5, 12, 15, 24	±15	±66	75-80	±330µF
RxxP21509D*	5, 12, 24	+15/-9	+67/-111	70-82	±330µF

xx = Input Voltage. Other input and output voltage combinations available on request.

* add Suffix "P" for Continuous Short Circuit Protection, e.g. R05P205S/P, R05P205D/P

* add Suffix "/X2" for single output with alternative pinout, e.g. R05P205S/X2, R05P205S/P/X2

Specifications (measured at $T_A = 25^\circ\text{C}$, nominal input voltage, full load and after warm-up)

Input Voltage Range	±10%	
Output Voltage Accuracy	±5%	
Line Voltage Regulation	1.2%/1% of V_{in} typ.	
Load Voltage Regulation (10% to 100% full load)	3.3, 5V output types	15% max.
	other output types, RxxP21509D	10% max.
Output Ripple and Noise (20MHz BW)	200mVp-p max.	
Operating Frequency	20kHz min. / 50kHz typ. / 85kHz max.	
	RxxP21509D	20kHz min. / 50kHz typ.
Efficiency at Full Load	65% min. / 80% max.	
Minimum Load = 0%	Specifications valid for 10% minimum load only.	
Isolation Voltage	(tested for 1 second)	6400VDC
	(rated for 1 minute**)	3200VAC / 60Hz
Isolation Capacitance	1.5pF min / 10pF max.	
Isolation Resistance	15 GΩ min.	
Short Circuit Protection	1 Second	
P-Suffix	Continuous	

continued on next page

**Any data referred to in this datasheet are of indicative nature and based on our practical experience only. For further details, please refer to our Application Notes.

ECONOLINE

DC/DC-Converter

with 3 year Warranty

RECOM

2 Watt

SIP 7 Single & Dual Output



EN-60950-1 Certified
IEC/EN-60601-1 Certified*
UL/CSA 60950-1 Certified*
 * +15/-9 Version excluded

RxxP2xx

Derating-Graph (Ambient Temperature)

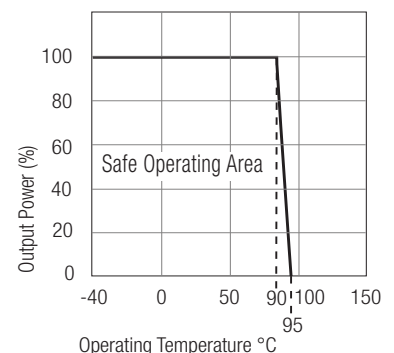

Refer to Application Notes

Specifications (measured at $T_A = 25^\circ\text{C}$, nominal input voltage, full load and after warm-up)

Operating Temperature Range (free air convection, without derating)	-40°C to +90°C (see Graph)		
Storage Temperature Range	-55°C to +125°C		
Relative Humidity	95% RH		
Package Weight	4.3g		
Packing Quantity	25 pcs per Tube		
MTBF (+25°C)	Detailed Information see Application Notes chapter "MTBF"	Single/Dual using MIL-HDBK 217F	2113/2434 x 10 ³ hours
(+85°C)		Single/Dual using MIL-HDBK 217F	299/334 x 10 ³ hours
Certifications			
UL/cUL General Safety	Report: E358085	UL 60950-1 2nd Ed.	
EN General Safety	Report: SPCLVD1109103	EN60950-1:2006 + A12: 2011	
EN Medical Safety	Report: SPCMDD1205098-4	IEC/EN60601-1:2006, 3rd Edition	

Notes

Note 1 Maximum capacitive load is defined as the capacitive load that will allow start up in under 1 second without damage to the converter.

Tolerance Envelope

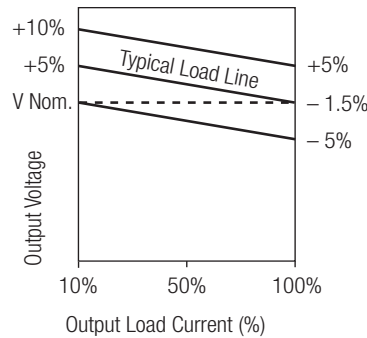

Typical Characteristics

RxxP205S
RxxP209S

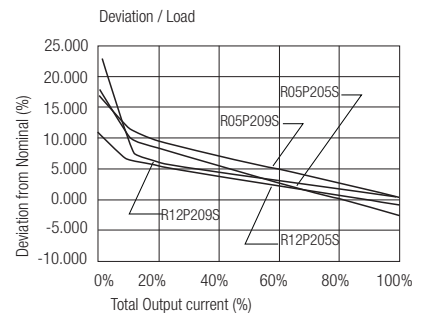
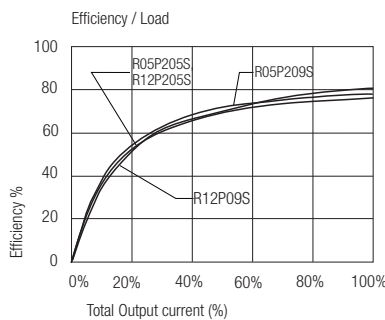

R05P205D
R05P209D

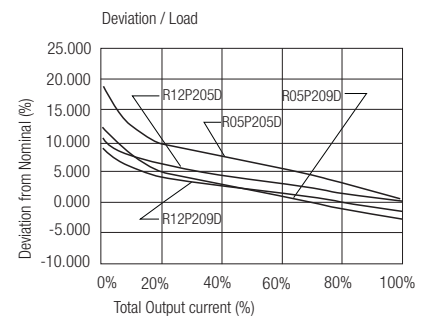
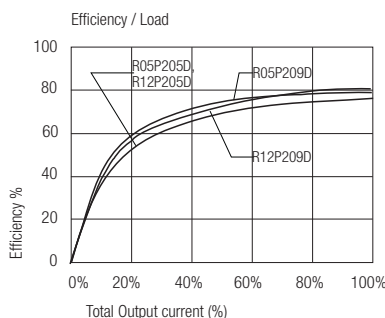

Typical Characteristics

RxxP212S RxxP215S

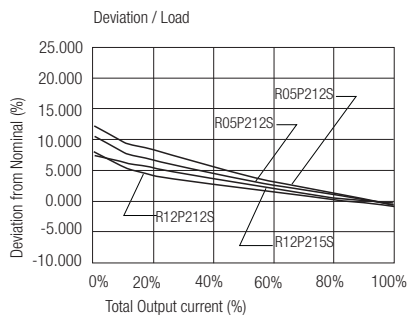
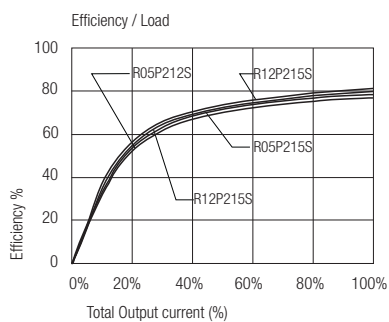

RxxP212D RxxP215D

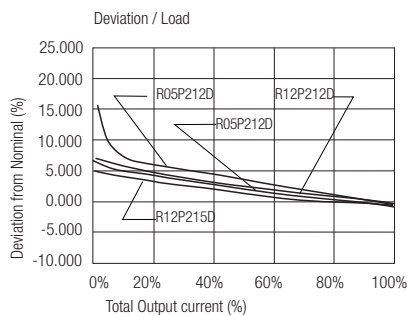
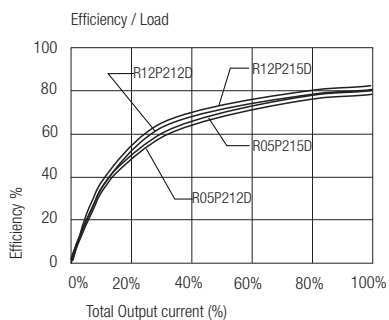

RxxP2xx

Application

IGBT Application Circuit

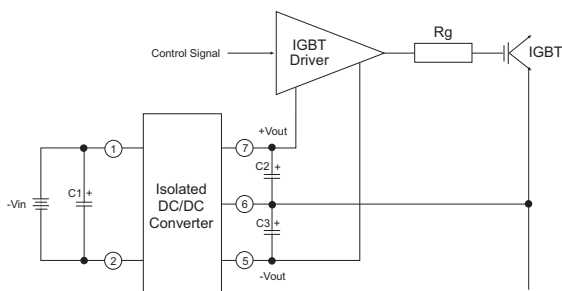

Package Style and Pinning (mm)

7 PIN SIP Package

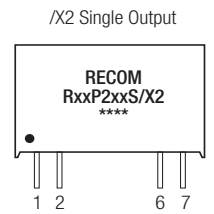
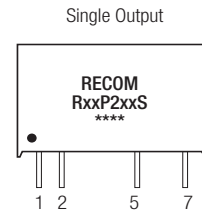
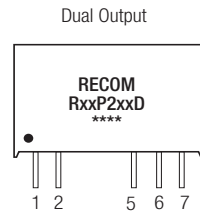
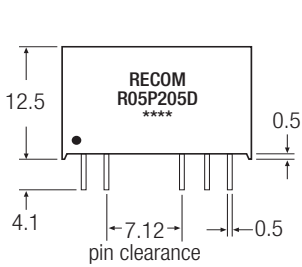

Recommended Footprint Details

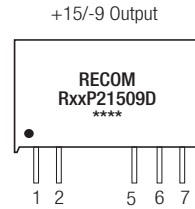
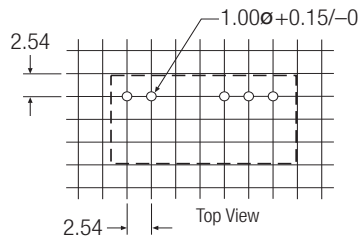
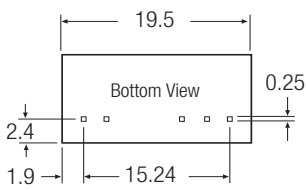

Pin Connections

Pin #	Single	Dual	/X2
1	+Vin	+Vin	+Vin
2	-Vin	-Vin	-Vin
5	-Vout	-Vout	No Pin
6	No Pin	Com	-Vout
7	+Vout	+Vout	+Vout

XX.X ± 0.5 mm
XX.XX ± 0.25 mm

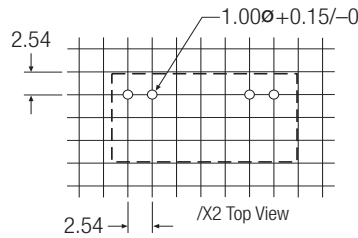
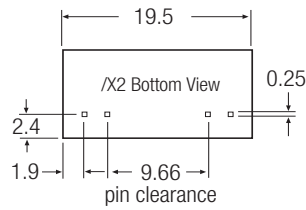

RxxP2xx

The product information and specifications are subject to change without prior notice. All products are designed for non-safety critical commercial and industrial applications. The Buyer agrees to implement safeguards that anticipate the consequences of any failures that might cause harm, loss of life and/or damage property.

Features

Unregulated Converters

- UL/CSA and EN Safety certified
- EN-61010 for Test, Measurement and Lab Use
- EN-60601 for Medical Applications
- Reinforced Isolation 6.4kVDC or 8kVDC
- Optional Continuous Short Circuit Protected
- Compact SIP7 Package
- Efficiency to 88%
- Very Low Isolation Capacitance
- /X2 Version with >9mm Input/Output Clearance

Description

The RxxP2xxS_D Series of DC/DC Converters are certified to UL/CSA-60950 and UL/CSA 60601. This makes them ideal for medical and safety applications where approved or reinforced isolation is required. The reinforced versions are also EN61010-1 certified for Lab Equipment. The /X2 version has an input/output clearance of more than 9mm.

Selection Guide

Part Number SIP 7	Reinforced Isolation (kVDC)	Input Voltage (VDC)	Output Voltage (VDC)	Output Current (mA)	Efficiency Std (%)	Max Capacitive Load ⁽¹⁾
RxxP23.3S	/R6.4 & /R8	5, 12, 15, 24	3.3	600	72-78	3300µF
RxxP205S	/R6.4 & /R8	5, 12, 15, 24	5	400	79-84	1200µF
RxxP209S	/R6.4 & /R8	5, 12, 15, 24	9	222	80-87	1200µF
RxxP212S	/R6.4 & /R8	5, 12, 15, 24	12	167	80-87	680µF
RxxP215S	/R6.4 & /R8	5, 12, 15, 24	15	132	80-88	680µF
RxxP23.3D	/R6.4 & /R8	5, 12, 15, 24	±3.3	±300	73-80	±1500µF
RxxP205D	/R6.4 & /R8	5, 12, 15, 24	±5	±200	79-85	±470µF
RxxP209D	/R6.4 & /R8	5, 12, 15, 24	±9	±111	80-87	±470µF
RxxP212D	/R6.4 & /R8	5, 12, 15, 24	±12	±85	80-87	±330µF
RxxP215D	/R6.4 & /R8	5, 12, 15, 24	±15	±66	80-88	±330µF

xx = Input Voltage. Other input and output voltage combinations available on request.

* add Suffix "P" for Continuous Short Circuit Protection, e.g. R05P205S/P, R05P205D/P

* add Suffix "/X2" for single output with alternative pinout, e.g. R05P205S/X2, R05P205S/P/X2

* add Suffix "/R6.4" or "/R8" for Reinforced Isolation, e.g. R05P205D/R6.4, R05P205S/P/X2/R8

Specifications (measured at T_A = 25°C, nominal input voltage, full load and after warm-up)

Input Voltage Range		±10%
Output Voltage Accuracy		±5%
Line Voltage Regulation		1.2%/1% of Vin typ.
Load Voltage Regulation	3.3, 5V output types	15% max.
(10% to 100% full load)	other output types	10% max.
Output Ripple and Noise (20MHz BW)		200mVp-p max.
Operating Frequency		20kHz min. / 50kHz typ. / 85kHz max.
Efficiency at Full Load		65% min. / 80% max.
Minimum Load = 0%		Specifications valid for 10% minimum load only.
Isolation Voltage	/R6.4 (tested for 1 second)	6400VDC
	(rated for 1 minute**)	3200VAC / 60Hz
	/R8 (tested for 1 second)	8000VDC
	(rated for 1 minute**)	4000VAC / 60Hz
Isolation Capacitance		1.5pF min. / 10pF max.
Isolation Resistance		15 GΩ min.
Short Circuit Protection		1 Second
P-Suffix		Continuous

continued on next page

**Any data referred to in this datasheet are of indicative nature and based on our practical experience only. For further details, please refer to our Application Notes.

ECONOLINE

DC/DC-Converter

with 3 year Warranty

RECOM

2 Watt

SIP 7 Single & Dual Output



E-224736 C US

- EN-60950-1 Certified
- EN-60601-1 Certified
- UL/CSA 60950-1 Certified
- UL-60601 Certified
- EN-61010-1 Certified
- IEC-60601-1 CB Report

RxxP2xx/R

Derating-Graph (Ambient Temperature)

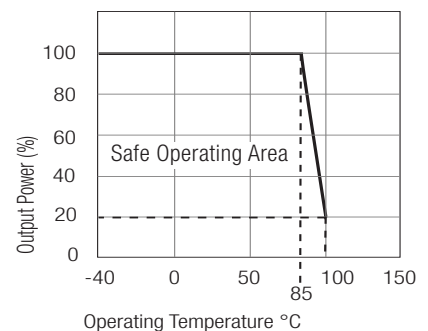

Refer to Application Notes

Specifications (measured at $T_A = 25^\circ\text{C}$, nominal input voltage, full load and after warm-up)

Operating Temperature Range (free air convection)		-40°C to +85°C (see Graph)	
Storage Temperature Range		-55°C to +125°C	
Relative Humidity		95% RH	
Package Weight		4.3g	
Packing Quantity		25 pcs per Tube	
Potting Material		Silicone Rubber Compound (UL94V-0)	
MTBF (+25°C)	} Detailed Information see Application Notes chapter "MTBF"	Reinforced	1154 x 10 ³ hours
(+85°C)			168 x 10 ³ hours
Reinforced Isolation	Transformer Creepage	/R6.4 Types	5.5 mm min.
	Transformer Clearance	/R6.4 Types	5.5 mm min.
	PCB Creepage & Clearance	/R6.4 Types	4.6 mm min.
Certifications			
Measurement, Control and Laboratory Use Safety		Report: T1301251-313	EN 61010-1 : 2010
CSA General Safety			UL 60950-1 1st Edition
UL/cUL Medical Safety		Report: E314885-A5	C22.2 No. 60950-1-03
CSA Medical Safety		Report: 2207629	UL60601-1 3rd Edition
EN General Safety		Report: SPCLVD1310079-1	CAN/CSA-22.2 No 601.1-M90
CB/EN Medical Safety		Report: CA-10169-A1-UL	EN60950-1 : 2006
			IEC/EN 60601-1 3rd Edition

Notes

Note 1 Maximum capacitive load is defined as the capacitive load that will allow start up in under 1 second without damage to the converter.

Tolerance Envelope

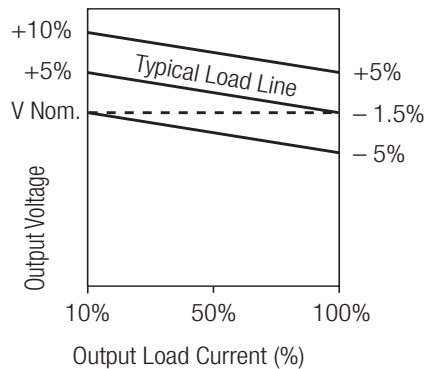

**RxxP205S/R6.4
RxxP205S/R8**

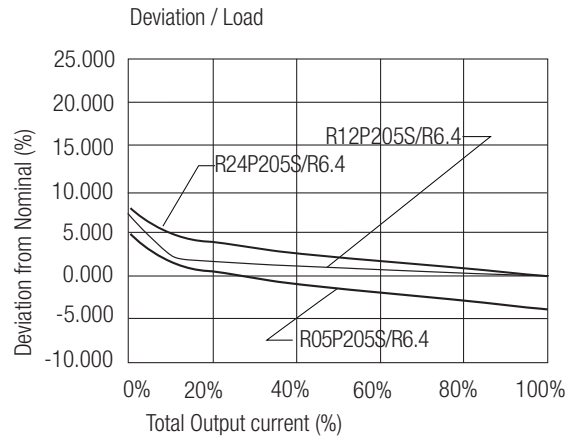
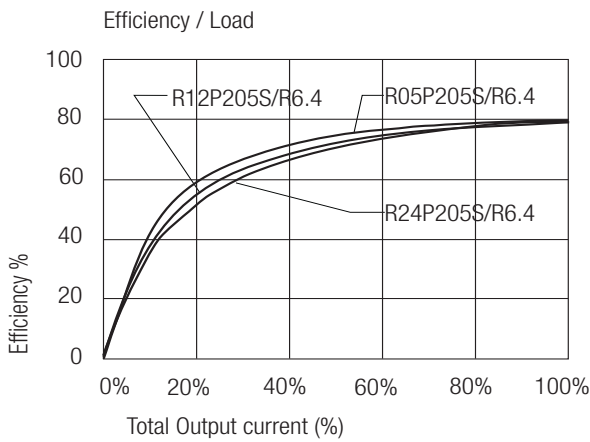

**RxxP205D/R6.4
RxxP205D/R8**

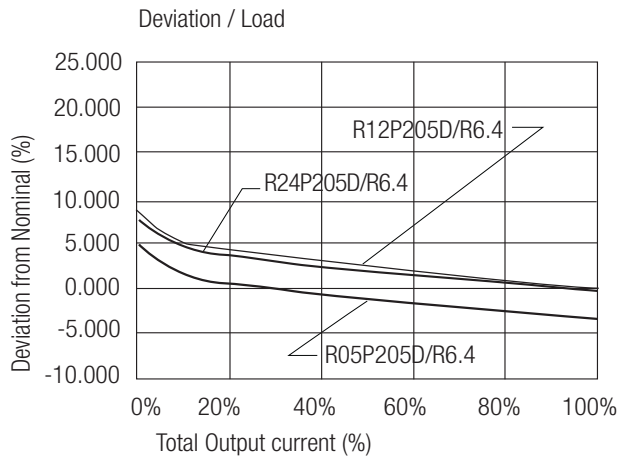
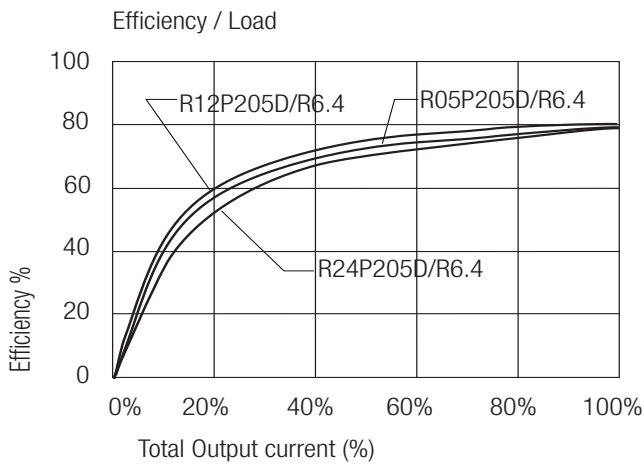

Package Style and Pinning (mm)

7 PIN SIP Package

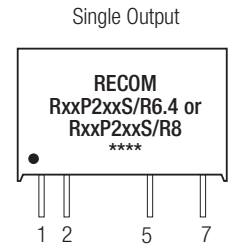
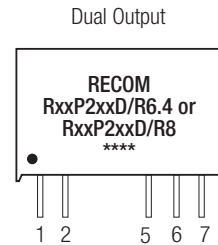
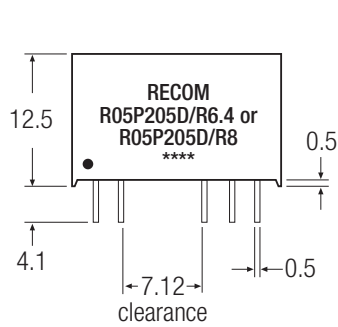

Recommended Footprint Details

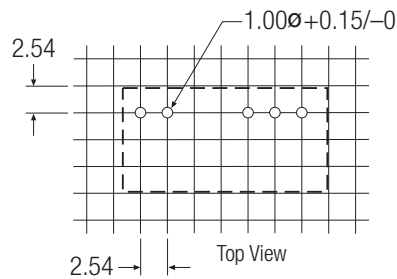
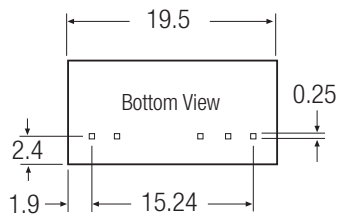

/X2 Single Output

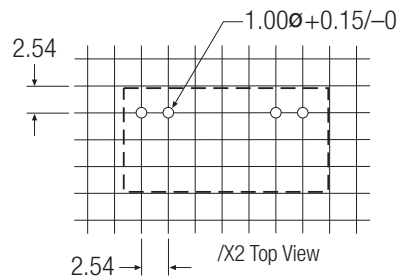
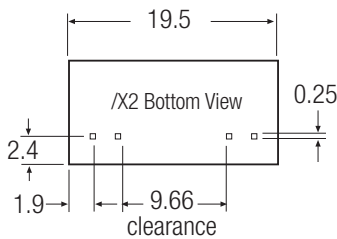
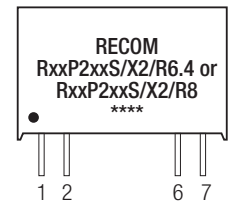

Pin Connections

Pin #	Single	Dual	/X2
1	+Vin	+Vin	+Vin
2	-Vin	-Vin	-Vin
5	-Vout	-Vout	No Pin
6	No Pin	Com	-Vout
7	+Vout	+Vout	+Vout

XX.X ± 0.5 mm

XX.XX ± 0.25 mm

Features

Unregulated Converters

- Dual Output from a Single Input Rail
- Input/Output Isolation 1kVDC or 2kVDC
- Output/Output Isolation 1kVDC
- Power Sharing on Outputs
- UL94V-0 Package Material
- Optional Continuous Short Circuit Protected
- No External Components Required
- Efficiency to 85 %

Description The RUZ DC/DC converter offers two independent isolated outputs. Typical applications include multiple channel circuits where inter-channel isolation is also required. The /H option offers 2kVDC isolation between input and outputs. The /P option is with continuous short circuit protection on either or both outputs.

Selection Guide

Part Number	Input Voltage (VDC)	Output Voltage (V1VDC)	Output Voltage (V2VDC)	Output Current (mA)	Efficiency (%)	Max Capacitive Load ⁽¹⁾
RUZ-050505	(H) 5	5	5	200/200	70	470µF/470µF

xx = Input Voltage. Other input and output voltage combinations available on request.

* add Suffix "P" for Continuous Short Circuit Protection, e.g. RUZ-050505/P, RUZ-050505/HP

Specifications (measured at $T_A = 25^\circ\text{C}$, nominal input voltage, full load and after warm-up)

Input Voltage Range			±10%
Output Voltage Accuracy			±5%
Line Voltage Regulation			1.2%/1% of V_{in} typ.
Load Voltage Regulation ((10% to 100% full load)			15% max.
Output Ripple and Noise (20MHz limited)			150mVp-p max.
Operating Frequency			20kHz min. / 50kHz typ. / 85kHz max.
Efficiency at Full Load			70% min. / 80% typ.
Minimum Load = 0%			Specifications valid for 10% minimum load only.
Isolation Voltage	(tested for 1 second)		1000VDC
Input/Output and Output/Output	(rated for 1 minute**)		3200VAC / 60Hz
Isolation Voltage	H-suffix	(tested for 1 second)	2000VDC
Input/Output	H-suffix	(rated for 1 minute**)	1000VAC / 60Hz
Output/Output	(tested for 1 second)		1000VDC
Isolation Capacitance			40pF min. / 120pF max.
Isolation Resistance			10 GΩ min.
Short Circuit Protection			1 Second
P-Suffix			Continuous
Operating Temperature Range (free air convection)			-40°C to +85°C (see Graph)
Storage Temperature Range			-55°C to +125°C
Relative Humidity			95% RH
Package Weight			2.8g
Packing Quantity			25 pcs per Tube
MTBF (+25°C)	} Detailed Information see Application Notes chapter "MTBF"	using MIL-HDBK 217F	988 x 10 ³ hours
(+85°C)		using MIL-HDBK 217F	135 x 10 ³ hours
Certifications			
EN General Safety	Report: SPCLVD1109103	EN60950-1:2006 + A12:2011	

**Any data referred to in this datasheet are of indicative nature and based on our practical experience only. For further details, please refer to our Application Notes.

ECONOLINE

DC/DC-Converter

with 3 year Warranty

RECOM

2 Watt

SIP7

Isolated

Dual Output



EN-60950-1 Certified

RUZ

Derating-Graph

(Ambient Temperature)

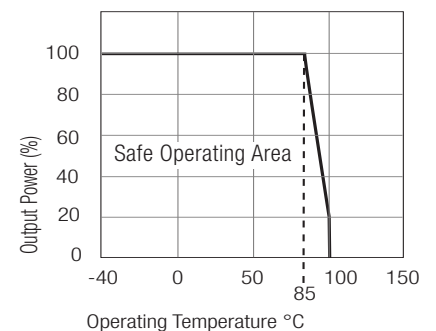

Refer to Application Notes

Typical Characteristics

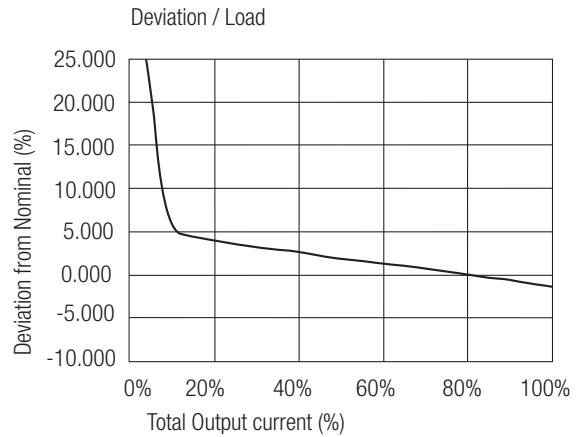
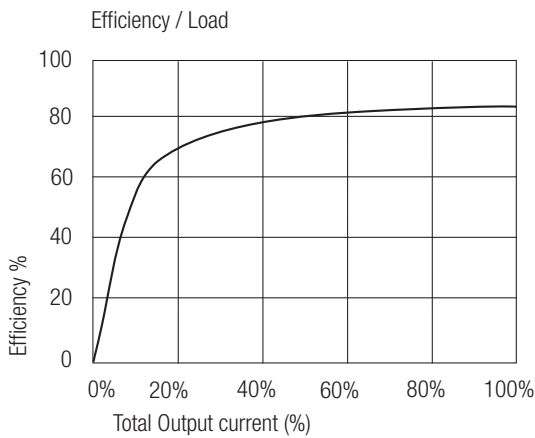

Notes

Note 1 Maximum capacitive load is defined as the capacitive load that will allow start up in under 1 second without damage to the converter.

Package Style and Pinning (mm)

7 PIN SIP Package

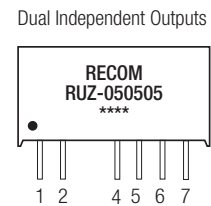
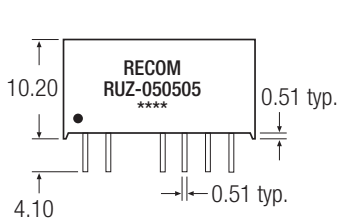

Recommended Footprint Details

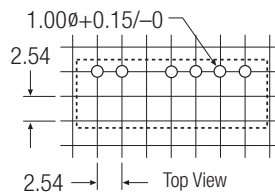
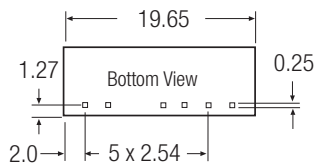

Pin Connections

Pin #	Single
1	+Vin
2	-Vin
4	+Vout 1
5	-Vout 1
6	+Vout 2
7	-Vout 2

XX.X ± 0.5 mm
XX.XX ± 0.25 mm

Typical Application

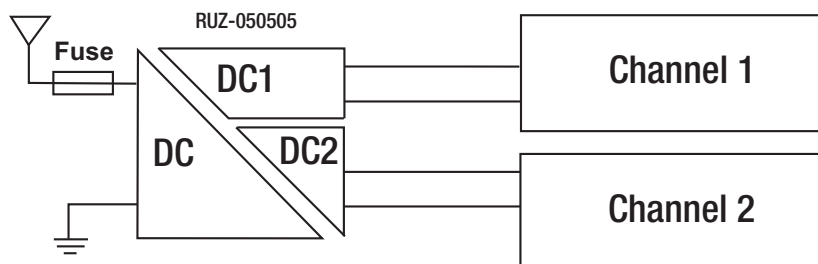

The product information and specifications are subject to change without prior notice. All products are designed for non-safety critical commercial and industrial applications. The Buyer agrees to implement safeguards that anticipate the consequences of any failures that might cause harm, loss of life and/or damage property.

Features

Unregulated Converters

- 2W Single and Dual Outputs in DIP 14
- 3kVDC or 4kVDC Isolation
- Optional Continuous Short Circuit Protected
- Custom Solutions Available
- UL94V-0 Package Material
- Efficiency up to 85 %
- Suitable for IGBT Applications

Description

The RJZ and RGZ series converters are available in DIP14 packages, so can be used for applications where component height is restricted. The wide selection of input voltage and output voltage options plus an I/O-Isolation of 3kVDC or 4kVDC as standard makes these converters suitable for many industrial, medical and IGBT applications.

Selection Guide

Part Number	Input Voltage (VDC)	Output Voltage (VDC)	Output Current (mA)	Efficiency (%)	Max Capacitive Load ⁽¹⁾
RJZ-xx3.3S*	(H) 3.3,5,9,12,15,24	3.3	606	70-75	3300µF
RJZ-xx05S*	(H) 3.3,5,9,12,15,24	5	400	78-85	1200µF
RJZ-xx09S*	(H) 3.3,5,9,12,15,24	9	222	78-84	1200µF
RJZ-xx12S*	(H) 3.3,5,9,12,15,24	12	166	80-85	680µF
RJZ-xx15S*	(H) 3.3,5,9,12,15,24	15	133	82-85	680µF
RJZ-xx24S*	(H) 3.3,5,9,12,15,24	24	83	80-85	220µF
RGZ-xx3.3D*	(H) 3.3,5,9,12,15,24	±3.3	±303	75	±1500µF
RGZ-xx05D*	(H) 3.3,5,9,12,15,24	±5	±200	75-82	±470µF
RGZ-xx09D*	(H) 3.3,5,9,12,15,24	±9	±111	75-80	±470µF
RGZ-xx12D*	(H) 3.3,5,9,12,15,24	±12	±84	78-82	±220µF
RGZ-xx15D*	(H) 3.3,5,9,12,15,24	±15	±66	80-84	±220µF
RGZ-xx24D*	(H) 3.3,5,9,12,15,24	±24	±42	82-84	±100µF
RGZ-xx1509D*	(H) 5, 12, 24	+15/-9	+67/-111	70-81	±330µF

xx = Input Voltage. Other input and output voltage combinations available on request.

* add Suffix "P" for Continuous Short Circuit Protection, e.g. RGZ-0524D/P, RJZ-0505S/HP

Specifications (measured at T_A = 25°C, nominal input voltage, full load and after warm-up)

Input Voltage Range		±10%
Output Voltage Accuracy		±5%
Line Voltage Regulation		1.2%/1% of Vin typ.
Load Voltage Regulation (10% to 100% full load)	3.3V Types	±20% max.
	5V Types	±15% max.
	All other Types, RGZ-xx1509D	±10% max.
Output Ripple and Noise (20MHz limited)		±150mVp-p max.
Temperature Coefficient		0.02%/°C max.
Operating Frequency		20kHz min. / 50kHz typ. / 90kHz max.
	RGZ-xx1509D	20kHz min. / 45kHz typ.
Efficiency at Full Load		70% min. / 80% typ.
Minimum Load = 0%		Specifications valid for 10% minimum load only.
Isolation Voltage	(tested for 1 second)	3000VDC
	(rated for 1 minute)	1500VAC / 60Hz
Isolation Voltage	H-Suffix (tested for 1 second)	4000VDC min.
	H-Suffix (rated for 1 minute)	2000VAC / 60Hz
Isolation Capacitance		120pF max.
Isolation Resistance		15GΩ min.
Short Circuit Protection		1 Second
P-Suffix		Continuous
Operating Temperature Range (free air convection, without derating)		-40°C to +90°C (see Graph)

continued on next page

ECONOLINE

DC/DC-Converter

with 3 year Warranty

RECOM

2 Watt DIP14 Single & Dual Output

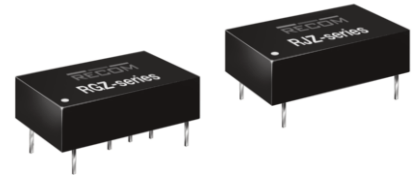

EN-60950-1 Certified
IEC/EN-60601-1 Certified*
* +15/-9 Version excluded

RJZ_RGZ

Derating-Graph (Ambient Temperature)

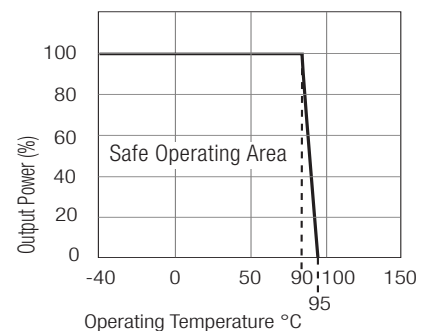

**Any data referred to in this datasheet are of indicative nature and based on our practical experience only. For further details, please refer to our Application Notes.

Refer to Application Notes

www.recom-power.com

Specifications (measured at $T_A = 25^\circ\text{C}$, nominal input voltage, full load and after warm-up)

Storage Temperature Range				-55°C to +125°C
Relative Humidity				95% RH
Package Weight				2.8g
Packing Quantity				24 pcs per Tube
MTBF (+25°C) (+85°C)	} Detailed Information see Application Notes chapter "MTBF"	using MIL-HDBK 217F	RJZ types	893 x 10 ³ hours
			RGZtypes	810 x 10 ³ hours
		using MIL-HDBK 217F	RJZ types	208 x 10 ³ hours
			RGZ types	151 x 10 ³ hours

Certifications

EN General Safety
EN Medical Safety

Report: SPCLVD1109103
Report: SPCMDD120598-4

EN60950-1:2006 + A12:2011
IEC/EN 60601-1:2006, 3rd Edition

Notes

Note 1 Maximum capacitive load is defined as the capacitive load that will allow start up in under 1 second without damage to the converter.

IGBT Application Circuit

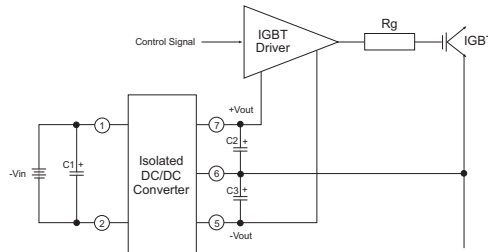

Typical Characteristics

RJZ-xx05S

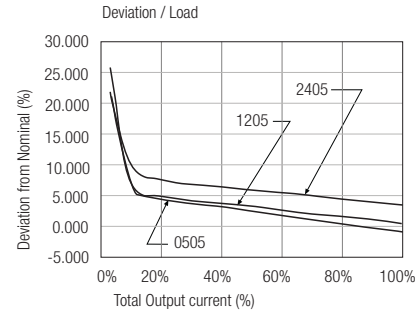
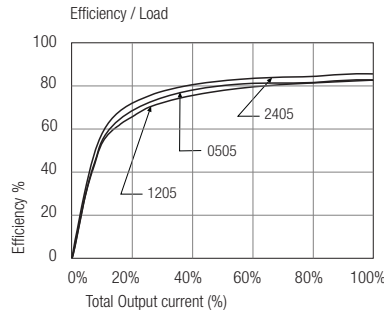

RJZ-xx09S

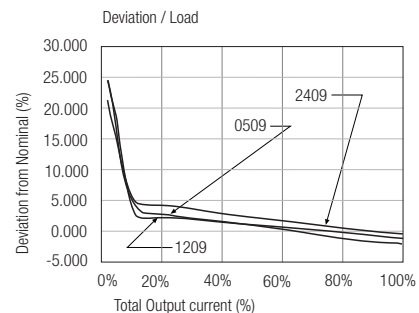
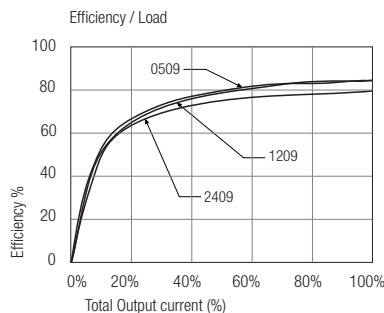

RJZ-xx12S

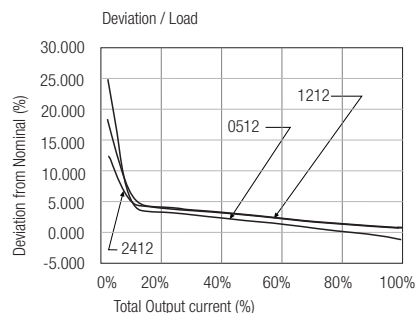
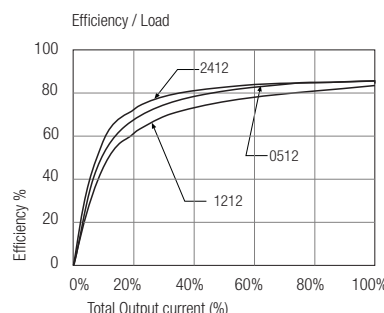

Typical Characteristics

RJZ-xx15S

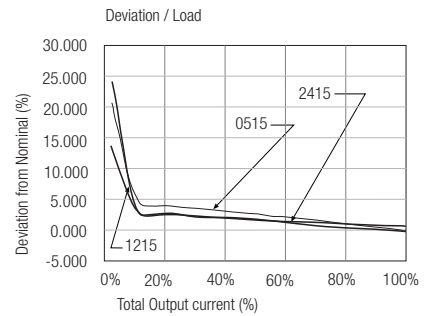
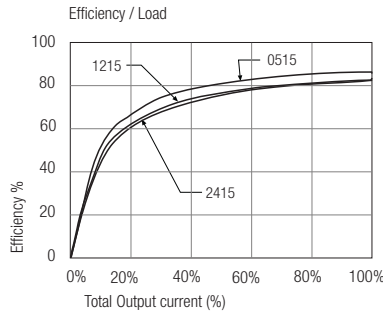

RGZ-xx05D

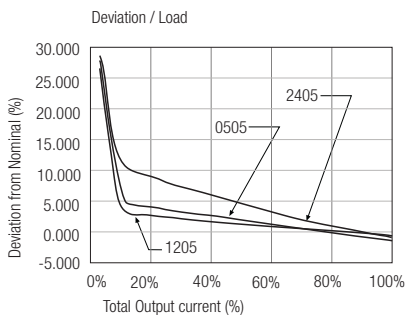
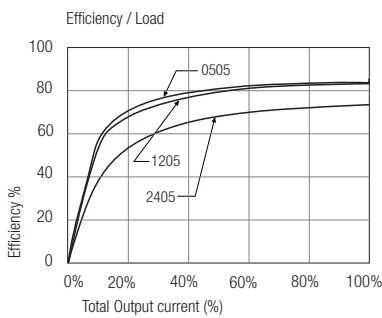

RGZ-xx12D

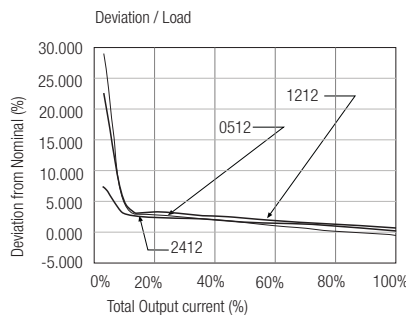
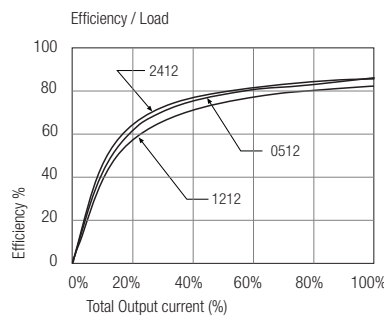

RGZ-xx15D

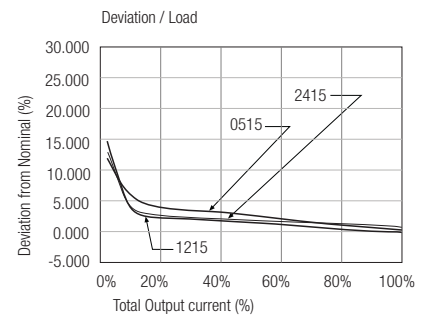
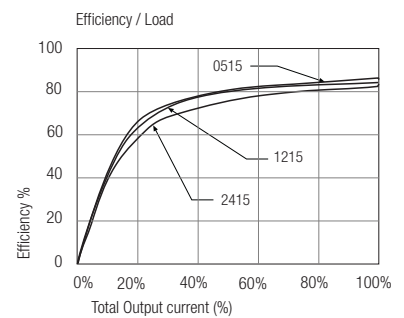

RJZ_RGZ

Package Style and Pinning (mm)

14 PIN DIP Package

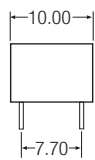
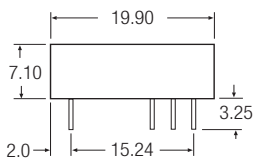

Single Output



Dual Output



+15/-9 Output



Recommended Footprint Details

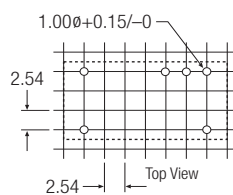
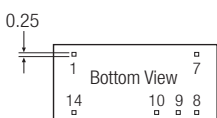

Pin Connections

Pin #	RJZ	RGZ
1	-Vin	-Vin
7	NC	NC
8	+Vout	+Vout
9	No Pin	Com
10	-Vout	-Vout
14	+Vin	+Vin

XX.X ± 0.5 mm
XX.XX ± 0.25 mm
NC = No Connection

The product information and specifications are subject to change without prior notice. All products are designed for non-safety critical commercial and industrial applications. The Buyer agrees to implement safeguards that anticipate the consequences of any failures that might cause harm, loss of life and/or damage property.

Features

Unregulated Converters

- UL/CSA and EN-60950-1 Safety certified
- EN-60601 for Medical Applications
- 6kVDC Isolation
- Optional Continuous Short Circuit Protection
- Efficiency up to 82%
- Space Saving „Skinny DIP“ Package
- Very Low Isolation Capacitance
- Suitable for IGBT Applications

Description

Very high isolation in a small size are the main features of this miniature DIP24 converter, ideal for highly sophisticated industrial, test and measurement and medical designs where board space is at a premium.

Selection Guide

Part Number	Input Voltage (VDC)	Output Voltage (VDC)	Output Current (mA)	Efficiency Std (%)	Max Capacitive Load ⁽¹⁾
RV-xx3.3S*	3.3, 5, 12, 15, 24	3.3	600	70	3300µF
RV-xx05S*	3.3, 5, 12, 15, 24	5	400	70-75	1200µF
RV-xx09S*	3.3, 5, 12, 15, 24	9	222	70-75	1200µF
RV-xx12S*	3.3, 5, 12, 15, 24	12	167	70-75	680µF
RV-xx15S*	3.3, 5, 12, 15, 24	15	132	75-80	680µF
RV-xx24S*	3.3, 5, 12, 15, 24	24	83	75-80	220µF
RV-xx3.3D*	3.3, 5, 12, 15, 24	±3.3	±300	70	±1500µF
RV-xx05D*	3.3, 5, 12, 15, 24	±5	±200	70-75	±470µF
RV-xx09D*	3.3, 5, 12, 15, 24	±9	±111	70-75	±470µF
RV-xx12D*	3.3, 5, 12, 15, 24	±12	±85	70-75	±220µF
RV-xx15D*	3.3, 5, 12, 15, 24	±15	±66	75-80	±220µF
RV-xx24D*	3.3, 5, 12, 15, 24	±24	±42	75-80	±100µF
RV-xx1509D	5, 12, 24	+15/-9	+67/-111	70-82	±330µF

xx = Input Voltage. Other input and output voltage combinations available on request.

* add Suffix "P" for Continuous Short Circuit Protection, e.g. RV-0505S/P, RV-0505D/P

Specifications (measured at $T_A = 25^\circ\text{C}$, nominal input voltage, full load and after warm-up)

Input Voltage Range	±10%
Output Voltage Accuracy	±5%
Line Voltage Regulation	1.2%/1% of Vin typ.
Load Voltage Regulation (10% to 100% full load)	3.3V output types 20% max. 5V output type 15% max. 9V, 12V, 15V, 24V output types, RV-xx1509D 10% max.
Output Ripple and Noise (20MHz limited)	200mVp-p max.
Operating Frequency	20kHz min. / 50kHz typ. / 85kHz max. RV-xx1509D 20kHz min. / 47kHz typ.
Efficiency at Full Load	70% min. / 75% typ.
Minimum Load = 0%	Specifications valid for 10% minimum load only.
Isolation Voltage	(tested for 1 second) 6000VDC (rated for 1 minute**) 3000VAC / 60Hz
Isolation Capacitance	2pF min. / 12pF max.
Isolation Resistance	15 GΩ min.
Short Circuit Protection	1 Second
P-Suffix	Continuous
Operating Temperature Range (free air convection, without derating)	-40°C to +90°C (see Graph)
Storage Temperature Range	-55°C to +125°C

continued on next page

ECONOLINE

DC/DC-Converter

with 3 year Warranty

RECOM

2 Watt DIP24 Miniature Single & Dual Output

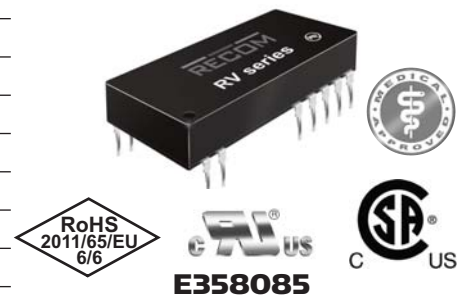

EN-60950-1 Certified
IEC/EN-60601-1 Certified*
UL/CSA 60950-1 Certified*
*** +15/-9 Version excluded**

RV

Derating-Graph (Ambient Temperature)

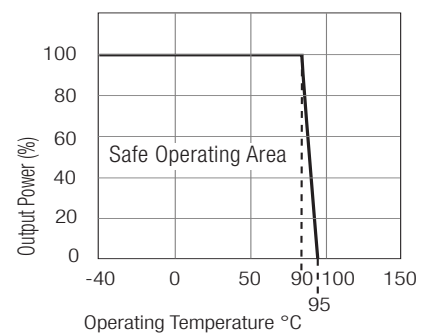

**Any data referred to in this datasheet are of indicative nature and based on our practical experience only. For further details, please refer to our Application Notes.

Refer to Application Notes

Specifications (measured at $T_A = 25^\circ\text{C}$, nominal input voltage, full load and after warm-up)

Relative Humidity				95% RH
Package Weight				9g
Packing Quantity				15 pcs per Tube
MTBF (+25°C)	} Detailed Information see	using MIL-HDBK 217F	1154 x 10 ³ hours	
		(+85°C)	} Application Notes chapter "MTBF" using MIL-HDBK 217F	168 x 10 ³ hours
Certifications	UL/cUL General Safety	Report: E358085	UL 60950-1 2nd Ed.	
	EN General Safety	Report: SPCLVD1109103	EN60950-1:2006 + A12: 2011	
	EN Medical Safety	Report: SPCMDD1205098-4	IEC/EN60601-1:2006, 3rd Edition	

Notes

Note 1 Maximum capacitive load is defined as the capacitive load that will allow start up in under 1 second without damage to the converter.

Tolerance Envelope

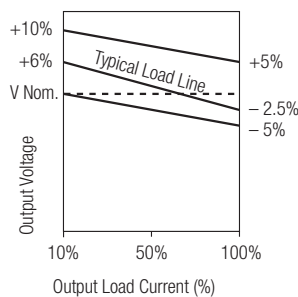

Typical Characteristics

RV-xx05S

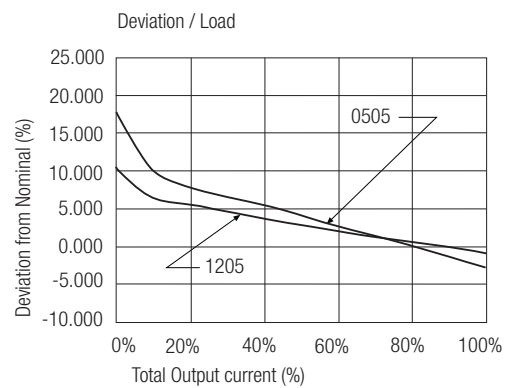
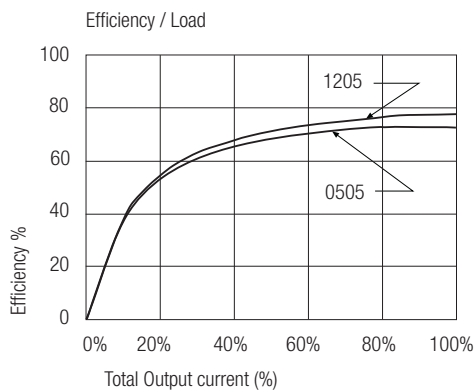

RV-xx12S

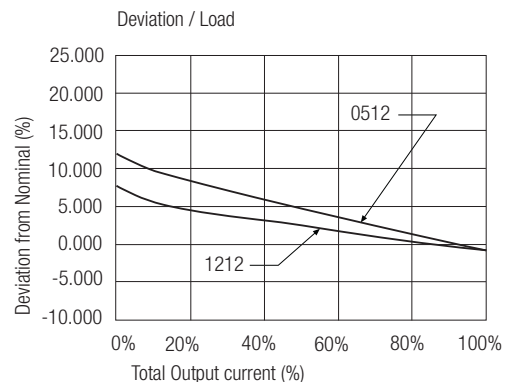
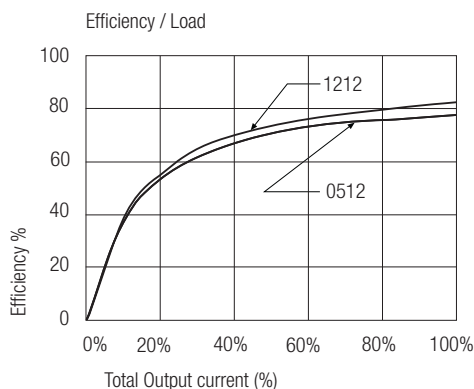

Typical Characteristics

RV-xx05D

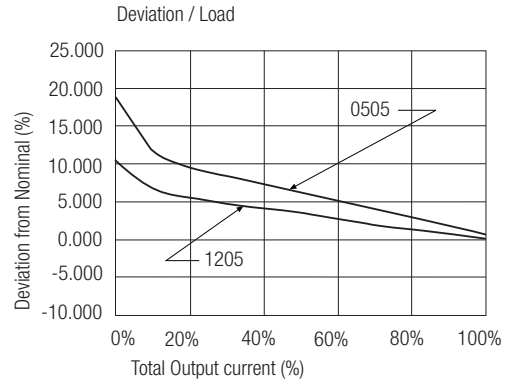
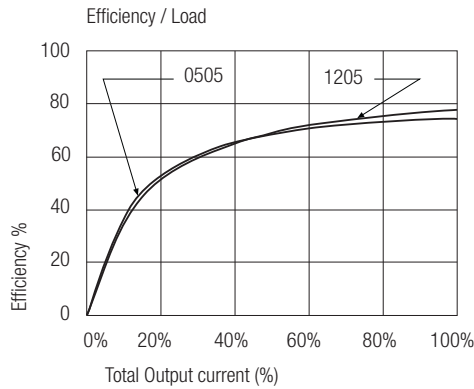

RV-xx12D

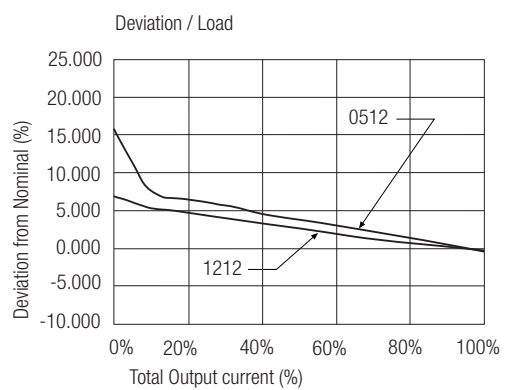
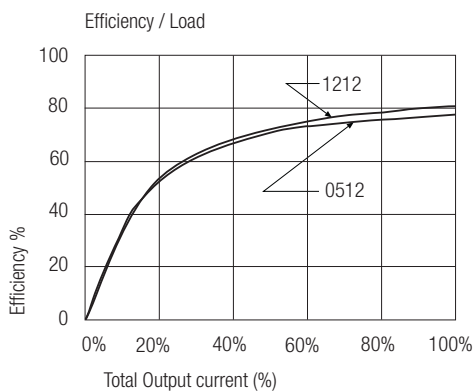

Applications

IGBT Application Circuit

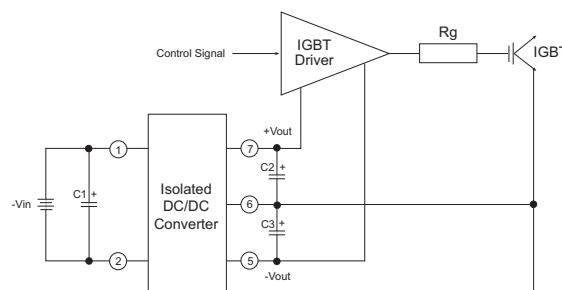

Package Style and Pinning (mm)

24 PIN DIP Miniature Package Style

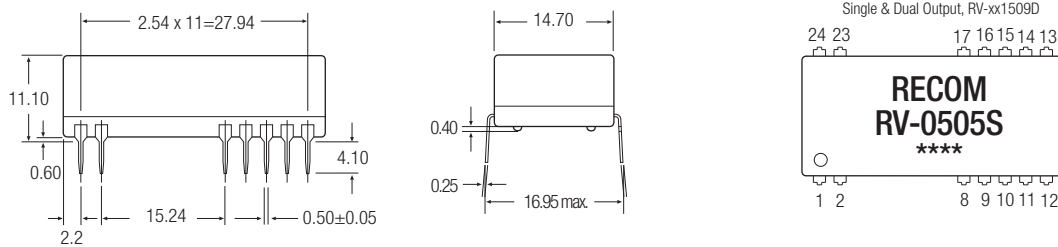

Recommended Footprint Details

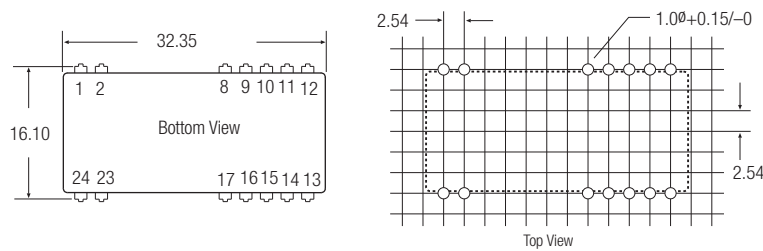

Pin Connections

Pin #	Single
1	+Vin
2	-Vin
8, 9, 11, 14	NC
10, 15	-Vout
12 & 13	+Vout
16, 17, 23, 24	NC

Pin Connections

Pin #	Dual
1	+Vin
2	-Vin
8, 17	-Vout
9, 11, 14, 16, 23, 24	NC
10 & 15	Com
12, 13	+Vout

NC = No Connection
XX.X ± 0.5 mm
XX.XX ± 0.25 mm

Features

Unregulated Converters

- UL/CSA and EN-60950-1 Safety certified
- EN-61010 for Test, Measurement and Lab Use
- UL/CSA and EN-60601 for Medical Applications
- 6.4kVDC or 8kV Reinforced Isolation
- Optional Continuous Short Circuit Protection
- Efficiency to 88%
- Space Saving „Skinny DIP“ Package
- Very Low Isolation Capacitance

Description

Very high isolation in a small size are the main features of this miniature DIP24 converter, ideal for highly sophisticated industrial, test and measurement and medical designs where board space is at a premium.

Selection Guide

Part Number SIP 7	Reinforced Isolation (kVDC)	Input Voltage (VDC)	Output Voltage (VDC)	Output Current (mA)	Efficiency Std (%)	Max Capacitive Load ⁽¹⁾
RV-xx3.3S	/R6.4 & /R8	3.3, 5, 12, 15, 24	3.3	600	70-78	3300µF
RV-xx05S	/R6.4 & /R8	3.3, 5, 12, 15, 24	5	400	76-80	1200µF
RV-xx09S	/R6.4 & /R8	3.3, 5, 12, 15, 24	9	222	78-85	1200µF
RV-xx12S	/R6.4 & /R8	3.3, 5, 12, 15, 24	12	167	78-85	680µF
RV-xx15S	/R6.4 & /R8	3.3, 5, 12, 15, 24	15	132	78-88	680µF
RV-xx3.3D	/R6.4 & /R8	3.3, 5, 12, 15, 24	±3.3	±300	70-78	±1500µF
RV-xx05D	/R6.4 & /R8	3.3, 5, 12, 15, 24	±5	±200	75-82	±470µF
RV-xx09D	/R6.4 & /R8	3.3, 5, 12, 15, 24	±9	±111	76-84	±470µF
RV-xx12D	/R6.4 & /R8	3.3, 5, 12, 15, 24	±12	±85	78-86	±220µF
RV-xx15D	/R6.4 & /R8	3.3, 5, 12, 15, 24	±15	±66	78-86	±220µF

xx = Input Voltage. Other input and output voltage combinations available on request.

* add Suffix "P" for Continuous Short Circuit Protection, e.g. RV-0505S/P, RV-0505D/P

* add Suffix "/R6.4" or "/R8" for Reinforced Isolation, e.g. RV-0505S/R6.4, RV-0505D/P/R8

For functional isolation, please refer to RV series datasheet

Specifications (measured at $T_A = 25^\circ\text{C}$, nominal input voltage, full load and after warm-up)

Input Voltage Range			±10%
Output Voltage Accuracy			±5%
Line Voltage Regulation			1.2%/1% of Vin typ.
Load Voltage Regulation (10% to 100% full load)	3.3V output types		20% max.
	5V output type		15% max.
	9V, 12V, 15V, 24V output types		10% max.
Output Ripple and Noise (20MHz limited)			200mVp-p max.
Operating Frequency			20kHz min. / 50kHz typ. / 85kHz max.
Efficiency at Full Load			70% min. / 75% typ.
Minimum Load = 0%	Specifications valid for 10% minimum load only.		
Isolation Voltage	/R6.4	(tested for 1 second)	6400VDC
		(rated for 1 minute**)	3200VAC / 60Hz
	/R8	(tested for 1 second)	8000VDC
		(rated for 1 minute**)	4000VAC / 60Hz
Isolation Capacitance			2pF min. / 12pF max.
Isolation Resistance			15 GΩ min.
Short Circuit Protection			1 Second
P-Suffix			Continuous
Operating Temperature Range (free air convection)			-40°C to +85°C (see Graph)
Storage Temperature Range			-55°C to +125°C

continued on next page

ECONOLINE

DC/DC-Converter

with 3 year Warranty

RECOM

2 Watt DIP24 Miniature Single & Dual Output

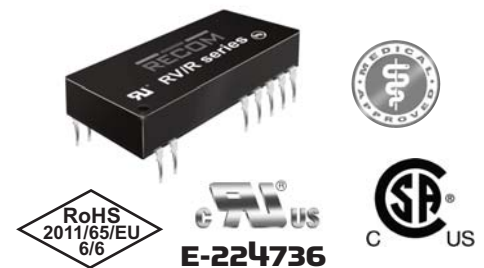

EN-60950-1 Certified
EN-60601-1 Certified
UL/CSA 60950-1 Certified
UL-60601-1 Certified
EN-61010-1 Certified
IEC-60601-1 CB Report

RV/R

Derating-Graph (Ambient Temperature)

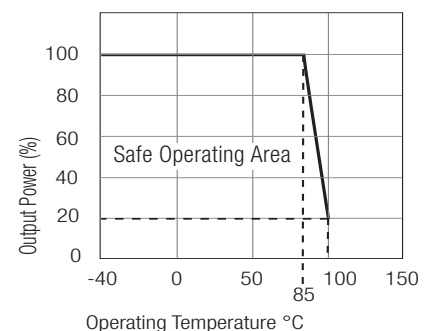

**Any data referred to in this datasheet are of indicative nature and based on our practical experience only. For further details, please refer to our Application Notes.

Refer to Application Notes

Specifications (measured at $T_A = 25^\circ\text{C}$, nominal input voltage, full load and after warm-up)

Relative Humidity			95% RH
Package Weight			9g
Packing Quantity			15 pcs per Tube
MTBF (+25°C) (+85°C)	} Detailed Information see Application Notes chapter "MTBF"	using MIL-HDBK 217F	1154 x 10 ³ hours
		using MIL-HDBK 217F	168 x 10 ³ hours
Reinforced Isolation	Transformer Creepage	/R6.4 Types	5.5 mm min.
	Transformer Clearance	/R6.4 Types	5.5 mm min.
	PCB Creepage & Clearance	/R6.4 Types	4.8 mm min.
Certifications			
Measurement, Control and Laboratory Use Safety	Report: T1301251-313	EN 61010-1 : 2010	
CSA General Safety		UL 60950-1 1st Edition C22.2 No. 60950-1-03	
UL/cUL Medical Safety	Report: E314885-A4	UL60601-1 3rd Edition	
CSA Medical Safety	Report: 2207629	CAN/CSA-22.2 No 601.1-M90	
EN General Safety	Report: SPCLVD1310079-1	EN60950-1 : 2006	
EN Medical Safety	Report: CA-10168-A1-UL	IEC/EN 60601-1 3rd Edition	

Notes

Note 1 Maximum capacitive load is defined as the capacitive load that will allow start up in under 1 second without damage to the converter.

Tolerance Envelope

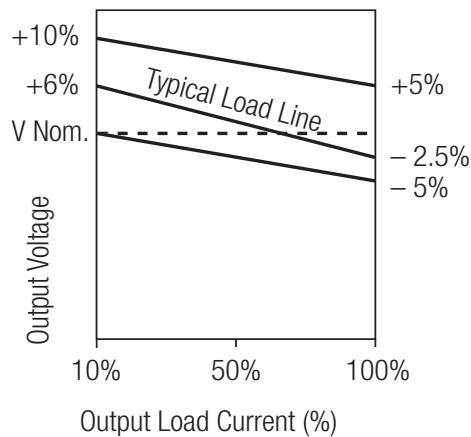

RV-xx05S/R6.4
RV-xx05S/R8

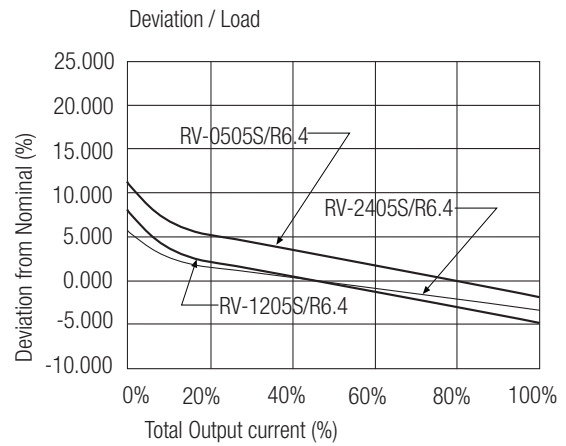
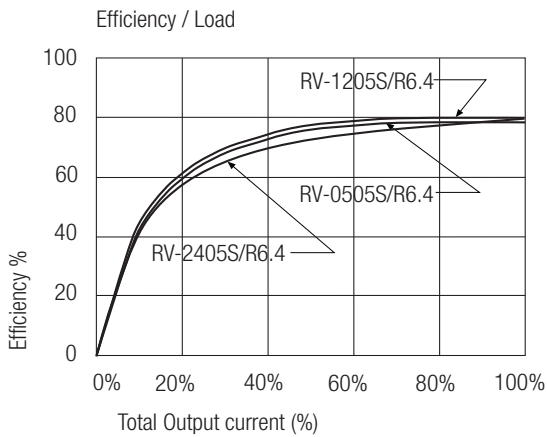

RV-xx05D/R6.4
RV-xx05D/R8

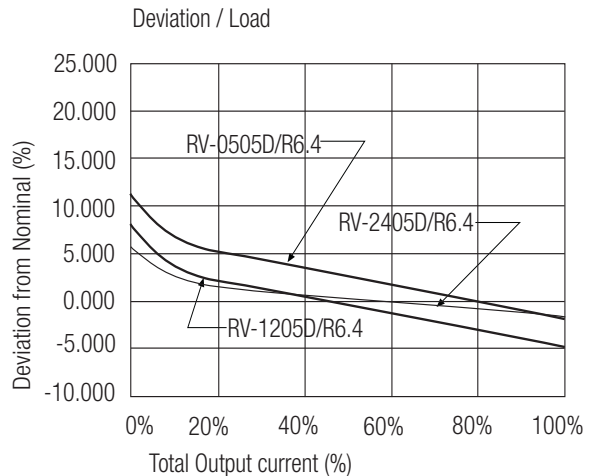
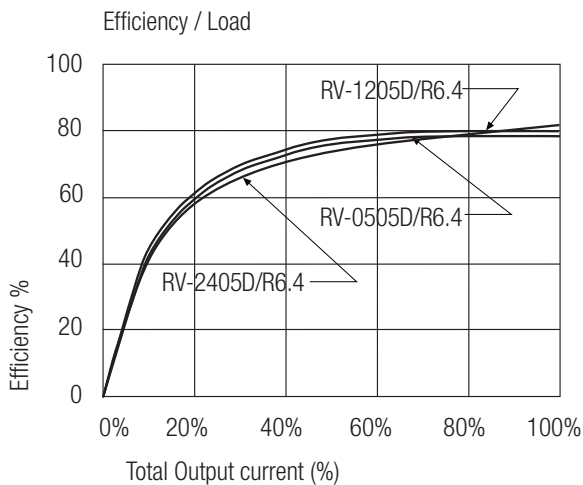

Package Style and Pinning (mm)

24 PIN DIP Miniature Package Style

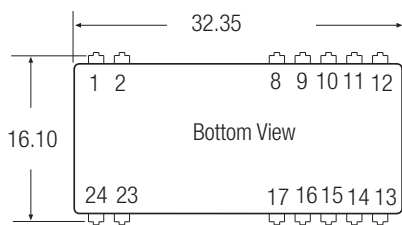
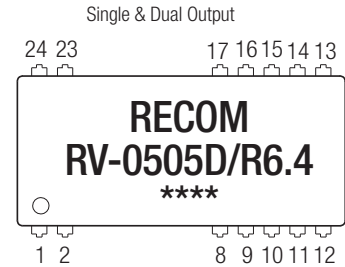
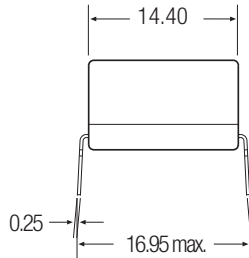
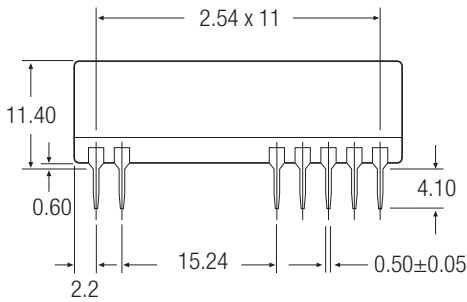

Recommended Footprint Details

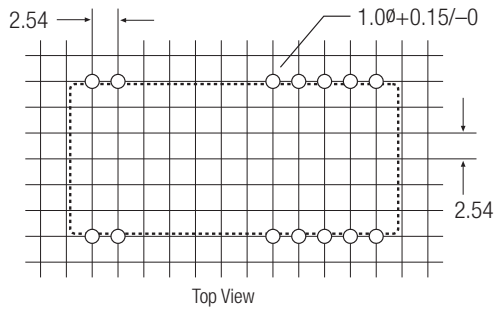

Pin Connections

Pin #	Single
1	+Vin
2	-Vin
8, 9, 11, 14	NC
10, 15	-Vout
12 & 13	+Vout
16, 17, 23, 24	NC

Pin Connections

Pin #	Dual
1	+Vin
2	-Vin
8, 17	-Vout
9, 11, 14, 16, 23, 24	NC
10 & 15	Com
12, 13	+Vout

XX.X ± 0.5 mm
XX.XX ± 0.25 mm

Features

Regulated Converter

- 1kVDC or 2kVDC Isolation
- SMD Package Styles
- Single Regulated Output (Internal Linear Regulator)
- UL94V-0 Package Material
- Optional Continuous Short Circuit Protected
- Fully Encapsulated
- Efficiency to 62 %
- Built-In EN55022 Class A Filter

Description

The R0.5Z series DC/DC converter has been designed for isolating or converting DC power rails where board space is at a premium. Although no larger than a standard unregulated SMD converter, the R0.5Z series also incorporates an internal linear regulator to deliver a stable output voltage which makes it ideal for powering logic level or supply voltage sensitive circuitry.

Specifications (measured at $T_A = 25^\circ\text{C}$, nominal input voltage, full load and after warm-up)

Part Number SMD	Input Voltage (VDC)	Output Voltage (VDC)	Output Current (mA)	Efficiency (%)	Max Capacitive Load ⁽¹⁾
R0.5Z-xx05*	5, 12, 15, 24	5	100	50	1000 μF
R0.5Z-xx12*	5, 12, 15, 24	12	42	60	220 μF
R0.5Z-xx15*	5, 12, 15, 24	15	33	62	220 μF

xx = Input Voltage

* add Suffix "P" for Continuous Short Circuit Protection, e.g. R0.5Z-0505/P

* add Suffix „H" for 2kVDC Isolation Voltage, e.g. R0.5Z-0505/H

* add suffix -R for tape & reel packing e.g. R0.5Z-0505-R, R0.5Z.0505/P-R

For more details and dimensions of the tapes and reels see Application Notes

Specifications (Core Operating Area)

Input Voltage Range		$\pm 5\%$
Output Voltage Accuracy		$\pm 5\%$
Line Voltage Regulation		1% max.
Load Voltage Regulation (10% to 100% full load)		1% max.
Output Ripple and Noise (20MHz limited)		100mVp-p max.
Operating Frequency		20kHz min. / 50kHz typ. / 90kHz max.
Efficiency at Full Load		50% min. / 60% typ.
Minimum Load		10% ⁽²⁾
No Load Power Consumption		127mW min. / 155mW typ. / 320mW max.
Isolation Voltage		(tested for 1 second) 1000VDC (rated for 1 minute**) 500VAC / 60Hz
Isolation Voltage	H-Suffix	(tested for 1 second) 2000VDC
	H-Suffix	(rated for 1 minute**) 1000VAC / 60Hz
Isolation Capacitance		25pF min. / 75pF max.
Isolation Resistance		10 G Ω min.
Short Circuit Protection		1 Second
P-Suffix		Continuous
Operating Temperature Range (natural convection)		-40°C to +85°C (see Graph)
Storage Temperature Range		-55°C to +125°C
Reflow Temperature	ROHS compliant	245°C (30 sec) max.
Vapour Phase Process		230°C (90 sec) max.
		(for more details see Application Notes)
Relative Humidity		95% RH
Package Weight		1.2g
Packing Quantity		33 pcs per tube 500 pcs per Reel'
MTBF (+25°C)	} Detailed Information see Application Notes chapter "MTBF"	using MIL-HDBK 217F 3947 x 10 ³ hours
(+85°C)		using MIL-HDBK 217F 841 x 10 ³ hours

continued on next page

ECONOLINE

DC/DC-Converter

with 3 year Warranty

RECOM

0.5 Watt SMD Isolated Single Output



E358085

EN-60950-1 Certified
EN-60601-1 Certified*
UL-60950-1 Certified
(* / H suffix)

R0.5Z

Derating-Graph (Ambient Temperature)

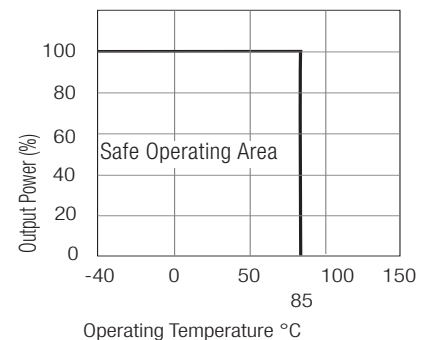

**Any data referred to in this datasheet are of indicative nature and based on our practical experience only. For further details, please refer to our Application Notes.

Refer to Application Notes

Specifications (Core Operating Area)

Conducted / Radiated Emissions	EN55022	Level A
Certifications		
EN General Safety	Report-No.: SPCLVD1211033-3	EN60950-1:2006 + A12:2011
EN Medical Safety	Report: MDD1205098-2 + RM1205098-2 Medical Report + ISO14971 Risk Assessment	IEC/EN 60601-1 3rd Edition
UL General Safety	Report-No.: E358085	UL60950-1, 2nd Edition

Notes

- Note 1: Maximum capacitive load is defined as the capacitive load that will allow start up in under 1 second without damage to the converter
- Note 2: The R0.5Z series require a minimum of 10% loading on the output to maintain specified regulation. Operating under no-load condition will not damage these devices, however they may not meet all listed specifications.

Typical Characteristics

R0.5Z-xx05

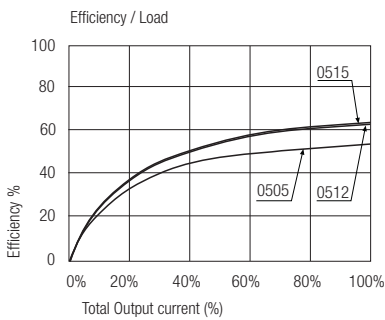

R0.5Z-xx12

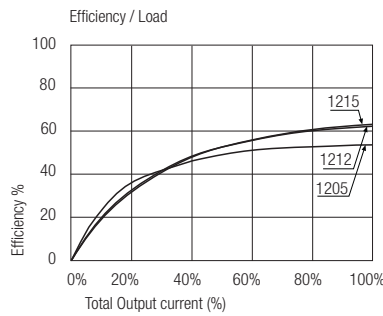

R0.5Z-xx15

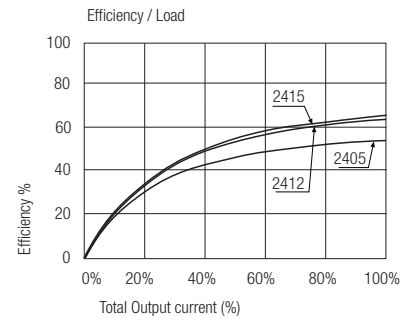

Package Style and Pinning (mm)

10 PIN Single SMD Package

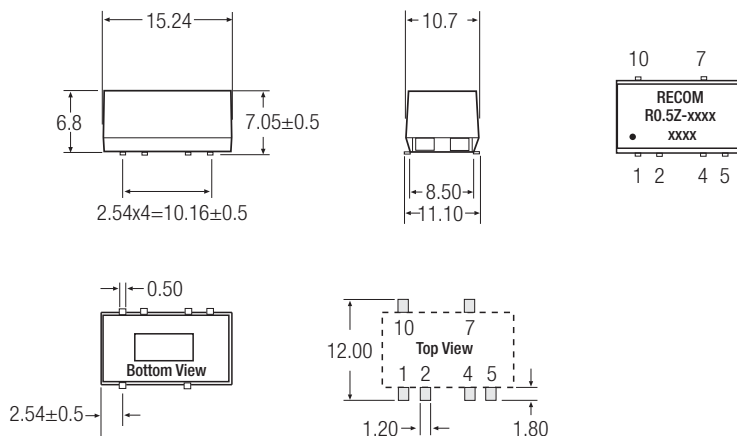

Recommended Footprint Details

Pin Connections

Pin #	Function
1	-Vin
2	+Vin
4	-Vout
5	-Vout
7	+Vout
10	NC

NC= No Connection

XX.X ± 0.5 mm
XX.XX ± 0.25 mm

Features

Regulated Converters

- 1kVDC & 2kVDC Isolation
- UL94V-0 Package Material
- RoHS 6/6
- Toroidal Magnetics
- Optional Continuous Short Circuit Protected
- Built-In EN55022 Class A Filter

Description The R1Z series DC/DC converter has been designed for isolating or converting DC power rails where an SMD format with regulated output is required, although it is no larger than a standard unregulated SMD converter.

Selection Guide

Part Number SMD	2kVDC	Input Voltage (VDC)	Output Voltage (VDC)	Output Current (mA)	Max Capacitive Load ⁽¹⁾
R1Z-xx3.3*	(/H)	3.3, 5, 12, 15, 24	3.3	303	2200µF
R1Z-xx05*	(/H)	3.3, 5, 12, 15, 24	5	200	1200µF
R1Z-xx09*	(/H)	3.3, 5, 12, 15, 24	9	111	680µF
R1Z-xx12*	(/H)	3.3, 5, 12, 15, 24	12	84	680µF
R1Z-xx15*	(/H)	3.3, 5, 12, 15, 24	15	66	470µF

xx= Input Voltage (other input and output voltage combinations available on request)

*add suffix -R for tape & reel packing e.g. R1Z-0505-R

*add suffix /P for continuous short circuit protection, e.g. R1Z-0505/P-R

Specifications (measured at $T_A = 25^\circ\text{C}$, nominal input voltage, full load and after warm-up)

Input Voltage Range		$\pm 5\%$
Output Voltage Accuracy		$\pm 2\%$
Line Voltage Regulation		1% max.
Load Voltage Regulation		1% max.
Output Ripple and Noise (at 20MHz BW)		100mVp-p max.
Operating Frequency		20kHz min. / 40kHz typ. / 80kHz max.
Efficiency at Full Load		50% min. / 60% typ.
Minimum Load		10% ⁽²⁾
No Load Power Consumption		134mW min. / 217mW typ. / 350mW max.
Isolation Voltage		(tested for 1 second) 1000VDC (rated for 1 minute**) 500VAC / 60Hz
Isolation Voltage	H-Suffix	(tested for 1 second) 2000VDC (rated for 1 minute**) 1000VAC / 60Hz
Isolation Capacitance		70pF typ.
Isolation Resistance		10 GW min.
Short Circuit Protection		1 Second
P-Suffix		Continuous
Operating Temperature Range (natural convection)		-40°C to +70°C (see Graph)
Storage Temperature Range		-55°C to +125°C
Reflow Temperature	ROHS compliant	245°C (30 sec) max.
Vapour Phase Process		230°C (90 sec) max.
		(for more details see Application Notes)
Relative Humidity		95% RH
Package Weight		1.6g
Packing Quantity		33 pcs per tube 250 pcs per Reel
MTBF	R1Z (+25°C)	using MIL-HDBK 217F 2203 x 10 ³ hours
	(+70°C)	using MIL-HDBK 217F 391 x 10 ³ hours
	R1Z/P (+25°C)	using MIL-HDBK 217F 2387 x 10 ³ hours
	(+70°C)	using MIL-HDBK 217F 641 x 10 ³ hours

For detailed information see Application Notes chapter "MTBF"

Conducted / Radiated Emissions	EN55022	Level A
EN General Safety	Report: SPCLVD1211033-3	EN60950-1:2006 + A12:2011
EN Medical Safety	Report: MDD1205098-4 + RM1205098-4	IEC/EN 60601-1 3rd Edition Medical Report + ISO14971 Risk Assessment
UL General Safety	Report: E358085	UL60950-1, 2nd Edition

ECONOLINE

DC/DC-Converter

with 3 year Warranty

RECOM

1 Watt SMD Miniature Isolated Single Output



E358085



EN-60950-1 Certified
EN-60601-1 Certified*
UL-60950-1 Certified
(* /H suffix)

R1Z

Derating-Graph (Ambient Temperature)

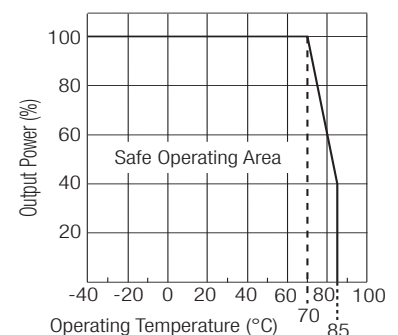

**Any data referred to in this datasheet are of indicative nature and based on our practical experience only. For further details, please refer to our Application Notes.

Refer to Application Notes

Typical Characteristics

R1Z-3.3xx/P

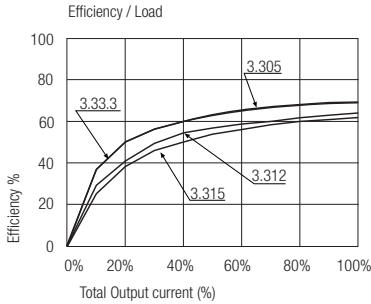

R1Z-05xx/P

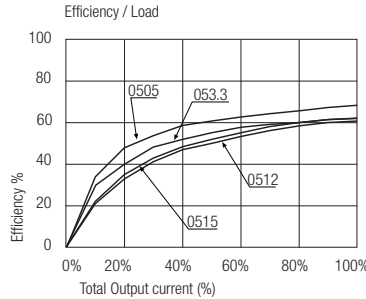

R1Z-12xx/P

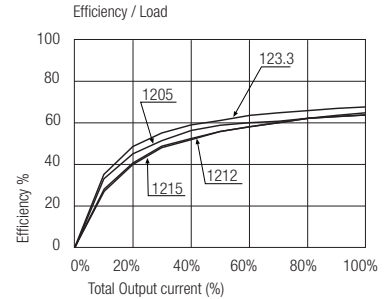

R1Z-15xx/P

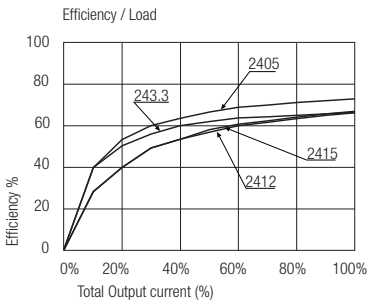

R1Z-3.3xx

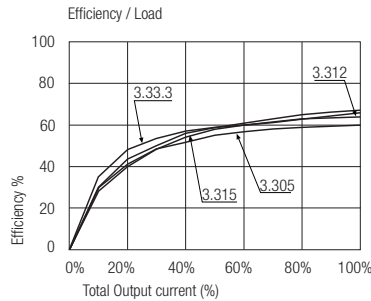

R1Z-05xx

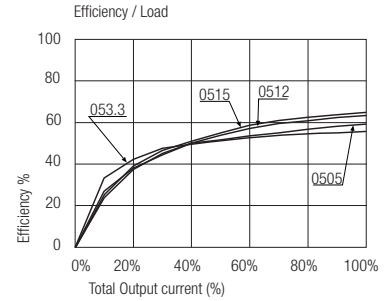

R1Z-12xx

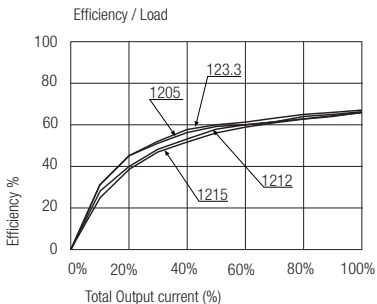

Notes

Note 1: Maximum capacitive load is defined as the capacitive load that will allow start up in under 1second without damage to the converter

Note 2: The R1Z series require a minimum of 10% loading on the output to the maintain specified regulation. Operating under no-load condition will not damage these devices, however they may not meet all listed specifications.

R1Z-15xx

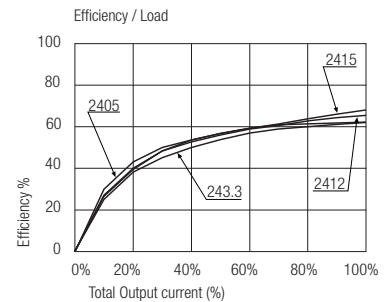

Package Style and Pinning (mm)

10 PIN Single SMD Package

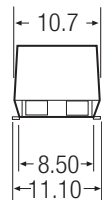
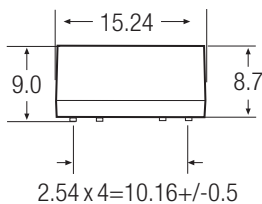

Recommended Footprint Details

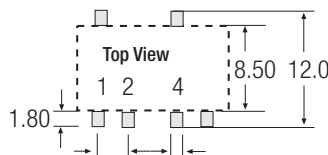
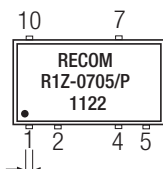

Ordering Example: R1Z-0505 (5V Input, 5V Output, not short circuit protected)
R1Z-0505/HP (5V Input, 5V Output, 2kVDC Isolation and short circuit protection)

Pin Connections

Pin #	Function
1	-Vin
2	+Vin
4	-Vout
5	-Vout
7	+Vout
10	NC

NC= No Connection

XX.X ± 0.5 mm
XX.XX ± 0.25 mm

Features

Regulated Converters

- On/Off Pin
- 1kVDC Isolation
- UL94V-0 Package Material
- Optional Continuous Short Circuit Protected
- Internal linear regulator
- Efficiency to 70 %
- Adjustable Output Voltage

Description

The RY series DC/DC converter is a low cost general purpose isolated converter with a built-in linear regulator to give a regulated, load-independent output. It is available with single or dual outputs. A useful feature is the CTRL pin on the single output version which allows the converter to be adjusted or controlled by an external enable signal.

Selection Guide

Part Number	Input Voltage (VDC)	Output Voltage (VDC)	Output Current (mA)	Efficiency (%)	Max Capacitive Load ⁽¹⁾
RY-xx05S	5, 9, 12, 15, 24	5	200	58-60	1200µF
RY-xx09S	5, 9, 12, 15, 24	9	111	56-62	1200µF
RY-xx12S	5, 9, 12, 15, 24	12	84	60-66	680µF
RY-xx15S	5, 9, 12, 15, 24	15	66	60-66	680µF
RY-xx24S	5, 9, 12, 15, 24	24	42	60-68	220µF
RY-xx05D	5, 9, 12, 15, 24	±5	±100	50-58	±470µF
RY-xx09D	5, 9, 12, 15, 24	±9	±55	52-60	±470µF
RY-xx12D	5, 9, 12, 15, 24	±12	±42	58-68	±330µF
RY-xx15D	5, 9, 12, 15, 24	±15	±33	62-68	±330µF
RY-xx24D	5, 9, 12, 15, 24	±24	±21	64-70	±100µF

xx = Input Voltage. Other input and output voltage combinations available on request.

* add Suffix "P" for Continuous Short Circuit Protection, e.g. RY-0505S/P, RY-0505D/P

Specifications (measured at $T_A = 25^\circ\text{C}$, nominal input voltage, full load and after warm-up)

Input Voltage Range			±5%
Output Voltage Accuracy			±5%
Line Voltage Regulation			±1% max.
Load Voltage Regulation (10% to 100% full load)			±1% max.
Minimum Load			10% ⁽²⁾
Output Ripple and Noise (20MHz limited)			100mVp-p max.
Operating Frequency			30kHz min. / 50kHz typ. / 88kHz max.
Efficiency at Full Load			54% min. / 60% typ.
Isolation Voltage	(tested for 1 second)		1000VDC
	(rated for 1 minute**)		1500VAC / 60Hz
Isolation Capacitance	Single output types		30pF min. / 150pF max.
	Dual output types		40pF min. / 72pF max.
Isolation Resistance			10 GΩ min.
Short Circuit Protection			1 Second
P-Suffix			Continuous
Operating Temperature Range (free air convection)			-40°C to +70°C (see Graph)
Storage Temperature Range			-55°C to +125°C
Relative Humidity			95% RH
Package Weight	RY Single & Dual output types		2.8g
Packing Quantity			25 pcs per Tube
MTBF (+25°C)	} Detailed Information see Application Notes chapter "MTBF"	using MIL-HDBK 217F	924 x 10 ³ hours
(+70°C)		using MIL-HDBK 217F	135 x 10 ³ hours
Certifications			
EN General Safety	Report: SPCLVD1109103		EN60950-1:2006 + A12:2011

continued on next page

ECONOLINE

DC/DC-Converter

with 3 year Warranty

RECOM

1 Watt

SIP7

Single & Dual Output



EN-60950-1 Certified

RY

Derating-Graph (Ambient Temperature)

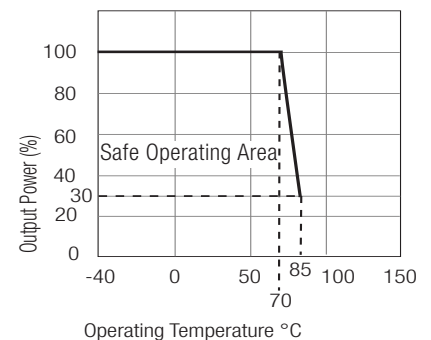

**Any data referred to in this datasheet are of indicative nature and based on our practical experience only. For further details, please refer to our Application Notes.

Refer to Application Notes

Specifications (measured at $T_A = 25^\circ\text{C}$, nominal input voltage, full load and after warm-up)

Notes

Note 1: Maximum capacitive load is defined as the capacitive load that will allow start up in under 1 second without damage to the converter

Note 2: The RY series require a minimum of 10% loading on the output to maintain specified regulation. Operating under un-load condition will not damage these devices, however they may not meet all listed specifications.

Typical Characteristics

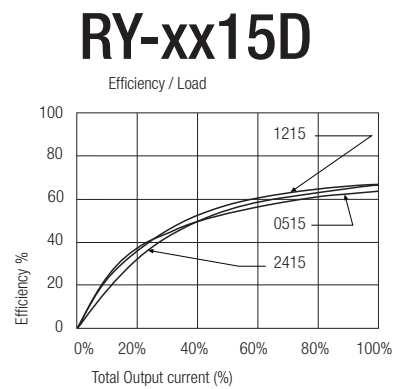
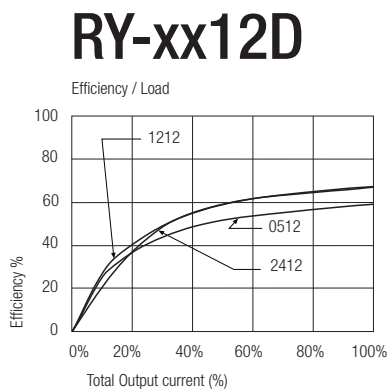
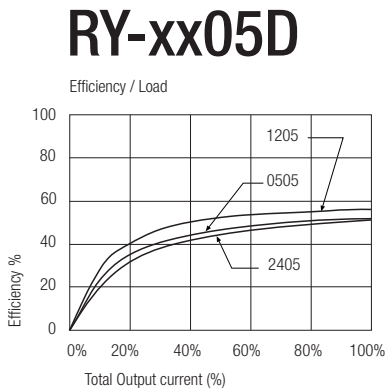
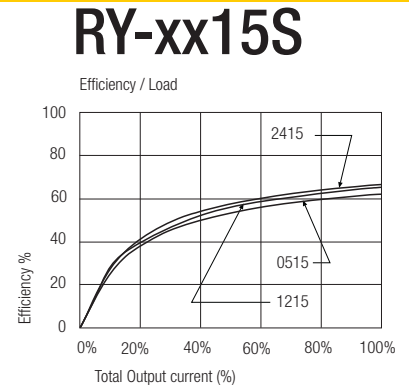
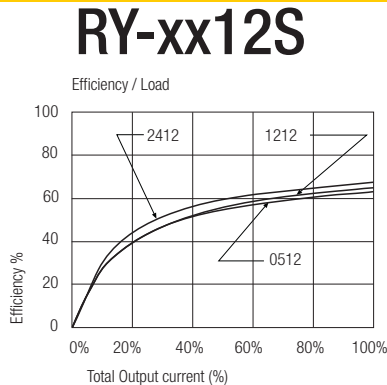
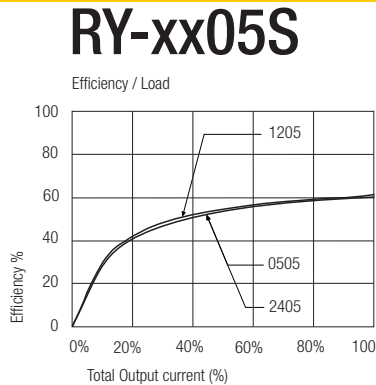

Package Style and Pinning (mm)

SIP7 Package

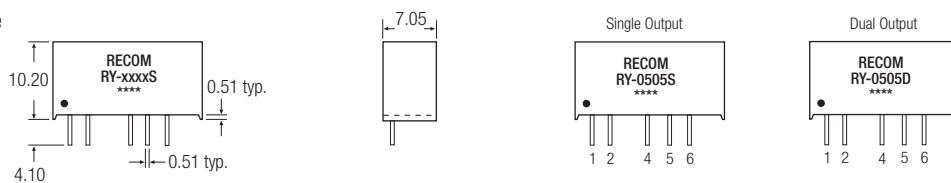

Recommended Footprint Details

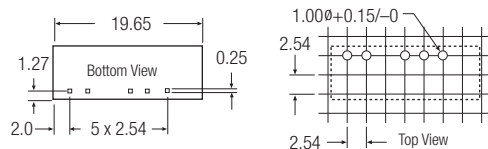

Pin Connections

Pin #	Single	Dual
1	+Vin	+Vin
2	-Vin	-Vin
4	-Vout	-Vout
5	CTRL	Com
6	+Vout	+Vout

XX.X ± 0.5 mm
XX.XX ± 0.25 mm

Typical On/Off Control and Adjustable Output Applications

On/Off Control

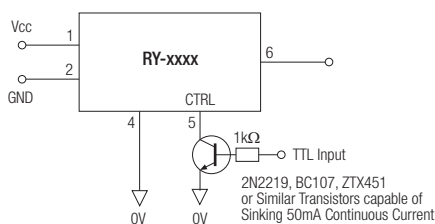

Adjustable Output

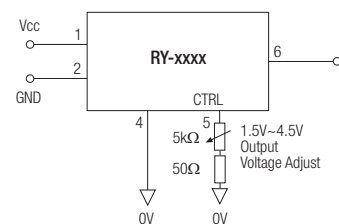

The product information and specifications are subject to change without prior notice. All products are designed for non-safety critical commercial and industrial applications. The Buyer agrees to implement safeguards that anticipate the consequences of any failures that might cause harm, loss of life and/or damage property.

Features

Regulated Converters

- Internal linear regulator
- 1kVDC Isolation
- UL94V-O Package Material
- Continuous Short Circuit Protected
- Current Foldback
- Efficiency to 63%
- +/- 10% Input Voltage Range

Description

The RY-SCP and -DCP series DC/DC converter are low cost general purpose isolated converters with a built-in linear regulator to give a regulated, load-independent output. It is available with single or dual outputs. The converters are both short circuit and overload protected.

Selection Guide

Part Number	Input Voltage (VDC)	Output Voltage (VDC)	Output Current (mA)	Efficiency (%)	Max Capacitive Load ⁽¹⁾
RY-xx05SCP	5,12, 24	5	200	57-62	1200µF
RY-xx12SCP	5, 12, 24	12	84	59-63	680µF
RY-xx15SCP	5, 12, 24	15	66	62-63	680µF
RY-xx05DCP	5, 12, 24	±5	±100	57-62	±470µF
RY-xx12DCP	5, 12, 24	±12	±42	59-63	±330µF
RY-xx15DCP	5,12, 24	±15	±33	62-63	±330µF

xx = Input Voltage. Other input and output voltage combinations available on request.

Specifications (measured at T_A = 25°C, nominal input voltage, full load and after warm-up)

Input Voltage Range		±10%	
Output Voltage Accuracy		±2%	
Line Voltage Regulation		±0.5% max.	
Load Voltage Regulation (10% to 100% full load)		±0.5% max.	
Minimum Load		10% ⁽²⁾	
Output Ripple and Noise (20MHz limited)		50mVp-p max.	
Operating Frequency		100kHz max.	
Efficiency at Full Load		see table above	
Isolation Voltage	(tested for 1 second)	1000VDC	
	(rated for 1 minute)	500VAC / 60Hz	
Isolation Capacitance	Single output types	20pF max.	
Isolation Resistance		10 GΩ min.	
Short Circuit Protection	Single & Dual output types	Current Foldback	
		Continuous	
Operating Temperature Range (free air convection)		-40°C to +70°C (see Graph)	
Storage Temperature Range		-55°C to +125°C	
Temperature Coefficient		0.03%/°C	
Relative Humidity		95% RH	
Package Weight	Single & Dual output types	2.9g	
Packing Quantity		25 pcs per Tube	
MTBF (+25°C)	} Detailed Information see Application Notes chapter "MTBF"	using MIL-HDBK 217F	1023 x 10 ³ hours
(+70°C)		using MIL-HDBK 217F	170 x 10 ³ hours

Certifications

EN General Safety Report: PS-R7219C1 EN60950-1:2001 + A11:2004

Notes

Note 1: Maximum capacitive load is defined as the capacitive load that will allow start up in under 1 second without damage to the converter

Note 2: The RY-SCP/DCP series require a minimum of 10% loading on the output to maintain specified regulation. Operating under un-load condition will not damage these devices, however they may not meet all listed specifications.

ECONOLINE

DC/DC-Converter

with 3 year Warranty

RECOM

1 Watt

SIP7

Single & Dual Output

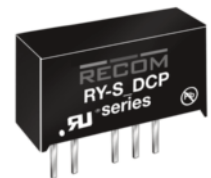

EN-60950-1 Certified

RY-S_DCP

Derating-Graph (Ambient Temperature)

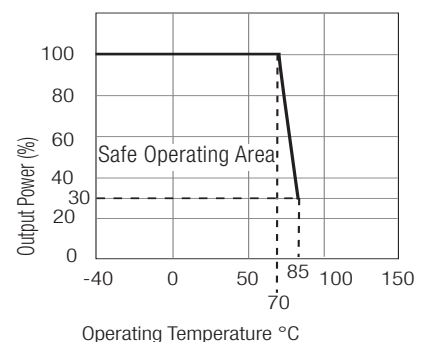

**Any data referred to in this datasheet are of indicative nature and based on our practical experience only. For further details, please refer to our Application Notes.

Refer to Application Notes

Typical Characteristics

RY-xx05SCP

RY-xx05DCP

RY-1212DCP RY-1515DCP

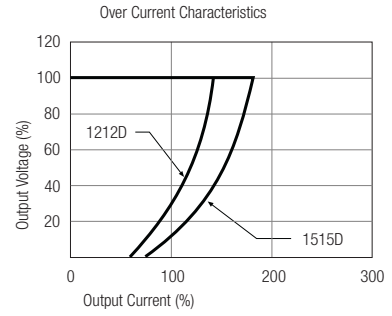
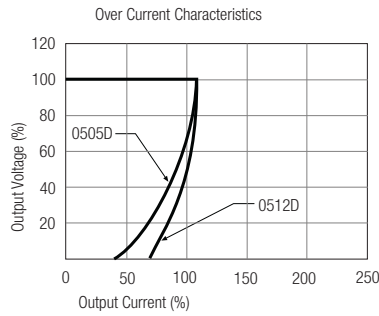
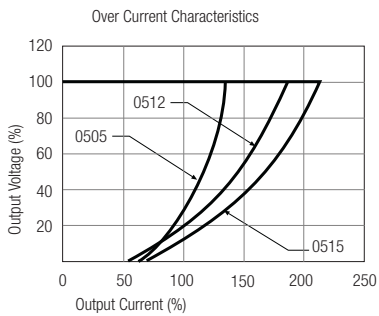
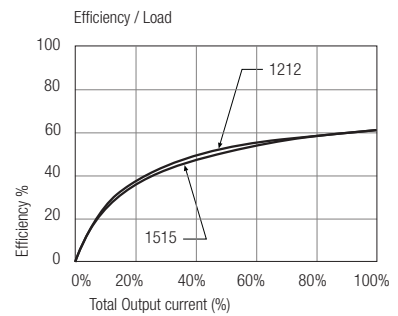
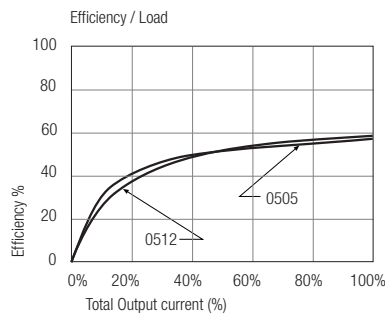
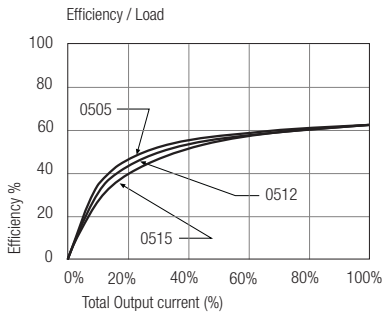

Package Style and Pinning (mm)

7 PIN SIP Package

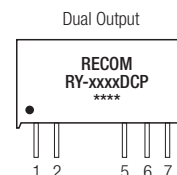
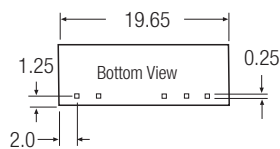
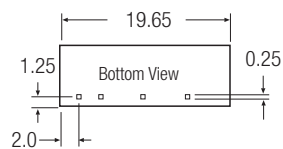
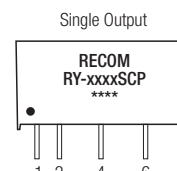
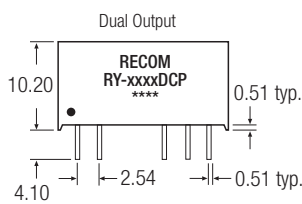
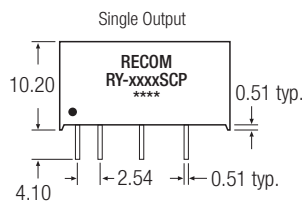

Recommended Footprint Details

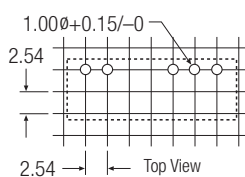
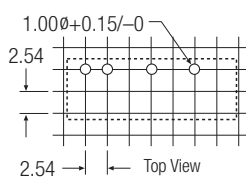

RY-S/DCP Pin Connections

Pin #	Single	Dual
1	+Vin	+Vin
2	-Vin	-Vin
4	-Vout	No Pin
5	No Pin	-Vout
6	+Vout	Com XX.X ± 0.5 mm
7	No Pin	+Vout XX.XX ± 0.25 mm

The product information and specifications are subject to change without prior notice. All products are designed for non-safety critical commercial and industrial applications. The Buyer agrees to implement safeguards that anticipate the consequences of any failures that might cause harm, loss of life and/or damage property.

Features

Regulated Converters

- 2:1 and 4:1 Wide Input Voltage Ranges
- 1kVDC, 2kVD or 3kVDC Isolation
- UL94V-0 Package Material
- Certified for Medical Applications
- Continuous Short Circuit Protection
- Low Noise
- No External Capacitor needed
- Efficiency to 83 %

Description

High-power-density, an industrial temperature range of -40°C to +85°C and extra features like On-Off-control are just some of the characteristics of this converter, ideal for highly sophisticated industrial-designs. The RSO series is available with isolation of 2kV or 3kV by choosing option "/H2" or "/H3" in which case it is also ideal for medical applications which additionally require EN-60601-1 certification. The standard version offers 2:1 input voltage range, while the "Z" version features 4:1 input voltage range, which includes an input voltage range covering both 5V and 12V supplies.

Selection Guide

Part Number	Input Voltage Range (VDC)	Rated Output Voltage (VDC)	Output Current (mA)	Efficiency typ. (%)	Max Capacitive Load ⁽¹⁾
SIP8					
RSO-xx3.3S*	4.5-9**, 9-18 18-36, 36-72	3.3	300	68-72 70	3300µF
RSO-xx05S*	4.5-9**, 9-18 18-36, 36-72	5	200	73-75 75-78	1200µF
RSO-xx09S*	4.5-9**, 9-18 18-36, 36-72	9	111	74-78 78-81	680µF
RSO-xx12S*	4.5-9**, 9-18 18-36, 36-72	12	83	75-80 80-83	680µF
RSO-xx15S*	4.5-9**, 9-18 18-36, 36-72	15	67	75-80 80-83	680µF
RSO-xx3.3D*	4.5-9**, 9-18 18-36, 36-72	±3.3	±150	68-72 70	±1500µF
RSO-xx05D*	4.5-9**, 9-18 18-36, 36-72	±5	±100	73-75 75-76	±470µF
RSO-xx09D*	4.5-9**, 9-18 18-36, 36-72	±9	±56	74-78 78	±470µF
RSO-xx12D*	4.5-9**, 9-18 18-36, 36-72	±12	±42	75-79 79-80	±330µF
RSO-xx15D*	4.5-9**, 9-18 18-36, 36-72	±15	±34	75-79 79-80	±330µF
RSO-xx3.3SZ*	9-36 18-72	3.3	300	68-70 70	3300µF
RSO-xx05SZ*	4.5-18**, 9-36 18-72	5	200	73-78 75	1200µF
RSO-xx09SZ*	4.5-18**, 9-36 18-72	9	111	75-81 78	680µF
RSO-xx12SZ*	4.5-18**, 9-36 18-72	12	83	77-83 80	680µF
RSO-xx15SZ*	4.5-18**, 9-36 18-72	15	67	78-83 80	680µF
RSO-xx3.3DZ*	9-36 18-72	±3.3	±150	70-74 70	±1500µF
RSO-xx05DZ*	4.5-18**, 9-36 18-72	±5	±100	73-77 75	±470µF
RSO-xx09DZ*	4.5-18**, 9-36 18-72	±9	±56	74-78 78	±470µF
RSO-xx12DZ*	4.5-18**, 9-36 18-72	±12	±42	75-80 80	±330µF
RSO-xx15DZ*	4.5-18**, 9-36 18-72	±15	±34	75-80 80	±330µF

No suffix is standard isolation (1kVDC) e.g, RSO-0505S

*add suffix /H2 or /H3 for 2kVDC or 3kVDC isolation, e.g, RSO-0505S/H2, RSO-0505DZ/H3

** derate to 75% if Vin<5V, 12V 4:1 input also requires an external 10µF input capacitor.

ECONOLINE

DC/DC-Converter

with 3 year Warranty

RECOM

1 Watt SIP8 Isolated Single & Dual Output



EN-60950-1 Certified
EN-60601-1 Certified*
(* /H suffix)

RSO

Derating-Graph (Ambient Temperature)

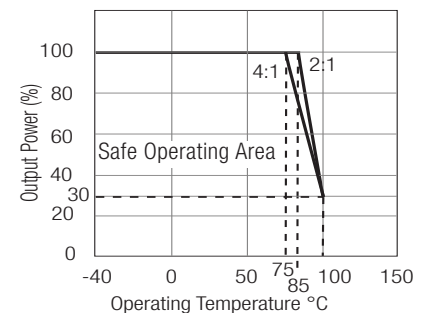

2:1 Input (RSO-S/D)
xx = 4.5-9Vin = 05
xx = 9-18Vin = 12
xx = 18-36Vin = 24
xx = 36-72Vin = 48

4:1 Input (RSO-SZ/DZ)
xx = 4.5-18Vin = 12
xx = 9-36Vin = 24
xx = 18-72Vin = 48

Refer to Application Notes

Specifications (Core Operating Area) measured at $T_A = 25^\circ\text{C}$, nominal input voltage, full load and after warm-up time unless otherwise specified

Input Voltage Range	2:1 and 4:1		
Output Voltage Accuracy	±2% typ.		
Line Voltage Regulation	2:1	±0.2% max.	
	4:1	±0.5% max.	
Load Voltage Regulation	2:1	±0.4% max.	
(10% to 100% full load)	4:1	±0.5% typ.	
Minimum Load	10% ⁽²⁾		
Output Ripple and Noise (20MHz limited)	50mVp-p max.		
Operating Frequency	2:1	200kHz min. / 500kHz max.	
	4:1	100kHz min. / 800kHz max.	
Efficiency at Full Load	See Selection Guide		
Quiescent Current	RSO-05xxS_D, SZ_DZ	40mA typ.	
Nominal input Voltage	RSO-12xxS_D	32mA typ.	
(Standard, /H2 and /H3)	RSO-24xxS_D, SZ_DZ	25mA typ.	
	RSO-48xxS_D, SZ_DZ	15mA typ.	
CTRL Pin drive current /see Notes)	3mA typ, 6mA max.		
Quiescent Input Current when Converter is OFF	10mA max.		
Isolation Voltage	Standard	(tested for 1 second) (rated for 1 minute**)	1000VDC 500VAC / 60Hz
	/H2 Version	(tested for 1 second) (rated for 1 minute**)	2000VDC 1000VAC / 60Hz
	/H3 Version	(tested for 1 second) (rated for 1 minute**)	3000VDC 1500VAC / 60Hz
Isolation Capacitance	Standard	2:1 Single	10pF min. / 40pF typ. / 60pF max.
Isolation Capacitance	/H2 and /H3	2:1 Single	5pF min. / 30pF typ. / 60pF max.
Isolation Capacitance	Standard	2:1 Dual	120pF min. / 170pF typ. / 250pF max.
Isolation Capacitance	/H2 and /H3	2:1 Dual	5pF min. / 30pF typ. / 60pF max.
Isolation Capacitance	Standard	4:1 Single/Dual	200pF max.
Isolation Capacitance	/H2 and /H3	4:1 Single/Dual	30pF max.
Isolation Resistance	>1GΩ min.		
Short Circuit Protection	Continuous		
Operating Temperature Range (free air convection)	-40°C to +85°C (see Graph)		
Storage Temperature Range	-55°C to +125°C		
Relative Humidity	95% RH		
Package Weight	4.7g		
Packing Quantity	22 pcs per Tube		
MTBF (+25°C)	} Detailed Information see Application Notes chapter "MTBF"	using MIL-HDBK 217F	1685 x 10 ³ hours
(+85°C)		using MIL-HDBK 217F	254 x 10 ³ hours
Certifications			
EN General Safety	Report: SPCLVD1212007	EN60950-1:2006 + A11:2009+A1:2010+A12:2011	
EN Medical Safety	Report: MDD1205098-3 + RM1205098-3	IEC/EN 60601-1 3rd Edition	Medical Report + ISO14971 Risk Assessment

RSO-24xxS

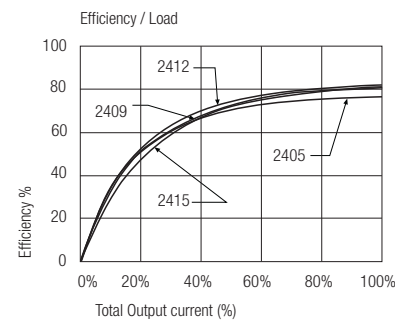

RSO-1205SZ

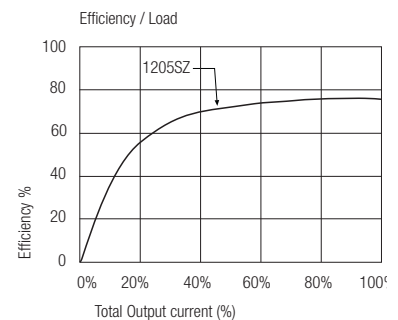

**Any data referred to in this datasheet are of indicative nature and based on our practical experience only. For further details, please refer to our Application Notes.

Notes

- Note 1: Maximum capacitive load is defined as the capacitive load that will allow start up in under 1 second without damage to the converter
- Note 2: The RSO series require a minimum of 10% loading on the output to maintain specified regulation. Operating under un-load condition will not damage these devices, however they may not meet all listed specifications.

Typical Application

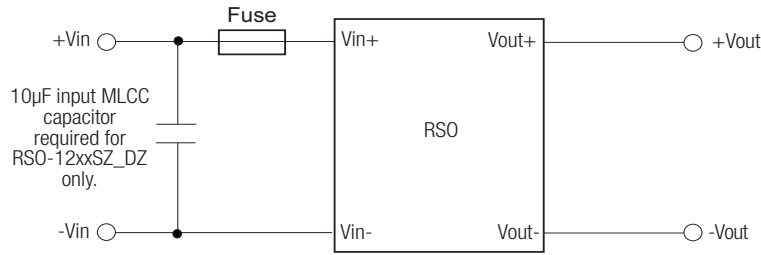

Package Style and Pinning (mm)

8 PIN SIP Package

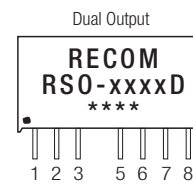
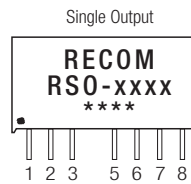
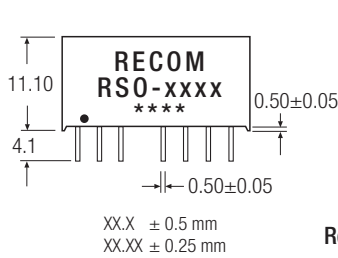

Recommended Footprint Details

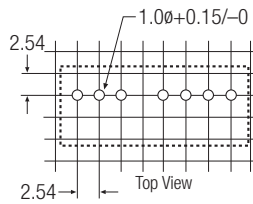
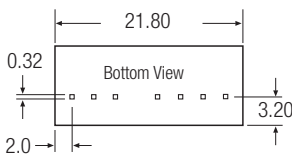

Pin Connections

Pin #	Single	Dual
1	-Vin	-Vin
2	+Vin	+Vin
3	CTRL	CTRL
5	NC	NC
6	+Vout	+Vout
7	-Vout	Com
8	NC*	-Vout

NC = No Connection

NC* = NC, but no external Connection allowed.

CTRL Examples

Pin 8 (NC*) This pin is used internally and must have no external connection.

Pin 5 (NC) Not connected internally.

Pin 3 (CTRL)

This pin provides an Off function which puts the converter into a low power mode. When the pin is 'high' the converter is OFF and when the pin is high 'Z' the converter is ON. There is no allowed low state for this pin.

ON/OFF CONTROL

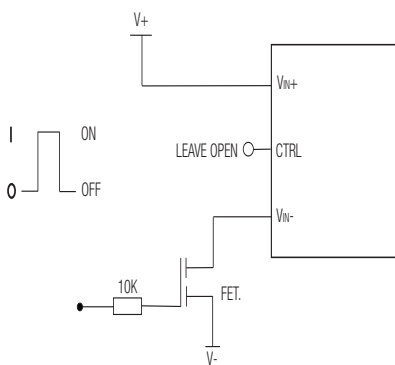

I = 3V
0 = 0.5V or GND

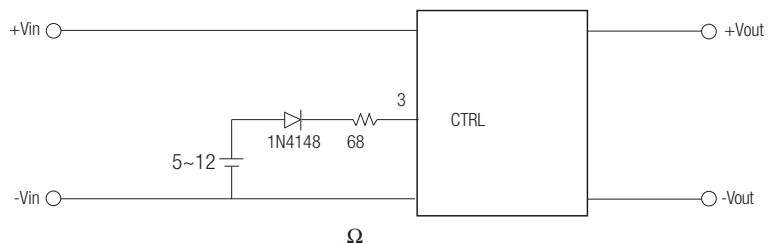

Remote ON/OFF

ON: open or high impedance

OFF: external 5~12 Vdc and 1N4148+ 68Ω resistor

Features

Regulated Converters

- 2:1 and 4:1 Wide Input Voltage Ranges
- 1kVDC, 2kVDC & 3kVDC Isolation
- UL94V-0 Package Material
- Continuous Short Circuit Protection
- Low Noise
- No External Capacitor needed
- Efficiency to 83%

Description

High power-density, an industrial temperature range of -40°C to +85°C and extra features like Remote-On-Off- control are just some of the characteristics of this converter, ideal for highly sophisticated industrial designs. The RS series is available with isolation of 2kV or 3kV by choosing option "/H2" or "/H3" in which case it is also ideal for medical applications which additionally require EN-60601-1 certification.

Selection Guide 5V, 12V, 24V and 48V Input Types

Part Number	Input Voltage Range (VDC)	Rated Output Voltageat (VDC)	Output Current Full Load (mA)	Efficiency typ. (%)	Max Capacitive Load
SIP8					
	RS-xx3.3S (H2/H3)	4.5-9, 9-18 18-36, 36-72	3.3	500	68-69 70-73
RS-xx05S (H2/H3)	4.5-9, 9-18 18-36, 36-72	5	400	73-75 78	1000µF
	RS-xx09S (H2/H3)	4.5-9, 9-18 18-36, 36-72	9	222	74-78 81
RS-xx12S (H2/H3)	4.5-9, 9-18 18-36, 36-72	12	166	75-80 83	1000µF
	RS-xx15S (H2/H3)	4.5-9, 9-18 18-36, 36-72	15	134	75-80 83
RS-xx3.3D (H2/H3)	4.5-9, 9-18 18-36, 36-72	±3.3	±250	68-69 70-73	±2200µF
	RS-xx05D (H2/H3)	4.5-9, 9-18 18-36, 36-72	±5	±200	73-75 78
RS-xx09D (H2/H3)	4.5-9, 9-18 18-36, 36-72	±9	±111	74-78 81	±680µF
	RS-xx12D (H2/H3)	4.5-9, 9-18 18-36, 36-72	±12	±83	75-80 83
RS-xx15D (H2/H3)	4.5-9, 9-18 18-36, 36-72	±15	±67	75-80 83	±680µF
	RS-xx3.3SZ (H2/H3)	9-36 18-72	3.3	500	75 75
RS-xx05SZ (H2/H3)	9-36 18-72	5	400	80 80	1000µF
	RS-xx09SZ (H2/H3)	9-36 18-72	9	222	80 80
RS-xx12SZ (H2/H3)	9-36 18-72	12	166	83 83	1000µF
	RS-xx15SZ (H2/H3)	9-36 18-72	15	134	84 84
RS-xx3.3DZ (H2/H3)	9-36 18-72	±3.3	±250	73 73	±2200µF
	RS-xx05DZ (H2/H3)	9-36 18-72	±5	±200	77 77
RS-xx09DZ (H2/H3)	9-36 18-72	±9	±111	80 80	±680µF
	RS-xx12DZ (H2/H3)	9-36 18-72	±12	±83	81 81
RS-xx15DZ (H2/H3)	9-36 18-72	±15	±67	83 83	±680µF

No suffix is standard isolation (1kVDC) e.g, RS-0505S

*add suffix /H2 or /H3 for 2kVDC or 3kVDC isolation, e.g, RS-0505S/H2, RS-0505DZ/H3

ECONOLINE

DC/DC-Converter

with 3 year Warranty

RECOM

2 Watt SIP8 Isolated Single & Dual Output



EN-60950-1 Certified
EN-60601-1 Certified*
(* /H suffix)

RS

Derating-Graph (Ambient Temperature)

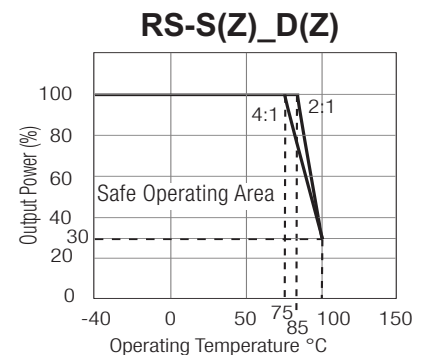

2:1 Input
(RS-S/D)
xx = 4.5-9Vin = 05
xx = 9-18Vin = 12
xx = 18-36Vin = 24
xx = 36-72Vin = 48

4:1 Input
(RS-SZ/DZ)
xx = 9-36Vin = 24
xx = 18-72Vin = 48

Refer to Application Notes

Specifications (measured at $T_A = 25^\circ\text{C}$, nominal input voltage, full load and after warm-up time unless otherwise specified)

Input Voltage Range			2:1 and 4:1
Output Accuracy			$\pm 2\%$ typ.
Line Voltage Regulation			$\pm 0.5\%$ max.
Load Voltage Regulation		20%-100% Load	$\pm 0.5\%$ max.
Minimum Load			10% ⁽²⁾
Output Ripple and Noise (20MHz limited)			50mVp-p max.
Switching Frequency		Full Load	100kHz min. / 300kHz max.
Efficiency at Full Load			See Selection Guide
Quiescent Current		RS-05xxS_D	40mA typ.
Nominal input Voltage (Standard, /H2 and /H3)		RS-12xxS_D	32mA typ.
		RS-24xxS_D, SZ_DZ	25mA typ.
		RS-48xxS_D, SZ_DZ	15mA typ.
Isolation Voltage	Standard	(tested for 1 second)	1000VDC
		(rated for 1 minute**)	500VAC / 60Hz
	/H2 Version	(tested for 1 second)	2000VDC
		(rated for 1 minute**)	1000VAC / 60Hz
/H3 Version	(tested for 1 second)	3000VDC	
	(rated for 1 minute**)	1500VAC / 60Hz	
Isolation Capacitance	Standard	2:1 Single	10pF min. / 40pF typ. / 60pF max.
Isolation Capacitance	/H2 and /H3	2:1 Single	5pF min. / 30pF typ. / 60pF max.
Isolation Capacitance	Standard	2:1 Dual	120pF min. / 170pF typ. / 250pF max.
Isolation Capacitance	/H2 and /H3	2:1 Dual	5pF min. / 30pF typ. / 60pF max.
Isolation Capacitance	Standard	4:1 Single/Dual	200pF max.
Isolation Capacitance	/H2 and /H3	4:1 Single/Dual	30pF max
Isolation Resistance			1G Ω min.
Short Circuit Protection			Continuous
Operating Temperature Range (No Derating)		2:1	-40°C to +85°C
		4:1	-40°C to +75°C
Storage Temperature Range			-55°C to +125°C
Relative Humidity			95% RH
Package Weight			4.7g
Packing Quantity			22 pcs per Tube
MTBF (+25°C) (+85°C)	} Detailed Information see Application Notes chapter "MTBF"	using MIL-HDBK 217F	1398 x 10 ³ hours
		using MIL-HDBK 217F	210 x 10 ³ hours
Certifications	EN General Safety	Report: SPCLVD1212007	EN60950-1:2006 + 11:2009+A1:2010+A12:2011
	EN Medical Safety	Report: MDD1205098-3 + RM1205098-3	IEC/EN 60601-1 3rd Edition Medical Report + ISO14971 Risk Assessment

**Any data referred to in this datasheet are of indicative nature and based on our practical experience only. For further details, please refer to our Application Notes.

Notes

- Note 1: Maximum capacitive load is defined as the capacitive load that will allow start up in under 1 second without damage to the converter
- Note 2: The RS series require a minimum of 10% loading on the output to maintain specified regulation. Operating under un-load condition will not damage these devices, however they may not meet all listed specifications.

Typical Characteristics

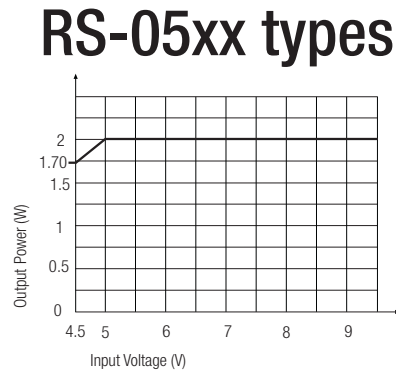
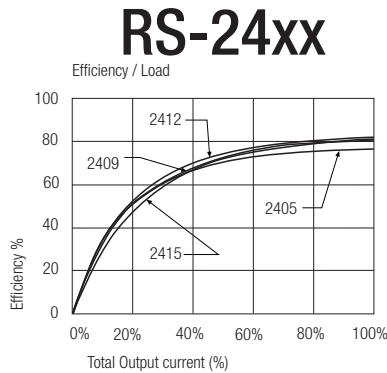

Package Style and Pinning (mm)

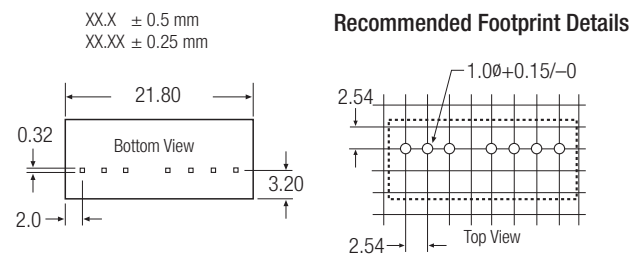
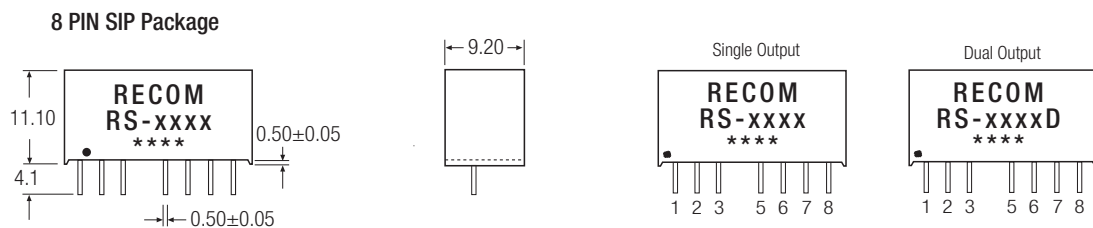

Pin Connections

Pin #	Single	Dual
1	-Vin	-Vin
2	+Vin	+Vin
3	CTRL	CTRL
5	NC	NC
6	+Vout	+Vout
7	-Vout	Com
8	NC*	-Vout

NC = No Connection

NC* = NC, but no external Connection allowed.

Pin 8 (NC*) This pin is used internally and must have no external connection.

Pin 5 (NC) Not connected internally.

Pin 3 (CTRL)

This pin provides an Off function which puts the converter into a low power mode. When the pin is 'high' the converter is OFF and when the pin is high 'Z' the converter is ON. There is no allowed low state for this pin.

Application Examples

ON/OFF CONTROL

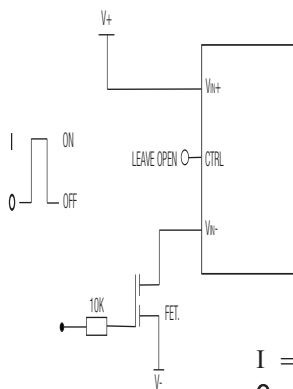

I = 3V
0 = 0.5V or GND

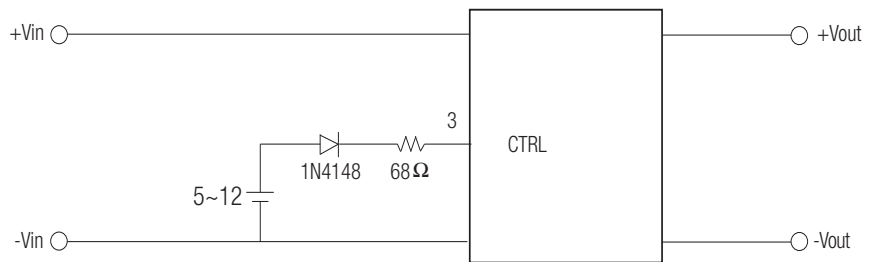

Remote ON/OFF

ON: open or high impedance

OFF: external 5~12 Vdc and 1N4148+ 68Ω resistor

The product information and specifications are subject to change without prior notice. All products are designed for non-safety critical commercial and industrial applications. The Buyer agrees to implement safeguards that anticipate the consequences of any failures that might cause harm, loss of life and/or damage property.

Features

Regulated Converters

- 2:1 Wide Range Voltage Input
- 1kVDC, 2kVDC and 3kVDC Isolation
- Approved for Medical Applications
- Continuous Short Circuit Protection
- Low Ripple and Noise
- DIP16, mini DIP16 and SMD Cases Styles
- Efficiency to 83 %

Description

High power-density, 2:1 input voltage range and a wide temperature range of -40°C to +85°C are just some of the characteristics of this versatile DIP16 converter, ideal for highly sophisticated industrial and medical designs where a regulated converter is required but space is at a premium. Three different case styles and isolation options are available.

Selection Guide

Part Number	Input Voltage Range (VDC)	Rated Output Voltage (VDC)	Output Current Full Load (mA)	Efficiency typ./nom Vin (%)	Max Capacitive Load ⁽¹⁾
RW2-053.3S (H2/H3)	4.5 - 9	3.3	500	68	4700µF
RW2-0505S (H2/H3)	4.5 - 9	5	400	73	1000µF
RW2-0512S (H2/H3)	4.5 - 9	12	166	75	1000µF
RW2-0515S (H2/H3)	4.5 - 9	15	134	75	1000µF
RW2-123.3S (H2/H3)	9 - 18	3.3	500	69	4700µF
RW2-1205S (H2/H3)	9 - 18	5	400	75	1000µF
RW2-1212S (H2/H3)	9 - 18	12	166	80	1000µF
RW2-1215S (H2/H3)	9 - 18	15	134	80	1000µF
RW2-243.3S (H2/H3)	18 - 36	3.3	500	70	4700µF
RW2-2405S (H2/H3)	18 - 36	5	400	78	1000µF
RW2-2412S (H2/H3)	18 - 36	12	166	83	1000µF
RW2-2415S (H2/H3)	18 - 36	15	134	83	1000µF
RW2-483.3S (H2/H3)	36 - 72	3.3	500	73	4700µF
RW2-4805S (H2/H3)	36 - 72	5	400	76	1000µF
RW2-4812S (H2/H3)	36 - 72	12	166	81	1000µF
RW2-4815S (H2/H3)	36 - 72	15	134	81	1000µF
RW2-0505D (H2/H3)	4.5 - 9	±5	±200	73	±680µF
RW2-0509D (H2/H3)	4.5 - 9	±9	±111	74	±680µF
RW2-0512D (H2/H3)	4.5 - 9	±12	±83	75	±680µF
RW2-0515D (H2/H3)	4.5 - 9	±15	±67	75	±680µF
RW2-1205D (H2/H3)	9 - 18	±5	±200	75	±680µF
RW2-1209D (H2/H3)	9 - 18	±9	±111	78	±680µF
RW2-1212D (H2/H3)	9 - 18	±12	±83	80	±680µF
RW2-1215D (H2/H3)	9 - 18	±15	±67	80	±680µF
RW2-2405D (H2/H3)	18 - 36	±5	±200	78	±680µF
RW2-2409D (H2/H3)	18 - 36	±9	±111	81	±680µF
RW2-2412D (H2/H3)	18 - 36	±12	±83	83	±680µF
RW2-2415D (H2/H3)	18 - 36	±15	±67	83	±680µF
RW2-4805D (H2/H3)	36 - 72	±5	±200	78	±680µF
RW2-4809D (H2/H3)	36 - 72	±9	±111	81	±680µF
RW2-4812D (H2/H3)	36 - 72	±12	±83	83	±680µF
RW2-4815D (H2/H3)	36 - 72	±15	±67	83	±680µF

Standard Isolation is 1kVDC. Add suffix **“H2”** for 2kVDC Isolation, **“H3”** for 3kVDC Isolation. Add no suffix for standard case style, **“/SMD”** for SMD package or **“/B”** for smaller case size e.g. RW2-0505S/H3, RW2-0505D/H2/SMD or RW2-0505S/B

Notes

- Note 1: Maximum capacitive load is defined as the capacitive load that will allow start up in under 1second without damage to the converter
- Note 2: The RW2 series require a minimum of 10% loading on the output to maintain specified regulation. Operating under un-load condition will not damage these devices, however they may not meet all listed specifications.

ECONOLINE

DC/DC-Converter

with 3 year Warranty

RECOM

2 Watt

DIP16, Mini

DIP16 & SMD

Single & Dual

Output



EN-60950-1 Certified (All Suffixes)

EN-60601-1 Certified* (* /H suffix)

RW2

Derating-Graph

(Ambient Temperature)

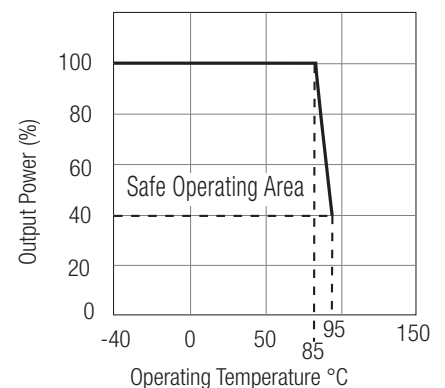

Refer to Application Notes

Electrical Specifications (measured at $T_A = 25^\circ\text{C}$, at nominal input voltage and rated output current unless otherwise specified)

Input Voltage Range		2:1	
Output Accuracy		$\pm 2\%$ typ.	
Line Voltage Regulation		$\pm 0.5\%$ max.	
Load Voltage Regulation	(20% to 100% full load)	$\pm 0.5\%$ typ.	
Minimum Load		10% ⁽²⁾	
Output Ripple and Noise (20MHz limited)		50mVp-p max.	
Switching Frequency (at full Load)		100kHz min. / 700kHz max.	
Efficiency at Full Load		70% min. / 80% typ.	
Isolation Voltage	(tested for 1 second)	1000VDC	
	(rated for 1 minute*)	500VAC / 60Hz	
H2-Suffix	(tested for 1 second)	2000VDC	
	(rated for 1 minute*)	1000VAC / 60Hz	
H3-Suffix	(tested for 1 second)	3000VDC	
	(rated for 1 minute*)	1500VAC / 60Hz	
Isolation Capacitance		30pF max.	
Isolation Resistance		1G Ω min.	
Short Circuit Protection		Continuous	
Operating Temperature Range		-40°C to +85°C (see Graph)	
Storage Temperature Range		-55°C to +125°C	
Case Temperature		100°C max.	
Relative Humidity		95% RH	
Package Weight		6.4g	
Packing Quantity	Case Style A, SMD	20 pcs per tube	
	Case Style B	22 pcs per Tube	
MTBF (+25°C)	} For Detailed Information see Application Notes chapter "MTBF"	using MIL-HDBK 217F	4366 x10 ³ hours
(+85°C)		using MIL-HDBK 217F	658 x10 ³ hours

**Any data referred to in this datasheet are of indicative nature and based on our practical experience only. For further details, please refer to our Application Notes.

Package Style and Pinning (mm)

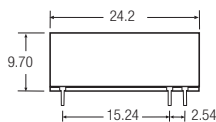

Case Style A

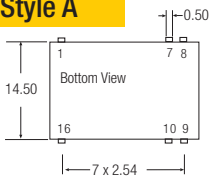

16 Pin DIP Package

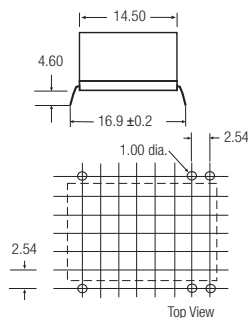

Recommended Footprint Details

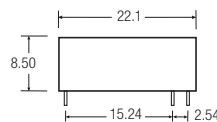

Case Style B

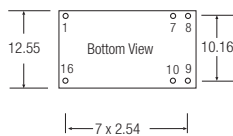

16 Pin Mini-DIP Package

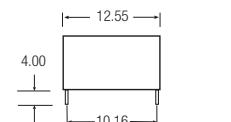

Recommended Footprint Details

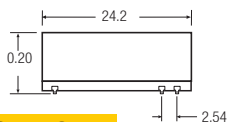

SMD Case Style

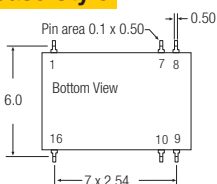

16 Pin SMD Package

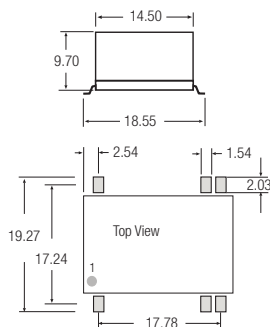

Recommended Pad Details

Pin Connections (All Case Styles)

Pin #	Single	Dual
1	-Vin	-Vin
7	NC	NC
8	NC	Com
9	+Vout	+Vout
10	-Vout	-Vout
16	+Vin	+Vin

XX.X ± 0.5 mm
XX.XX ± 0.35 mm

Certifications

EN General Safety Report: SPCLVD1212007 EN60950-1:2006 + A12:2011
 EN Medical Safety Report: MDD1205098-3 + RM1205098-3
 IEC/EN 60601-1 3rd Edition Medical Report + ISO14971 Risk Assessment

The product information and specifications are subject to change without prior notice. All products are designed for non-safety critical commercial and industrial applications. The Buyer agrees to implement safeguards that anticipate the consequences of any failures that might cause harm, loss of life and/or damage property.

Features

Regulated Converters

- 2:1 and 3:1 Wide Input Voltage Ranges
- 1kVDC, 2kVDC and 3kVDC Isolation
- UL94V-0 Package Material
- Continuous Short Circuit Protection
- Low Ripple and Noise
- Remote On/Off Control
- Efficiency to 83 %

Description

Very high power density, 2:1 or 3:1 input voltage range and a wide operating temperature range -40°C to +71°C and extra features such as On/Off control are just some of the characteristics of this converter which is ideal for highly sophisticated industrial designs. The RS3 is available with 2kV or 3kV isolation options (1kVDC is standard)

Selection Guide

Part Number	Input Voltage Range (VDC)	Rated Output Voltage (VDC)	Output Current Full Load (mA)	Efficiency typ. (%)	Max Capacitive Load ⁽¹⁾
RS3-xx3.3S (H2/H3)	4.5-9, 9-18 18-36, 36-72	3.3	600	73-75 77-78	4700µF
RS3-xx05S (H2/H3)	4.5-9, 9-18 18-36, 36-72	5	600	76-79 80-81	4700µF
RS3-xx09S (H2/H3)	4.5-9, 9-18 18-36, 36-72	9	333	77-80 81-82	3300µF
RS3-xx12S (H2/H3)	4.5-9, 9-18 18-36, 36-72	12	250	80-81 83	2200µF
RS3-xx15S (H2/H3)	4.5-9, 9-18 18-36, 36-72	15	200	80-81 83	2200µF
RS3-xx3.3D (H2/H3)	4.5-9, 9-18 18-36, 36-72	±3.3	±300	73-75 75	±2200µF
RS3-xx05D (H2/H3)	4.5-9, 9-18 18-36, 36-72	±5	±300	76-80 80-81	±2200µF
RS3-xx09D (H2/H3)	4.5-9, 9-18 18-36, 36-72	±9	±167	77-81 81	±2200µF
RS3-xx12D (H2/H3)	4.5-9, 9-18 18-36, 36-72	±12	±125	78-83 83	±1000µF
RS3-xx15D (H2/H3)	4.5-9, 9-18 18-36, 36-72	±15	±100	79-83 83	±1000µF
RS3-xx3.3SZ (H2/H3)	9-27 20-60	3.3	600	73 74	4700µF
RS3-xx05SZ (H2/H3)	9-27 20-60	5	600	76-79 78	4700µF
RS3-xx09SZ (H2/H3)	9-27 20-60	9	333	77 79	3300µF
RS3-xx12SZ (H2/H3)	9-27 20-60	12	250	80 80	2200µF
RS3-xx15SZ (H2/H3)	9-27 20-60	15	200	80 80	2200µF
RS3-xx3.3DZ (H2/H3)	9-27 20-60	±3.3	±300	73 74	±2200µF
RS3-xx05DZ (H2/H3)	9-27 20-60	±5	±300	77 78	±2200µF
RS3-xx09DZ (H2/H3)	9-27 20-60	±9	±167	79 79	±2200µF
RS3-xx12DZ (H2/H3)	9-27 20-60	±12	±125	80 80	±1000µF
RS3-xx15DZ (H2/H3)	9-27 20-60	±15	±100	80 80	±1000µF

No suffix is standard isolation (1kVDC) e.g, RS3-0505S

*add suffix /H2 or /H3 for 2kVDC or 3kVDC isolation, e.g, RS3-0505S/H2, R3S-0505DZ/H3

ECONOLINE

DC/DC-Converter

with 3 year Warranty

RECOM

3 Watt SIP8 Isolated Single & Dual Output



EN-60950-1 Certified
EN-60601-1 Certified*
(* /H suffix)

RS3

Derating-Graph

(Ambient Temperature)

RS3-(Z)S_D

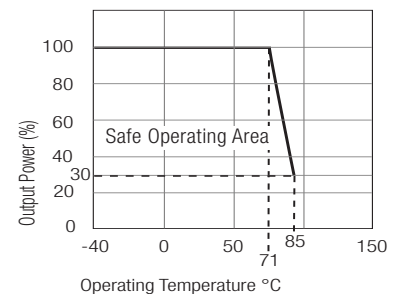

2:1 Input
(RS3-S/D)

xx = 4.5-9Vin = 05
xx = 9-18Vin = 12
xx = 18-36Vin = 24
xx = 36-72Vin = 48

3:1 Input
(RS3-SZ/DZ)

xx = 9-27Vin = 24
xx = 20-60Vin = 48

Refer to Application Notes

Electrical Specifications (measured at $T_A = 25^\circ\text{C}$, at nominal input voltage and rated output current unless otherwise specified)

Input Voltage Range		2:1 and 3:1	
Output Accuracy	Nominal V_{in} and full load	$\pm 2\%$ typ.	
Line Voltage Regulation	LL to HL, full load	$\pm 0.5\%$ max.	
Load Voltage Regulation	20% to 100% full load	$\pm 0.5\%$ typ.	
Minimum Load		10% ⁽²⁾	
Output Ripple and Noise	20MHz limited	50mVp-p max.	
Switching Frequency	20% to 100% full load	200kHz typ.	
Efficiency at Full Load		see Selection Guide	
Quiescent Current	RS3-05xxS_D	35mA typ.	
Nominal input Voltage (Standard, /H2 and /H3)	RS3-12xxS_D	25mA typ.	
	RS3-24xxS_D, SZ_DZ	20mA typ.	
	RS3-48xxS_D, SZ_DZ	10mA typ.	
Isolation Voltage	Standard	(tested for 1 second) (rated for 1 minute*) 1000VDC 500VAC / 60Hz	
	/H2 Version	(tested for 1 second) (rated for 1 minute*) 2000VDC 1000VAC / 60Hz	
	/H3 Version	(tested for 1 second) (rated for 1 minute*) 3000VDC 1500VAC / 60Hz	
Isolation Capacitance (2:1 and 3:1) (tested at 100kHz)	H1	200pF max.	
	H2/H3	30pF max.	
Isolation Resistance		1G Ω min.	
Short Circuit Protection (see note)		Continuous	
Operating Temperature Range		-40°C to $+71^\circ\text{C}$	
Storage Temperature Range		-55°C to $+125^\circ\text{C}$	
Relative Humidity		95% RH	
Package Weight		4.7g	
Packing Quantity		22 pcs per Tube	
MTBF ($+25^\circ\text{C}$) ($+71^\circ\text{C}$)	} Detailed Information see Application Notes chapter "MTBF"	using MIL-HDBK 217F	3303 x10 ³ hours
		using MIL-HDBK 217F	745 x10 ³ hours

Typical Application

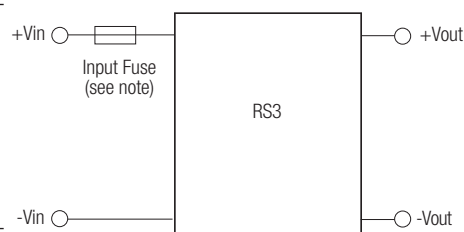

**Any data referred to in this datasheet are of indicative nature and based on our practical experience only. For further details, please refer to our Application Notes.

Certifications

EN General Safety	Report: SPCLVD1212007	EN60950-1:2006 + A11:2009+A1:2010+A12:2011
EN Medical Safety	Report: MDD1205098-3 + RM1205098-3	IEC/EN 60601-1 3rd Edition Medical Report + ISO14971 Risk Assessment

Note: To protect the converter under all fault conditions, an input fuse is required. Quick-blow fuses should be rated at 2x-3x the normal input current, time-delay fuses at 1.5x the normal input current.

Notes

- Note 1: Maximum capacitive load is defined as the capacitive load that will allow start up in under 1 second without damage to the converter
- Note 2: The RS3 series require a minimum of 10% loading on the output to maintain specified regulation. Operating under un-load condition will not damage these devices, however they may not meet all listed specifications.

Typical Characteristics

RS3-0505S

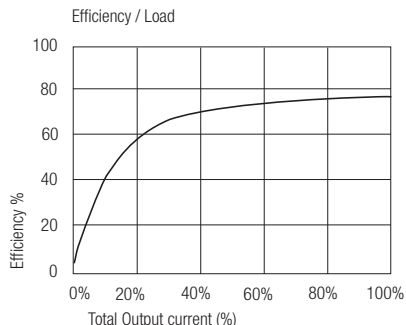

RS3-4805D

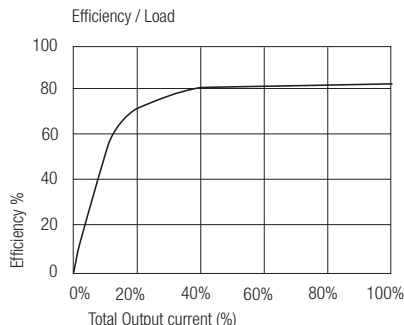

Package Style and Pinning (mm)

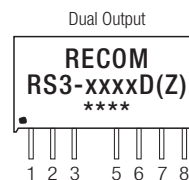
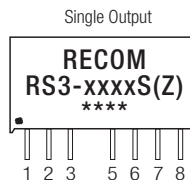
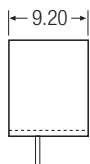
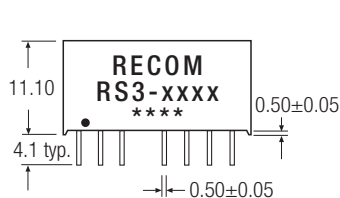

Recommended Footprint Details

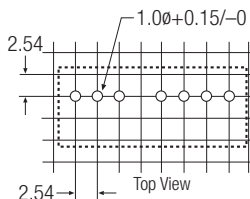
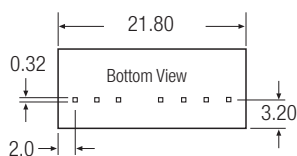

XX.X ± 0.5 mm
XX.XX ± 0.25 mm

Pin Connections

Pin #	Single	Dual
1	-Vin	-Vin
2	+Vin	+Vin
3	CTRL	CTRL
5	NC	NC
6	+Vout	+Vout
7	-Vout	Com
8	NC	-Vout

NC = No Connection

Pin 8 (NC*) This pin is used internally and must have no external connection.

Pin 5 (NC) Not connected internally.

Pin 3 (CTRL)

This pin provides an Off function which puts the converter into a low power mode. When the pin is 'high' the converter is OFF and when the pin is high 'Z' the converter is ON. There is no allowed low state for this pin.

Application Examples

ON/OFF CONTROL

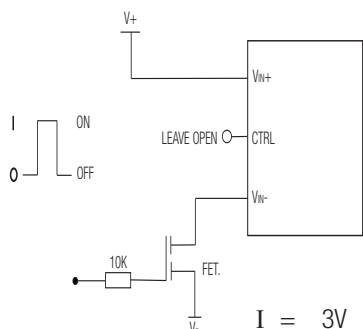

I = 3V
0 = 0.5V or GND

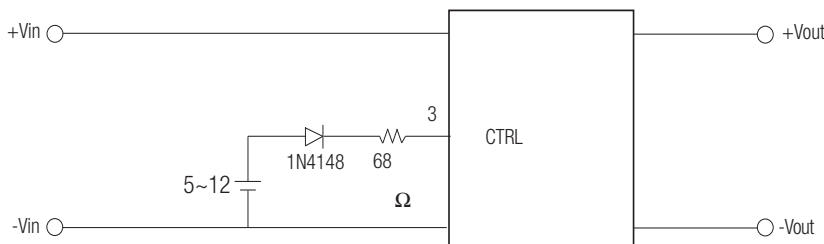

Remote ON/OFF

ON: open or high impedance
OFF: external 5~12Vdc and 1N4148+ 68Ω resistor

The product information and specifications are subject to change without prior notice. All products are designed for non-safety critical commercial and industrial applications. The Buyer agrees to implement safeguards that anticipate the consequences of any failures that might cause harm, loss of life and/or damage property.

Features

Regulated Converters

- DIP24 Low Profile Miniature Package
- 1kVDC Isolation
- Feedback Regulated Output
- 2:1 Wide Range Voltage Input
- Continuous Short Circuit Protection
- Less than 7mm Height
- SMD Pinning Option
- Efficiency to 87%

Description

The RW-S series with 2:1 input voltage ranges and max. height of 7,0 mm has been designed for the industrial automation markets. They are aimed at applications where pcb-space is at a premium so SMD pinning is also available. The converters supply the full 3 watts without additional heat-sinks over the temperature range -40°C to +80°C.

Selection Guide

Part Number DIP24 Miniature	Input Voltage (VDC)	Output Voltage (VDC)	Output Current (mA)	Efficiency (%)	Max Capacitive Load ⁽¹⁾
RW-053.3S	4.5 – 9	3.3	650	68	4700µF
RW-0505S	4.5 – 9	5	600	69	4700µF
RW-0509S	4.5 – 9	9	333	70	3300µF
RW-0512S	4.5 – 9	12	250	72	2200µF
RW-0515S	4.5 – 9	15	200	73	2200µF
RW-123.3S	9 – 18	3.3	650	70	4700µF
RW-1205S	9 – 18	5	600	73	4700µF
RW-1209S	9 – 18	9	333	78	3300µF
RW-1212S	9 – 18	12	250	79	2200µF
RW-1215S	9 – 18	15	200	79	2200µF
RW-243.3S	18 – 36	3.3	650	75	4700µF
RW-2405S	18 – 36	5	600	78	4700µF
RW-2409S	18 – 36	9	333	82	3300µF
RW-2412S	18 – 36	12	250	84	2200µF
RW-2415S	18 – 36	15	200	85	2200µF
RW-483.3S	36 – 72	3.3	650	73	4700µF
RW-4805S	36 – 72	5	600	78	4700µF
RW-4809S	36 – 72	9	333	82	3300µF
RW-4812S	36 – 72	12	250	84	2200µF
RW-4815S	36 – 72	15	200	85	2200µF

* add suffix "/SMD" for SMD package, e.g. RW-2405S/SMD

RW-05xx types

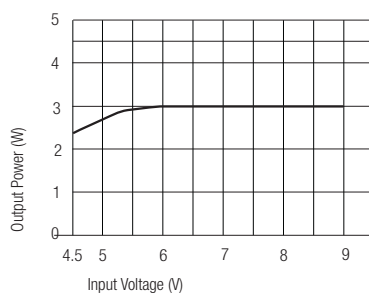

ECONOLINE

DC/DC-Converter

with 3 year Warranty

RECOM

3 Watt DIP24/SMD Low Profile Package Single Output



EN-60950-1 Certified

RW-S

Derating-Graph

(Ambient Temperature)

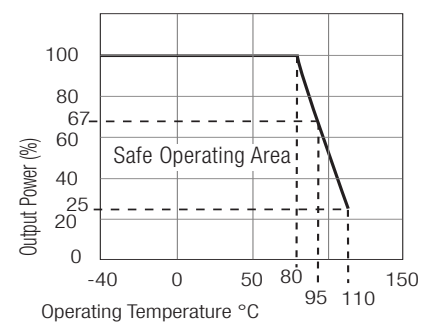

Refer to Application Notes

Specifications (Core Operating Area)

Input Voltage Range		2:1	
Output Voltage Accuracy		±2% max.	
Line Voltage Regulation		±0.2% typ.	
Load Voltage Regulation (10% to 100% full load)		±0.5% max.	
Minimum Load		10% ⁽²⁾	
Output Ripple and Noise (20MHz limited)		70mVp-p max.	
Operating Frequency		85kHz min. / 100kHz typ.	
Efficiency at Full Load		See Selection Guide	
No Load Power Consumption		250mW max.	
Isolation Voltage	(tested for 1 second) (rated for 1 minute**)	1000VDC 500VAC / 60Hz	
Isolation Capacitance		40pF min. / 60pF max.	
Isolation Resistance		1 GΩ min.	
Short Circuit Protection		Continuous	
Operating Temperature Range (free air convection)		-40°C to +80°C (see Graph)	
Storage Temperature Range		-55°C to +125°C	
Relative Humidity		95% RH	
Package Weight	DIP24	7g	
	SMD	7.7g	
Packing Quantity		15 pcs per Tube	
MTBF (+25°C)	} Detailed Information see Application Notes chapter "MTBF"	using MIL-HDBK 217F	1034 x 10 ³ hours
(+80°C)		using MIL-HDBK 217F	186 x 10 ³ hours
Certifications			
EN General Safety	Report: SPCLVD1212007	EN60950-1:2006 + A11:2009+A1:2010+A12:2011	
EN Medical Safety	Report: MDD1205098-3 + RM1205098-3	IEC/EN 60601-1 3rd Edition	Medical Report + ISO14971 Risk Assessment

**Any data referred to in this datasheet are of indicative nature and based on our practical experience only. For further details, please refer to our Application Notes.

Notes

- Note 1: Maximum capacitive load is defined as the capacitive load that will allow start up in under 1 second without damage to the converter
- Note 2: The RW-S series require a minimum of 10% loading on the output to maintain specified regulation. Operating under un-load condition will not damage these devices, however they may not meet all listed specifications.

Typical Performance

RW-1205S

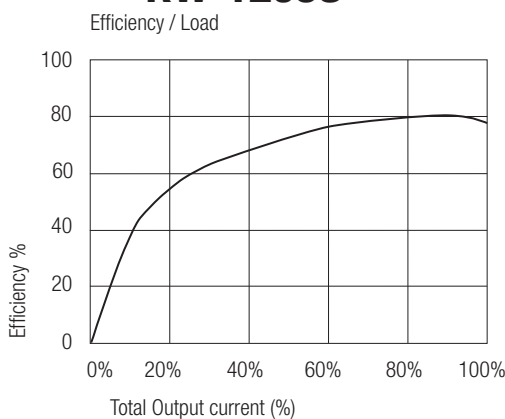

RW-2412S

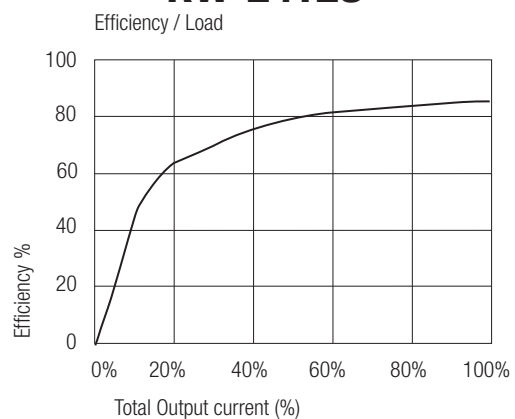

Package Style and Pinning (mm)

24 PIN DIP Miniature Package Style

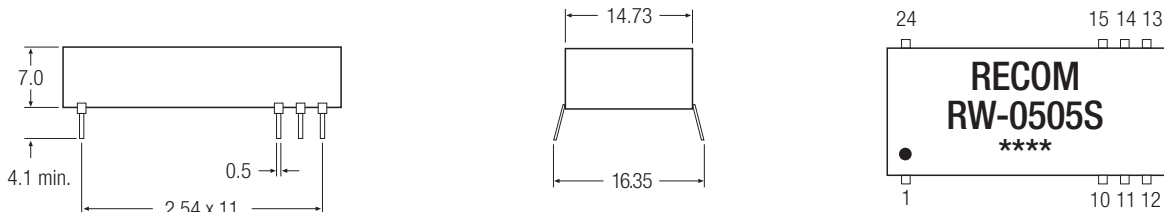

Recommended Footprint Details

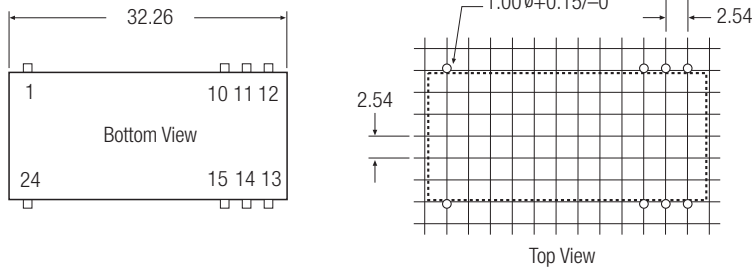

Pin Connections

Pin #	Single
1 & 24	+Vin
10 & 15	-Vout
11 & 14	+Vout
12 & 13	-Vin

NC = No Connection
XX.X ± 0.5 mm
XX.XX ± 0.25 mm

24 PIN SMD Miniature Package Style

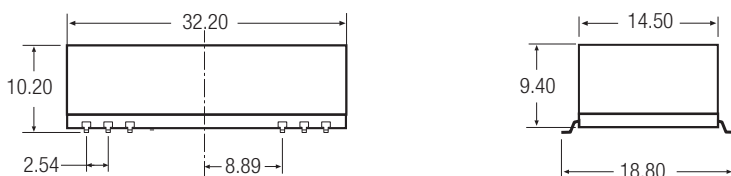

Recommended Footprint Details

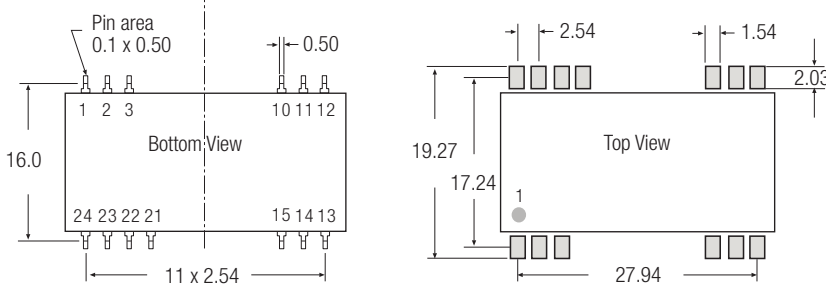

Pin Connections

Pin #	Single
1 & 24	+Vin
10 & 15	-Vout
11 & 14	+Vout
12 & 13	-Vin
others	NC

NC = No Connection
XX.X ± 0.5 mm
XX.XX ± 0.25 mm

The product information and specifications are subject to change without prior notice. All products are designed for non-safety critical commercial and industrial applications. The Buyer agrees to implement safeguards that anticipate the consequences of any failures that might cause harm, loss of life and/or damage property.

Features

Regulated Converters

- DIP24 Low Profile Package
- Dual Outputs from a Single Supply
- 2:1 Wide Range Voltage Input
- 3kVDC Isolation
- UL94V-0 Package Material
- Continuous Short Circuit Protection
- Low profile 7mm Height
- Approved for Medical Applications
- Efficiency to 85%

Description

The RW_D series with 2:1 input voltage ranges and maximum height of 7,0 mm has been designed for industrial automation and medical markets where a dual output rail needs to be generated from a single rail source. The converters supply the full 3 Watts without additional heat-sinks over the temperature range -40°C to +85°C.

Selection Guide

Part Number DIP24 Miniature	Input Voltage (VDC)	Output Voltage (VDC)	Output Current (mA)	Efficiency %	Max Capacitive Load ⁽¹⁾
RW-0505D	4.5 – 9	±5	±300	71	±2200µF
RW-0509D	4.5 – 9	±9	±167	73	±1000µF
RW-0512D	4.5 – 9	±12	±125	74	±1000µF
RW-0515D	4.5 – 9	±15	±100	75	±1000µF
RW-1205D	9 – 18	±5	±300	76	±2200µF
RW-1209D	9 – 18	±9	±167	80	±1000µF
RW-1212D	9 – 18	±12	±125	83	±1000µF
RW-1215D	9 – 18	±15	±100	83	±1000µF
RW-2405D	18 – 36	±5	±300	78	±2200µF
RW-2409D	18 – 36	±9	±167	81	±1000µF
RW-2412D	18 – 36	±12	±125	85	±1000µF
RW-2415D	18 – 36	±15	±100	85	±1000µF
RW-4805D	36 – 72	±5	±300	78	±2200µF
RW-4809D	36 – 72	±9	±167	82	±1000µF
RW-4812D	36 – 72	±12	±125	84	±1000µF
RW-4815D	36 – 72	±15	±100	84	±1000µF

Specifications (Core Operating Area)

Input Voltage Range	2:1
Output Voltage Accuracy	±1% typ. / ±2% max.
Line Voltage Regulation	0.1% typ. / 0.2% max.
Load Voltage Regulation (10% to 100% full load)	0.2% typ. / 0.5% max.
Minimum Load	10% ⁽²⁾
Output Ripple and Noise (20MHz limited)	50mVp-p max.
Operating Frequency	100kHz min. / 150kHz typ.
Efficiency at Full Load	See above
No Load Power Consumption	250mW max.
Isolation Voltage	(tested for 1 second) 3000VDC (rated for 1 minute*) 1500VAC / 60Hz
Isolation Capacitance	20pF min. / 40pF typ. / 60pF max.
Isolation Resistance	1 GΩ min.
Short Circuit Protection	Continuous
Operating Temperature Range (free air convection)	-40°C to +85°C (see Graph)

continued on next page

ECONOLINE

DC/DC-Converter

with 3 year Warranty

RECOM

3 Watt

DIP24

Low Profile Regulated Dual Output



EN-60950-1 Certified
EN-60601-1 Certified

RW-D

Derating-Graph (Ambient Temperature)

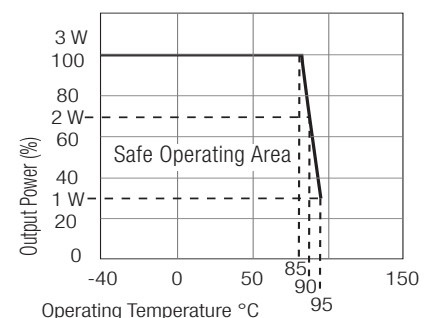

*Any data referred to in this datasheet are of indicative nature and based on our practical experience only. For further details, please refer to our Application Notes.

Refer to Application Notes

Specifications (Core Operating Area)

Storage Temperature Range	-55°C to +125°C		
Case Material	Non-Conductive Black Plastic		
Potting Material	Epoxy (UL94V-0)		
Relative Humidity	95% RH		
Package Weight	7.7g		
Packing Quantity	15pcs per Tube		
MTBF (+25°C)	} Detailed Information see Application Notes chapter "MTBF"	using MIL-HDBK 217F	1636 x 10 ³ hours
(+85°C)		using MIL-HDBK 217F	303 x 10 ³ hours

Certifications

EN General Safety	Report: SPCLVD1212007	EN60950-1:2006 + A11:2009+A1:2010+A12:2011
EN Medical Safety	Report: MDD1205098-3 + RM1205098-3	IEC/EN 60601-1 3rd Edition Medical Report + ISO14971 Risk Assessment

Notes

- Note 1: Maximum capacitive load is defined as the capacitive load that will allow start up in under 1 second without damage to the converter
- Note 2: The RW-D series require a minimum of 10% loading on the output to maintain specified regulation. Operating under un-load condition will not damage these devices, however they may not meet all listed specifications.

Typical Performance

RW-xx15D

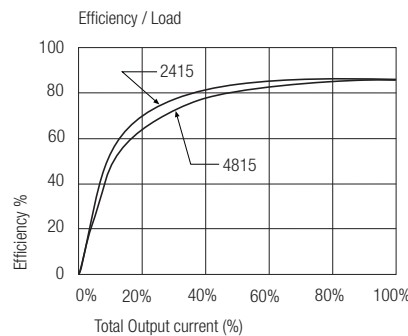

RW-D

Package Style and Pinning (mm)

24 PIN DIP Miniature Package Style

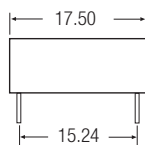
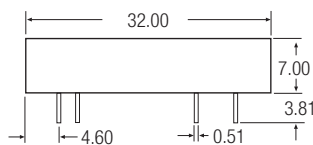

Recommended Footprint Details

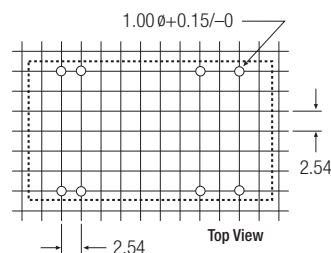
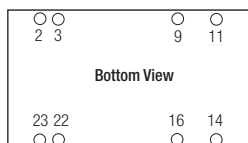

Pin Connections

Pin	Dual
2 & 3	-Vin
9 & 16	Com
11	-Vout
14	+Vout
22 & 23	+Vin
NC	No Connection

XX.X ± 0.5 mm
XX.XX ± 0.25 mm

The product information and specifications are subject to change without prior notice. All products are designed for non-safety critical commercial and industrial applications. The Buyer agrees to implement safeguards that anticipate the consequences of any failures that might cause harm, loss of life and/or damage property.

Features

Regulated Converters

- Low Cost 3W converter in DIP24 Package
- 1kVDC Isolation
- Regulated Output
- Continuous Short Circuit Protection
- Internal SMD design
- 3 Pinout Options, 3 Case Styles.
- Efficiency to 75%

Description

The REC3-SR/DR series is a low cost converter containing a built in linear regulator to give a regulated, load independent constant voltage output. The converter is designed to run from a regulated supply and is typically used to provide an isolated output or to generate dual rails from a single rail supply. The converters can deliver 140% rated power for short periods of time to cope with applications with large capacitive loads or high start up currents.

Selection Guide

Part Number DIP24 (SMD)	Input Voltage (VDC)	Output Voltage (VDC)	Output Current (mA)	Max Capacitive Load ⁽¹⁾
REC3-xx05SR/H1	5, 12, 24	5	600	4700µF
REC3-xx12SR/H1	5, 12, 24	12	250	2200µF
REC3-xx15SR/H1	5, 12, 24	15	200	2200µF
REC3-xx05DR/H1	5, 12, 24	±5	±300	±2200µF
REC3-xx12DR/H1	5, 12, 24	±12	±125	±1000µF
REC3-xx15DR/H1	5, 12, 24	±15	±100	±1000µF

xx = Input Voltage. Other input and output voltage combinations available on request.

* add suffix "/SMD" for SMD package, e.g. REC3-0505SR/H1/SMD

* add suffix "/M" for Metal Case, e.g. REC3-0505SR/H1/M

* add suffix "-R" for Tape and Reel packaging, e.g. REC3-0505SR/H1/SMD-R

Specifications (measured at T_A = 25°C, nominal input voltage, full load and after warm-up)

Input Voltage Range	5V 12V 24V	4.5V - 5.75V 10.2V - 13.8V 20.4V - 27.6V
Output Voltage Accuracy		±3% typ.
Line Voltage Regulation		±0.5% max
Load Voltage Regulation (10% to 100% full load)		±1% max.
Minimum Load		10% ⁽²⁾
Output Ripple and Noise (at 20MHz BW)		100mVp-p max.
Operating Frequency		75kHz min.
Efficiency at Full Load		65% min.
No Load Power Consumption		300mW max.
Isolation Voltage	(tested for 1 second) (rated for 1 minute**)	1000VDC 500VAC / 60Hz
Isolation Capacitance		30pF typ.
Isolation Resistance		1 GΩ min.
Short Circuit Protection		Continuous
Operating Temperature Range (free air convection)		-40°C to +80°C (see Graph)
Storage Temperature Range		-55°C to +125°C
Relative Humidity		95% RH
Thermal Impedance	Natural convection	20°C/W for plastic case 12°C/W for metal case
Package Weight		12g
Packing Quantity		15 pcs per Tube 100 pcs per Reel
MTBF (+25°C)	} Detailed Information see Application Notes chapter "MTBF"	using MIL-HDBK 217F
(+80°C)		using MIL-HDBK 217F

continued on next page

ECONOLINE

DC/DC-Converter

with 3 year Warranty

RECOM

3 Watt DIP24 & SMD Single & Dual Output



EN-60950-1 Certified

REC3-S_DR

Derating-Graph (Ambient Temperature)

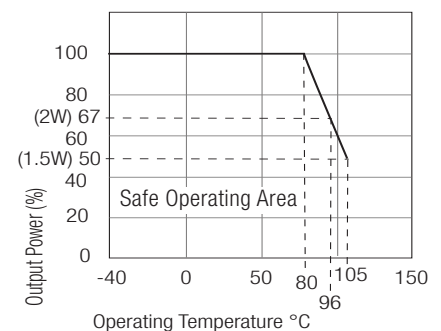

**Any data referred to in this datasheet are of indicative nature and based on our practical experience only. For further details, please refer to our Application Notes.

Refer to Application Notes

Specifications (measured at $T_A = 25^\circ\text{C}$, nominal input voltage, full load and after warm-up)

Certifications
EN General Safety

Report: SPCLVD1212007

EN60950-1:2006 + A11:2009+A1:2010+A12:2011

Notes

- Note 1: Maximum capacitive load is defined as the capacitive load that will allow start up in under 1 second without damage to the converter
- Note 2: The REC3-R series require a minimum of 10% loading on the output to maintain specified regulation. Operating under un-load condition will not damage these devices, however they may not meet all listed specifications.

Package Style and Pinning (mm)

24 PIN DIP Package

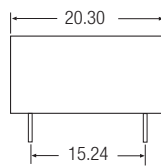
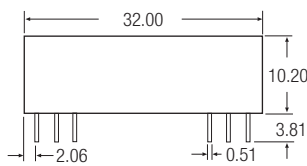

Recommended Footprint Details

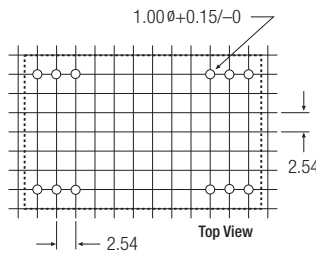
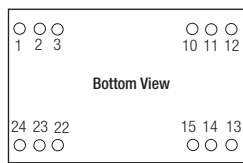

Pin Connections

Pin #	Single	Dual
1	+Vin	+Vin
2	No Pin	-Vout
3	No Pin	Com
10	-Vout	Com
11	+Vout	+Vout
12	-Vin	-Vin
13	-Vin	-Vin
14	+Vout	+Vout
15	-Vout	Com
22	No Pin	Com
23	No Pin	-Vout
24	+Vin	+Vin

NC = No Connection

XX.X ± 0.5 mm
XX.XX ± 0.25 mm

24 PIN DIP SMD Package

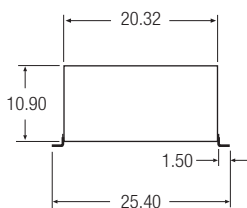
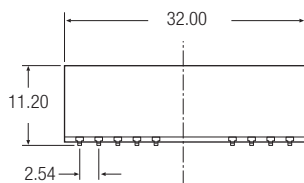

Recommended Footprint Details

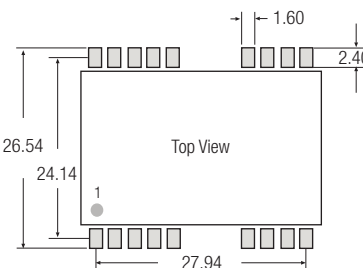
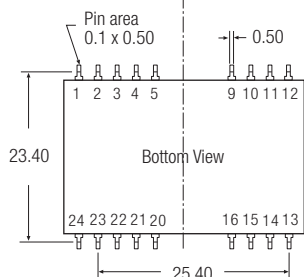

Pin Connections

Pin #	Single	Dual
1	+Vin	+Vin
2	NC	-Vout
3	NC	Com
4	NC	NC
5	NC	NC
9	NC	NC
10	-Vout	Com
11	+Vout	+Vout
12	-Vin	-Vin
13	-Vin	-Vin
14	+Vout	+Vout
15	-Vout	Com
16	NC	NC
20	NC	NC
21	NC	NC
22	NC	Com
23	NC	-Vout
24	+Vin	+Vin

XX.X ± 0.5 mm
XX.XX ± 0.25 mm

SMD pin connections follow standard package pinning.

All unused pins are NC (No Connection).

The product information and specifications are subject to change without prior notice. All products are designed for non-safety critical commercial and industrial applications. The Buyer agrees to implement safeguards that anticipate the consequences of any failures that might cause harm, loss of life and/or damage property.

Features

Regulated Converters

- 2kV, 4kVDC & 6kVDC Isolation
- Industry Standard 3W DIP24 Package
- Feedback Regulated Output
- Continuous Short Circuit Protection
- Wide Input 2:1 & 4:1
- Medical Approvals (4kV/6kV Versions)
- EN and UL Certificates
- 3 Pinout Options, 3 Case Styles
- Control Pin Option
- Efficiency to 86%

Description

Besides the standard isolation of 2kVDC, this series offers options of 4kVDC (= "/H4") or 6kVDC (= "/H6") making it suitable for medical applications and other sophisticated industrial applications. Packaging can be either DIP-24 plastic or 5-side-shielded DIP24 metal case (= option "/M") as well as SMD pinning (= option "/SMD"). For all the above variants, 2 industry-standard pinouts (= option "/A" or "/C") are available, and B pinning is available with 1.6kVDC isolation. Remote on/off control is possible with the /CTRL option (A pinning only). The converters can deliver 140% rated power for short periods of time to cope with applications with large capacitive loads or high start up currents.

Selection Guide

Part Number DIP24 (SMD)	Input Voltage (VDC)	Output Voltage (VDC)	Output Current (mA)	Efficiency (%)	Max Capacitive Load ⁽¹⁾
REC3-xx3.3SRW/H*	4.5 - 9, 9 - 18, 18 - 36, 36 - 72	3.3	900	66-76	4700µF
REC3-xx05SRW/H*	4.5 - 9, 9 - 18, 18 - 36, 36 - 72	5	600	71-79	4700µF
REC3-xx09SRW/H*	4.5 - 9, 9 - 18, 18 - 36, 36 - 72	9	330	74-83	3300µF
REC3-xx12SRW/H*	4.5 - 9, 9 - 18, 18 - 36, 36 - 72	12	250	75-85	2200µF
REC3-xx15SRW/H*	4.5 - 9, 9 - 18, 18 - 36, 36 - 72	15	200	75-86	2200µF
REC3-xx05DRW/H*	4.5 - 9, 9 - 18, 18 - 36, 36 - 72	±5	±300	74-83	±2200µF
REC3-xx12DRW/H*	4.5 - 9, 9 - 18, 18 - 36, 36 - 72	±12	±125	75-85	±1000µF
REC3-xx15DRW/H*	4.5 - 9, 9 - 18, 18 - 36, 36 - 72	±15	±100	75-86	±1000µF
REC3-xx3.3SRWZ/H*	9 - 36, 18 - 72	3.3	900	77-79	4700µF
REC3-xx05SRWZ/H*	9 - 36, 18 - 72	5	600	78-80	4700µF
REC3-xx09SRWZ/H*	9 - 36, 18 - 72	9	330	80-83	3300µF
REC3-xx12SRWZ/H*	9 - 36, 18 - 72	12	250	83-85	2200µF
REC3-xx15SRWZ/H*	9 - 36, 18 - 72	15	200	83-85	2200µF
REC3-xx05DRWZ/H*	9 - 36, 18 - 72	±5	±300	77-80	±2200µF
REC3-xx12DRWZ/H*	9 - 36, 18 - 72	±12	±125	83-85	±1000µF
REC3-xx15DRWZ/H*	9 - 36, 18 - 72	±15	±100	83-85	±1000µF

H* = H2, H4 or H6 for A or C pinning options with 2kVDC, 4kVDC or 6kVDC isolation.

H* = H for B pinning option with 1.6kVDC isolation only.

2:1 Input
(REC3-S/DRWH4/H6)
xx = 4.5-9Vin = 05
xx = 9-18Vin = 12
xx = 18-36Vin = 24
xx = 36-72Vin = 48

4:1 Input
(REC3-S/DRWZ(H4/H6))
xx = 9-36Vin = 24
xx = 18-72Vin = 48

- * add suffix "/A", "/AX2", "/B" or "/C" for pinning options, see next page and Isolation Restrictions.
- * add suffix "/M" for metal case.
- * add suffix "/SMD" for SMD package.
- * add suffix "/CTRL" for control pin option (A Pinning only)
- * add suffix -R for Tape and Reel packaging

Ordering Examples:

REC3-0512DRW/H2/A/CTRL = 2:1 input, 5V Vin, ±12V Vout, 2kVDC, pinout "A", plastic case, control pin
 REC3-4812SRWZ/H4/A/M = 4:1 input, 48V Vin, 12V Vout, 4kVDC, pinout "A", metal case, no control pin
 REC3-2412DRWZ/H/B = 4:1 input, 24V Vin, ±12V Vout, 1.6kVDC, pinout "B", plastic case, no control pin
 REC3-0505SRW/H6/C/SMD-R = 2:1 input, 5V Vin, 5V Vout, 6kVDC, SMD pinout "C", plastic case, no control pin, Tape and Reel packaging.

ECONOLINE

DC/DC-Converter

with 3 year Warranty

RECOM

3 Watt

DIP24 & SMD

Single & Dual

Output



E-358085

EN-60950-1 Certified
UL-60950-1 Certified
EN-60601-1 Certified

REC3-S_DRW

Isolation Restrictions

'B' Pinning is restricted to 1.6kV isolation due to the closeness of the input and output pins.

If the options "/M" for metal case and "/SMD" for SMD pinout are combined, the maximum allowed isolation voltage is 2kVDC because of the shorter distances between pins and the metal case.

DIP-24 through-hole case and SMD-plastic case are not affected and offer the full isolation barriers of 2kV through to 6kVDC.

Refer to Application Notes

Specifications (measured at $T_A = 25^\circ\text{C}$, nominal input voltage, full load and after warm-up)

Input Voltage Range			2:1 & 4:1
Output Voltage Accuracy			$\pm 2\%$ max.
Line Regulation (HL-LL)			$\pm 0.4\%$ max.
Load Regulation (for output load current change from 20% to 100%)			$\pm 0.6\%$ max.
Minimum Load			10% ⁽²⁾
Output Ripple and Noise (0,1 μF capacitor on output, 20MHz BW)			50mVp-p max.
Switching Frequency at Full Load	2:1 Input types	90kHz min. / 150kHz max.	
and nominal Input Voltage	4:1 Input types	120kHz min. / 180kHz max.	
Input Filter			Pi Network
Efficiency at Full Load			see above
No Load Power Consumption			300mW max.
Isolation Voltage	H2-Suffix	(tested for 1 second) (rated for 1 minute**)	2000VDC 1000VAC / 60Hz
Isolation Voltage	H4-Suffix	(tested for 1 second) (rated for 1 minute**)	4000VDC 2000VAC / 60Hz
Isolation Voltage	H6-Suffix	(tested for 1 second) (rated for 1 minute**)	6000VDC 3000VAC / 60Hz
Isolation Capacitance	2:1 Input types	20pF min. / 60pF max.	
	4:1 Input types	40pF min. / 80pF max.	
Isolation Resistance			1 G Ω min.
Short Circuit Protection (Max temp. = 60°C during short circuit conditions)			Continuous, Auto Restart
Operating Temperature Range (free air convection)	5V input types	-40°C to +80°C (see Graph)	
	others	-40°C to +85°C (see Graph)	
Storage Temperature Range			-55°C to +125°C
Relative Humidity			95% RH
Case Material			Non-Conductive Plastic or Metal
Thermal Impedance	Natural convection	20°C/W for plastic case 12°C/W for metal case	
Package Weight			13g
Packing Quantity			15 pcs per Tube 100 pcs per Reel
MTBF (+25°C)	} Detailed Information see Application Notes chapter "MTBF"	using MIL-HDBK 217F	1043 x 10 ³ hours
(+85°C)		using MIL-HDBK 217F	186 x 10 ³ hours
Certifications	UL General Safety Report: E358085	UL 60950-1 1st Ed. C22.2 No. 60950-1-03	
	EN General Safety Report: SPCLVD1212007 EN60950-1:2006 + A1:2010+A12:2011		
	EN Medical Safety Report: MDD1205098-3 + RM1205098-3 IEC/EN 60601-1 3rd Ed.		
	Medical Report + ISO14971 Risk Assessment		

Derating-Graph (Ambient Temperature)

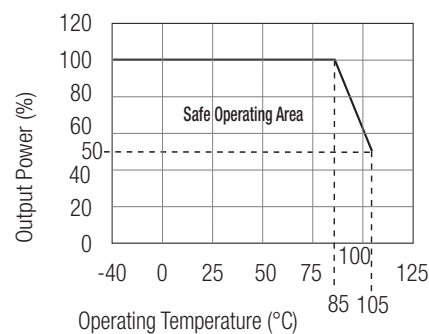
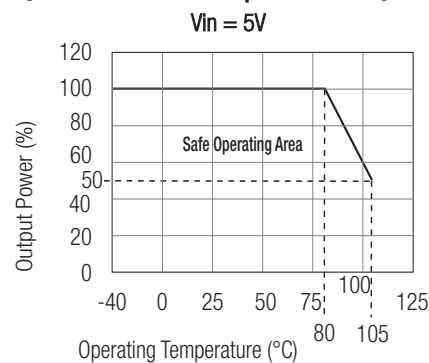

**Any data referred to in this datasheet are of indicative nature and based on our practical experience only. For further details, please refer to our Application Notes.

Notes

- Note 1: Maximum capacitive load is defined as the capacitive load that will allow start up in under 1 second without damage to the converter
- Note 2: The REC3-RW series require a minimum of 10% loading on the output to maintain specified regulation. Operating under un-load condition will not damage these devices, however they may not meet all listed specifications.

Typical Characteristics

Single 2:1 Input

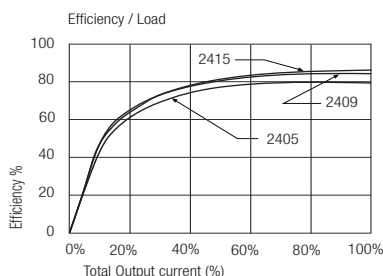

Single 2:1 Input

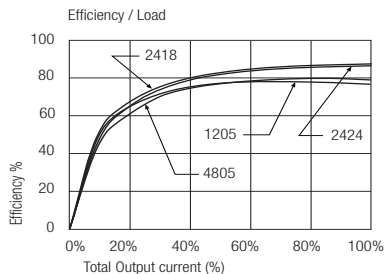

Dual 2:1 Input

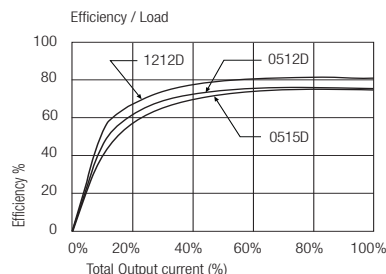

Typical Characteristics - Continued

Single 4:1 Input

Single 4:1 Input

Dual 4:1 Input

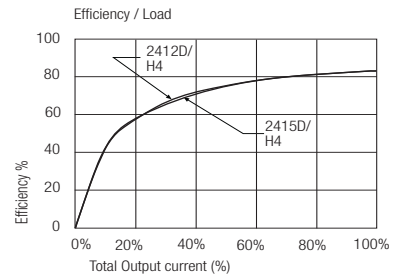
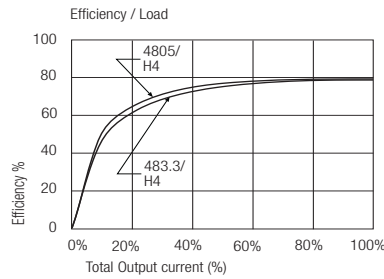
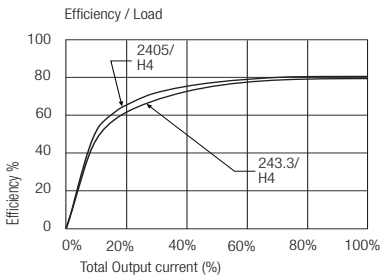

Package Style and Pinning (mm) DIP 24 , Wide Input 2:1 & 4:1

"A" Pinning
/H2, /H4 & /H6

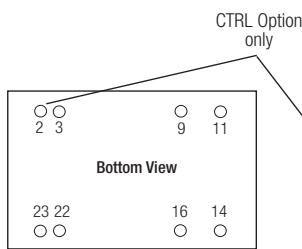
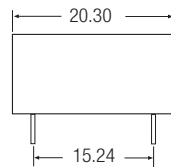
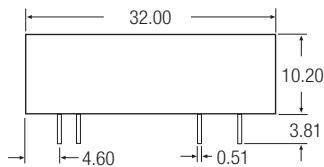

Recommended Footprint Details

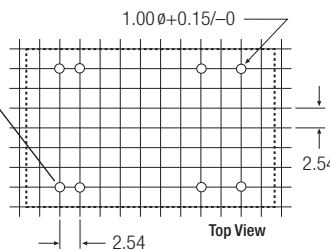

Pin Connections

Pin #	Single	Single/X2	Dual
1 (option)	CTRL	CTRL	CTRL
2	-Vin	-Vin	-Vin
3	-Vin	-Vin	-Vin
9	NC	No Pin	Com
11	NC	NC	-Vout
14	+Vout	+Vout	+Vout
16	-Vout	-Vout	Com
22	+Vin	+Vin	+Vin
23	+Vin	+Vin	+Vin

NC = No Connection
XX.X ± 0.5 mm
XX.XX ± 0.25 mm

CTRL Option

ON = Open or $0V < V_{ctrl} < 1.2V$
OFF = $2.2V < V_{ctrl} < 12V$

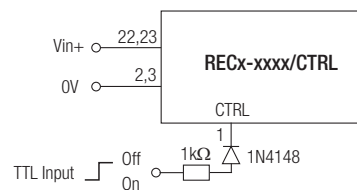

"C" Pinning
/H2, /H4 & /H6

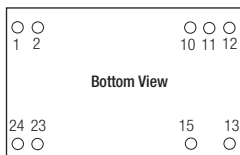
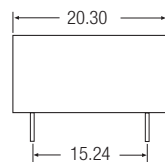
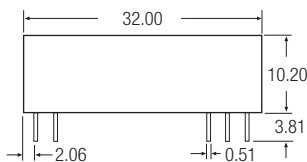

Recommended Footprint Details

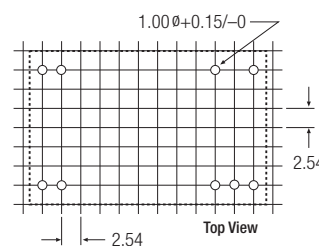

Pin Connections

Pin #	Single	Dual
1	+Vin	+Vin
2	+Vin	+Vin
10	NC	Com
11	NC	Com
12	-Vout	NC
13	+Vout	-Vout
15	NC	+Vout
23	-Vin	-Vin
24	-Vin	-Vin

NC = No Connection

XX.X ± 0.5 mm
XX.XX ± 0.25 mm

Package Style and Pinning (mm) DIP 24 , Wide Input 2:1 & 4:1

"B" Pinning /H (1.6kV Only)

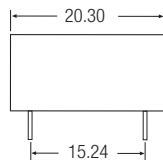
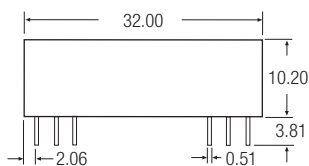

Recommended Footprint Details

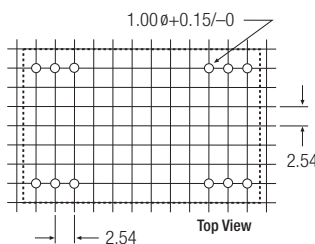
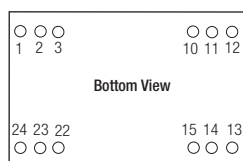

Pin Connections

Pin #	Single	Dual
1	+Vin	+Vin
2	No Pin	-Vout
3	No Pin	Com
10	-Vout	Com
11	+Vout	+Vout
12	-Vin	-Vin
13	-Vin	-Vin
14	+Vout	+Vout
15	-Vout	Com
22	No Pin	Com
23	No Pin	-Vout
24	+Vin	+Vin

NC = No Connection

XX.X ± 0.5 mm

XX.XX ± 0.25 mm

SMD Pinning

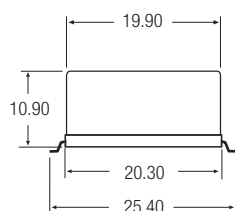
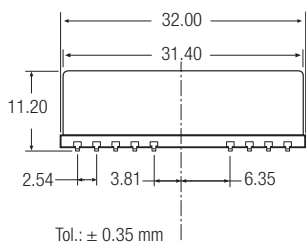

Recommended Footprint Details

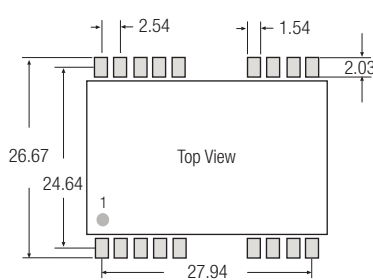
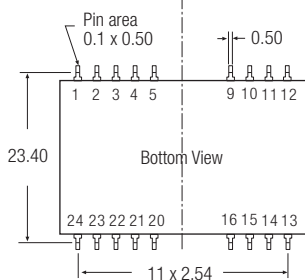

SMD pin connections follow standard package A (/A/SMD), B (/B/SMD) or C (/C/SMD) pinning.

All unused pins are NC (No Connection). See Below for detailed pinout lists

for all packages incl.SMD case the length of plastic case is 31,8 mm, length of metal case 32.0 mm

/A/SMD Pinning

/B/SMD Pinning

/C/SMD Pinning

Pin Connections			Pin Connections			Pin Connections			Pin Connections			Pin Connections		
Pin #	Single	Dual	Pin #	Single	Dual	Pin #	Single	Dual	Pin #	Single	Dual	Pin #	Single	Dual
1 (Option)	CTRL	CTRL	13	NC	NC	1	+Vin	+Vin	13	-Vin	-Vin	1	+Vin	+Vin
2	-Vin	-Vin	14	+Vout	+Vout	2	NC	-Vout	14	+Vout	+Vout	2	+Vin	+Vin
3	-Vin	-Vin	15	NC	NC	3	NC	Com	15	-Vout	Com	3	NC	NC
4	NC	NC	16	-Vout	Com	4	NC	NC	16	NC	NC	4	NC	NC
5	NC	NC	20	NC	NC	5	NC	NC	20	NC	NC	5	NC	NC
9	NC	Com	21	NC	NC	9	NC	NC	21	NC	NC	9	NC	NC
10	NC	NC	22	+Vin	+Vin	10	-Vout	Com	22	NC	Com	10	NC	Com
11	NC	-Vout	23	+Vin	+Vin	11	+Vout	+Vout	23	NC	-Vout	11	NC	Com
12	NC	NC	24	NC	NC	12	-Vin	-Vin	24	+Vin	+Vin	12	-Vout	NC

Features

Regulated Converters

- 8kVDC & 10kVDC Reinforced Isolation
- Industry Standard DIP24 Package
- 3.5W Regulated Output
- Continuous Short Circuit Protection
- Wide Input 2:1
- Medical Approved
- EN, CSA and CB Certificates
- 2 Pinout Options
- Control Pin Option
- Efficiency to 86%

Description

The REC3.5 series uses a reinforced isolation transformer to offer exceptionally high isolation of 8kVDC (4kVAC/1 minute) or 10kVDC (5kVAC/1minute) making it suitable for HT monitoring circuits, mains power meters, IGBT isolated power supplies and other sophisticated industrial and medical applications. The isolation capacitance of only 20pF makes them also suitable for low leakage applications. The isolation transformer is recognised by CSA as reinforced isolated with a minimum internal clearance of 2.4mm and a minimum internal creepage clearance of 4.6mm. The REC3.5 is available in two industry-standard pinouts (= "/A" or "/C"). Remote on/off control is possible with the /CTRL option (A pinning only) and an optional undervoltage lockout function is also available (= "/X1"). The converters can deliver 140% rated power for short periods of time to cope with applications with large capacitive loads or high start up currents.

Selection Guide

Part Number DIP24	Input Voltage (VDC)	Output Voltage (VDC)	Output Current (mA)	Efficiency (%)	Max Capacitive Load ⁽¹⁾
REC3.5-xx05SRW/R*	9 - 18, 18 - 36, 36 - 75 4.5 - 9	5	700	80, 81, 82 77	4700µF
REC3.5-xx09SRW/R*	9 - 18, 18 - 36, 36 - 75 4.5 - 9	9	388	81, 82, 83 80	3300µF
REC3.5-xx12SRW/R*	9 - 18, 18 - 36, 36 - 75 4.5 - 9	12	290	82, 83, 84 82	2200µF
REC3.5-xx15SRW/R*	9 - 18, 18 - 36, 36 - 75 4.5 - 9	15	233	84, 85, 86 83	2200µF
REC3.5-xx24SRW/R*	9 - 18, 18 - 36, 36 - 75 4.5 - 9	24	145	83, 84, 85 82	1000µF
REC3.5-xx05DRW/R*	9 - 18, 18 - 36, 36 - 75 4.5 - 9	±5	±350	80, 81, 82 77	±2200µF
REC3.5-xx09DRW/R*	9 - 18, 18 - 36, 36 - 75 4.5 - 9	±9	±194	81, 82, 83 80	±1600µF
REC3.5-xx12DRW/R*	9 - 18, 18 - 36, 36 - 75 4.5 - 9	±12	±145	81, 82, 83 82	±1000µF
REC3.5-xx15DRW/R*	9 - 18, 18 - 36, 36 - 75 4.5 - 9	±15	±117	82, 83, 84 80	±1000µF

R* = R8 or R10 for 8kVDC or 10kVDC isolation.

Note 1: Maximum capacitive load is defined as the capacitive load that will allow start up in under 1 second without damage to the converter.

* add suffix "/A" or "/C" for pinning options, see next page for details.

* add suffix "/CTRL" for control pin option (A Pinning only)

* add suffix "/X1" for Undervoltage Lockout

2:1 Input
(REC3.5-S_DRW/R8(R10))
xx = 4.5-9Vin = 05
xx = 9-18Vin = 12
xx = 18-36Vin = 24
xx = 36-75Vin = 48

Ordering Examples:

REC3.5-0512DRW/R8/A/CTRL= 5V Vin, ±12V Vout, 8kVDC isolation, pinout "A", control pin

REC3.5-4805SRW/R10/A = 48V Vin, 5V Vout, 10kVDC isolation, pinout "A"

REC3.5-1212DRW/R8/C/X1 = 12V Vin, ±12V Vout, 8kVDC isolation, pinout "C", UVL

REC3.5-0505SRW/R10/A/CTRL/X1 = 5V Vin, 5V Vout, 10kVDC isolation, pinout "A", control pin, UVL

ECONOLINE

DC/DC-Converter

with 3 year Warranty

RECOM

3.5 Watt DIP24 Reinforced Single & Dual Output



C22.2-No. 60950 Certified
C22.2-601.1 Certified
UL-60601.1 Certified

REC3.5/R

Derating-Graph (Ambient Temperature)

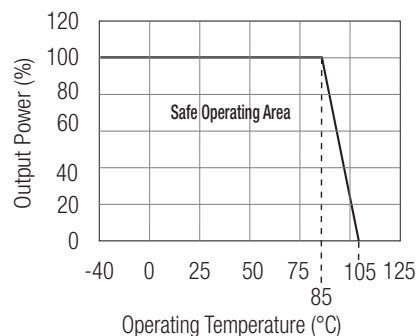

Refer to Application Notes

Specifications (measured at $T_A = 25^\circ\text{C}$, nominal input voltage, full load and after warm-up)

Input Voltage Range			2:1
Output Voltage Accuracy			$\pm 2\%$ max.
Line Regulation	(HL-LL)		$\pm 0.3\%$ max.
Load Regulation	(for output load current change from 20% to 100%)		$\pm 0.6\%$ max.
Input Surge	(1 minute)	5V types	16V max.
		12V types	25V max.
		24V types	50V max.
		48V types	100V max.
Undervoltage Lockout	(/X1 Versions)	5V types	3.5V typ. ($\pm 20\%$)
		12V types	7V typ. ($\pm 20\%$)
		24V types	15V typ. ($\pm 10\%$)
		48V types	32V typ. ($\pm 10\%$)
Output Ripple and Noise	(0,1 μF capacitor on output, 20MHz BW limited)		150mVp-p max.
Transient Response	(25% step change)		1ms typ.
Switching Frequency	(Full load and nominal input voltage)		150kHz min. / 500kHz max.
Input Filter			Pi Network
Capacitors	All types		MLCC capacitors only
Minimum Load	(Operation under no load will not damage the converter, but it may not meet all specifications)		20% Full Load
No Load Power Consumption			400mW max.
Isolation Voltage	R8-Suffix	(tested for 1 second) (rated for 1 minute**)	8000VDC 4000VAC / 60Hz
Isolation Voltage	R10-Suffix	(tested for 1 second) (rated for 1 minute**)	10000VDC. 5000VAC / 60Hz
Isolation Capacitance			20pF typ.
Isolation Resistance			10 $\text{G}\Omega$ min.
Short Circuit Protection		(Max operating temp. = 60°C during short circuit conditions)	Continuous, Auto Restart
Operating Temperature Range		(free air convection)	-40°C to $+85^\circ\text{C}$ (see Graph)
Case Temperature			105°C max.
Storage Temperature Range			-55°C to $+125^\circ\text{C}$
Relative Humidity			95% RH
Case Material			Non-Conductive Plastic
Potting Material			Silicone
Thermal Impedance		Natural convection	$20^\circ\text{C}/\text{W}$
Package Weight			14g
Packing Quantity			15 pcs per Tube
MTBF ($+25^\circ\text{C}$)	} Detailed Information see Application Notes chapter "MTBF"	using MIL-HDBK 217F	1206 x 10^3 hours
($+75^\circ\text{C}$)		using MIL-HDBK 217F	392x 10^3 hours
EMC	Conducted Emissions	EN55022	Class A
(with 470 μF / $0.1\mu\text{F}$ capacitors across input)	Radiated Emissions	EN55022	Class A
Reinforced Isolation	Transformer Creepage	/R8 and /R10 Types	4.6 mm min.
	Transformer Clearance	/R8 and /R10 Types	2.4 mm min.
	PCB Creepage & Clearance	/R8 and /R10 Types	6.0 mm min.
	Optocoupler Creepage	/R8 and /R10 Types	6.0 mm min.
External Creepage and Clearance	Plastic Case	Input <-> Output pins	14.2 mm min.
Certifications	EN Medical Safety	Report: MDD1207051 + RM1207051 Medical Report + ISO14971 Risk Assessment	EN 60601-1 3rd Edition
	IEC Medical Safety	CB Report: CA-10168-A1-UL	IEC 60601-1 3rd Edition
	CSA Medical Safety	Report: 2202478	C22.2 601-1 2nd Ed.
	UL Medical Safety	E314885-A4	UL 60601-1 3rd Edition
	General Safety	Report: 2219431	C22.2 No. 60950-1-03
	UL 60950-1 1st Ed.	Recognised as Reinforced Isolation	Supplement to Report: 2219431

**Any data referred to in this datasheet are of indicative nature and based on our practical experience only. For further details, please refer to our Application Notes.

Typical Characteristics - Continued

Efficiency vs Load

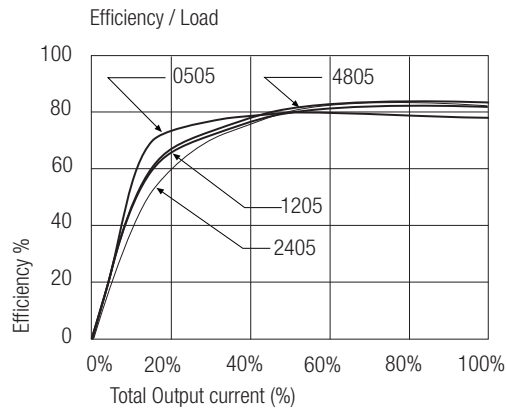

REC3.5-xx05SRW/R*
REC3.5-xx05DRW/R*

Efficiency vs Vin

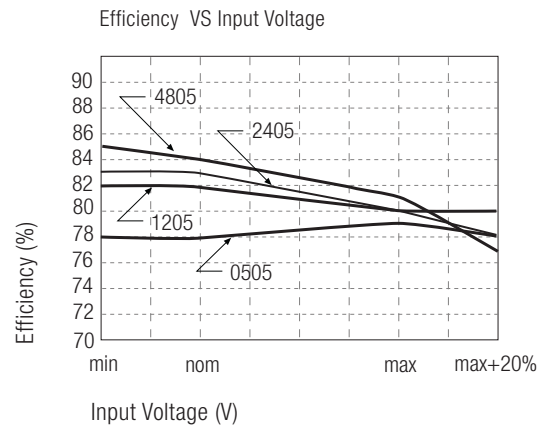

REC3.5-xx12SRW/R*

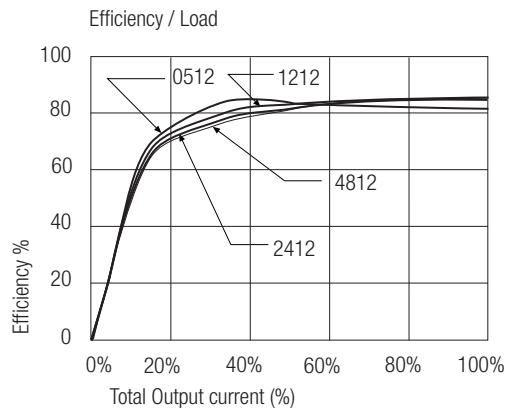

Efficiency VS Input Voltage

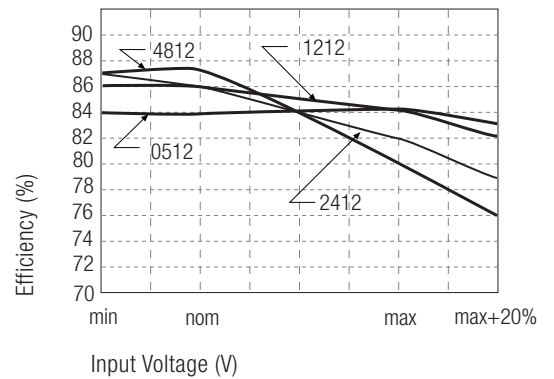

REC3.5/R

REC3.5-xx24SRW/R*
REC3.5-xx12DRW/R*

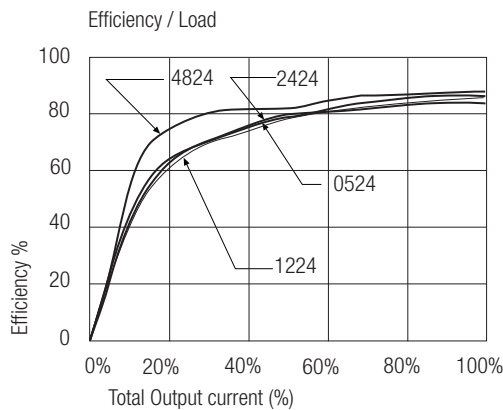

Efficiency VS Input Voltage

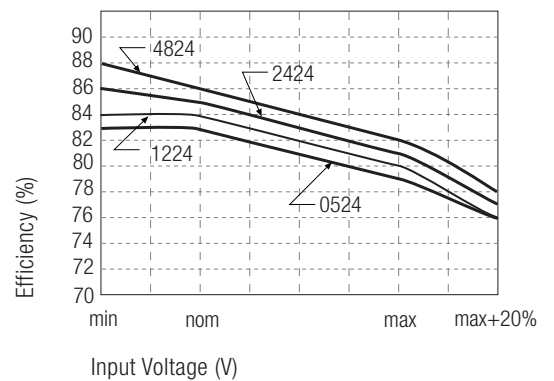

"A" Pinning /R8 & /R10

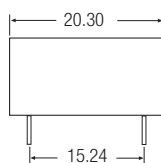
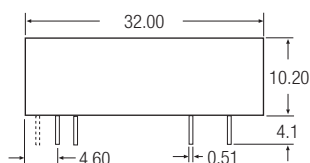

Recommended Footprint Details

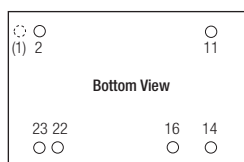

CRTL Version only

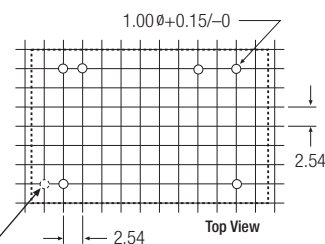

Pin Connections

Pin #	Single	Dual
1 (option)	CTRL	CTRL
2	-Vin	-Vin
11	NC	-Vout
14	+Vout	+Vout
16	-Vout	Com
22	+Vin	+Vin
23	+Vin	+Vin

NC = No Connection

XX.X ± 0.5 mm
XX.XX ± 0.25 mm

CTRL Option

ON = Open or $0V < V_{ctrl} < 1.2V$
OFF = $2.2V < V_{ctrl} < 12V$

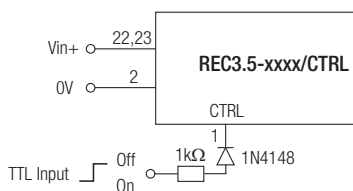

"C" Pinning /R8 & /R10

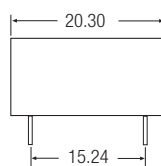
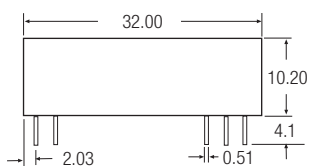

Recommended Footprint Details

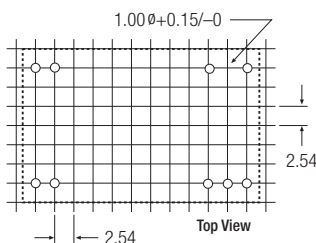
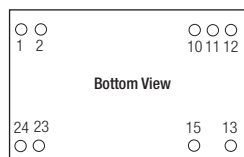

Pin Connections

Pin #	Single	Dual
1	+Vin	+Vin
2	+Vin	+Vin
10	NC	Com
11	NC	Com
12	-Vout	NC
13	+Vout	-Vout
15	NC	+Vout
23	-Vin	-Vin
24	-Vin	-Vin

NC = No Connection

XX.X ± 0.5 mm
XX.XX ± 0.25 mm

Features

Regulated Converters

- High 4kVDC & 6kVDC Isolation
- 5W DIP24 Industry Standard Package
- Feedback Regulated Output
- Continuous Short Circuit Protection
- Wide Inputs 2:1 & 4:1
- Approved for Medical Applications
- UL and EN Safety Approvals
- 2 Pinout Options, 3 Case Styles
- Efficiency to 86 %

Description

This series offers standard isolation of 2kVDC with 4kVDC or 6kVDC options making it ideal for both industrial, medical and other sophisticated high end applications. Packaging can be either DIP-24 non-conductive plastic or 5-side-shielded DIP24 metal case (= option "/M") as well as DIP24-SMD case (= option "/SMD"). For all the above variants, 2 industry-standard pinouts (= option "/A" or "/C") are available. "B" pinning is also available with "/H" isolation of 1.6kVDC. Remote on/off control is possible with the /CTRL option ("A" pinning only). The converters can deliver 140% rated power for short periods of time to cope with applications with large capacitive loads or high start up currents.

Selection Guide

Part Number DIP24 (SMD)	Input Voltage (VDC)	Output Voltage (VDC)	Output Current (mA)	Efficiency (%)	Max Capacitive Load ⁽¹⁾
REC5-xx3.3SRW/H*	9 - 18, 18 - 36, 36 - 72	3.3	1000	75-77	6800µF
REC5-xx05SRW/H*	9 - 18, 18 - 36, 36 - 72	5	1000	79-81	6800µF
	4.5 - 9V			72	
REC5-xx09SRW/H*	9 - 18, 18 - 36, 36 - 72	9	556	82-83	6800µF
	4.5 - 9V			73	
REC5-xx12SRW/H*	9 - 18, 18 - 36, 36 - 72	12	420	84-85	6800µF
	4.5 - 9V			74	
REC5-xx15SRW/H*	9 - 18, 18 - 36, 36 - 72	15	340	85-86	6800µF
	4.5 - 9V			75	
REC5-xx05DRW/H*	9 - 18, 18 - 36, 36 - 72	±5	±500	79-81	±2200µF
	4.5 - 9V			72	
REC5-xx09DRW/H*	9 - 18, 18 - 36, 36 - 72	±9	±278	82-84	±2200µF
	4.5 - 9V			74	
REC5-xx12DRW/H*	9 - 18, 18 - 36, 36 - 72	±12	±210	84-85	±2200µF
	4.5 - 9V			75	
REC5-xx15DRW/H*	9 - 18, 18 - 36, 36 - 72	±15	±170	85-86	±2200µF
	4.5 - 9V			75	
REC5-xx3.3SRWZ/H*	9 - 36**, 18 - 72	3.3	1000	75-76	6800µF
REC5-xx05SRWZ /H*	9 - 36**, 18 - 72	5	1000	81-82	6800µF
REC5-xx09SRWZ/H*	9 - 36, 18 - 72	9	556	82-83	6800µF
REC5-xx12SRWZ /H*	9 - 36, 18 - 72	12	420	83-84	6800µF
REC5-xx15SRWZ/H*	9 - 36, 18 - 72	15	340	84-85	6800µF
REC5-xx05DRWZ/H*	9 - 36**, 18 - 72	±5	±500	81-82	±2200µF
REC5-xx09DRWZ/H*	9 - 36, 18 - 72	±9	±278	82-84	±2200µF
REC5-xx12DRWZ /H*	9 - 36, 18 - 72	±12	±210	82-83	±2200µF
REC5-xx15DRWZ /H*	9 - 36, 18 - 72	±15	±170	84-85	±2200µF

H* = H2, H4 or H6 for A or C pinning options with 2kVDC, 4kVDC or 6kVDC isolation.

H* = H for B pinning option with 1.6kVDC isolation only. ** Derate to 900mA (±450mA) max. at Vin=9V

* add suffix "/A", "/A/X2", "/B" or "/C" for pinning options, see next page and Isolation Restrictions.

* add suffix "/M" for metal case.

* add suffix "/SMD" for SMD package.

* add suffix "/CTRL" for control pin option (A Pinning only)

* add suffix -R for Tape and Reel packaging

2:1 Input

(REC5-S/DRW)

xx = 4.5-9Vin = 05

xx = 9-18Vin = 12

xx = 18-36Vin = 24

xx = 36-72Vin = 48

4:1 Input

(REC5-S/DRWZ)

xx = 9-36Vin = 24

xx = 18-72Vin = 48

ECONOLINE

DC/DC-Converter

with 3 year Warranty

RECOM

5 Watt DIP24 & SMD Single & Dual Output



RoHS
2011/65/EU
6/6

EN60950-1
E358085

EN-60950-1 Certified

UL-60950-1 Certified

EN-60601-1 Certified

REC 5

Derating-Graph

(Ambient Temperature)

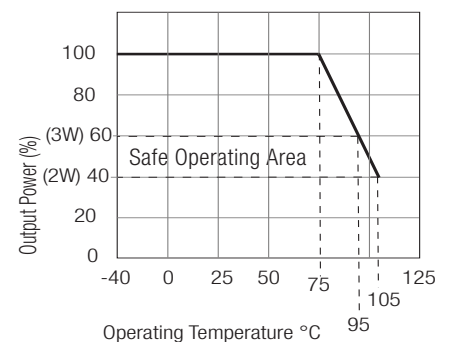

Refer to Application Notes

Specifications (measured at $T_A = 25^\circ\text{C}$, nominal input voltage, full load and after warm-up)

Input Voltage Range			2:1 & 4:1
Output Voltage Accuracy			$\pm 2\%$ max.
Line Regulation (HL-LL)			$\pm 0.3\%$ max.
Load Regulation (for output load current change from 20% to 100%)			$\pm 0.6\%$ max.
Minimum Load			10% ⁽²⁾
Output Ripple and Noise (0,1 μF capacitor on output, 20MHz BW)			50mVp-p max.
Operating Frequency at Full Load	2:1 input		120kHz typ.
(at nominal input voltage)	4:1 input		200kHz typ.
Input Filter			Pi Network
Efficiency at Full Load			see above
No Load Power Consumption			300mW max.
Isolation Voltage	H2-Suffix	(tested for 1 second) (rated for 1 minute**)	2000VDC 1000VAC / 60Hz
Isolation Voltage	H4-Suffix	(tested for 1 second) (rated for 1 minute**)	4000VDC 2000VAC / 60Hz
Isolation Voltage	H6-Suffix	(tested for 1 second) (rated for 1 minute**)	6000VDC 3000VAC / 60Hz
Isolation Capacitance			60pF typ.
Isolation Resistance			1 G Ω min.
Short Circuit Protection (Max temp. = 50°C during short circuit conditions)			Continuous, Auto Restart
Operating Temperature (free air convection)			-40°C to +75°C (see Graph)
Storage Temperature Range			-55°C to +125°C
Relative Humidity			95% RH
Case Material			Non-Conductive Plastic or Metal
Thermal Impedance	Natural convection		20°C/W for plastic case 12°C/W for metal case
Package Weight			13g
Packing Quantity			15 pcs per Tube 100 pcs per Reel
MTBF (+25°C)	Detailed Information see Application Notes chapter "MTBF"	using MIL-HDBK 217F	850 x 10 ³ hours
(+75°C)		using MIL-HDBK 217F	206 x 10 ³ hours
Certifications			
UL General Safety	Report: E358085		UL 60950-1 1st Ed. C22.2 No. 60950-1-03
EN General Safety	Report: SPLVD1212007	EN60950-1:2006 + 9+A1:2010+A12:2011	
EN Medical Safety	Report: MDD1205098-3 + RM1205098-3		IEC/EN 60601-1 3rd Edition, Medical Report + ISO14971 Risk Assessment

Isolation Restrictions

"B" Pinning is restricted to 1.6kV isolation due to the closeness of the input and output pins.

If the options "/M" for metal case and "/SMD" for SMD pinout are combined, the maximum allowed isolation voltage is 2kVDC because of the shorter distances between pins and the metal case.

DIP-24 through-hole case and SMD-plastic case are not affected and offer the full isolation barriers of 2kV through to 6kVDC.

Ordering Examples:

REC5-0512DRW/H2/A/CTRL= 2:1 input, 5V Vin, $\pm 12\text{V}$ Vout, 2kVDC, pinout "A", plastic case, control pin

REC5-4812SRWZ/H4/A/M = 4:1 input, 48V Vin, 12V Vout, 4kVDC, pinout "A", metal case, no control pin

REC5-1212DRWZ/H/B = 4:1 input, 12V Vin, $\pm 12\text{V}$ Vout, 1.6kVDC, pinout "B", plastic case, no control pin

REC5-0505SRW/H6/C/SMD = 2:1 input, 5V Vin, 5V Vout, 6kVDC, SMD pinout "C", plastic case, no control pin

**Any data referred to in this datasheet are of indicative nature and based on our practical experience only. For further details, please refer to our Application Notes.

Notes

Note 1: Maximum capacitive load is defined as the capacitive load that will allow start up in under 1 second without damage to the converter.

Note 2: The REC 5 series require a minimum of 10% loading on the output to maintain specified regulation. Operating under un-load condition will not damage these devices, however they may not meet all listed.

Typical Characteristics

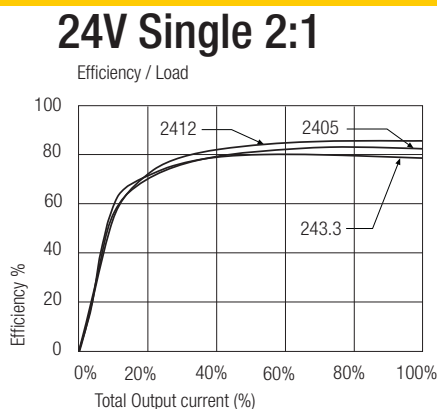
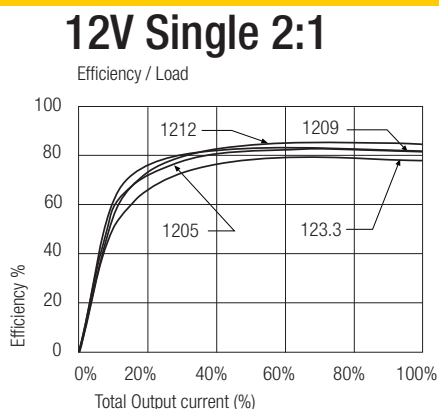

Typical Characteristics

48V Single 2:1

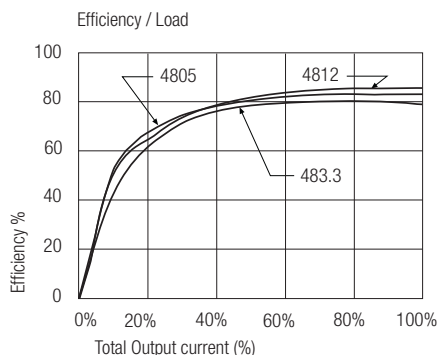

Dual 4:1

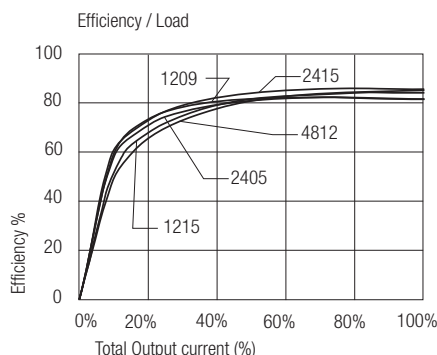

Package Style and Pinning (mm) DIP 24 , Wide Input 2:1 & 4:1

"A" Pinning

/H2, /H4 & /H6

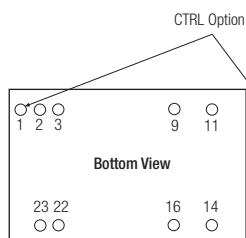
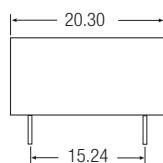
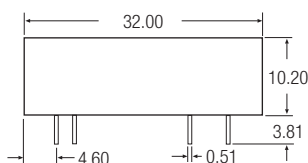

Recommended Footprint Details

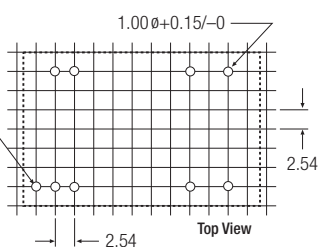

Pin Connections

Pin #	Single	Single/X2	Dual
1 (option)	CTRL	CTRL	CTRL
2	-Vin	-Vin	-Vin
3	-Vin	-Vin	-Vin
9	NC	No Pin	Com
11	NC	NC	-Vout
14	+Vout	+Vout	+Vout
16	-Vout	-Vout	Com
22	+Vin	+Vin	+Vin
23	+Vin	+Vin	+Vin

NC = No Connection

XX.X ± 0.5 mm

XX.XX ± 0.25 mm

CTRL Option

ON = Open or $0V < V_{ctrl} < 1.2V$
OFF = $2.2V < V_{ctrl} < 12V$

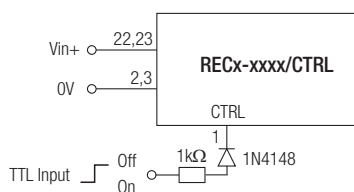

"C" Pinning

/H2, /H4 & /H6

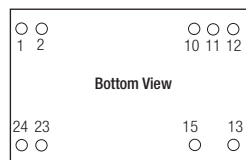
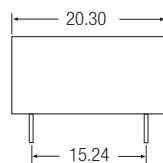
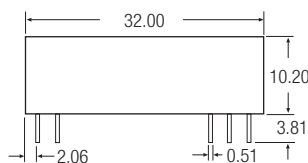

Recommended Footprint Details

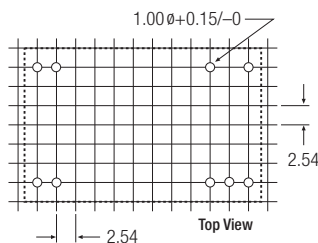

Pin Connections

Pin #	Single	Dual
1	+Vin	+Vin
2	+Vin	+Vin
10	NC	Com
11	NC	Com
12	-Vout	NC
13	+Vout	-Vout
15	NC	+Vout
23	-Vin	-Vin
24	-Vin	-Vin

NC = No Connection

XX.X ± 0.5 mm

XX.XX ± 0.25 mm

Package Style and Pinning (mm) DIP 24 , Wide Input 2:1 & 4:1

"B" Pinning /H (1.6kV Only)

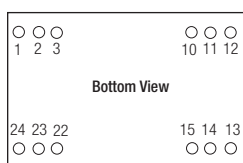
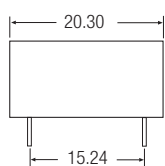
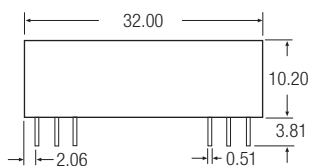

Recommended Footprint Details

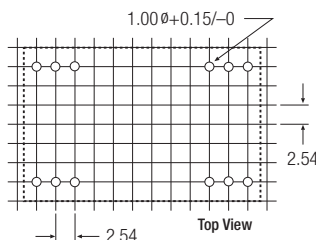

Pin Connections

Pin #	Single	Dual
1	+Vin	+Vin
2	No Pin	-Vout
3	No Pin	Com
10	-Vout	Com
11	+Vout	+Vout
12	-Vin	-Vin
13	-Vin	-Vin
14	+Vout	+Vout
15	-Vout	Com
22	No Pin	Com
23	No Pin	-Vout
24	+Vin	+Vin

NC = No Connection

XX.X ± 0.5 mm

XX.XX ± 0.25 mm

SMD Pinning

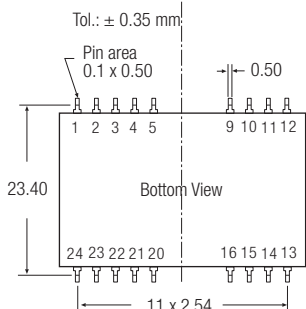
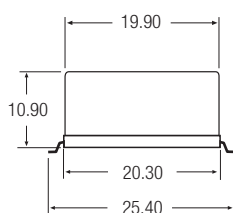
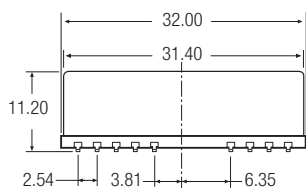

Recommended Footprint Details

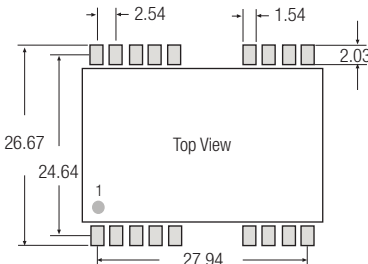

SMD pin connections follow standard package A (/A/SMD), B (/B/SMD) or C (/C/SMD) pinning.

All unused pins are NC (No Connection). See Below for detailed pinout lists

for all packages incl.SMD case the length of plastic case is 31,8 mm, length of metal case 32.0 mm

/A/SMD Pinning

/B/SMD Pinning

/C/SMD Pinning

Pin Connections

Pin #	Single	Dual
1 (Option)	CTRL	CTRL
2	-Vin	-Vin
3	-Vin	-Vin
4	NC	NC
5	NC	NC
9	NC	Com
10	NC	NC
11	NC	-Vout
12	NC	NC

Pin Connections

Pin #	Single	Dual
13	NC	NC
14	+Vout	+Vout
15	NC	NC
16	-Vout	Com
20	NC	NC
21	NC	NC
22	+Vin	+Vin
23	+Vin	+Vin
24	NC	NC

Pin Connections

Pin #	Single	Dual
1	+Vin	+Vin
2	NC	-Vout
3	NC	Com
4	NC	NC
5	NC	NC
9	NC	NC
10	-Vout	Com
11	+Vout	+Vout
12	-Vin	-Vin

Pin Connections

Pin #	Single	Dual
13	-Vin	-Vin
14	+Vout	+Vout
15	-Vout	Com
16	NC	NC
20	NC	NC
21	NC	NC
22	NC	Com
23	NC	-Vout
24	+Vin	+Vin

Pin Connections

Pin #	Single	Dual
1	+Vin	+Vin
2	+Vin	+Vin
3	NC	NC
4	NC	NC
5	NC	NC
9	NC	NC
10	NC	Com
11	NC	Com
12	-Vout	NC

Pin Connections

Pin #	Single	Dual
13	+Vout	-Vout
14	NC	NC
15	NC	+Vout
16	NC	NC
20	NC	NC
21	NC	NC
22	NC	NC
23	-Vin	-Vin
24	-Vin	-Vin

Features

Regulated Converters

- 8kVDC & 10kVDC Reinforced Isolation
- Industry Standard DIP24 Package
- 6W Regulated Output
- Continuous Short Circuit Protection
- Wide Input 2:1
- Medical Approved
- EN, CSA and CB Certificates
- 2 Pinout Options
- Control Pin Option
- Efficiency to 86%

Description

The REC6 series uses a reinforced isolation transformer to offer exceptionally high isolation of 8kVDC (4kVAC/1 minute) or 10kVDC (5kVAC/1minute) making it suitable for HT monitoring circuits, mains power meters, IGBT isolated power supplies and other sophisticated industrial and medical applications. The isolation capacitance of only 20pF makes them also suitable for low leakage applications. The isolation transformer is recognised by CSA as reinforced isolated with a minimum internal clearance of 2.4mm and a minimum internal creepage clearance of 4.6mm. The REC6 is available in two industry-standard pinouts (= "/A" or "/C"). Remote on/off control is possible with the /CTRL option (A pinning only) and an optional undervoltage lockout function is also available (= "/X1"). The converters can deliver 140% rated power for short periods of time to cope with applications with large capacitive loads or high start up currents.

Selection Guide

Part Number DIP24	Input Voltage (VDC)	Output Voltage (VDC)	Output Current (mA)	Efficiency (%)	Max Capacitive Load ⁽¹⁾
REC6-xx05SRW/R*	9 - 18, 18 - 36, 36 - 75 4.5 - 9	5	1000	80, 81, 82 77	6800µF
REC6-xx09SRW/R*	9 - 18, 18 - 36, 36 - 75 4.5 - 9	9	667 555	81, 82, 83 80	6800µF
REC6-xx12SRW/R*	9 - 18, 18 - 36, 36 - 75 4.5 - 9	12	500 417	82, 83, 84 82	6800µF
REC6-xx15SRW/R*	9 - 18, 18 - 36, 36 - 75 4.5 - 9	15	400 333	84, 85, 86 83	6800µF
REC6-xx24SRW/R*	9 - 18, 18 - 36, 36 - 75 4.5 - 9	24	250 208	83, 84, 85 82	4700µF
REC6-xx05DRW/R*	9 - 18, 18 - 36, 36 - 75 4.5 - 9	±5	±500	80, 81, 82 77	±2200µF
REC6-xx09DRW/R*	9 - 18, 18 - 36, 36 - 75 4.5 - 9	±9	±335 ±278	81, 82, 83 80	±2200µF
REC6-xx12DRW/R*	9 - 18, 18 - 36, 36 - 75 4.5 - 9	±12	±250 ±208	81, 82, 83 82	±2200µF
REC6-xx15DRW/R*	9 - 18, 18 - 36, 36 - 75 4.5 - 9	±15	±200 ±167	82, 83, 84 80	±2200µF

R* = R8 or R10 for 8kVDC or 10kVDC isolation.

Note 1: Maximum capacitive load is defined as the capacitive load that will allow start up in under 1 second without damage to the converter.

* add suffix "/A" or "/C" for pinning options, see next page for details.

* add suffix "/CTRL" for control pin option (A Pinning only)

* add suffix "/X1" for Undervoltage Lockout

2:1 Input

(REC6-S_DRW/R8(R10))

xx = 4.5-9Vin = 05

xx = 9-18Vin = 12

xx = 18-36Vin = 24

xx = 36-75Vin = 48

Ordering Examples:

REC6-0512DRW/R8/A/CTRL= 5V Vin, ±12V Vout, 8kVDC isolation, pinout "A", control pin

REC6-4805SRW/R10/A = 48V Vin, 5V Vout, 10kVDC isolation, pinout "A"

REC6-1212DRW/R8/C/X1 = 12V Vin, ±12V Vout, 8kVDC isolation, pinout "C", UVL

REC6-0505SRW/R10/A/CTRL/X1 = 5V Vin, 5V Vout, 10kVDC isolation, pinout "A", control pin, UVL

ECONOLINE

DC/DC-Converter

with 3 year Warranty

RECOM

6 Watt DIP24 Reinforced Single & Dual Output



C22.2-No. 60950 Certified
C22.2-601.1 Certified
UL-60601.1 Certified

REC6/R

Derating-Graph (Ambient Temperature)

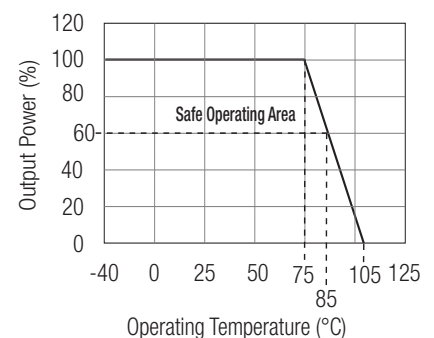

Refer to Application Notes

Specifications (measured at $T_A = 25^\circ\text{C}$, nominal input voltage, full load and after warm-up)

Input Voltage Range			2:1	
Output Voltage Accuracy			$\pm 2\%$ max.	
Line Regulation	(HL-LL)		$\pm 0.3\%$ max.	
Load Regulation	(for output load current change from 20% to 100%)		$\pm 0.6\%$ max.	
Input Surge	(1 minute)	5V types	16V max.	
		12V types	25V max.	
		24V types	50V max.	
		48V types	100V max.	
Undervoltage Lockout	(X1 Versions)	5V types	3.5V typ. ($\pm 20\%$)	
		12V types	7V typ. ($\pm 20\%$)	
		24V types	15V typ. ($\pm 10\%$)	
		48V types	32V typ. ($\pm 10\%$)	
Output Ripple and Noise	(0,1 μF capacitor on output, 20MHz BW limited)		200mVp-p max.	
Transient Response	(25% step change)		1ms typ.	
Switching Frequency	(Full load and nominal input voltage)		100kHz min. / 350kHz max.	
Input Filter			Pi Network	
Capacitors	All types		MLCC capacitors only	
Minimum Load	(Operation under no load will not damage the converter, but it may not meet all specifications)		20% Full Load	
No Load Power Consumption			400mW max.	
Isolation Voltage	R8-Suffix	(tested for 1 second)	8000VDC	
		(rated for 1 minute**)	4000VAC / 60Hz	
Isolation Voltage	R10-Suffix	(tested for 1 second)	10000VDC	
		(rated for 1 minute**)	5000VAC / 60Hz	
Isolation Capacitance			20pF typ.	
Isolation Resistance			10 G Ω min.	
Short Circuit Protection	(Max operating temp. = 50°C during short circuit conditions)		Continuous, Auto Restart	
Operating Temperature Range	(free air convection)		-40°C to $+75^\circ\text{C}$ (see Graph)	
Case Temperature			105°C max.	
Storage Temperature Range			-55°C to $+125^\circ\text{C}$	
Relative Humidity			95% RH	
Case Material			Non-Conductive Plastic	
Potting Material			Silicone	
Thermal Impedance	Natural convection		$20^\circ\text{C}/\text{W}$	
Package Weight			14g	
Packing Quantity			15 pcs per Tube	
MTBF ($+25^\circ\text{C}$)	} <i>Detailed Information see</i>	using MIL-HDBK 217F	953×10^3 hours	
		using MIL-HDBK 217F	234×10^3 hours	
($+75^\circ\text{C}$)	} <i>Application Notes chapter "MTBF"</i>			
EMC	Conducted Emissions	EN55022	Class A	
	Radiated Emissions	EN55022	Class A	
(with 470 μF /0.1 μF capacitors across input)				
Reinforced Isolation	Transformer Creepage	/R8 and /R10 Types	4.6 mm min.	
	Transformer Clearance	/R8 and /R10 Types	2.4 mm min.	
	PCB Creepage & Clearance	/R8 and /R10 Types	6.0 mm min.	
	Optocoupler Creepage	/R8 and /R10 Types	6.0 mm min.	
External Creepage and Clearance	Plastic Case	Input <> Output pins	14.2 mm min.	
Certifications	EN Medical Safety	Report: MDD1207051 + RM1207051	EN 60601-1 3rd Edition	
		Medical Report + ISO14971 Risk Assessment		
	IEC Medical Safety	CB-Report: CA-10168-A1-UL	IEC60601-1 3rd Edition	
	CSA	Medical Safety	Report: 2202478	C22.2 601-1 2nd Ed.
	UL	Medical Safety	E314885-A4	UL 60601-1 3rd Edition
		General Safety	Report: 2219431	C22.2 No. 60950-1-03
	UL 60950-1 1st Ed.	Recognised as Reinforced Isolation	Supplement to Report: 2219431	

**Any data referred to in this datasheet are of indicative nature and based on our practical experience only. For further details, please refer to our Application Notes.

Typical Characteristics

Efficiency vs Load

REC6-xx05SRW/R*
REC6-xx05DRW/R*

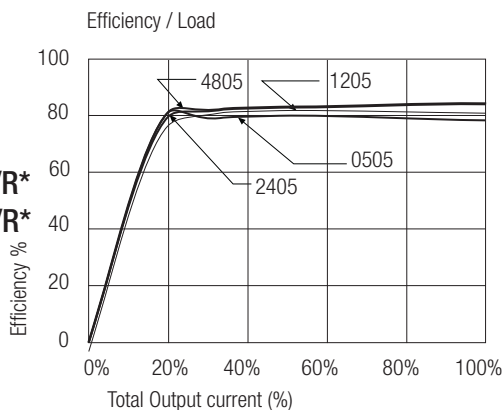

Efficiency vs Vin

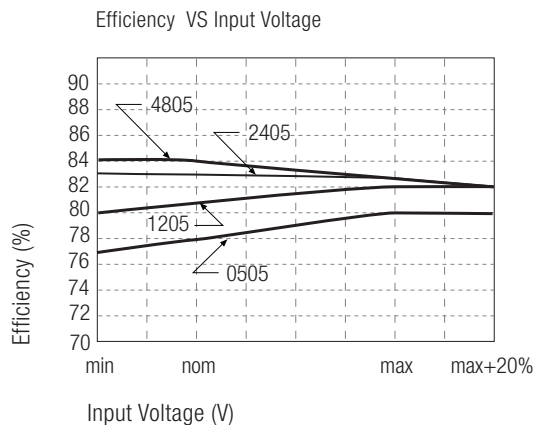

Efficiency / Load

REC6-xx12SRW/R*

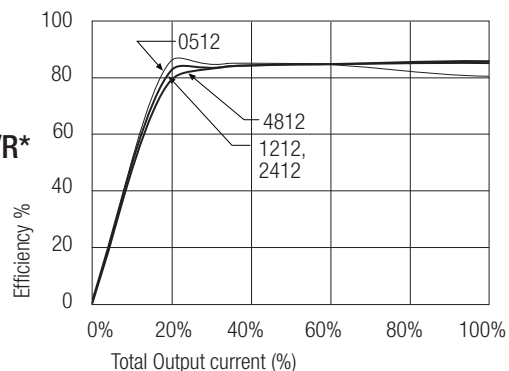

Efficiency VS Input Voltage

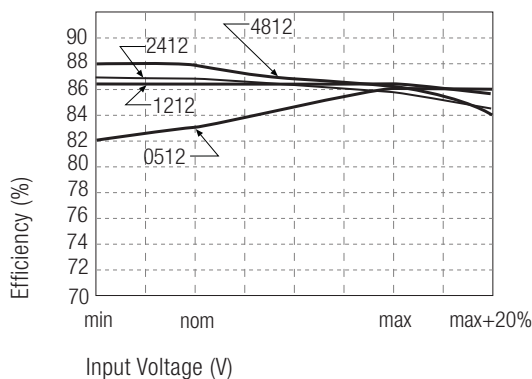

Efficiency / Load

REC6-xx24SRW/R*
REC6-xx12DRW/R*

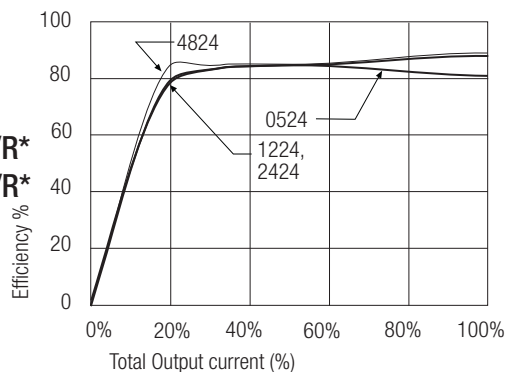

Efficiency VS Input Voltage

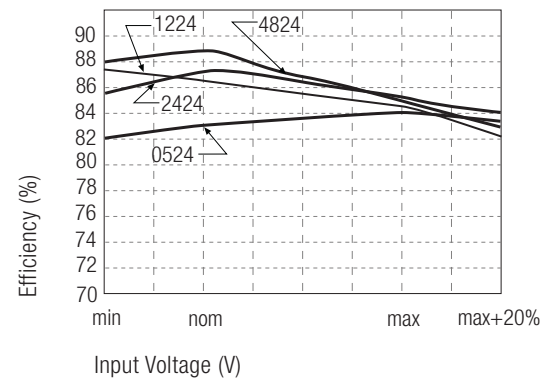

"A" Pinning /R8 & /R10

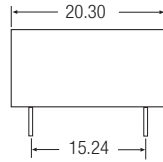
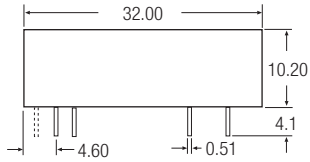

Recommended Footprint Details

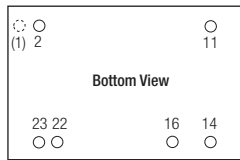

CTRL Version only

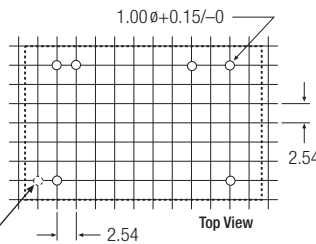

Pin Connections

Pin #	Single	Dual
1 (option)	CTRL	CTRL
2	-Vin	-Vin
11	NC	-Vout
14	+Vout	+Vout
16	-Vout	Com
22	+Vin	+Vin
23	+Vin	+Vin

NC = No Connection

XX.X ± 0.5 mm
XX.XX ± 0.25 mm

CTRL Option

ON = Open or $0V < V_{ctrl} < 1.2V$
OFF = $2.2V < V_{ctrl} < 12V$

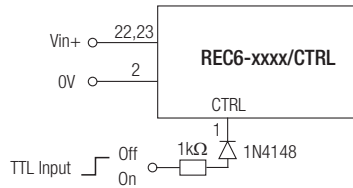

"C" Pinning /R8 & /R10

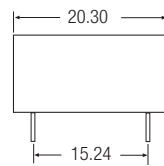
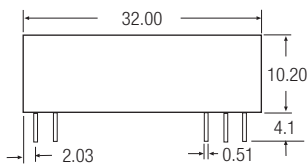

Recommended Footprint Details

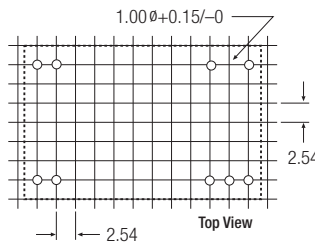
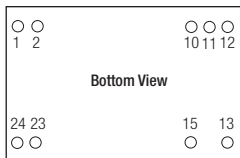

Pin Connections

Pin #	Single	Dual
1	+Vin	+Vin
2	+Vin	+Vin
10	NC	Com
11	NC	Com
12	-Vout	NC
13	+Vout	-Vout
15	NC	+Vout
23	-Vin	-Vin
24	-Vin	-Vin

NC = No Connection

XX.X ± 0.5 mm
XX.XX ± 0.25 mm

Features

Regulated Converters

- 7.5W DIP24 Package
- 1KVDC, 2KVDC and 3kVDC Isolation Options
- Approved for Medical Applications (/H)
- UL and EN Safety Approvals
- Continuous Short Circuit Protection (power limiting)
- 5 Side Shielded Metal Case
- Full SMD design
- 2 Case Style Options
- Remote Pin Option
- Efficiency to 86 %

Description

The REC7.5-xxxSRW/DRW-series offer single and dual regulated outputs in a DIP24 package with 1kV, 2kV or 3kV options and are suitable for higher power industrial or medical applications. Remote on/off control is possible with the /CTRL option and SMD pinning is offered with the /SMD option. The converters can deliver 140% rated power for short periods of time to cope with applications with large capacitive loads or high start up currents.

Selection Guide

Part Number	Input Voltage (VDC)	Output Voltage (VDC)	Output Current (mA)	Efficiency (%)	Max Capacitive Load (1)
REC7.5-xx3.3SRW/H*/A/M	9-18, 18-36, 36-72	3.3	1800	78	6800µF
REC7.5-xx05SRW/H*/A/M	9-18, 18-36, 36-72	5	1500	79-82	6800µF
REC7.5-xx09SRW/H*/A/M	9-18, 18-36, 36-72	9	833	81-84	6800µF
REC7.5-xx12SRW/H*/A/M	9-18, 18-36, 36-72	12	625	82-85	6800µF
REC7.5-xx15SRW/H*/A/M	9-18, 18-36, 36-72	15	500	83-86	6800µF
REC7.5-xx05DRW/H*/A/M	9-18, 18-36, 36-72	±5	±750	79-82	±2200µF
REC7.5-xx09DRW/H*/A/M	9-18, 18-36, 36-72	±9	±417	81-84	±2200µF
REC7.5-xx12DRW/H*/A/M	9-18, 18-36, 36-72	±12	±312	82-85	±2200µF
REC7.5-xx15DRW/H*/A/M	9-18, 18-36, 36-72	±15	±250	83-86	±2200µF

* add suffix /H1 for 1kVDC Isolation, /H2 for 2kVDC isolation or /H3 for 3kVDC Isolation (not available in H3/A/M/SMD combination)

* add suffix "/SMD" for SMD package, e.g. REC7.5-2405DRW/H1/A/M/SMD

* add suffix "/CTRL" for Remote Pin option
no plastic case is available for REC7.5

2:1

xx = 9-18Vin = 12V,

xx = 18-36Vin = 24,

xx = 36-72Vin = 48

Specifications (measured at $T_A = 25^\circ\text{C}$, nominal input voltage, full load and after warm-up)

Single

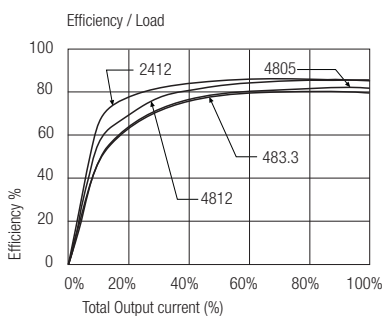

Dual

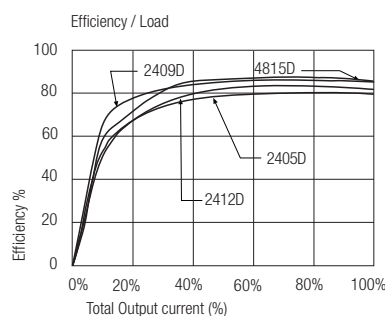

ECONOLINE

DC/DC-Converter

with 3 year Warranty

RECOM

7.5 Watt DIP24 & SMD Single & Dual Output

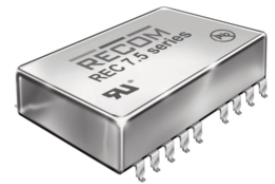

E-358085

EN-60950-1 Certified

EN-60601-1 Certified

(* /H suffix)

UL-60950-1 Certified

REC 7.5

Derating-Graph

(Ambient Temperature)

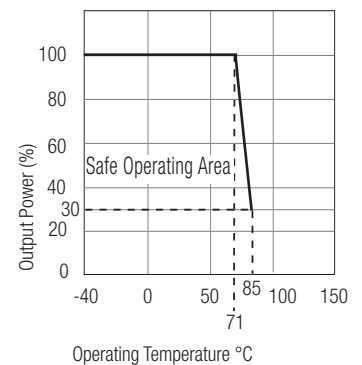

**Any data referred to in this datasheet are of indicative nature and based on our practical experience only. For further details, please refer to our Application Notes.

Refer to Application Notes

Specifications (measured at $T_A = 25^\circ\text{C}$, nominal input voltage, full load and after warm-up)

Input Voltage Range			2:1
Output Voltage Accuracy			$\pm 2\%$ max.
Line Voltage Regulation			0.4% max.
Load Voltage Regulation (25% to 100% full load)			0.8% max.
Minimum Load			10% ⁽²⁾
Output Ripple and Noise (at 20MHz BW)	3.3V output type		100mVp-p max.
	5, 9, 12 and 15V output types		50mVp-p max.
Operating Frequency (Full Load)			150kHz min. / 240kHz max.
Input Filter			PI Network
Efficiency at Full Load			see Selection Guide
No Load Power Consumption			300mW max.
Isolation Voltage	H1-Suffix	(tested for 1 second) (rated for 1 minute**)	1000VDC
	H2-Suffix	(tested for 1 second) (rated for 1 minute**)	500VAC / 60Hz 2000VDC
	H3-Suffix	(tested for 1 second) (rated for 1 minute**)	1000VAC / 60Hz 3000VDC
		(rated for 1 minute**)	1500VAC / 60Hz
Isolation Capacitance			50pFtyp.
Isolation Resistance			1 G Ω min.
Short Circuit Protection (Max temp. = 50°C during short circuit conditions)			Continuous, Auto Restart
Operating Temperature Range (free air convection)			-40°C to +71°C (see Graph)
Storage Temperature Range			-55°C to +125°C
Relative Humidity			95% RH
Case Material			Nickel Plated Metal with Non-Conductive Base
Thermal Impedance	Natural convection		12°C/W
Package Weight			16g
Packing Quantity			15 pcs per Tube
MTBF (+25°C)	} Detailed Information see Application Notes chapter "MTBF"	using MIL-HDBK 217F	800 x 10 ³ hours
(+71°C)		using MIL-HDBK 217F	>200 x 10 ³ hours
Certifications			
UL General Safety	Report: E358085		UL 60950-1 1st Ed. C22.2 No. 60950-1-03 EN60950-1:2006 +A12:2011
EN General Safety	Report: SPCLVD1212007		
EN Medical Safety	Report: MDD1205098-3 + RM1205098-3 IEC/EN 60601-1 3rd Edition; Medical Report + ISO14971 Risk Assessment		

Notes

Note 1: Maximum capacitive load is defined as the capacitive load that will allow start up in under 1 second without damage to the converter.

Note 2: The REC 7.5 series require a minimum of 10% loading on the output to maintain specified regulation. Operating under un-load condition will not damage these devices, however they may not meet all listed specifications.

Typical Characteristics

Overload Response

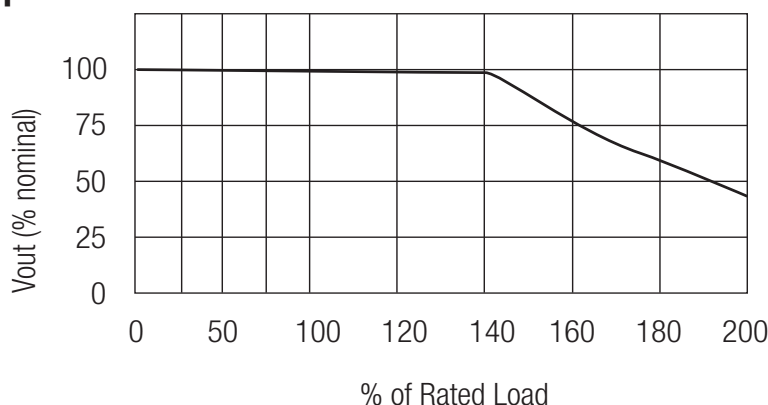

Package Style and Pinning (mm)

24 PIN DIP Package

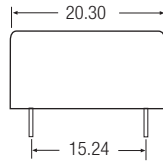
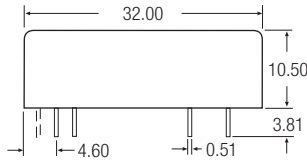

Recommended Footprint Details

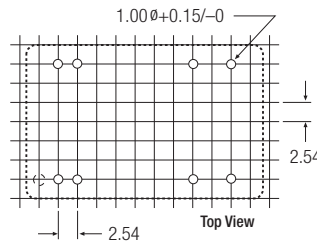
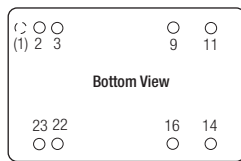

Pin Connections DIP24

Pin #	Single	Dual
1	CTRL/No Pin	CTRL/No Pin
2	-Vin	-Vin
3	-Vin	-Vin
9	NC	Com
11	NC	-Vout
14	+Vout	+Vout
16	-Vout	Com
22	+Vin	+Vin
23	+Vin	+Vin

XX.X ± 0.5 mm
XX.XX ± 0.25 mm

24 PIN SMD Package

/H3/A/M/SMD combination is not allowed

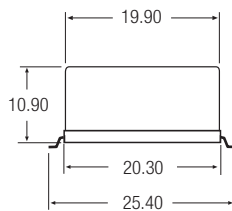
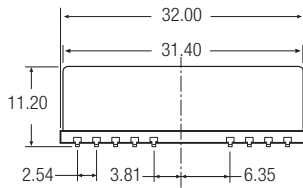

Recommended Footprint Details

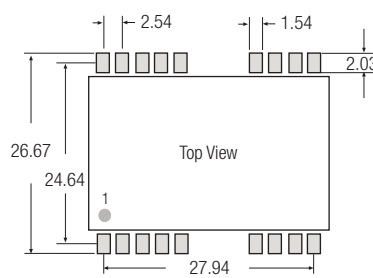
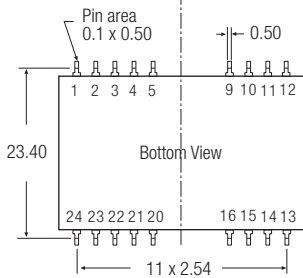

Pin Connections DIP24 SMD

Pin #	Single	Dual
1	CTRL/NC	CTRL/NC
2	-Vin	-Vin
3	-Vin	-Vin
9	NC	Com
11	NC	-Vout
14	+Vout	+Vout
16	-Vout	Com
22	+Vin	+Vin
23	+Vin	+Vin
1,4,5,10,12	NC	NC
13,15,20,21,24	NC	NC

NC = No Connection
XX.X ± 0.5 mm
XX.XX ± 0.25 mm

CTRL Option

ON = Open or $0V < V_{ctrl} < 1.2V$
OFF = $2.2V < V_{ctrl} < 12V$

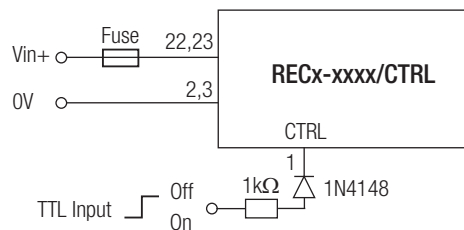

Features

Regulated Converters

- 8W DIP24 Package
- 2KVDC and 3kVDC Isolation Options
- 2:1 and 4:1 Versions
- Continuous Short Circuit Protection (power limiting)
- Synchronous Rectification on 3.3, 5V outputs
- Full SMD internal design
- Through Hole or SMD Pinning Options
- Remote Control Pin
- Efficiency to 87%

Description

The REC8-xxxxSRW/DRW-series offer single and dual regulated outputs in a DIP24 package with 2kV or 3kV isolation options and are suitable for higher power industrial or medical applications. Remote on/off control is standard and SMD pinning is offered with the /SMD option. The converters can deliver 150% rated power for short periods of time to cope with applications with large capacitive loads or high start up currents.

Selection Guide

Part Number	Input Voltage (VDC)	Output Voltage (VDC)	Output Current (mA)	Efficiency (%)	Max. Capacitive Load
REC8-xx3.3SRW/H*/A/M	4.5-9, 9-18, 18-36, 36-75	3.3	1600	83-85	2200µF
REC8-xx05SRW/H*/A/M	4.5-9, 9-18, 18-36, 36-75	5	1600	85-87	2200µF
REC8-xx12SRW/H*/A/M	4.5-9, 9-18, 18-36, 36-75	12	666	84-86	470µF
REC8-xx15SRW/H*/A/M	4.5-9, 9-18, 18-36, 36-75	15	533	84-86	220µF
REC8-xx05DRW/H*/A/M	9-18, 18-36, 36-75	±5	±800	84	±1000µF
REC8-xx12DRW/H*/A/M	4.5-9, 9-18, 18-36, 36-75	±12	±333	84-86	±220µF
REC8-xx15DRW/H*/A/M	4.5-9, 9-18, 18-36, 36-75	±15	±267	84-86	±100µF
REC8-xx3.3SRWZ/H*/A/M	9-36, 18-75	3.3	1600	84	2200µF
REC8-xx05SRWZ/H*/A/M	9-36, 18-75	5	1600	86	2200µF
REC8-xx12SRWZ/H*/A/M	9-36, 18-75	12	666	85	470µF
REC8-xx15SRWZ/H*/A/M	9-36, 18-75	15	533	85	220µF
REC8-xx05DRWZ/H*/A/M	9-36, 18-75	±5	±800	83	±1000µF
REC8-xx12DRWZ/H*/A/M	9-36, 18-75	±12	±333	85	±220µF
REC8-xx15DRWZ/H*/A/M	9-36, 18-75	±15	±267	85	±100µF

* Standard is /H2 for 2kVDC isolation, use /H3 for 3kVDC Isolation (not SMD)

* add suffix "/SMD" for SMD package, e.g. REC8-2405SRW/H2/A/M/SMD

2:1	4:1
xx = 4.5-9Vin = 05,	xx = 9-36Vin = 24,
xx = 9-18Vin = 12,	xx = 18-75Vin = 48
xx = 18-36Vin = 24,	
xx = 36-75Vin = 48	

Specifications (measured at T_A = 25°C, nominal input voltage, full load and after warm-up)

Input Voltage Range	2:1 & 4:1
Input Filter	PI Network
Output Voltage Accuracy	±1.5% max.
Line Voltage Regulation (V _L to V _H at full load)	±0.5% max.
Load Voltage Regulation (25% to 100% full load)	Single ±0.5% max. Dual ±1.2% max.
Cross Regulation (100%: 25% to 100% full load)	±5% max.
Output Ripple and Noise (with 100n output capacitor and 20MHz BW)	50mVp-p max.
Start-up time	300ms typ.
Operating Frequency (Full Load)	330kHz typ.
Efficiency at Full Load	see Selection Guide
Minimum Load	10% ⁽¹⁾

continued on next page

ECONOLINE

DC/DC-Converter

with 3 year Warranty

RECOM

8 Watt DIP24 & SMD Single & Dual Output

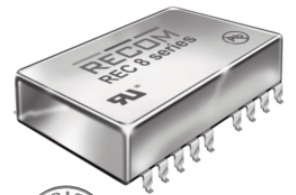

EN-60950-1 Certified
UL-60950-1 Certified
EN-60601-1 Certified

REC8

Note 1:

The REC 8 series require a minimum of 10% loading on the output to maintain specified regulation.

Operating under un-load condition will not damage these devices, however they may not meet all listed specifications.

Refer to Application Notes

www.recom-power.com

Specifications cont. (measured at $T_A = 25^\circ\text{C}$, nominal input voltage, full load and after warm-up)

Input Surge Voltage (100ms max.)	5V Input	15VDC	
	12V Input	36VDC	
	24V Input	50VDC	
	48V Input	100VDC	
Isolation Voltage	H2-Suffix and SMD	(tested for 1 second) (rated for 1 minute**)	2000VDC 1000VAC / 60Hz
	H3-Suffix	(tested for 1 second) (rated for 1 minute**)	3000VDC 1500VAC / 60Hz
Isolation Capacitance			1200pF typ.
Isolation Resistance			1 G Ω min.
Overload Protection			150% typ.
Short Circuit Protection			Continuous, Auto Restart
Operating Temperature Range (free air convection)	4:1	-40°C to +71°C (see Graph)	
	2:1 - Vin=5V	-40°C to +71°C (see Graph)	
	2:1 - All Others	-40°C to +85°C (see Graph)	
Remote On/Off	DC/DC ON	Open or $3.5\text{V} < V_r < 12\text{V}$	
	DC/DC OFF	Short or $0\text{V} < V_r < 1.2\text{V}$	
Storage Temperature Range		-55°C to +105°C	
Temperature Coefficient		$\pm 0.05\%$ max.	
Relative Humidity		95% RH max.	
Case Material		Nickel Plated Metal with Non-Conductive Base	
Thermal Impedance	Natural convection	12°C/W	
Maximum Case Temperature		100°C	
Vibration		10-55Hz, 2G, 30mins along X,Y & Z	
Package Weight		18g	
Packing Quantity		15 pcs per Tube	
MTBF (+25°C) (+71°C)	Detailed Information see Application Notes chapter "MTBF"	using MIL-HDBK 217F	1200 x 10 ³ hours
		using MIL-HDBK 217F	>300 x 10 ³ hours
Certifications			
EN General Safety	Report: SPLCLVD1211033-2	EN60950-1:2006 +A12:2011	
UL General Safety	Report: E224736	UL 60950-1 1st Ed. C22.2 No. 60950-1-03	
EN Medical Safety	Report: MDD12060585 + RM1206085	IEC/EN 60601-1 3rd Edition Medical Report + ISO14971 Risk Assessment	

Derating-Graph (Ambient Temperature)

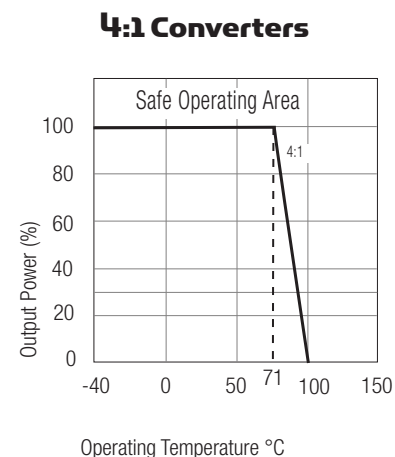
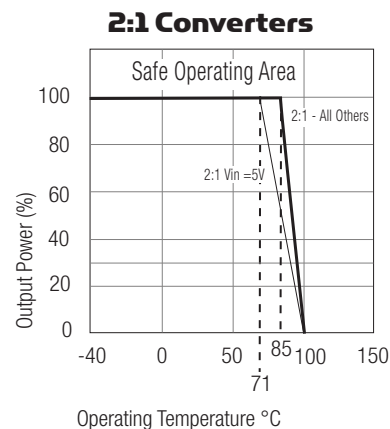

**Any data referred to in this datasheet are of indicative nature and based on our practical experience only. For further details, please refer to our Application Notes.

Typical Characteristics

REC8-1205SRW/H2/A/M (/SMD) REC8-1212SRW/H2/A/M (/SMD)

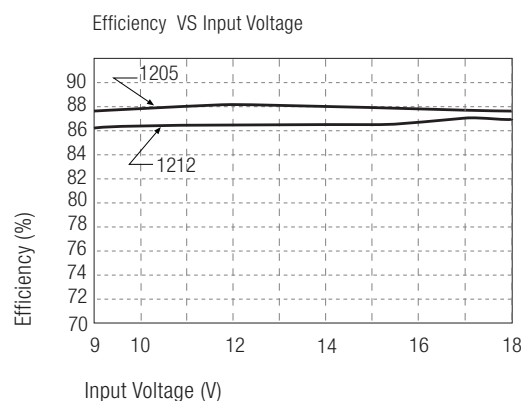
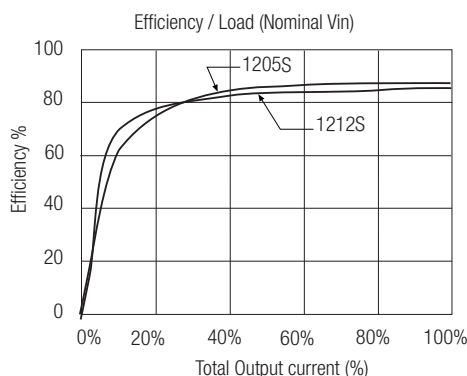

Note: Refer to Application Notes for EMC Class B Filter suggestion

Package Style and Pinning (mm)

24 PIN DIP Package - Available with /H2 and /H3 Options

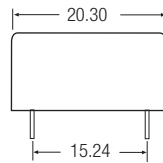
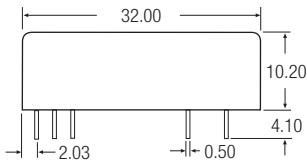

Recommended Footprint Details

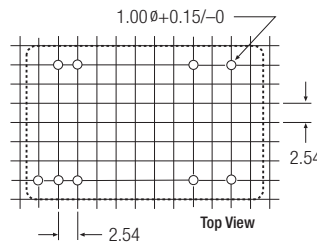
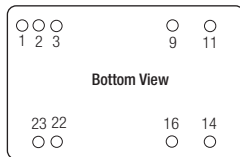

Pin Connections DIP24

Pin #	Single	Dual
1	CTRL	CTRL
2	-Vin	-Vin
3	-Vin	-Vin
9	NC	Com
11	NC	-Vout
14	+Vout	+Vout
16	-Vout	Com
22	+Vin	+Vin
23	+Vin	+Vin

NC = No Connection

XX.X ± 0.5 mm

XX.XX ± 0.25 mm

24 PIN SMD Package - available with /H2 option only.

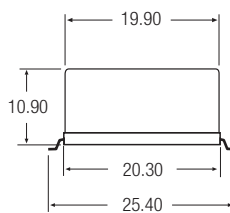
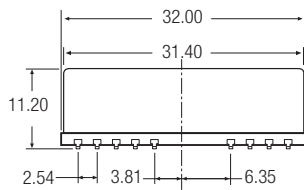

Recommended Footprint Details

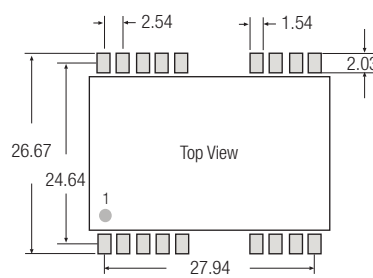
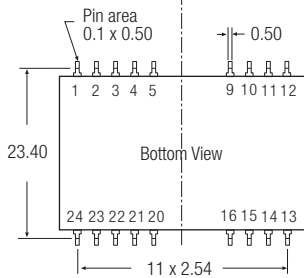

Pin Connections DIP24 SMD

Pin #	Single	Dual
1	CTRL	CTRL
2	-Vin	-Vin
3	-Vin	-Vin
9	NC	Com
11	NC	-Vout
14	+Vout	+Vout
16	-Vout	Com
22	+Vin	+Vin
23	+Vin	+Vin
4,5,10,12		NC
13,15,20,21,24		NC

NC = No Connection

XX.X ± 0.5 mm

XX.XX ± 0.25 mm

The product information and specifications are subject to change without prior notice. All products are designed for non-safety critical commercial and industrial applications. The Buyer agrees to implement safeguards that anticipate the consequences of any failures that might cause harm, loss of life and/or damage property.

Features

Regulated Converters

- 10W DIP24 Package
- 2KVDC and 3kVDC Isolation Options
- 2:1 and 4:1 Versions
- Continuous Short Circuit Protection (power limiting)
- Synchronous Rectification on 3.3, 5V outputs
- Full SMD internal design
- Through Hole or SMD Pinning Options
- Remote Control Pin
- Efficiency to 87%

Description

The REC10-xxxxSRW/DRW-series offer single and dual regulated outputs in a DIP24 package with 2kV or 3kV isolation options and are suitable for higher power industrial or medical applications. Remote on/off control is standard and SMD pinning is offered with the /SMD option. The converters can deliver 150% rated power for short periods of time to cope with applications with large capacitive loads or high start up currents.

Selection Guide

Part Number	Input Voltage (VDC)	Output Voltage (VDC)	Output Current (mA)	Efficiency (%)	Max. Cap. Load
REC10-xx3.3SRW/H*/A/M	9-18, 18-36, 36-75	3.3	2000	84-85	2200µF
REC10-xx05SRW/H*/A/M	9-18, 18-36, 36-75	5	2000	86-87	2200µF
REC10-xx12SRW/H*/A/M	9-18, 18-36, 36-75	12	833	85-86	470µF
REC10-xx15SRW/H*/A/M	9-18, 18-36, 36-75	15	667	85-86	220µF
REC10-xx05DRW/H*/A/M	9-18, 18-36, 36-75	±5	±1000	84	±1000µF
REC10-xx12DRW/H*/A/M	9-18, 18-36, 36-75	±12	±416	86	±220µF
REC10-xx15DRW/H*/A/M	9-18, 18-36, 36-75	±15	±333	86	±100µF
REC10-xx3.3SRWZ/H*/A/M	9-36, 18-75	3.3	2000	84	2200µF
REC10-xx05SRWZ/H*/A/M	9-36, 18-75	5	2000	86	2200µF
REC10-xx12SRWZ/H*/A/M	9-36, 18-75	12	833	85	470µF
REC10-xx15SRWZ/H*/A/M	9-36, 18-75	15	667	85	220µF
REC10-xx05DRWZ/H*/A/M	9-36, 18-75	±5	±1000	83	±1000µF
REC10-xx12DRWZ/H*/A/M	9-36, 18-75	±12	±416	85	±220µF
REC10-xx15DRWZ/H*/A/M	9-36, 18-75	±15	±333	85	±100µF

* Standard is /H2 for 2kVDC isolation, use /H3 for 3kVDC Isolation (not SMD)

* add suffix "/X2" for pinning options, see next page.

* add suffix "/SMD" for SMD package, e.g.

REC10-2405SRW/H2/A/M/SMD

2:1

xx = 9-18Vin = 12,

xx = 18-36Vin = 24,

xx = 36-75Vin = 48

4:1

xx = 9-36Vin = 24,

xx = 18-75Vin = 48

Specifications (measured at $T_A = 25^\circ\text{C}$, nominal input voltage, full load and after warm-up)

Input Voltage Range	2:1 & 4:1
Input Filter	PI Network
Output Voltage Accuracy	±1.5% max.
Line Voltage Regulation (V_L to V_H at full load)	±0.5% max.
Load Voltage Regulation (25% to 100% full load)	Single ±0.5% max. Dual ±1.2% max.
Cross Regulation (100%: 25% to 100% full load)	±5% max.
Output Ripple and Noise (with 100n output capacitor and 20MHz BW)	100mVp-p max.
Start-up time	300ms typ.
Operating Frequency (Full Load)	400kHz typ.
Efficiency at Full Load	see Selection Guide
Minimum Load	10% ⁽¹⁾

continued on next page

ECONOLINE

DC/DC-Converter

with 3 year Warranty

RECOM

10 Watt DIP24 & SMD Single & Dual Output



EN-60950-1 Certified

EN-60601-1 Certified

UL-60950-1 Certified

REC10

Note 1:

The REC 10 series requires a minimum of 10% load on the output to maintain specified regulation.

Operating under no-load condition will not damage these devices, however, they may not meet all listed specifications.

Refer to Application Notes

Specifications (measured at $T_A = 25^\circ\text{C}$, nominal input voltage, full load and after warm-up)

Input Surge Voltage (100ms max.)	12V Input	36VDC	
	24V Input	50VDC	
	48V Input	100VDC	
Isolation Voltage	H2-Suffix and SMD	(tested for 1 second) (rated for 1 minute**) 2000VDC	
	H3-Suffix	(tested for 1 second) (rated for 1 minute**) 1000VAC / 60Hz 3000VDC 1500VAC / 60Hz	
Isolation Capacitance	1200pF typ.		
Isolation Resistance	1 G Ω min.		
Overload Protection	150% typ.		
Short Circuit Protection	Continuous, Auto Restart		
Operating Temperature Range (free air convection)	4:1	-40°C to +71°C (see Graph)	
	2:1	-40°C to +81°C (see Graph)	
Remote On/Off	DC/DC ON	Open or $3.5\text{V} < V_r < 12\text{V}$	
	DC/DC OFF	Short or $0\text{V} < V_r < 1.2\text{V}$	
Storage Temperature Range	-55°C to +105°C		
Temperature Coefficient	$\pm 0.05\%$ max.		
Relative Humidity	95% RH		
Case Material	Nickel Plated Metal with Non-Conductive Base		
Thermal Impedance	Natural convection	15°C/W	
Maximum Case Temperature	100°C		
Vibration	10-55Hz, 2G, 30mins along X,Y & Z		
Package Weight	18g		
Packing Quantity	15 pcs per Tube		
MTBF (+25°C) (+71°C)	Detailed Information see Application Notes chapter "MTBF"	using MIL-HDBK 217F	1000 x 10 ³ hours
		using MIL-HDBK 217F	>250 x 10 ³ hours
Certifications			
EN General Safety	Report: SPCLVD1211033-2	EN60950-1:2006 + A12:2011	
UL General Safety	Report: E224736	UL 60950-1 1st Ed.	
		C22.2 No. 60950-1-03	
EN Medical Safety	Report: MDD12060585 + RM1206085	IEC/EN 60601-1 3rd Edition	
		Medical Report + ISO14971 Risk Assessment	

Derating-Graph (Ambient Temperature)

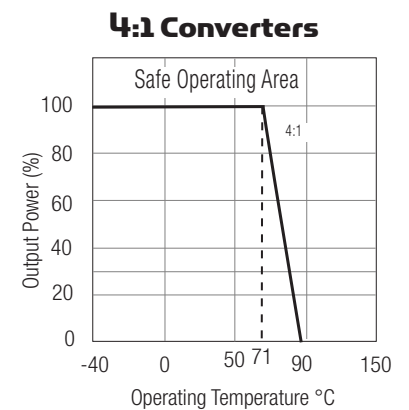
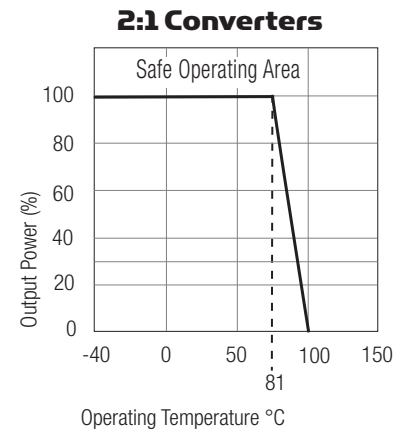

**Any data referred to in this datasheet are of indicative nature and based on our practical experience only. For further details, please refer to our Application Notes.

Typical Characteristics

REC10-1205SRW/H2/A/M (/SMD) REC10-1212SRW/H2/A/M (/SMD)

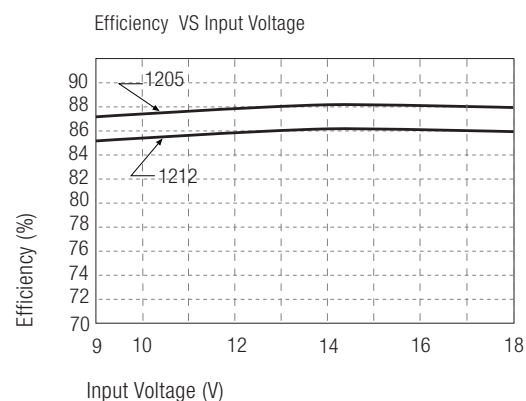
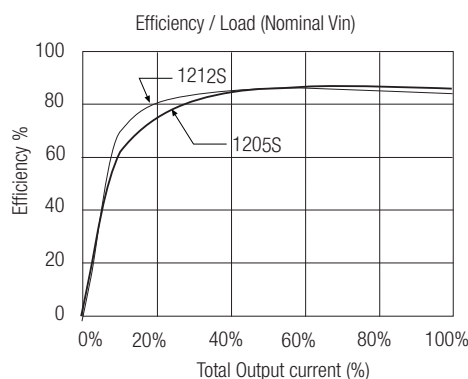

Note: Refer to Application Notes for EMC Class B Filter suggestion

Package Style and Pinning (mm)

24 PIN DIP Package - Available with /H2 and /H3 Options

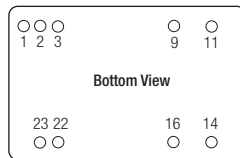
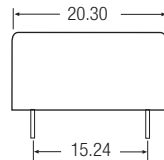
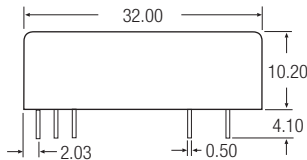

Recommended Footprint Details

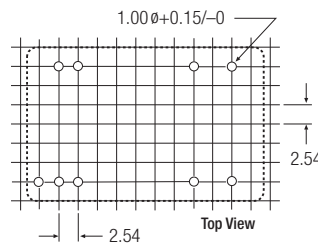

Pin Connections DIP24

Pin #	Single	Single/X2	Dual
1	CTRL	No Pin	CTRL
2	-Vin	-Vin	-Vin
3	-Vin	-Vin	-Vin
9	NC	No Pin	Com
11	NC	NC	-Vout
14	+Vout	+Vout	+Vout
16	-Vout	-Vout	Com
22	+Vin	+Vin	+Vin
23	+Vin	+Vin	+Vin

NC = No Connection

XX.X ± 0.5 mm

XX.XX ± 0.25 mm

24 PIN SMD Package- Only available with /H2 Option

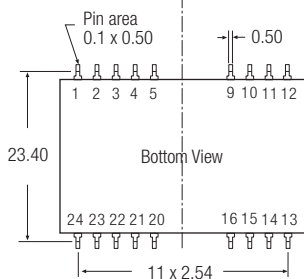
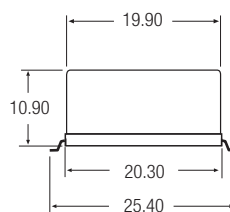
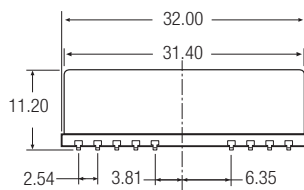

Recommended Footprint Details

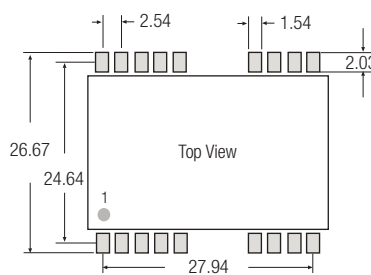

Pin Connections DIP24 SMD

Pin #	Single	Dual
1	CTRL	CTRL
2	-Vin	-Vin
3	-Vin	-Vin
9	NC	Com
11	NC	-Vout
14	+Vout	+Vout
16	-Vout	Com
22	+Vin	+Vin
23	+Vin	+Vin
4,5,10,12	NC	
13,15,20,21,24	NC	

NC = No Connection

XX.X ± 0.5 mm

XX.XX ± 0.25 mm

Features

Regulated Converters

- 10W in 2" x 1" Package
- 2kVDC and 3kVDC Isolation Options
- 2:1 or 4:1 Input Voltage Range
- Continuous Short Circuit Protection (power limiting)
- Synchronous Rectification on all Del outputs
- Full SMD internal design
- Remote Control Pin
- Efficiency to 87%

Description

The REC10-xxxxS_D/M -series offer single and dual regulated outputs in a 2"x1" package with 2kVDC or 3kVDC isolation options and are suitable for higher power industrial applications. Remote on/off control is standard. The converters can deliver 150% rated power for short periods of time to cope with applications with large capacitive loads or high start up currents.

Selection Guide

Part Number	Input Voltage (VDC)	Output Voltage (VDC)	Output Current (mA)	Efficiency (typ.) (%)	Max. Cap. Load
REC10-xx3.3S/H*/M	9-18, 18-36, 36-75	3.3	2000	83-84	2200µF
REC10-xx05S/H*/M	9-18, 18-36, 36-75	5	2000	86-87	2200µF
REC10-xx12S/H*/M	9-18, 18-36, 36-75	12	833	85-86	2200µF
REC10-xx15S/H*/M	9-18, 18-36, 36-75	15	667	85-86	2200µF
REC10-xx05D/H*/M	9-18, 18-36, 36-75	±5	±1000	82-83	±1000µF
REC10-xx12D/H*/M	9-18, 18-36, 36-75	±12	±416	85-86	±1000µF
REC10-xx15D/H*/M	9-18, 18-36, 36-75	±15	±333	85-86	±1000µF
REC10-xx3.3SZ/H*/M	9-36, 18-75	3.3	2000	82	2200µF
REC10-xx05SZ/H*/M	9-36, 18-75	5	2000	86	2200µF
REC10-xx12SZ/H*/M	9-36, 18-75	12	833	85	2200µF
REC10-xx15SZ/H*/M	9-36, 18-75	15	667	86	2200µF
REC10-xx05DZ/H*/M	9-36, 18-75	±5	±1000	82	±1000µF
REC10-xx12DZ/H*/M	9-36, 18-75	±12	±416	85	±1000µF
REC10-xx15DZ/H*/M	9-36, 18-75	±15	±333	86	±1000µF

* Standard is /H2 for 2kVDC isolation, use /H3 for 3kVDC Isolation

2:1

xx = 9-18Vin = 12,
xx = 18-36Vin = 24,
xx = 36-75Vin = 48

4:1

xx = 9-36Vin = 24,
xx = 18-75Vin = 48

Specifications (measured at T_A = 25°C, nominal input voltage, full load and after warm-up)

Input Voltage Range	2:1 or 4:1	
Input Filter	PI Network	
Output Voltage Accuracy (the Output 3.3V is ±1.2% max.)	±1.0% max.	
Line Voltage Regulation	±0.3% max.	
Load Voltage Regulation	Single	±0.5% max.
(25% to 100% full load)	Dual	±1.2% max.
Cross Regulation (100%: 25% to 100% full load)	±5% max.	
Output Ripple and Noise (with 100n output capacitor and 20MHz BW)	100mVp-p max.	
Start-up time (Nom. Vin at 100% Load)	25ms typ.	
Operating Frequency (Full Load)	300kHz typ.	
Efficiency (Nom. Vin at 100% Load)	see Selection Guide	
Minimum Load	10% ⁽¹⁾	
Input Surge Voltage (100ms max.)	12V Input	36VDC
	24V Input	50VDC
	48V Input	100VDC

continued on next page

ECONOLINE

DC/DC-Converter

with 3 year Warranty

RECOM

10 Watt 2" x 1" Single & Dual Output



EN-60950-1 Certified
EN-60601-1 Certified
UL-60950-1 Certified

REC10/M

Note 1:

The REC 10/M series require a minimum of 10% loading on the output to maintain specified regulation.

Operating under un-load condition will not damage these devices, however they may not meet all listed specifications.

Refer to Application Notes

Specifications cont. (measured at $T_A = 25^\circ\text{C}$, nominal input voltage, full load and after warm-up)

Isolation Voltage	H2-Suffix	(tested for 1 second)	2000VDC
	H3-Suffix	(tested for 1 second)	3000VDC
Under Voltage Lockout (2:1)	12V Input	DC-DC on 8.3VDC, DC-DC off 7.9VDC	1000VAC / 60Hz
	24V Input	DC-DC on 17.4VDC, DC-DC off 16.7VDC	3000VDC
	48V Input	DC-DC on 35.7VDC, DC-DC off 34.3VDC	1500VAC / 60Hz
Under Voltage Lockout (4:1)	24V Input	DC-DC on 8.3VDC, DC-DC off 7.9VDC	
	48V Input	DC-DC on 17.4VDC, DC-DC off 16.7VDC	
Isolation Capacitance			1200pF typ.
Isolation Resistance			1 GΩ min.
Overload Protection			150% typ.
Short Circuit Protection			Continuous, Auto Restart
Operating Temperature Range (free air convection)	4:1	-40°C to +71°C (see Graph)	
	2:1	-40°C to +81°C (see Graph)	
Storage Temperature Range			-55°C to +105°C
Remote On/Off	DC/DC ON	Open or 3.5V < V_r < 12V	
	DC/DC OFF	Short or 0V < V_r < 1.2V	
Temperature Coefficient			±0.05% max.
Relative Humidity			95% RH
Case Material			Nickel Plated Metal with Non-Conductive Base
Thermal Impedance	Natural convection	12°C/W	
Maximum Case Temperature			100°C
Vibration			10-55Hz, 2G, 30mins along X,Y & Z
Package Weight			27g
Packing Quantity			10 pcs per Tube
MTBF (+25°C) (+71°C)	Detailed Information see Application Notes chapter "MTBF"	using MIL-HDBK 217F	>1000 x 10 ³ hours
		using MIL-HDBK 217F	>250 x 10 ³ hours
Certifications			
EN General Safety	Report: SPCLVD1211033-2	EN60950-1:2006 + A12:2011	
UL General Safety	Report: E224736	UL 60950-1 1st Ed. C22.2 No. 60950-1-03	
EN Medical Safety	Report: MDD12060585 + RM1206085	IEC/EN 60601-1 3rd Edition; Medical Report + ISO14971 Risk Assessment	

Derating-Graph (Ambient Temperature)

2:1 Converters

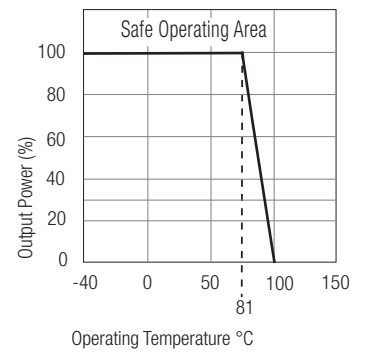

4:1 Converters

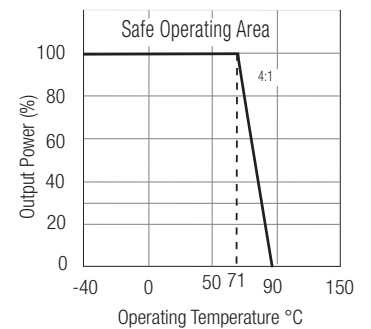

**Any data referred to in this datasheet are of indicative nature and based on our practical experience only. For further details, please refer to our Application Notes.

Note: Refer to Application Notes for EMC Class B Filter suggestion

Package Style and Pinning (mm)

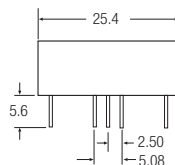
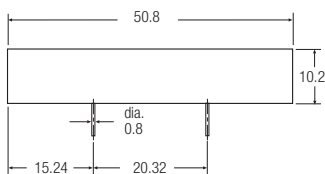

Pin Connections

Pin #	Single	Dual
1	+Vin	+Vin
2	-Vin	-Vin
3	+Vout	+Vout
4	No Pin	Com
5	-Vout	-Vout
6	CTRL	CTRL

XX.X ± 0.5 mm
XX.XX ± 0.35 mm

2" x 1" Package

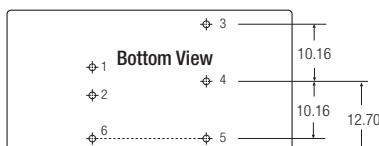

The product information and specifications are subject to change without prior notice. All products are designed for non-safety critical commercial and industrial applications. The Buyer agrees to implement safeguards that anticipate the consequences of any failures that might cause harm, loss of life and/or damage property.

Features

Regulated Converters

- 15W in 2" x 1" Package
- 2kVDC and 3kVDC Isolation Options
- 2:1 or 4:1 Input Voltage Range
- Continuous Short Circuit Protection (power limiting)
- Synchronous Rectification on 3.4V & 5.1V outputs
- Full SMD internal design
- Remote Control Pin
- Efficiency to 87%

Description

The REC15-xxxxS_D/M -series offer single and dual regulated outputs in a 2"x1" package with 2kVDC or 3kVDC isolation options and are suitable for higher power industrial applications. Remote on/off control is standard. The converters can deliver 150% rated power for short periods of time to cope with applications with large capacitive loads or high start up currents. The outputs with 3A load current have raised output voltages to compensate for track losses as standard.

Selection Guide

Part Number	Input Voltage (VDC)	Output Voltage (VDC)	Output Current (mA)	Efficiency (typ.) (%)	Max. Cap. Load
REC15-xx3.4S/H*/M	9-18, 18-36, 36-75	3.4	3000	84-85	3300µF
REC15-xx5.1S/H*/M	9-18, 18-36, 36-75	5.1	3000	86-87	3300µF
REC15-xx12S/H*/M	9-18, 18-36, 36-75	12	1250	85-86	3300µF
REC15-xx15S/H*/M	9-18, 18-36, 36-75	15	1000	85-86	3300µF
REC15-xx05D/H*/M	9-18, 18-36, 36-75	±5	±1500	82-83	±1500µF
REC15-xx12D/H*/M	9-18, 18-36, 36-75	±12	±625	85-86	±1000µF
REC15-xx15D/H*/M	9-18, 18-36, 36-75	±15	±500	85-86	±1000µF
REC15-xx3.4SZ/H*/M	9-36, 18-75	3.4	3000	84-85	3300µF
REC15-xx5.1SZ/H*/M	9-36, 18-75	5.1	3000	87	3300µF
REC15-xx12SZ/H*/M	9-36, 18-75	12	1250	86	3300µF
REC15-xx15SZ/H*/M	9-36, 18-75	15	1000	86	3300µF
REC15-xx05DZ/H*/M	9-36, 18-75	±5	±1500	83	±1500µF
REC15-xx12DZ/H*/M	9-36, 18-75	±12	±625	86	±1000µF
REC15-xx15DZ/H*/M	9-36, 18-75	±15	±500	86	±1000µF

* Standard is /H2 for 2kVDC isolation, use /H3 for 3kVDC Isolation

	2:1	4:1
xx = 9-18Vin = 12,		xx = 9-36Vin = 24,
xx = 18-36Vin = 24,		xx = 18-75Vin = 48
xx = 36-75Vin = 48		

Specifications (measured at T_A = 25°C, nominal input voltage, full load and after warm-up)

Input Voltage Range	2:1 or 4:1	
Input Filter	PI Network	
Output Voltage Accuracy (the Output 3.4V is ±1.2% max.)	±1.0% max.	
Line Voltage Regulation	±0.3% max.	
Load Voltage Regulation	Single	±0.5% max.
(25% to 100% full load)	Dual	±1.2% max.
Cross Regulation (100%: 25% to 100% full load)	±5% max.	
Output Ripple and Noise (with 100n output capacitor and 20MHz BW)	100mVp-p max.	
Start-up time (Nom. Vin at 100% Load)	25ms typ.	
Operating Frequency (Full Load)	300kHz typ.	
Efficiency (Nom. Vin at 100% Load)	see Selection Guide	
Minimum Load	10% (1)	
Input Surge Voltage (100ms max.)	12V Input	36VDC
	24V Input	50VDC
	48V Input	100VDC

continued on next page

ECONOLINE

DC/DC-Converter

with 3 year Warranty

RECOM

15 Watt 2" x 1" Single & Dual Output



EN-60950-1 Certified
EN-60601-1 Certified
UL-60950-1 Certified

REC15/M

Note 1:

The REC 15/M series require a minimum of 10% loading on the output to maintain specified regulation.

Operating under un-load condition will not damage these devices, however they may not meet all listed specifications.

Refer to Application Notes

Specifications (measured at $T_A = 25^\circ\text{C}$, nominal input voltage, full load and after warm-up)

Isolation Voltage	H2-Suffix	(tested for 1 second)	2000VDC
	H3-Suffix	(rated for 1 minute**)	1000VAC / 60Hz
Under Voltage Lockout (2:1)	12V Input	DC-DC on 8.3VDC, DC-DC off 7.9VDC	
	24V Input	DC-DC on 17.4VDC, DC-DC off 16.7VDC	
	48V Input	DC-DC on 35.7VDC, DC-DC off 34.3VDC	
Under Voltage Lockout (4:1)	24V Input	DC-DC on 8.3VDC, DC-DC off 7.9VDC	
	48V Input	DC-DC on 17.4VDC, DC-DC off 16.7VDC	
Isolation Capacitance			1200pF typ.
Isolation Resistance			1 G Ω min.
Overload Protection			150% typ.
Short Circuit Protection			Continuous, Auto Restart
Operating Temperature Range (free air convection)	4:1	-40°C to +65°C (see Graph)	
	2:1	-40°C to +71°C (see Graph)	
Storage Temperature Range			-55°C to +105°C
Remote On/Off	DC/DC ON	Open or $3.5\text{V} < V_r < 12\text{V}$	
	DC/DC OFF	Short or $0\text{V} < V_r < 1.2\text{V}$	
Temperature Coefficient			$\pm 0.05\%$ max.
Relative Humidity			95% RH
Case Material	Nickel Plated Metal with Non-Conductive Base		
Thermal Impedance	Natural convection	12°C/W	
Maximum Case Temperature			100°C
Vibration			10-55Hz, 2G, 30mins along X,Y & Z
Package Weight			27g
Packing Quantity			10 pcs per Tube
MTBF (+25°C)	} Detailed Information see Application Notes chapter "MTBF"	using MIL-HDBK 217F	>700 x 10 ³ hours
		using MIL-HDBK 217F	>150 x 10 ³ hours

Certifications

EN General Safety	Report: SPCLVD 1206084-1	EN60950-1:2006 + A12:2011
UL General Safety	Report: E224736	UL 60950-1 1st Ed. C22.2 No. 60950-1-03
EN Medical Safety	Report: MDD12060585 + RM1206085	IEC/EN 60601-1 3rd Edition; Medical Report + ISO14971 Risk Assessment

Note: Refer to Application Notes for EMC Class B Filter suggestion

Package Style and Pinning (mm)

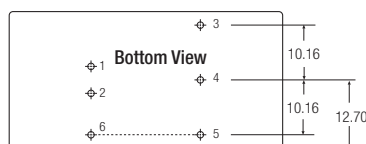
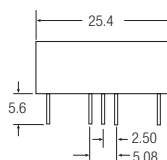
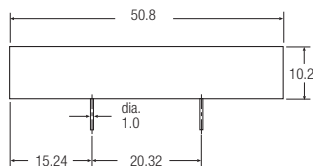

Derating-Graph (Ambient Temperature)

2:1 Converters

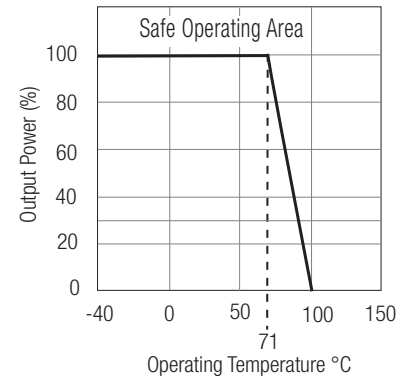

4:1 Converters

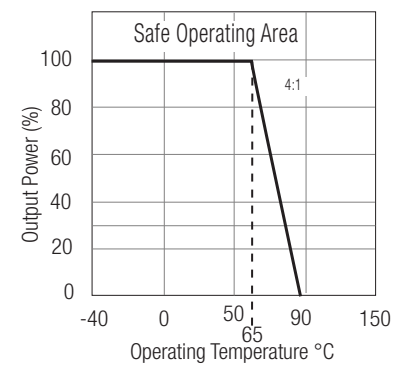

**Any data referred to in this datasheet are of indicative nature and based on our practical experience only. For further details, please refer to our Application Notes.

Pin Connections

Pin #	Single	Dual
1	+Vin	+Vin
2	-Vin	-Vin
3	+Vout	+Vout
4	No Pin	Com
5	-Vout	-Vout
6	CTRL	CTRL

XX.X ± 0.5 mm
XX.XX ± 0.35 mm

The product information and specifications are subject to change without prior notice. All products are designed for non-safety critical commercial and industrial applications. The Buyer agrees to implement safeguards that anticipate the consequences of any failures that might cause harm, loss of life and/or damage property.

INNOLINE - CONTENTS

Switching and High Voltage Regulators



Step Down Switching Regulators

Series	Output Current	Input Voltages (VDC)		Output Voltages (VDC)	No. of Outputs	Case	Page No.
		min.(1)	max.				
R-78xx-0.5	500mA	4.75	34	1.5,1.8,2.5,3.3,5,6.5,9,12,15	S	SIP3	I-2
R-78AAxx-0.5SMD	500mA	4.75	34	1.5,1.8,2.5,3.3,5,6.5,9,12,15	S	SMD OF	I-7
R-78xx-1.0	1A	4.75	18	1.8, 2.5, 3.3, 5	S	SIP3	I-12
R-78AAxx-1.0SMD	1A	4.75	18	1.5,1.8,2.5,3.3,5	S	SMD OF	I-15
R-78Cxx-1.0	1A	8-	42	5, 9, 12, 15	S	SIP3	I-19
R-78Bxx-1.0	1A	4.75	34	1.5,1.8,2.5,3.3,5,6.5,9,12,15	S	SIP3	I-21
R-78Bxx-1.5	1.5A	4.75	18	1.5, 1.8, 2.5, 3.3, 5, 6.5	S	SIP3	I-25
R-78HBxx-0.5	500mA	9	72	3.3,5,6.5,9,12,15	S	SIP3	I-29
R-78HB24-0.3	300mA	36	72	24			
R-78Txx-1.0	1A	7-	42	3.3, 5, 12	S	SMD	I-33
ROF-78E3.3-0.5SMD	500mA	5-	36	3.3	S	SMD	I-37
ROF-78E5.0-0.5SMD	500mA	9-	36	5.0			
R-78E	500mA	7	28	5	S	SIP3	I-41
R-5xxxP/DA	2, 3, 4, 5A	4.75	18	1.2, 1.8, 2.5, 3.3, 5	S	SIP12	I-42
R-6xxxP/D	1.1A, 2A	9	32	1.8, 2.5, 3.3, 5, 9, 12, 18	S	SIP12	I-48
R-7xxxP/D	2, 3, 4A	4.5	28	3.3, 5, 6.5, 9, 12, 15	S	SIP12	I-52

High Voltage Regulators

Series	Output Current	Input Voltages (VDC)		Output Voltages (VDC)	No. of Outputs	Case	Page No.
		min.(1)	max.				
Rxx-B	25mA/50mA	5, 12, 15, 24		40..120, 55..135, 95..210	S	DIP24	I-56

Features

- Efficiency up to 97%, Non isolated, no need for heatsinks
- Pin-out compatible with LM78XX Linears
- Very low profile(L*W*H=11.5*7.5*10.2)
- Wide input range.(4.75V ~ 32V)
- Short circuit protection, Thermal shutdown
- Non standard outputs available as specials
- Low ripple and noise
- UL94V-0 package material
- EMC, Safety Certified
- See Ininline Application Notes for use as an inverter (alternative to LM79xx Linear)

Description

The R-78xx-Series high efficiency switching regulators are ideally suited to replace 78xx linear regulators and are pin compatible. The efficiency of up to 97% means that very little energy is wasted as heat so there is no need for any heat sinks with their additional space and mounting costs. Low ripple and noise figures and short circuit , overload and over-temperature protection round off the specifications of this versatile converter series. This R-78xx-0.5 is fully certified to EN 55022 (Emissions), and EN55024 (Immunity) EMC Standards and for EN-60950-1 Safety.

Selection Guide

Part Number SIP3	Input Range (V)	Output Voltage (V)	Output Current (A)	Efficiency	
				Min. Vin (%)	Max. Vin (%)
R-781.5-0.5	4.75 – 30 ⁽¹⁾	1.5	0.5	73	63
R-781.8-0.5	4.75 – 32	1.8	0.5	82	71
R-782.5-0.5	4.75 – 32	2.5	0.5	87	77
R-783.3-0.5	4.75 ⁽²⁾ – 32	3.3	0.5	91	81
R-785.0-0.5	6.5 – 32	5.0	0.5	94	86
R-786.5-0.5	8.0 – 32	6.5	0.5	95	88
R-789.0-0.5	11 – 32	9.0	0.5	96	92
R-7812-0.5	15 – 32	12	0.5	97	94
R-7815-0.5	18 – 32	15	0.5	97	95

Note 1: 1.5V Output can be unstable with Vin>30VDC

Note 2: Refer to Dynamic Load Stability

Standard Application Circuit

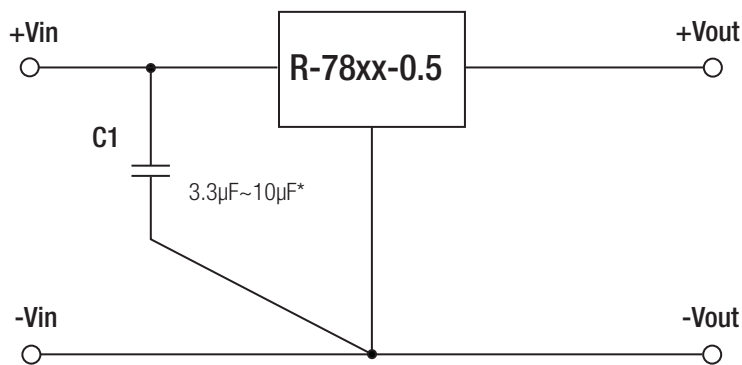

* Input capacitor required if Vin>26VDC (3.3µF) or if the supply is a battery or other low impedance source (4.7µF~10µF)
Capacitor should be electrolytic or MLCC with 1R resistor in series

INNOLINE
DC/DC-Converter
with 3 year Warranty

RECOM

0.5 AMP
SIP3
Single Output



EN-55022 Certified
EN-55024 Certified
EN-60950-1 Certified

R-78-0.5

Derating-Graph (Ambient Temperature)

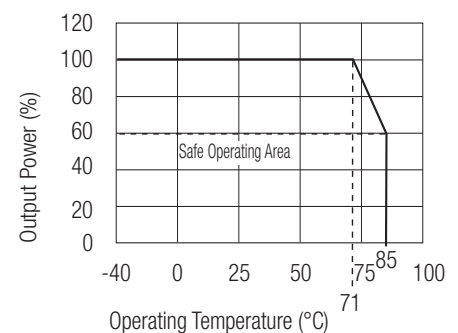

Refer to Application Notes

Specifications (typical at 25°C, 10% minimum load, unless otherwise specified)

Characteristics	Conditions	Min.	Typ.	Max.
Input Voltage Range	1.5V	4.75	30V	34V abs. max.
	1.8V to 15.5V	4.75	32V	34V abs. max.
Output Voltage Range (for customized parts)	All Series	1.25		15.5V
Output Current (see note)	All Series	0*		500mA
Output Current Limit	All Series			2000mA
Short Circuit Input Current (Vin = 24V)	All Series			60mA
Internal Power Dissipation				0.4W
Short Circuit Protection			Continuous, automatic recovery	
Output Voltage Accuracy (At 100% Load)	All Series		±2	±3%
Line Voltage Regulation (Vin = min. to max. at full load)	1.5V to 6.5V		0.2	0.4%
	9V to 15.5V		0.1	0.2%
Load Regulation (10 to 100% full load)	1.5V to 6.5V		0.4	0.6%
	9V to 15.5V		0.25	0.4%
Note: Operation under no load will not damage these devices, however they may not meet all specifications. A minimum load of 6mA is recommended				
Dynamic Load Stability	100% <-> 50% load		±75mV	
	100% <-> 10% load			±100mV
Note: The R-783.3-0.5 requires Vin>5.5V to meet the Dynamic Load Stability Specification.				
Ripple & Noise (without Output Capacitor)	1.5V to 6.5V		20mVp-p	30mVp-p
	9V to 15.5V		30mVp-p	40mVp-p
Ripple & Noise (with Output Capacitor=100µF)	1.5V to 6.5V		15mVp-p	20mVp-p
	9V to 15.5V		25mVp-p	35mVp-p
Temperature Coefficient	-40°C ~ +85°C ambient			0.015%/°C
Max capacitance Load	with normal start-up time, no external components			220µF
	with <1 second start up time + diode protection circuit			6800µF
Switching Frequency		280	330	380kHz
Quiescent Current	Vin = min. to max. at 0% load		5	7mA
Operating Temperature Range		-40°C		+85°C
Operating Case Temperature				+100°C
Storage Temperature Range		-55°C		+125°C
Case Thermal Impedance				70°C / W
Thermal Shutdown	Internal IC junction			+160°C
Case Material			Non-Conductive Black Plastic	
Potting Material			Epoxy (UL94V-0)	
Conducted Emissions (with filter)	EN55022			Class B
Radiated Emissions (with filter)	EN55022			Class B
ESD	EN61000-4-2			Class A
Radiated Immunity	EN61000-4-3			Class A
Fast Transient	EN61000-4-4			Class A
Conducted Immunity	EN61000-4-6			Class A
Magnetic Field Immunity	EN61000-4-8			Class A
Package Weight				1.9g
Packing Quantity				42pcs per Tube
MTBF (+25°C) (+71°C)	} Detailed Information see Application Notes chapter "MTBF"	using MIL-HDBK 217F		21098 x 10 ³ hours
		using MIL-HDBK 217F		4212 x 10 ³ hours
Certifications				
EN General Safety		Report: SPCLVD 1301026-1		EN 60950-1:2006 + A12:2011
EMC		Report: 5A111502E		EN55022, EN61000, EN55024

Characteristics

Efficiency

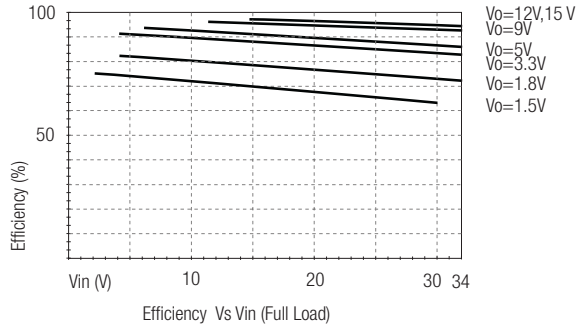

Ripple

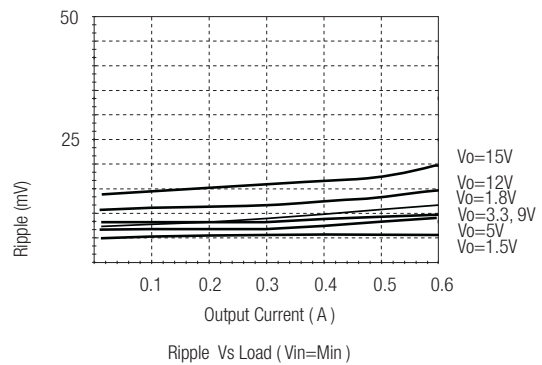
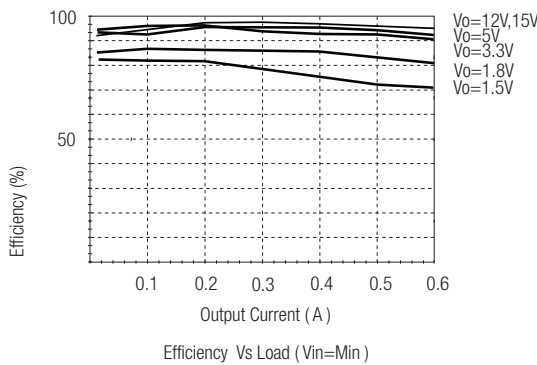
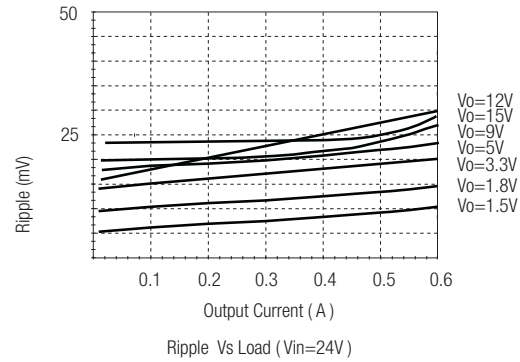
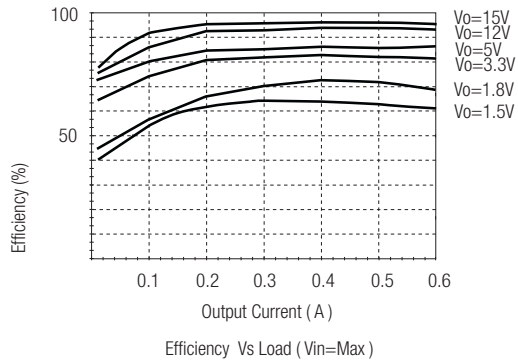
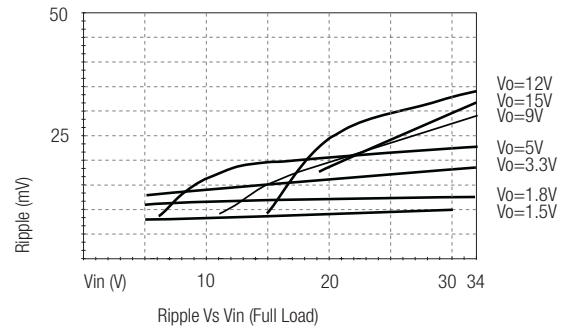

Optional Diode Protection Circuit

Optional Protection 1:

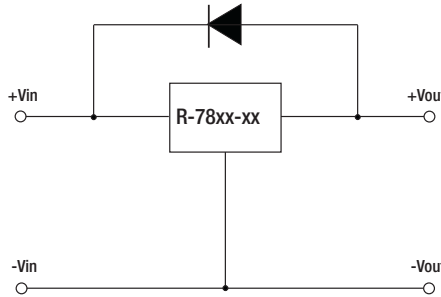

Add a blocking diode to Vout if current can flow backwards into the output, as this can damage the converter when it is powered down.

The diode can either be fitted across the device if the source is low impedance or fitted in series with the output (recommended).

Optional Protection 2:

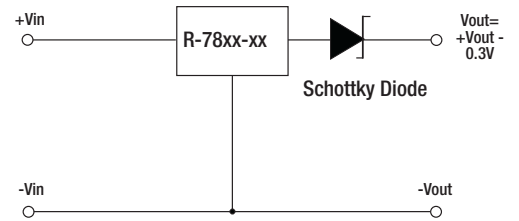

Application example:
Driving a high capacitive load

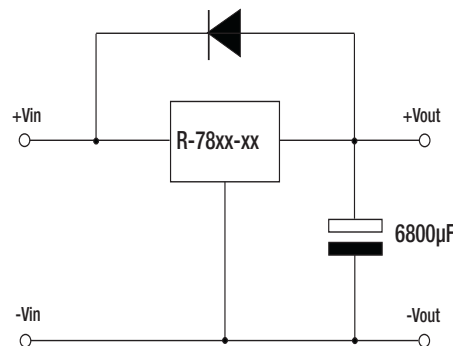

Application Examples

High efficiency, isolated, dual unregulated outputs

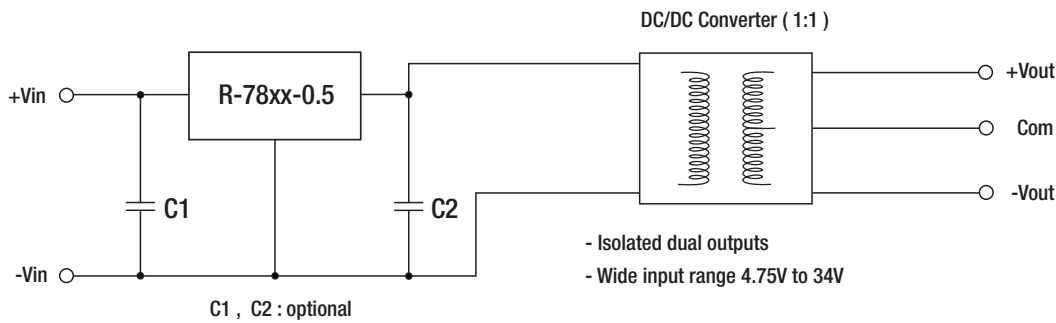

R-78-0.5

Isolated (up to 6KV), wide Input range regulated output

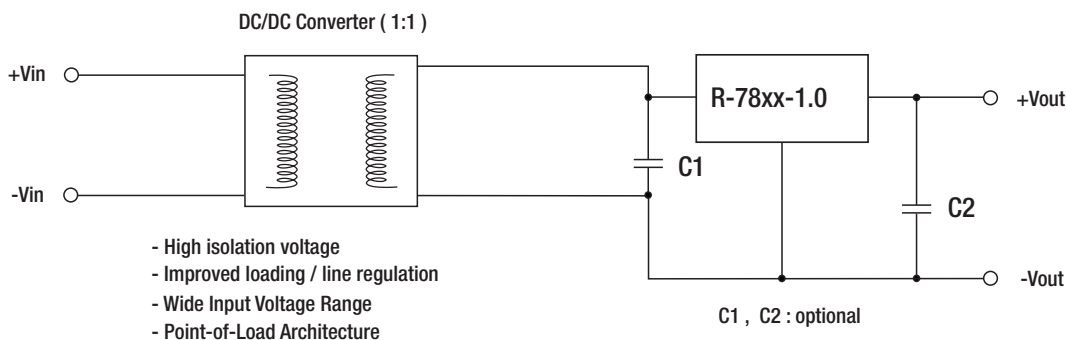

Package Style and Pinning (mm)

SIP3 PIN Package

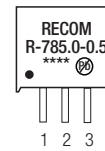
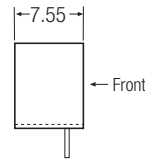
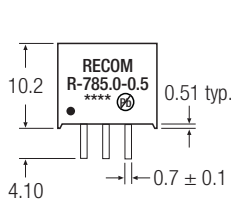

Recommended Footprint Details

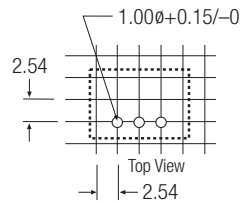
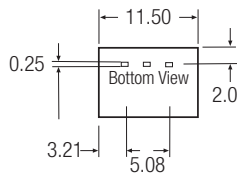

Pin Connections

Pin #	Connection
1	+Vin
2	GND
3	+Vout

xx.x ±0.5mm
xx.xx ±0.25mm

Features

- Replacement for R-78Axx-0.5SMD series
- RoHS 6/6 Conform (100% Lead Free)
- Efficiency up to 97%, Non isolated, no need for heatsinks
- High Reflow Temperature SMD Package
- Adjustable Output Voltage
- Wide input range.(4.75V ~ 32V)
- Short circuit protection, Thermal shutdown
- Remote On/Off Control
- UL94V-0 Package Material
- Very Low Shutdown Current
- See InnoLine Application Notes for use as an inverter (alternative to LM79xx Linear)

Description

The R-78Axx-0.5SMD series are manufactured without lead and meet the requirements for RoHS 6/6 as well as the increased reflow soldering temperatures associated with vapour phase soldering, making these high efficiency switching regulators ideally suited to modern pick-and-place mass production. The efficiency of up to 97% means that very little energy is wasted as heat. The additional features of remote on/off control and adjustable output voltages will find many uses in the battery-powered, industrial, medical and automotive markets.

Selection Guide

Part Number SMD	Input Range (V)	Output Voltage (V)	Adjust Range (V)	Output Current (A)	Efficiency	
					Min. Vin (%)	Max. Vin (%)
R-78AA1.5-0.5SMD	4.75 – 30	1.5	fixed	0.5	73	63
R-78AA1.8-0.5SMD	4.75 – 32	1.8	1.5~3.0	0.5	82	71
R-78AA2.5-0.5SMD	4.75 – 32	2.5	1.5~3.0	0.5	87	77
R-78AA3.3-0.5SMD	4.75 – 32	3.3	3.0~5.5	0.5	91	81
R-78AA5.0-0.5SMD	6.5 – 32	5.0	3.0~8.0	0.5	94	86
R-78AA6.5-0.5SMD	8.0 – 32	6.5	3.3~11.0	0.5	95	88
R-78AA9.0-0.5SMD	11 – 32	9.0	4.5~12.6	0.5	96	92
R-78AA12-0.5SMD	15 – 32	12	4.5~12.6	0.5	97	94
R-78AA15-0.5SMD	18 – 32	15	fixed	0.5	97	95

Note 1: 1.5V Output can be unstable with Vin > 30VDC

* add suffix -R for tape&reel packing e.g. R-78AA5.0-0.5-R. For more details see Application Notes.

Standard Application Circuit

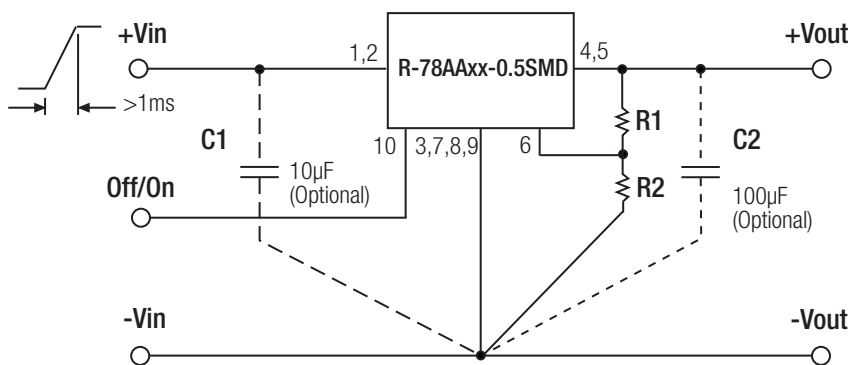

To protect the converter from high inrush currents, use soft start Vin and C1=10µF
Output capacitor C2 recommended if load is very dynamic

INNOLINE
DC/DC-Converter
with 3 year Warranty

RECOM

0.5 AMP
SMD
Single Output

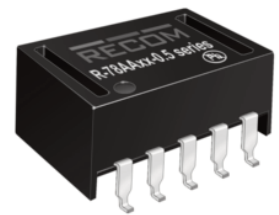

EN-60950-1 Certified

R-78AA-0.5

Derating-Graph (Ambient Temperature)

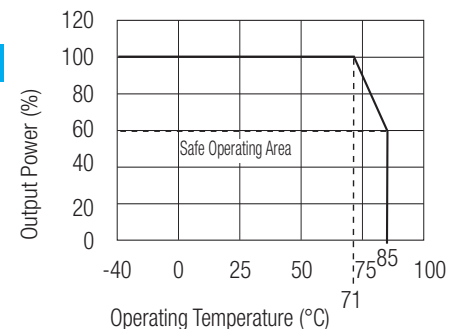

Refer to Application Notes

Specifications (typical at 25°C, 10% minimum load, unless otherwise specified)

Characteristics	Conditions	Min.	Typ.	Max.
Input Voltage Range	See Table	4.75V	32V	34V abs. max.
Output Voltage Range	See Table	1.5V		15V
Output Current (see Note)	All Series	0mA*		500mA
Output Current Limit	All Series			2000mA
Short Circuit Input Current	V _{in} = 24V		60mA	100mA
Internal Power Dissipation				0.4W
Short Circuit Protection			Continuous, automatic recovery	
Output Voltage Accuracy	100% Load		±2%	±3%
Adjustable Voltage Range	See Table 1			±50%
Line Voltage Regulation (V _{in} = min. to max. at full load)	1.5V to 6.5V		0.2%	0.4%
	9V to 15V		0.1%	0.2%
Load Regulation (10 to 100% full load)	1.5V to 6.5V		0.7%	1.0%
	9V to 15V		0.25%	0.4%
Dynamic Load Stability with 100µF Output capacitor	100% <-> 50% load		±75V	±100mV
	100% <-> 10% load		±100mV	
Ripple & Noise (without Output Capacitor)	1.5V to 6.5V		20mVp-p	30mVp-p
	9V to 15.5V		30mVp-p	40mVp-p
Temperature Coefficient	-40°C ~ +85°C ambient			0.015%/°C
Max capacitance Load	with normal start-up time, no external components			220µF
	with <1 second start up time + diode protection circuit			6800µF
Switching Frequency		280kHz	330kHz	380kHz
Quiescent Current	V _{in} = min. to max. at 0% load		5mA	7mA
ON/OFF Remote Control Pin Drive Current	ON: Open or 1.6V<V _r <5V			
	OFF: GND or 0<V _r <1.6V		I _r =1.8µA typ	
Converter Input Current (valid for V _r < 1.6V)			20µA	30µA
Remote On/Off Threshold Voltage (V _r rising)		2.4V	2.6V	2.8V
Remote On/Off Voltage Hysteresis			250mV	
Operating Temperature Range (with derating)		-40°C		+85°C
Switch On/Off Time	(using Remote On/Off Control)			50ms
Operating Case Temperature				+100°C
Storage Temperature Range		-55°C		+125°C
Case Thermal Impedance				70°C / W
Thermal Shutdown	Internal IC junction			+160°C
Case Material			Non-Conductive Black Plastic	
Potting Material			Epoxy (UL94V-0)	
EMC	Conducted Emissions (with filter)	EN55022		Class B
	Radiated Emissions (with filter)	EN55022		Class B
	ESD	EN61000-4-2		Class A
	Radiated Immunity	EN61000-4-3		Class A
	Fast Transient	EN61000-4-4		Class A
	Conducted Immunity	EN61000-4-6		Class A
	Magnetic Field Immunity	EN61000-4-8		Class A
Safety Certification	Report: SPCLVD 1301026-1		EN 60950-1:2006 + A12:2011	
Package Weight				2.7g
Packing Quantity				33pcs per Tube
				250pcs per Reel
MTBF (+25°C) (+71°C)	} Detailed Information see Application Notes chapter "MTBF"	using MIL-HDBK 217F	21098~29253 x 10 ³ hours	
			4214-7365 x 10 ³ hours	

*Note: Operation under no load will not damage these devices, however they may not meet all specifications. A minimum load of 6mA is recommended

Characteristics

Efficiency

Ripple

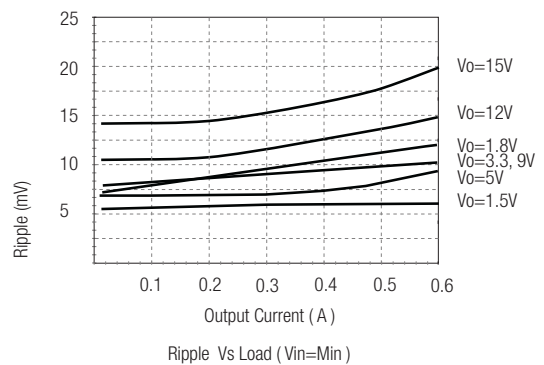
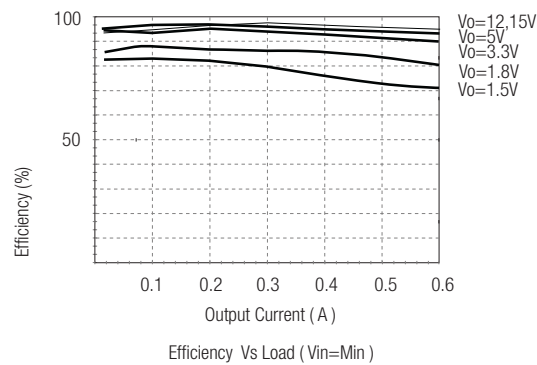
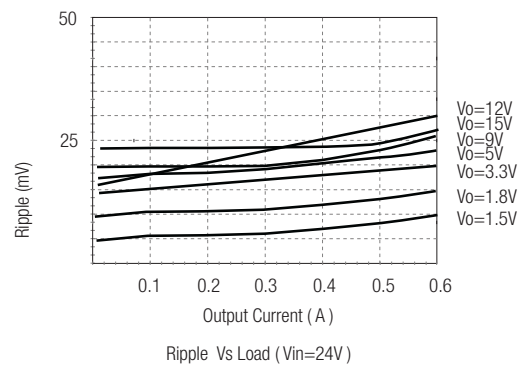
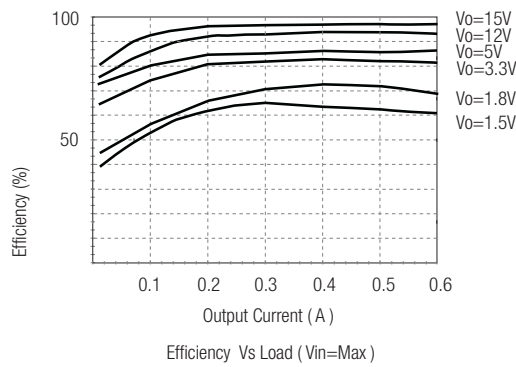
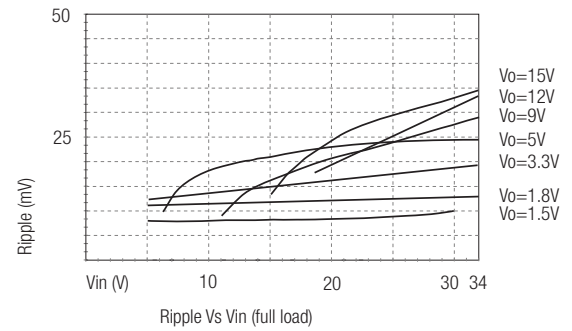
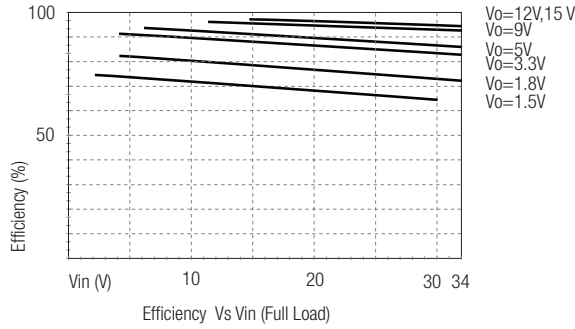

Application Examples

Flash Memory Program Voltage Switcher

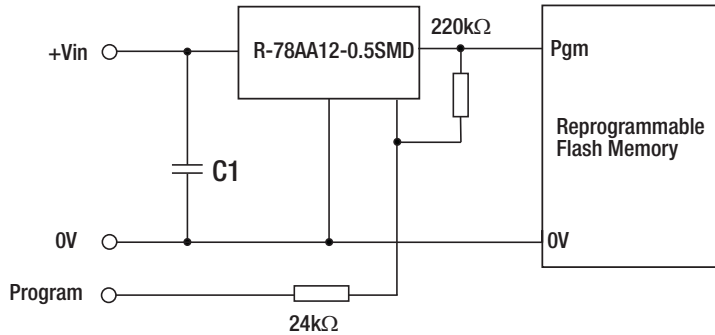

"Program" = 0V, Pgm Pin = +5V
 "Program" = high, Pgm Pin = +12,6V

DC/DC Converter (1:1)

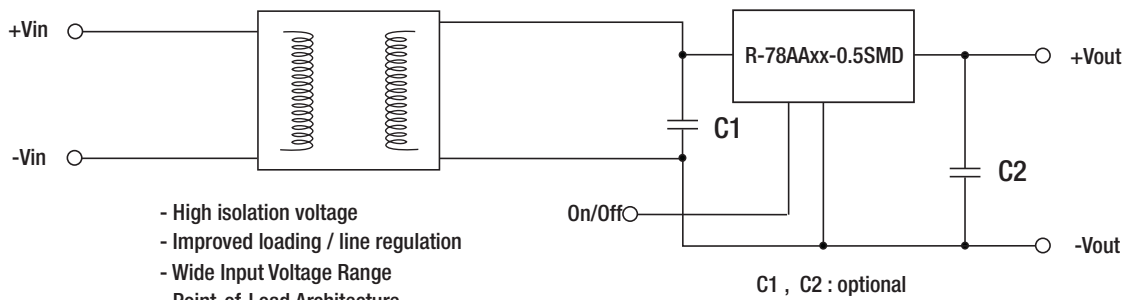

- High isolation voltage
- Improved loading / line regulation
- Wide Input Voltage Range
- Point-of-Load Architecture
- Remote On/Off Control

C1 , C2 : optional

Optional Protection Circuit

Optional Protection 1:

Add a blocking diode to Vout if current can flow backwards into the output, as this can damage the converter when it is powered down.

The diode can either be fitted across the device if the source is low impedance or fitted in series with the output (recommended).

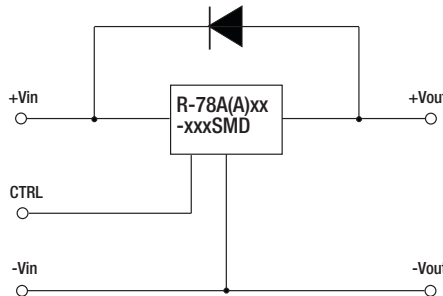

Optional Protection 2:

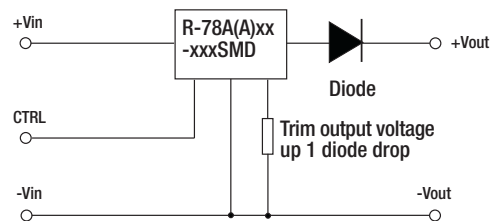

Application example:
Driving a high capacitive load

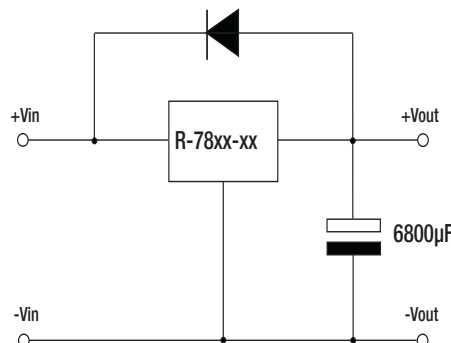
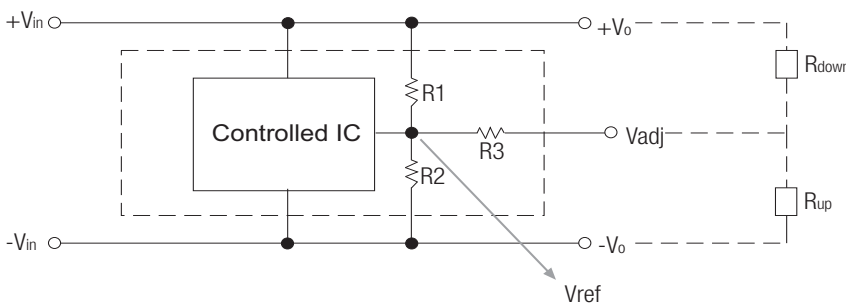

Table 1: Adjustment Resistor Values

	R1	R2	R3	Vref(V)
1.8V	10KΩ	21KΩ	5.6KΩ	1.23
2.5V	22KΩ	21KΩ	5.6KΩ	1.23
3.3V	16.9KΩ	10KΩ	5.6KΩ	1.23
5.0V	30.9KΩ	10KΩ	10KΩ	1.23
6.5V	43KΩ	10KΩ	10KΩ	1.23
9V	63.4KΩ	10KΩ	22.1KΩ	1.23
12V	88.7KΩ	10KΩ	22.1KΩ	1.23



Trim Down $R_{down} = \frac{R_2(R_1+R_3) \times (V_{ref} - V_o) + V_{ref} \times R_1R_3}{R_2V_o - V_{ref} (R_1 + R_2)}$

Trim up $R_{up} = \frac{R_2R_3 (V_{ref} - V_o) + V_{ref} R_1 (R_2 + R_3)}{R_2 (V_o - V_{ref}) - V_{ref} R_1}$

Package Style and Pinning (mm)

SMD 10Pin Package

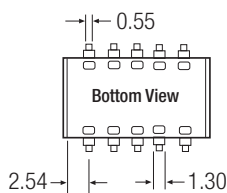
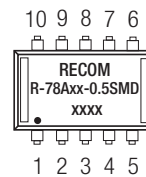
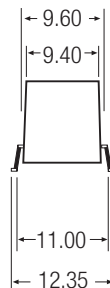
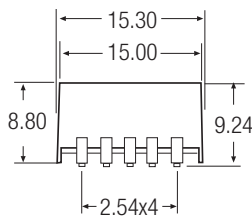

Recommended Footprint Details

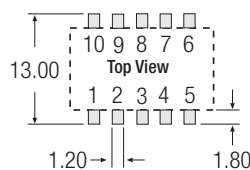

Pin Connections

Pin #	Connection
1,2	+Vin
3,7,8,9	GND
4,5	+Vout
6	V adj
10	Remote On/Off
xx.x	±0.5mm
xx.xx	±0.25mm

The product information and specifications are subject to change without prior notice. All products are designed for non-safety critical commercial and industrial applications. The Buyer agrees to implement safeguards that anticipate the consequences of any failures that might cause harm, loss of life and/or damage property.

Features

- Efficiency up to 94%, no need for heatsinks!
- Pin-out compatible with LM78XX Linear Regs.
- Low profile (L*W*H=11.5*7.5*10.2mm)
- Wide input range (4.75V ~ 18V)
- Short circuit protection, thermal shutdown
- Non standard outputs available as specials
- Low ripple and noise

Description

The R-78xx-1.0 series switching regulators are ideally suited to replace 1 Amp 78xx linear regulators and are pin compatible. Efficiencies of up to 97% means that very little energy is wasted as heat so there is no need for any heat sinks with their additional space and mounting costs.

Selection Guide

Part Number SIP3	Input Range (V)	Output Voltage (V)	Output Current (A)	Efficiency	
				Min. Vin (%)	Max. Vin (%)
R-781.8-1.0	4.75 – 18	1.8	1.0	82	76
R-782.5-1.0	4.75 – 18	2.5	1.0	87	81
R-783.3-1.0	4.75 – 18	3.3	1.0	90	84
R-785.0-1.0	6.5 – 18	5.0	1.0	94	89

Specifications (typical at 25°C, 10% minimum load, unless otherwise specified)

Characteristics	Conditions	Min.	Typ.	Max.
Input Voltage Range	All Series	4.75V		18V
Output Voltage Range	All Series	1.5V		5.5V
Output Current	All Series	0mA*		1000mA
Output Current Limit	All Series			3000mA
Short Circuit Input Current (Vin =12V)	All Series			100mA
Internal Power Dissipation				0.4W
Short Circuit Protection			Continuous, automatic recovery	
Output Voltage Accuracy (At 100% Load)	All Series		±2%	±3%
Line Regulation (100% Load, Vin max.)	All Series		0.2%	0.4%
Load Regulation (10 to 100% full load)	All Series		0.4%	0.6%
Dynamic Load Stability	100% <-> 50% load		±85mV	±100mV
Ripple & Noise (20Mhz BW)	All Series		20mVp-p	30mVp-p
Temperature Coefficient	-40°C ~ +85°C ambient			0.015%/°C
Max capacitance Load	with normal start-up time, no external components			470µF
	with <1 second start up time + diode protection circuit			6800µF
Switching Frequency		280kHz	350kHz	430kHz
Quiescent Current	Vin = min. to max. at 0% load		5mA	7mA
Operating Temperature Range				-40°C to +85°C
Operating Case Temperature (with derating)				+100°C
Storage Temperature Range				-55°C to +125°C
Case Thermal Impedance				70°C/W
Thermal Shutdown	Internal IC junction			+160°C
Case Material				Non-Conductive Black Plastic
Potting Material				Epoxy (JL94V-0)
Conducted Emissions (with filter)	EN55022			Class B
Radiated Emissions (with filter)	EN55022			Class B
ESD	EN61000-4-2			Class A
Radiated Immunity	EN61000-4-3			Class A
Fast Transient	EN61000-4-4			Class A
Conducted Immunity	EN61000-4-6			Class A
Magnetic Field Immunity	EN61000-4-8			Class A
Certifications				
General Safety	Report: SPCLVD 1301026-1			EN 60950-1:2006 + A12:2011
EMC	Report: 5A111502E			EN 55022, EN55024, EN61000
Package Weight				1.9g
Packing Quantity				42 pcs per Tube
MTBF (+25°C)	} Detailed Information see Application Notes chapter "MTBF"	using MIL-HDBK 217F		13338 x 10 ³ hours.
(+71°C)		using MIL-HDBK 217F		3880 x 10 ³ hours.

R-78-1.0

INNOLINE
DC/DC-Converter
with 3 year Warranty

RECOM

1.0 AMP
SIP3
Single Output



EN-55022 Certified
EN-55024 Certified
EN-60950-1 Certified

R-78-1.0

Derating-Graph (Ambient Temperature)

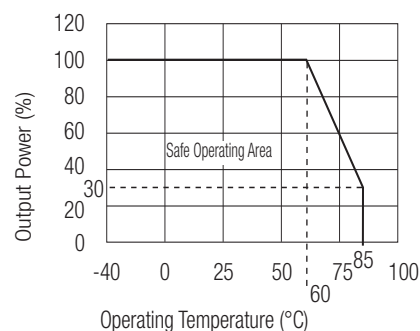

Refer to Application Notes

Characteristics

Efficiency

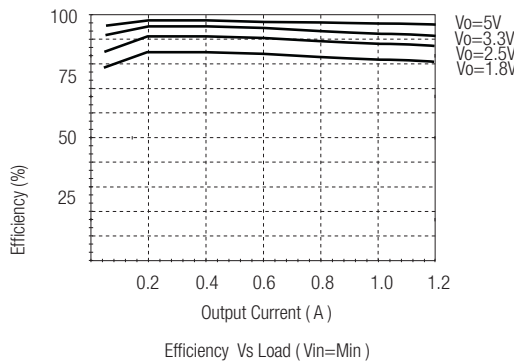
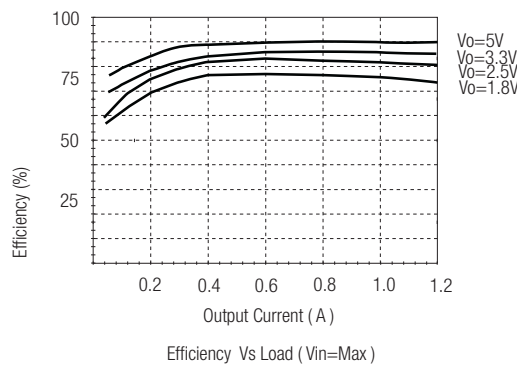
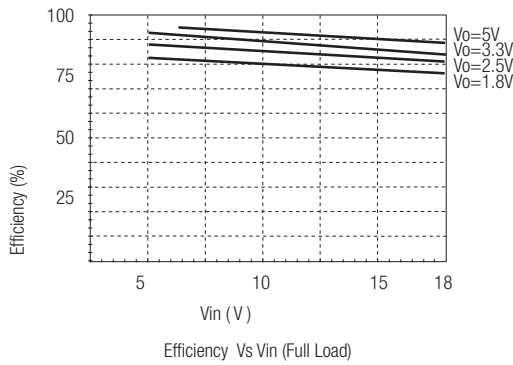

Ripple

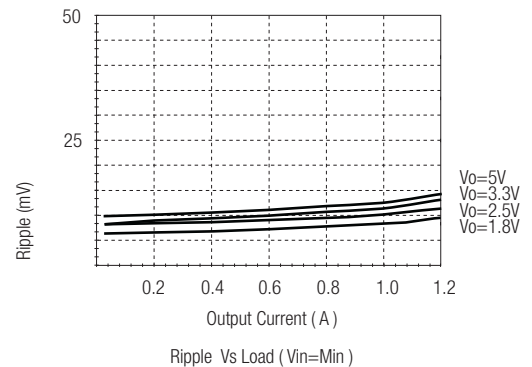
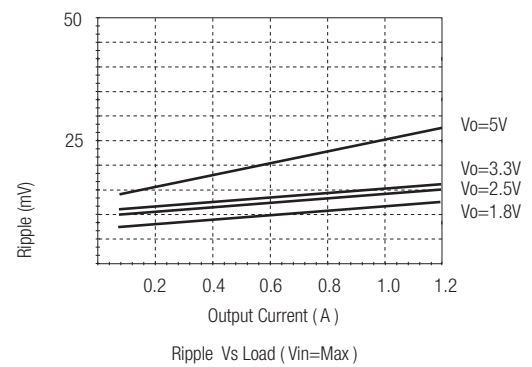
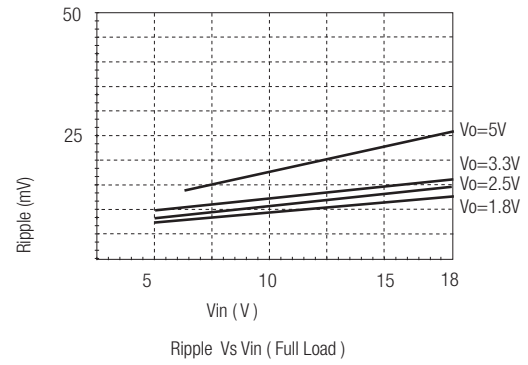

*Note: Operation under no load will not damage these devices, however they may not meet all specifications. A minimum load of 10mA is recommended

Optional Protection Circuit

Optional Protection 1:

Add a blocking diode to Vout if current can flow backwards into the output, as this can damage the converter when it is powered down.

The diode can either be fitted across the device if the source is low impedance or fitted in series with the output (recommended).

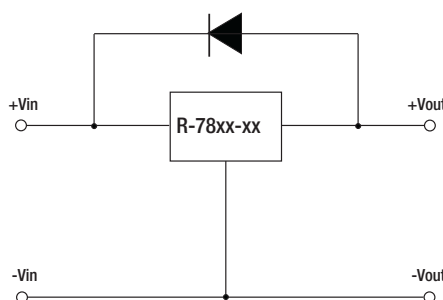

Optional Protection 2:

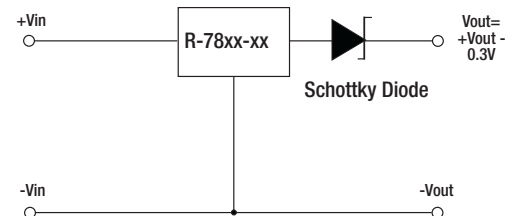

Application Examples

High efficiency, isolated, dual regulated outputs

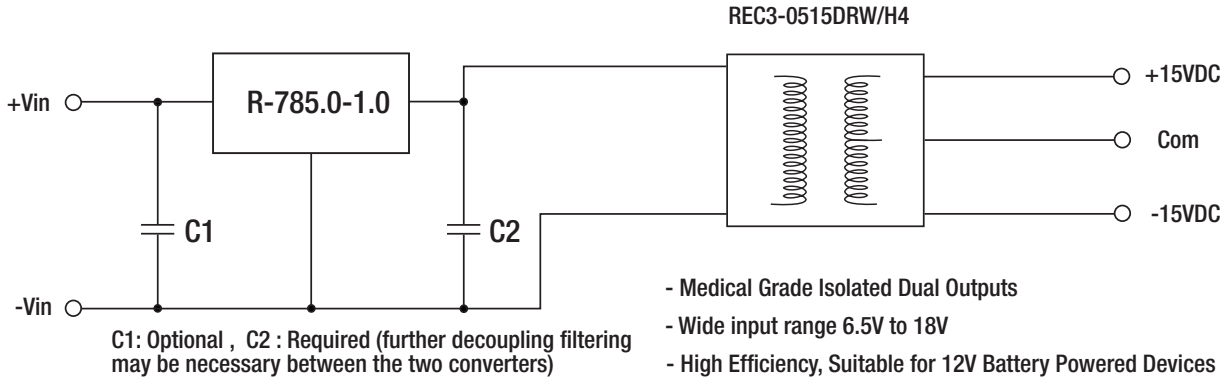

Isolated (up to 6KV), wide Input range regulated output

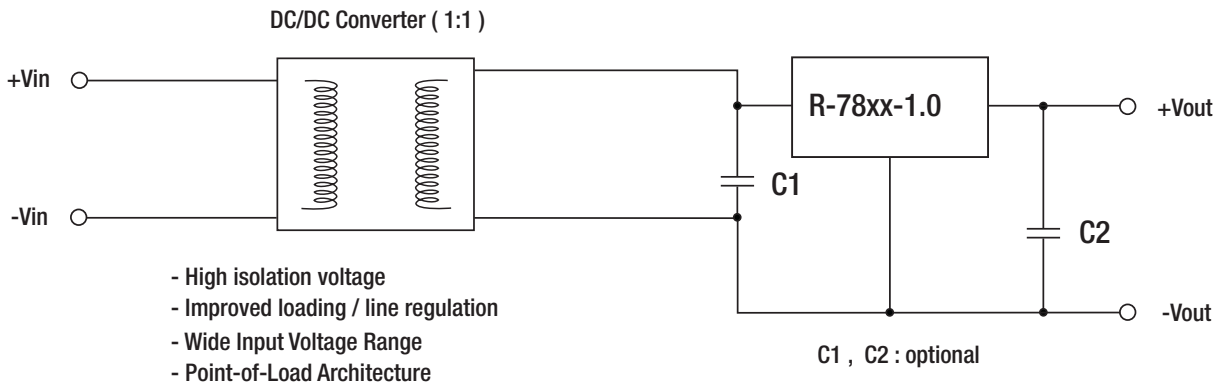

R-78-1.0

Package Style and Pinning (mm)

SIP3 PIN Package

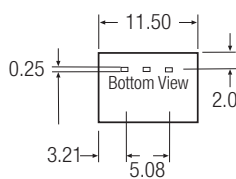
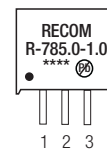
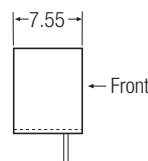
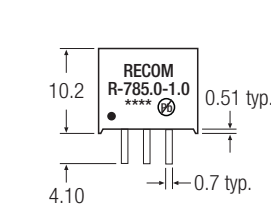

Recommended Footprint Details

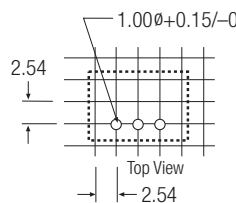

Pin Connections

Pin #	Connection
1	+Vin
2	GND
3	+Vout

xx.x ±0.5mm
xx.xx ±0.25mm

Features

- Replacement for R-78Axx-1.0SMD series
- RoHS 6/6 Conform (100% Lead Free)
- High Reflow Temperature SMD Package
- Adjustable Output Voltage
- Short circuit protection, Thermal shutdown
- Remote On/Off Control
- Very Low Shutdown Current

Description

The R-78Axx-1.0SMD series are manufactured without lead and meet the requirements for RoHS 6/6 as well as the increased reflow soldering temperatures associated with vapour phase soldering, making these high efficiency switching regulators ideally suited to modern pick-and-place mass production. The efficiency of up to 94% means that very little energy is wasted as heat. The additional features of remote on/off control and adjustable output voltages will find many uses in the battery-powered, industrial, medical and automotive markets.

Selection Guide

Part Number SMD	Input Range (V)	Output Voltage (V)	Adjust Range (V)	Output Current (A)	Efficiency	
					Min. Vin (%)	Max. Vin (%)
R-78AA1.5-1.0SMD	4.75 – 18	1.5	fixed	1.0	77	73
R-78AA1.8-1.0SMD	4.75 – 18	1.8	1.5~3.0	1.0	82	76
R-78AA2.5-1.0SMD	4.75 – 18	2.5	1.5~3.0	1.0	87	81
R-78AA3.3-1.0SMD	4.75 – 18	3.3	3.0~5.5	1.0	90	84
R-78AA5.0-1.0SMD	6.5 – 18	5.0	3.0~5.5	1.0	94	89

Specifications (typical at 25°C, 10% minimum load, unless otherwise specified)

Characteristics	Conditions	Min.	Typ.	Max.
Input Voltage Range	See Table	4.75V		18.0V
Output Voltage Range	See Table	1.5V		5.5V
Output Current	All Series	0mA*		1000mA
Output Current Limit	All Series			5500mA
Short Circuit Input Current	Vin = 12V			120mA
Internal Power Dissipation				0.4W
Short Circuit Protection		Continuous, automatic recovery		
Output Voltage Accuracy	100% Load		±2%	±3%
Adjustable Voltage Range	See Table 1			±50%
Line Voltage Regulation (Vin = min to max at full load)			0.2%	0.4%
Load Regulation (10% to 100% full load)			0.7%	1.0%
Dynamic Load Stability	100% <-> 50% load, 25mA/µs		±85mV	±100mV
Ripple & Noise (20MHz BW)			20mVp-p	30mVp-p
Temperature Coefficient	-40°C ~ +85°C ambient			0.015%/°C
Max capacitance Load	with normal start-up time, no external components			470µF
	with <1 second start up time + diode protection circuit			6800µF
Switching Frequency		335kHz	385kHz	435kHz
Quiescent Current	Vin = min. to max. at 0% load		5mA	7mA
ON/OFF Remote Control Pin Drive Current	ON: Open or 1.6V < Vr < 5V OFF: GND or 0 < Vr < 1.6V			I _r = 1.8µA typ
Converter Input Current (valid for Vr < 1.6V)			20µA	35µA
Remote On/Off Threshold Voltage (Vr rising)		2.4V	2.6V	2.8V
Remote On/Off Voltage Hysteresis			250mV	
Operating Temperature Range		-40°C		+85°C
Switch On/Off Time	(using Remote On/Off Control)			50ms
Operating Case Temperature				+100°C
Storage Temperature Range		-55°C		+125°C
Case Thermal Impedance				70°C / W
Thermal Shutdown	Internal IC junction			+160°C

continued on next page

INNOLINE
DC/DC-Converter
with 3 year Warranty

RECOM

1.0 AMP SMD Single Output

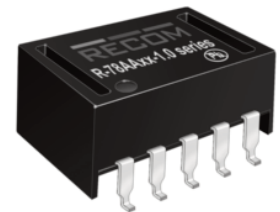

EN-60950-1 Certified

R-78AA-1.0

Derating-Graph (Ambient Temperature)

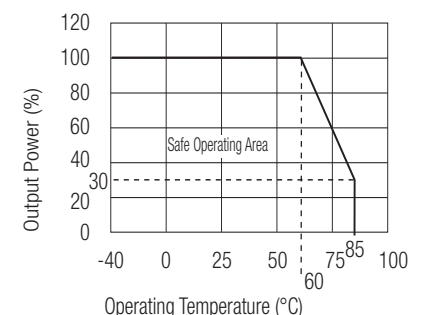

Refer to Application Notes

Specifications (typical at 25°C, 10% minimum load, unless otherwise specified)

Case Material	Non-Conductive Black Plastic		
Potting Material	Epoxy (UL94V-0)		
EMC	Conducted Emissions (with filter)	EN55022	Class B
	Radiated Emissions (with filter)	EN55022	Class B
	ESD	EN61000-4-2	Class A
	Radiated Immunity	EN61000-4-3	Class A
	Fast Transient	EN61000-4-4	Class A
	Conducted Immunity	EN61000-4-6	Class A
	Magnetic Field Immunity	EN61000-4-8	Class A
Safety Certification	Report: SPCLVD 1301026-1	EN-60950-1:2006 + A12:2011	
Package Weight			1.7g
Packing Quantity			33 pcs per Tube
			250 pcs per Reel
MTBF (+25°C)	} Detailed Information see Application Notes chapter "MTBF"	13338~21070 x 10 ³ hours	
		using MIL-HDBK 217F	3880~6769 x 10 ³ hours
(+71°C)			

*Note: Operation under no load will not damage these devices, however they may not meet all specifications. A minimum load of 10mA is recommended

Characteristics

Efficiency

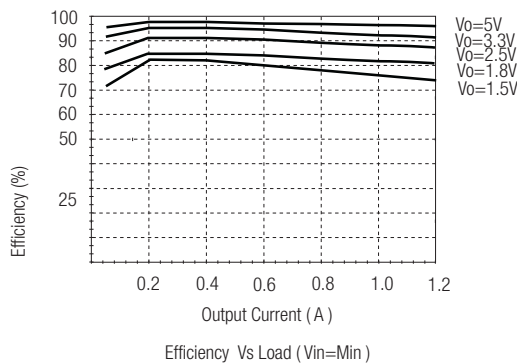
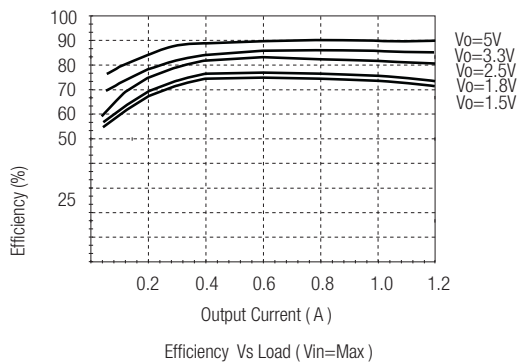
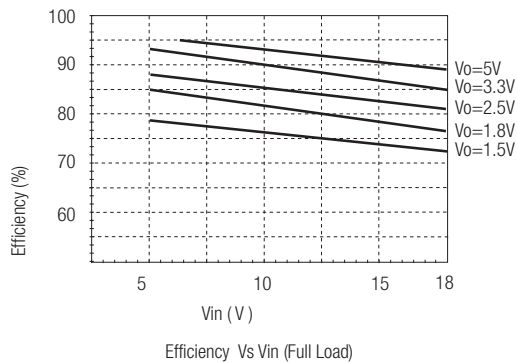

Ripple

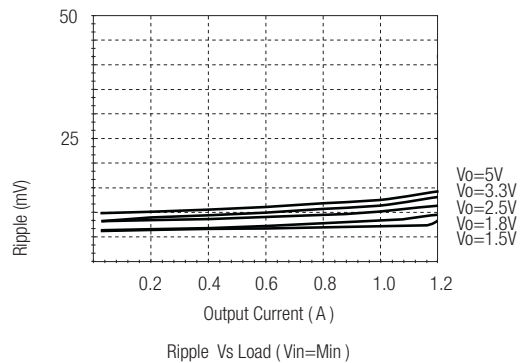
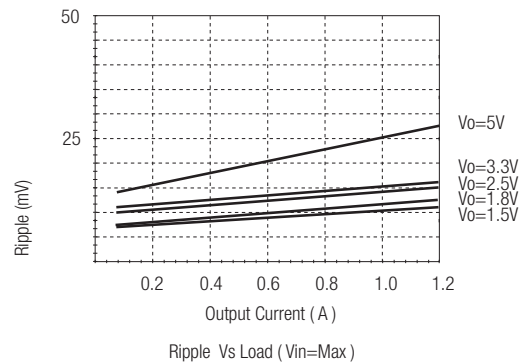
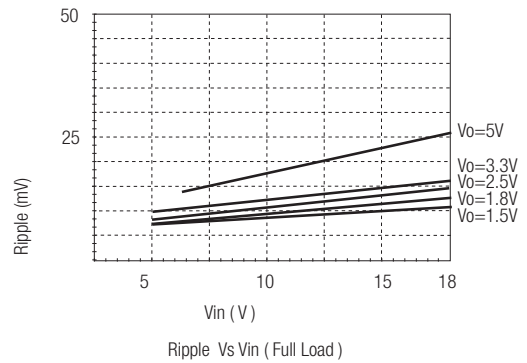

Standard Application Circuit

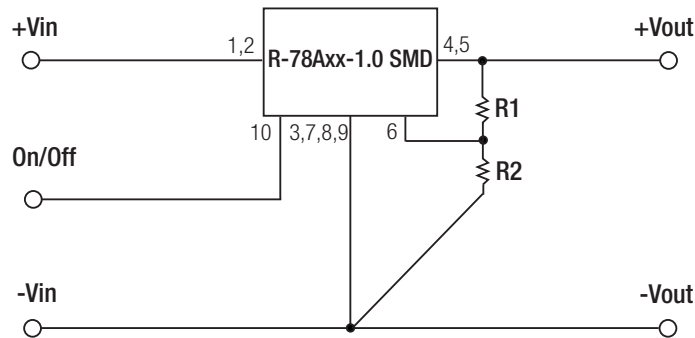

Application Examples

3.3V/5V Selectable 1A Power Supply

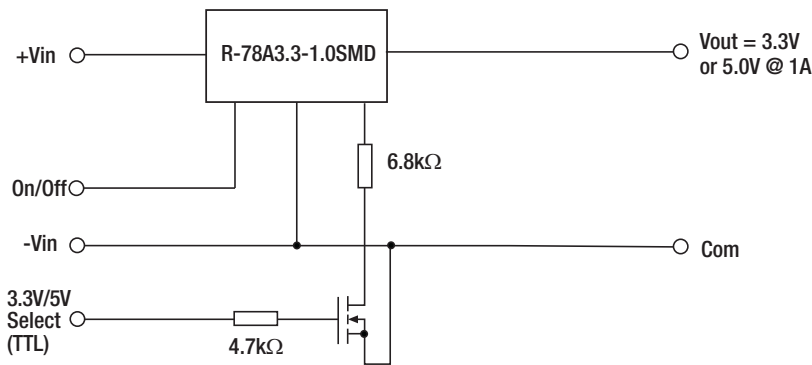

Optional Protection Circuit

Optional Protection 1:

Add a blocking diode to Vout if current can flow backwards into the output, as this can damage the converter when it is powered down.

The diode can either be fitted across the device if the source is low impedance or fitted in series with the output (recommended).

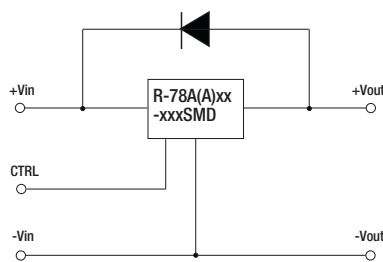

Optional Protection 2:

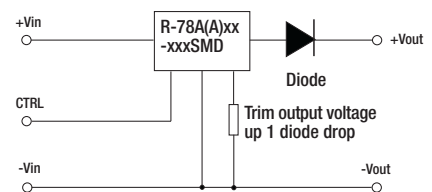

Application example:
Driving a high capacitive load

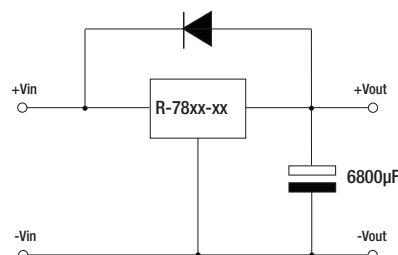
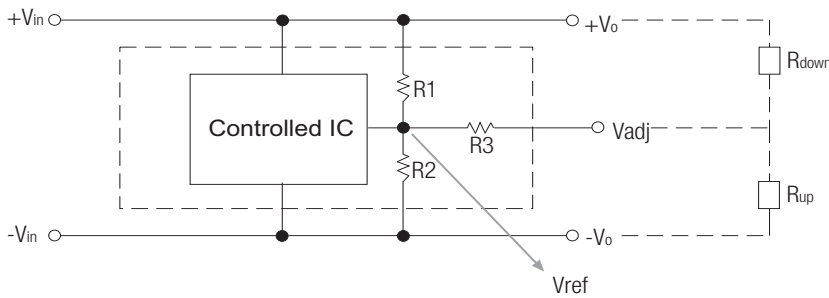

Table 1: Adjustment Resistor Values

	R1	R2	R3	Vref(V)
1.8V	10KΩ	21KΩ	5.6KΩ	1.23
2.5V	22KΩ	21KΩ	5.6KΩ	1.23
3.3V	16.9KΩ	10KΩ	5.6KΩ	1.23
5.0V	30.9KΩ	10KΩ	10KΩ	1.23



Trim Down $R_{down} = \frac{R_2(R_1+R_3) \times (V_{ref} - V_o) + V_{ref} \times R_1R_3}{R_2V_o - V_{ref} (R_1 + R_2)}$

Trim up $R_{up} = \frac{R_2R_3 (V_{ref} - V_o) + V_{ref} R_1 (R_2 + R_3)}{R_2 (V_o - V_{ref}) - V_{ref} R_1}$

R-78AA-1.0

Package Style and Pinning (mm)

SMD 10Pin Package

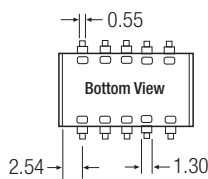
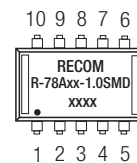
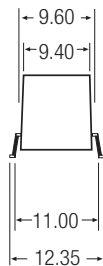
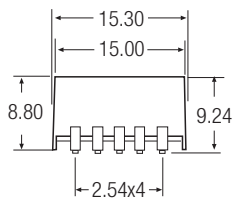

Recommended Footprint Details

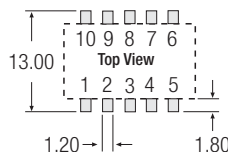

Pin Connections

Pin #	Connection
1,2	+Vin
3,7,8,9	GND
4,5	+Vout
6	V adj
10	Remote On/Off
xx.x	±0.5mm
xx.xx	±0.25mm

Features

- Efficiency up to 96%, no need for heatsinks!
- Pin-out compatible with LM78XX Linear Regs.
- Low profile (L*W*H=11.6*8.5*10.4mm)
- Wide input range (5V ~ 42V)
- Short circuit protection, thermal shutdown
- Non standard outputs available as specials
- Low ripple and noise
- See InnoLine App Notes for use as a positive-to-negative inverter (alternative to 79xx regulator)

Description

The R-78Cxx-1.0 series switching regulators are ideally suited to replace 1 Amp 78xx linear regulators and are pin compatible. Efficiencies of up to 96% means that very little energy is wasted as heat and the high input voltage is a useful feature.

Selection Guide

Part Number	Input Range (V)	Output Voltage (V)	Output Current (A)	Efficiency	
				Min. Vin (%)	Max. Vin (%)
R-78C1.8-1.0	5 – 42	1.8	1.0	80	71
R-78C3.3-1.0	7 – 42	3.3	1.0	89	79
R-78C5.0-1.0	8 – 42	5	1.0	93	85
R-78C9.0-1.0	12 – 42	9	1.0	95	90
R-78C12-1.0	15 – 42	12	1.0	96	92
R-78C15-1.0	18 – 42	15	1.0	96	94

Specifications (typical at 25°C, 10% minimum load, unless otherwise specified)

Characteristics	Conditions	Min.	Typ.	Max.
Input Voltage Range	All Series	Vout+3V		42V
Output Voltage Range	All Series	1.8V		15V
Output Current	All Series	0mA*		1000mA
Short Circuit Input Current (Vin =24V)	All Series		65mA	
No Load Input Current			1mA	
Short Circuit Protection			Continuous, automatic recovery	
Output Voltage Accuracy (At 100% Load)	All Series		±2%	±3%
Line Regulation (100% Load, Vin max.)	All Series		0.2%	
Load Regulation (10 to 100% full load)	All Series		0.4%	
Dynamic Load Stability	100% <-> 50% load			±75mV
	100% <-> 10% load			±200mV
Ripple & Noise (20Mhz BW Limited)	Vin = 24V, Vout =1.8V-15V		75mVp-p	100mVp-p
With 10µF MLCC output capacitor	Full Load		30mVp-p	
Temperature Coefficient	-40°C ~ +85°C ambient			0.015%/°C
Max capacitance Load	with normal start-up time, no external components			470µF
	with <1 second start up time + diode protection circuit			6800µF
Switching Frequency		280kHz	350kHz	420kHz
Operating Temperature Range		-40°C		+85°C
Maximum Case Temperature				+100°C
Storage Temperature Range		-55°C		+125°C
Case Thermal Impedance				70°C/W
Conducted Emissions (with filter)	EN55022			Class B
Radiated Emissions (with filter)	EN55022			Class B
ESD	EN61000-4-2			Class A
Radiated Immunity	EN61000-4-3			Class A

continued on next page

INNOLINE
DC/DC-Converter
with 3 year Warranty

RECOM

1.0 AMP
SIP3
Single Output



EN-60950-1 Certified

R-78C-1.0

Derating-Graph (Ambient Temperature)

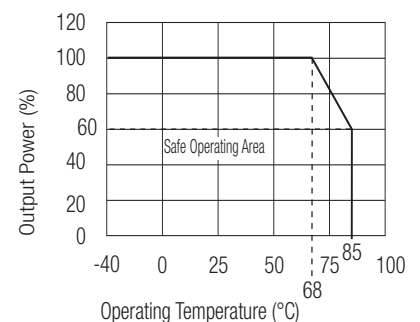

Refer to Application Notes

Specifications (typical at 25°C, 10% minimum load, unless otherwise specified)

Fast Transient	EN61000-4-4	Class A
Conducted Immunity	EN61000-4-6	Class A
Magnetic Field Immunity	EN61000-4-8	Class A
Package Weight		2g
Packing Quantity		42 pcs per Tube
Case Material		Non-Conductive Black Plastic
Potting Material		Epoxy (UL94V-0)
Certifications		
General Safety	Report: SPCLVD 1301026-1	EN 60950-1:2006 + A12:2011
Standby Power		EN62301:2005
MTBF (+25°C)	using MIL-HDBK 217F	8600 x 10 ³ hours.
(+68°C)	using MIL-HDBK 217F	3880 x 10 ³ hours.

Note:

No load operation will not damage these devices, however they may not meet all specifications. A minimum load of 10mA is recommended.

Application Examples

High efficiency regulated outputs

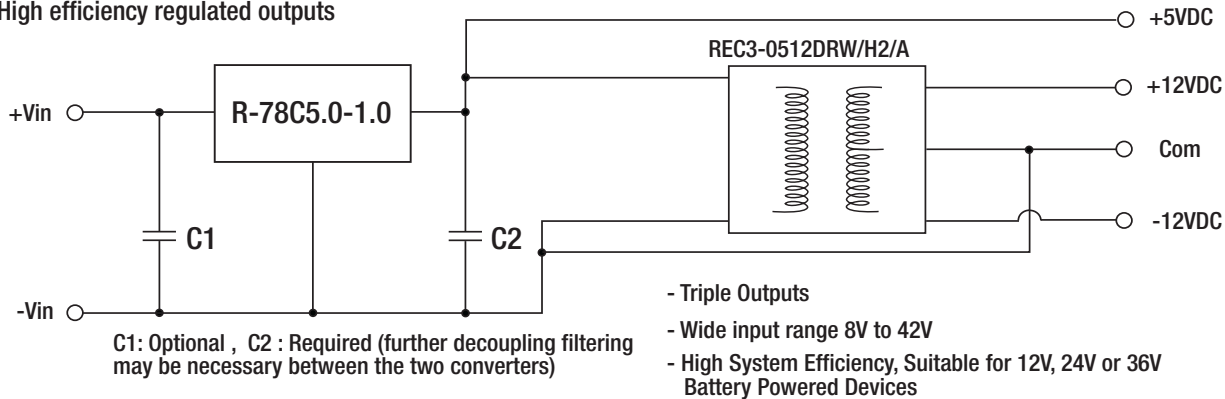

Standard Application Circuit with Class B EMC filter

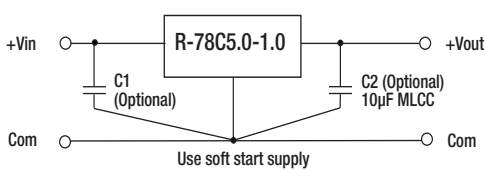

Low Voltage AC input, regulated DC output

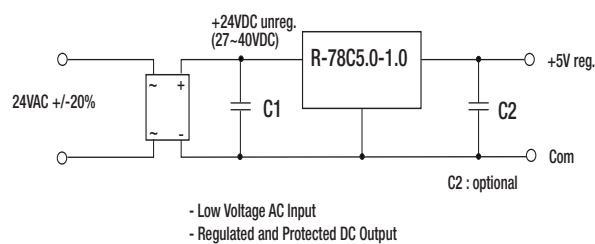

Package Style and Pinning (mm)

SIP3 PIN Package

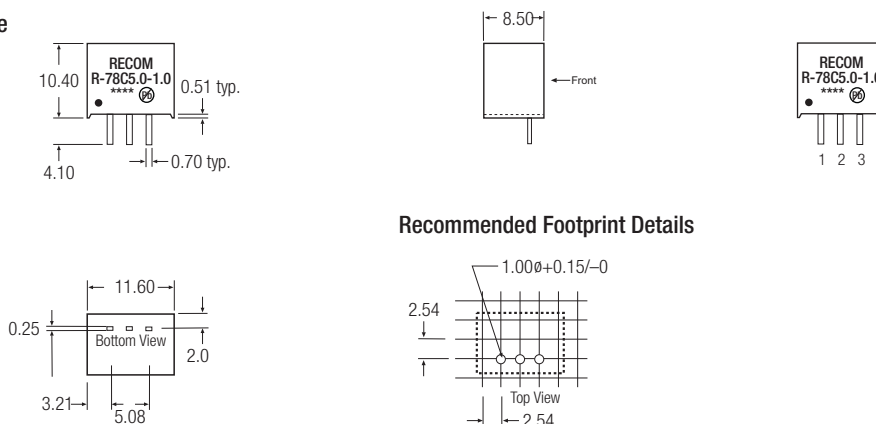

Pin Connections

Pin #	Connection
1	+Vin
2	GND
3	+Vout
xx.x	±0.5mm
xx.xx	±0.25mm

The product information and specifications are subject to change without prior notice. All products are designed for non-safety critical commercial and industrial applications. The Buyer agrees to implement safeguards that anticipate the consequences of any failures that might cause harm, loss of life and/or damage property.

Features

- Efficiency up to 97%, Non isolated, no need for heatsinks
- Pin-out compatible with LM78XX Linears
- Low profile (L*W*H=11.5*8.5*17.5mm)
- Wide input range. (4.75V ~ 34V)
- Short circuit protection, Thermal shutdown
- Non standard outputs available as specials between 1.5V ~15V
- Low ripple and noise
- "L" version with 90° pins
- See Ininline Application Notes for use as an inverter (alternative to LM79xx Linear)

Description

The R-78Bxx-1.0 Series high efficiency switching regulators are ideally suited to replace 78xx linear regulators and are pin compatible. The efficiency of up to 97% means that very little energy is wasted as heat so there is no need for any heat sinks with their additional space and mounting costs.

The L-Version with 90° pins allows direct replacement for laid-flat regulators where component height is at a premium. Low ripple and noise figures and a short circuit input current of typically only 10mA round off the specifications of this versatile converter series.

Selection Guide

Part Number SIP3	Input Range (V)	Output Voltage (V)	Output Current (A)	Efficiency	
				Min. Vin (%)	Max. Vin (%)
R-78B1.5-1.0	4.75 – 26	1.5	1.0	77	71
R-78B1.8-1.0	4.75 – 26	1.8	1.0	80	74
R-78B2.5-1.0	4.75 – 32	2.5	1.0	85	78
R-78B3.3-1.0	4.75 – 32	3.3	1.0	89	83
R-78B5.0-1.0	6.5 – 32	5.0	1.0	93	88
R-78B6.5-1.0	9.0 – 32	6.5	1.0	94	90
R-78B9.0-1.0	12 – 32	9.0	1.0	95	93
R-78B12-1.0	16 – 32	12	1.0	96	95
R-78B15-1.0	20 – 32	15	1.0	97	96

* add Suffix "L" for 90° bent pins, e.g. R-78B5.0-1.0L

Typical Application Circuit

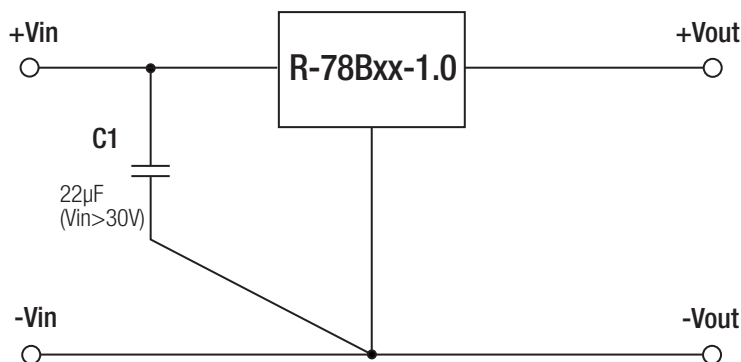

To protect the converter during power-up, use C1=22µF if Vin>30V

INNOLINE
DC/DC-Converter
with 3 year Warranty

RECOM

1.0 AMP
SIP3
Single Output



EN-55022 Certified
EN-55024 Certified
EN-60601-1-2 Certified
EN-60950-1 Certified

R-78B-1.0

Derating-Graph (Ambient Temperature)

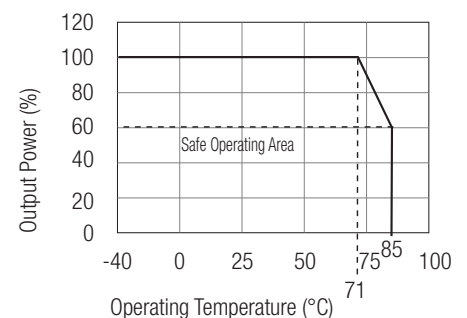

Refer to Application Notes

Specifications (refer to the standard application circuit, Ta: 25°C, minimum load = 10%)

Characteristics	Conditions	Min.	Typ.	Max.
Input Voltage Range	1.5V, 1.8V	4.75V	25	26V abs. max.
	2.5V to 15.5V	4.75V	32	34V abs. max.
Output Voltage Range (for customized parts)	All Series	1.5V		15.5V
Output Current (see Note 1)	All Series	0mA*		1000mA
Output Current Limit	All Series			2000mA
Short Circuit Input Current (Vin = 24V)	All Series			60mA
Internal Power Dissipation				0.65W
Short Circuit Protection			Continuous, automatic recovery	
Output Voltage Accuracy (At 100% Load)	All Series		±2%	±3%
Line Voltage Regulation (Vin = min. to max. at full load)	1.5V to 6.5V		0.2%	0.4%
	9V to 15.5V		0.1%	0.2%
Load Regulation (10% to 100% full load)	1.5V to 6.5V		0.4%	0.6%
	9V to 15.5V		0.25%	0.4%
Dynamic Load Stability (with Output Capacitor=100µF)	100% <-> 50% load		±100mV	±150mV
	Transient Recovery Time		1.0ms	1.5ms
Ripple & Noise (without Output Capacitor) (10% to 100% full load)	1.5V to 6.5V		15mVp-p	20mVp-p
	9V to 15.5V		25mVp-p	35mVp-p
Temperature Coefficient	-40°C ~ +85°C ambient			0.015%/°C
Max capacitance Load	with normal start-up time, no external components			470µF
	with <1 second start up time + diode protection circuit			6800µF
Switching Frequency		280kHz	330kHz	380kHz
Quiescent Current	Vin = min. to max. at 0% load		5mA	7mA
Input Reflected Ripple Current	All Series		150mA	200mA _{p-p}
Operating Temperature Range		-40°C		+85°C
Operating Case Temperature				+100°C
Storage Temperature Range		-55°C		+125°C
Case Thermal Impedance				60°C / W
Thermal Shutdown	Internal IC junction			+160°C
Relative Humidity				95% RH
Thermal Shutdown	Internal IC junction		+160°C	
Case Material			Epoxy with Non-Conductive Plastic Case (UL94V-0)	
Package Weight			4g	
Packing Quantity				42 pcs per Tube
Conducted Emissions	EN55022			Class B
Radiated Emissions	EN55022			Class B
ESD	EN61000-4-2			Class A
Safety Certification	Report: SPCLVD 1301026-1		EN 60950-1:2006 + A12:2011	
MTBF (+25°C) (+71°C)	} Detailed Information see Application Notes chapter "MTBF"	using MIL-HDBK 217F		6584 x 10 ³ hours
		using MIL-HDBK 217F		1139 x 10 ³ hours

*Note: Operation under no load will not damage these devices, however they may not meet all specifications. A minimum load of 10mA is recommended

Characteristics

Efficiency

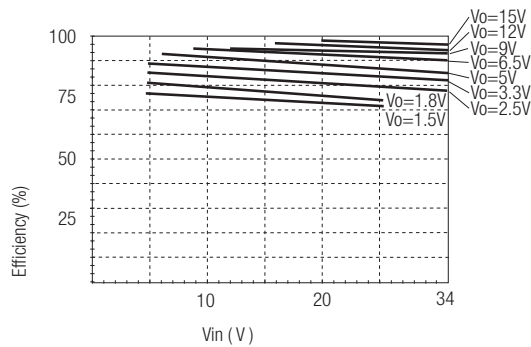

Efficiency Vs Vin (Full Load)

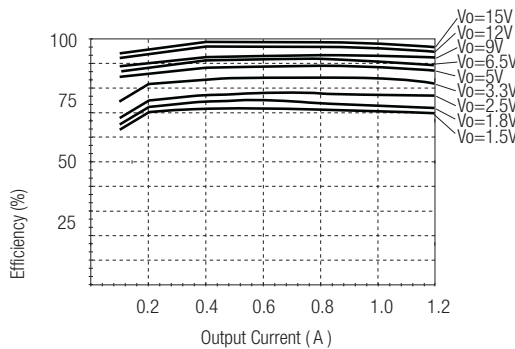

Efficiency Vs Load (Vin=Max)

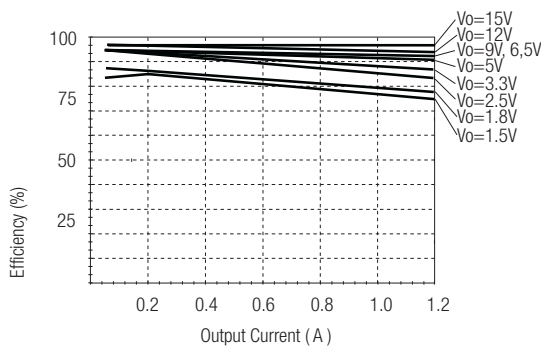

Efficiency Vs Load (Vin=Min)

Ripple

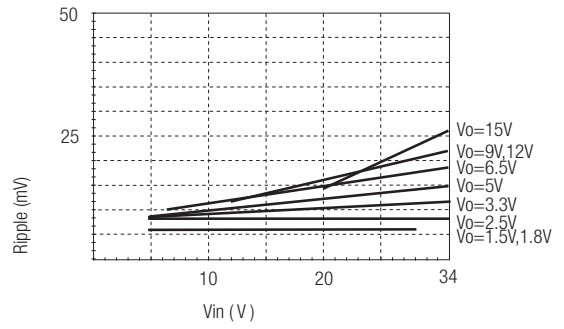

Ripple Vs Vin (Full Load)

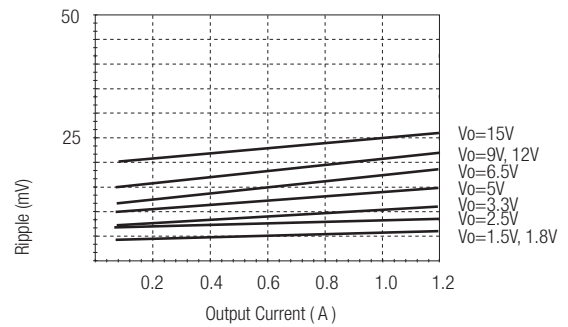

Ripple Vs Load (Vin=Max)

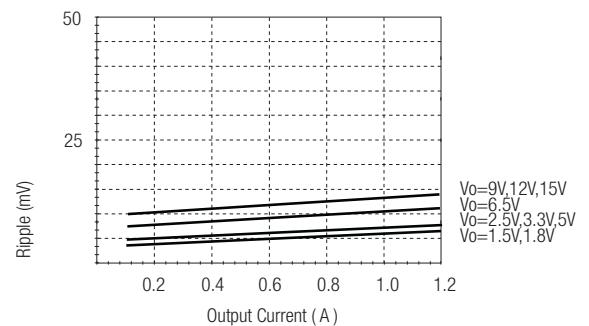

Ripple Vs Load (Vin=Min)

R-78B-1.0

Optional Protection Circuit

Optional Protection 1:

Add a blocking diode to Vout if current can flow backwards into the output, as this can damage the converter when it is powered down.

The diode can either be fitted across the device if the source is low impedance or fitted in series with the output (recommended).

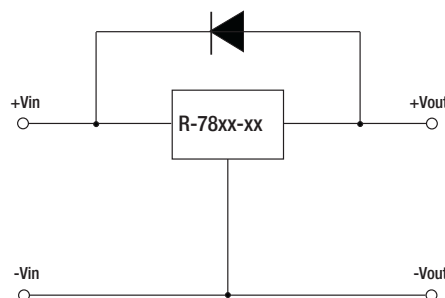

Optional Protection 2:

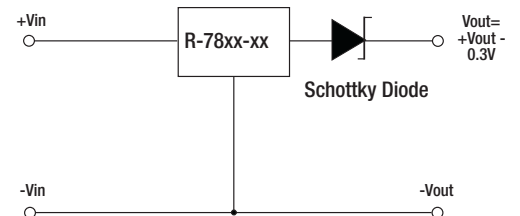

Application Examples

High efficiency multiple output

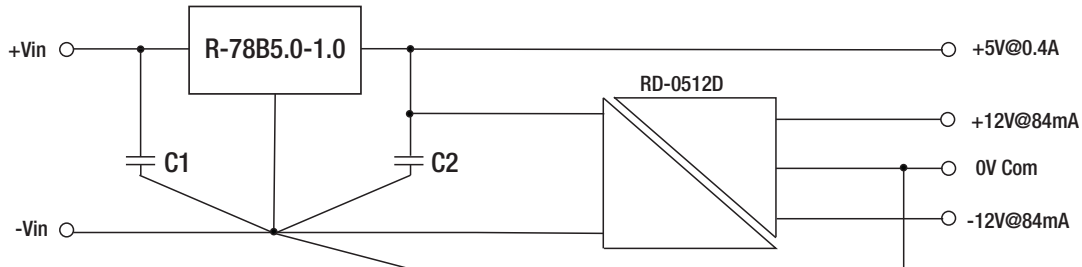

C1: optional, C2: required (further decoupling filtering may be necessary between the two converters)

- Wide input range 6.5V to 34V
- +/-12V outputs for analogue circuits, e.g. instrumentation amplifier
- +5V output for digital circuits

Isolated, wide Input range, Distributed Power Architecture (Point of Load)

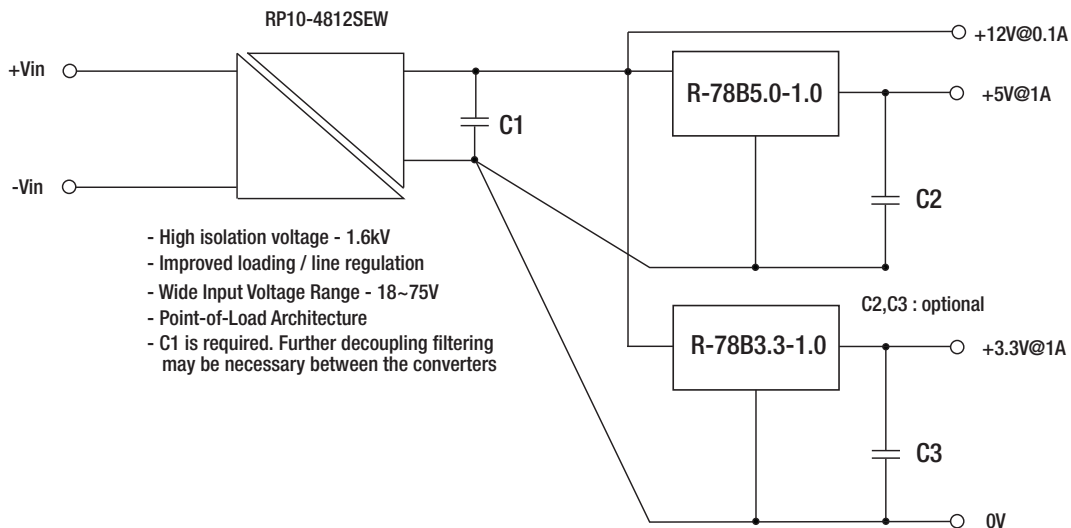

- High isolation voltage - 1.6kV
- Improved loading / line regulation
- Wide Input Voltage Range - 18~75V
- Point-of-Load Architecture
- C1 is required. Further decoupling filtering may be necessary between the converters

C2,C3 : optional

R-78B-1.0

Package Style and Pinning (mm)

SIP3 PIN Package

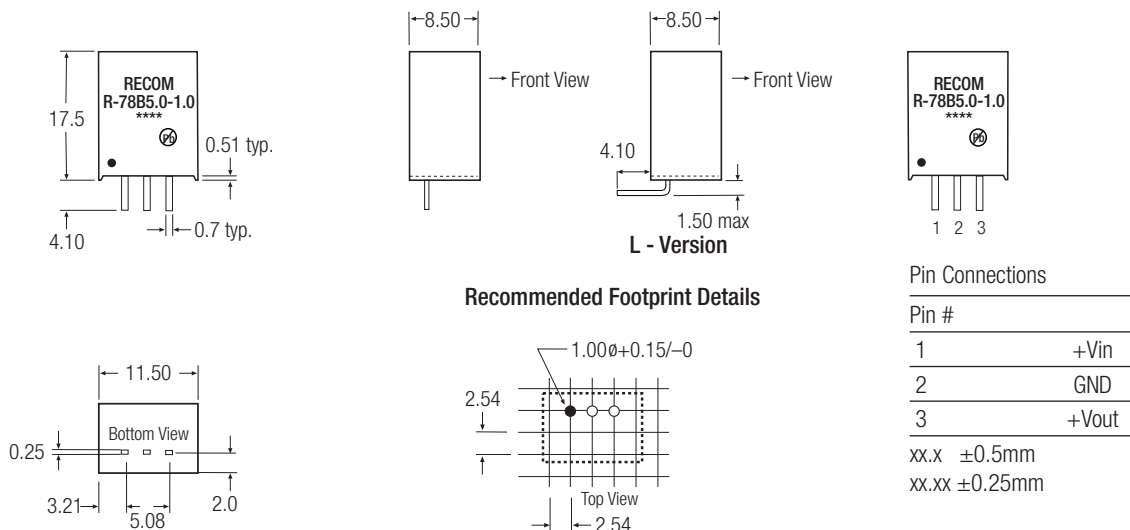

Features

- Efficiency up to 95%, Non isolated, no need for heatsinks
- Pin-out compatible with LM78XX Linears
- Low profile (L*W*H=11.5*8.5*17.5mm)
- Wide input range. (4.75V ~ 18V)
- Short circuit protection, Thermal shutdown
- Non standard outputs available as specials between 1.5V ~ 6.5V
- Low ripple and noise
- "L" Version with 90° pins

Description

The R-78Bxx-1.5 Series high efficiency switching regulators are ideally suited to replace 78xx linear regulators and are pin compatible. The efficiency of up to 95% means that very little energy is wasted as heat so there is no need for any heat sinks with their additional space and mounting costs. The L-Version with 90° pins allows direct replacement for laid-flat regulators where component height is at a premium. Low ripple and noise figures and a short circuit input current of typically only 10mA round off the specifications of this versatile converter series.

Selection Guide

Part Number* SIP3	Input Range (V)	Output Voltage (V)	Output Current (A)	Efficiency	
				Min. Vin (%)	Max. Vin (%)
R-78B1.5-1.5	4.75 – 18	1.5	1.5	83	78
R-78B1.8-1.5	4.75 – 18	1.8	1.5	85	81
R-78B2.5-1.5	4.75 – 18	2.5	1.5	88	84
R-78B3.3-1.5	4.75 – 18	3.3	1.5	91	88
R-78B5.0-1.5	6.5 – 18	5.0	1.5	94	92
R-78B6.5-1.5	8.0 – 18	6.5	1.5	95	93

* add Suffix "L" for 90° bent pins, e.g. R-78B5.0-1.5L

INNOLINE
DC/DC-Converter
with 3 year Warranty

RECOM

1.5 AMP
SIP3
Single Output



EN-55022 Certified
EN-55024 Certified
EN-60950-1 Certified

R-78B-1.5

Typical Application Circuit

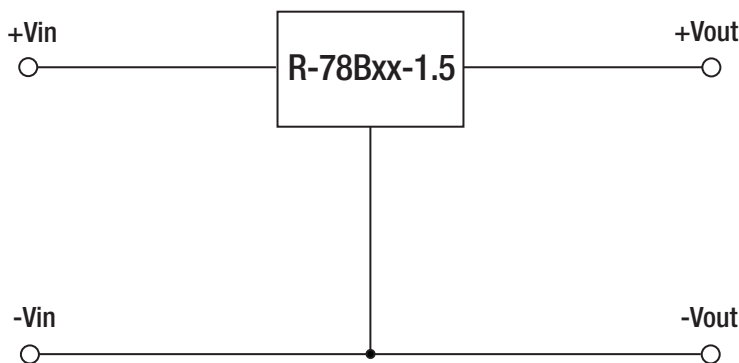

Derating-Graph (Ambient Temperature)

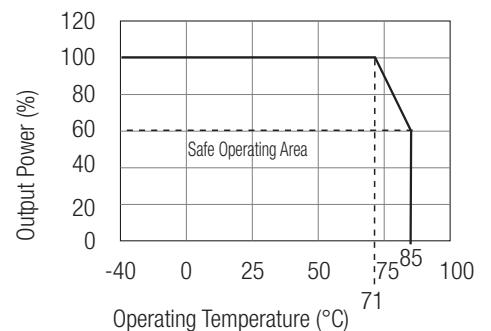

Refer to Application Notes

Specifications (refer to the standard application circuit, Ta: 25°C, minimum load = 10 %)

Characteristics	Conditions	Min.	Typ.	Max.
Input Voltage Range	All Series, see Selection Guide	4.75V		18.0V
Output Voltage Range (for customized parts)	All Series	1.5V		6.5V
Output Current	All Series	0mA*		1500mA
Output Current Limit	All Series			5000mA
Short Circuit Input Current (Vin = 12V)	All Series			100mA
Internal Power Dissipation				0.65W
Short Circuit Protection			Continuous, automatic recovery	
Output Voltage Accuracy (At 100% Load)	All Series		±2%	±3%
Line Voltage Regulation (Vin = min. to max. at full load)	All Series		0.3%	0.5%
Load Regulation (10% to 100% full load)	All Series		0.6%	0.8%
Dynamic Load Stability (with Output Capacitor=100µF)	100% <-> 50% load		±80mV	±120mV
	Transient Recovery Time		1.0ms	1.5ms
Ripple & Noise (10% to 100% full load)	All Series		15mV	30mVp-p
Temperature Coefficient	-40°C ~ +85°C ambient			0.015%/°C
Max capacitance Load	with normal start-up time, no external components			1000µF
	with <1 second start up time + diode protection circuit			6800µF
Switching Frequency		300kHz	340kHz	380kHz
Quiescent Current	Vin = min. to max. at 0% load		7mA	9mA
Input Reflected Ripple Current	All Series		150mA	200mA _{p-p}
Operating Temperature Range		-40°C		+85°C
Operating Case Temperature				+100°C
Storage Temperature Range		-55°C		+125°C
Case Thermal Impedance				60°C / W
Thermal Shutdown	Internal IC junction			+160°C
Relative Humidity				95% RH
Case Material			Epoxy with Non-Conductive Plastic Case (UL94V-0)	
Package Weight			4g	
Packing Quantity				42 pcs per Tube
Conducted Emissions	EN55022			Class B
Radiated Emissions	EN55022			Class B
ESD	EN61000-4-2			Class A
Safety Certification	Report: SPCLVD 1301026-1		EN-60950-1:2006 + A12:2011	
MTBF (+25°C) (+71°C)	} Detailed Information see Application Notes chapter "MTBF"	using MIL-HDBK 217F		3250 x 10 ³ hours
		using MIL-HDBK 217F		1059 x 10 ³ hours

*Note: Operation under no load will not damage these devices, however they may not meet all specifications. A minimum load of 10mA is recommended

Characteristics

Efficiency

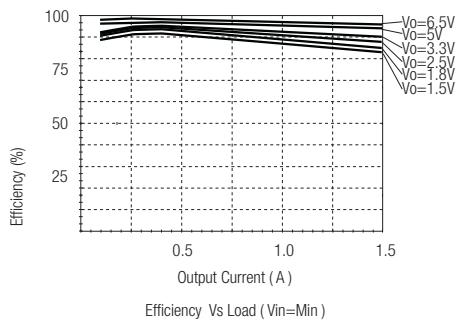
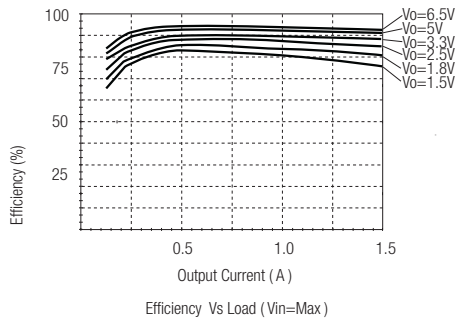
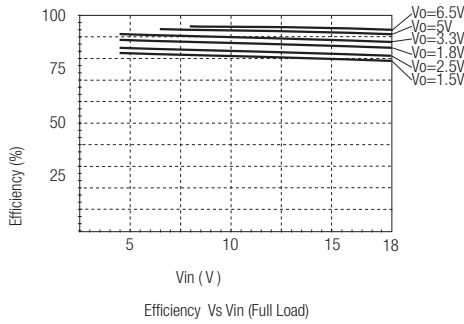

Ripple

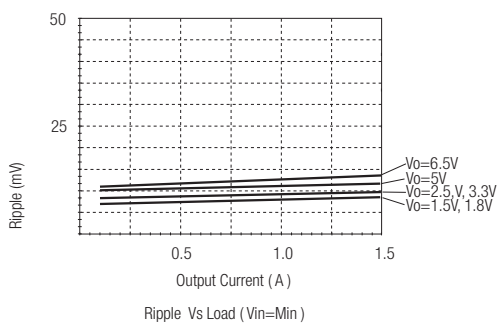
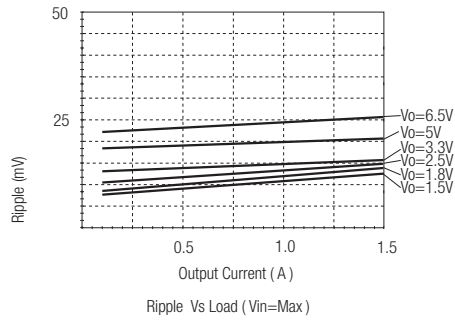
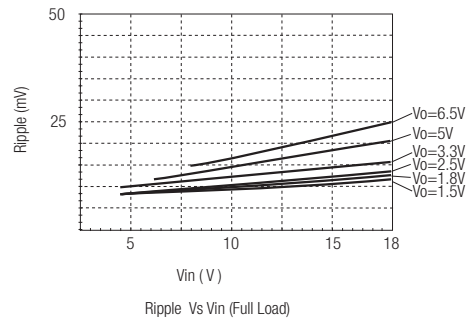

Optional Protection Circuit

Optional Protection 1:

Add a blocking diode to Vout if current can flow backwards into the output, as this can damage the converter when it is powered down.

The diode can either be fitted across the device if the source is low impedance or fitted in series with the output (recommended).

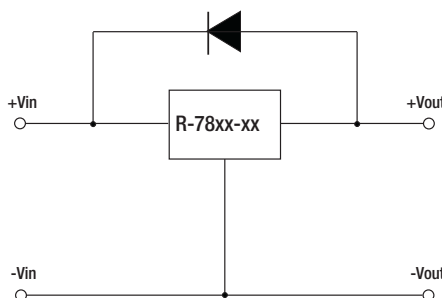

Optional Protection 2:

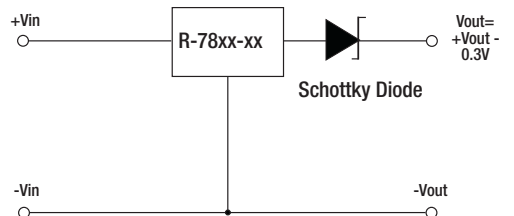

Application Examples

High efficiency multiple output

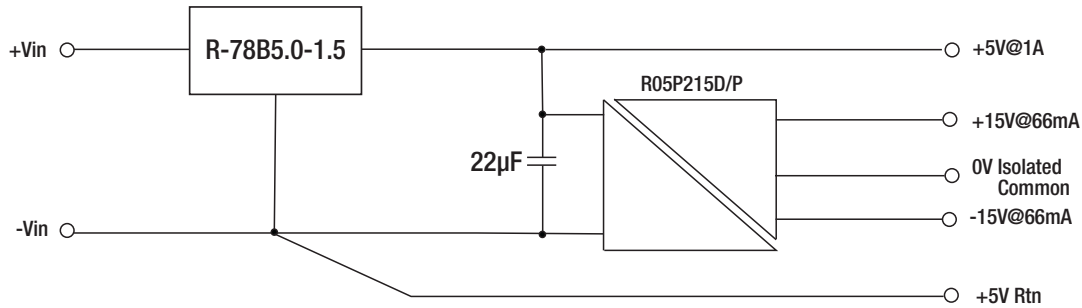

- Wide input range suits both 12V and 7.2V battery packs
- 5.2kV isolated short circuit protected outputs for analogue circuits, e.g. medical grade interface
- High efficiency +5V/1A protected output for digital circuits
- Further decoupling filtering may be necessary between the converters

Isolated, wide Input range, Distributed Power Architecture (Point of Load)

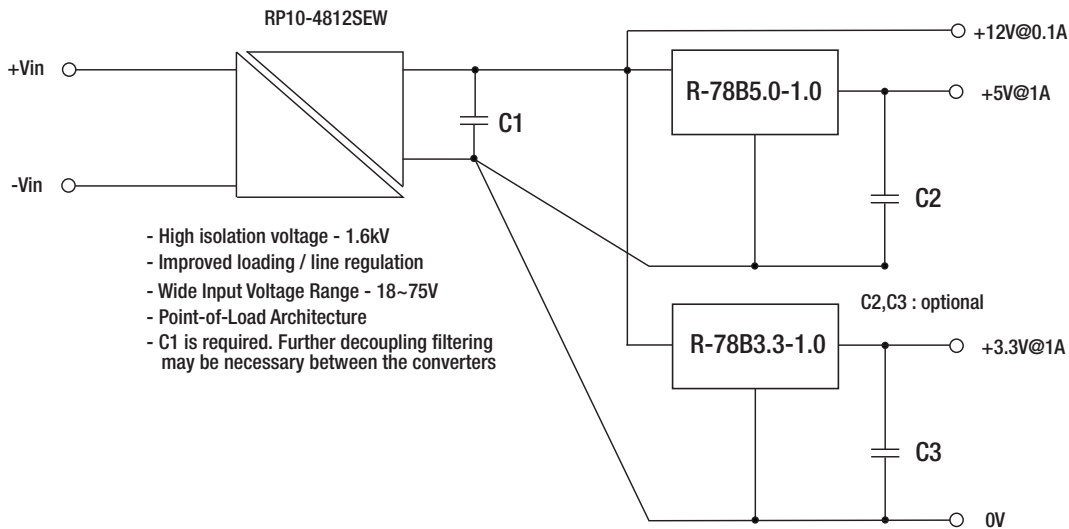

- High isolation voltage - 1.6kV
- Improved loading / line regulation
- Wide Input Voltage Range - 18~75V
- Point-of-Load Architecture
- C1 is required. Further decoupling filtering may be necessary between the converters

R-78B-1.5

Package Style and Pinning (mm)

SIP3 PIN Package

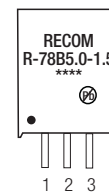
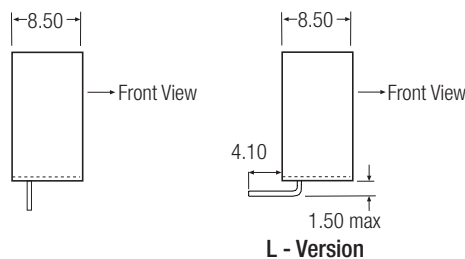
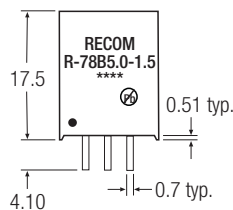

Pin Connections

Pin #	Connection
1	+Vin
2	GND
3	+Vout

xx.x ±0.5mm
xx.xx ±0.25mm

Recommended Footprint Details

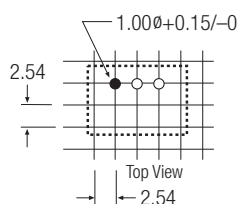
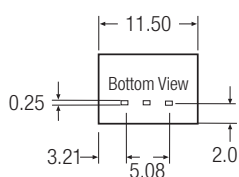

Features

- Efficiency up to 96%, Non isolated, no need for heatsinks
- Pin-out compatible with LM78XX Linears
- Low profile(L*W*H=11.5*8.5*17.5mm)
- High voltage input range, up to 72V
- Short circuit protection, Thermal shutdown
- Non standard outputs available as specials between 3.3V~24V
- Low ripple and noise
- "L" version with 90° pins
- See Ininline Application Notes for use as an inverter (alternative to LM79xx Linear)

Description

The R-78HBxx-Series high efficiency, high input voltage switching regulators are ideally suited to replace 78xx linear regulators and are pin compatible. The efficiency of up to 96% means that very little energy is wasted as heat so there is no need for any heat sinks with their additional space and mounting costs.

An input voltage range of up to 8:1 is unsurpassed by any other converter and allows the full stored energy utilisation of standard and high voltage batteries. The fully protected output is ideal for industrial applications (especially for industry standard 24VDC bus supplies) and the L-Version with 90° pins allows direct replacement for laid-flat regulators where component height is at a premium. Low ripple and noise figures and a short circuit input current of typically only 15mA round off the specifications of this versatile converter series.

Typical applications include telecommunication, automotive, industrial, aerospace and battery powered applications.

Selection Guide

Part Number SIP3	Input Range (V)	Output Voltage (V)	Output Current (A)	Efficiency		
				Vmin. (%)	30V (%)	72V (%)
R-78HB3.3-0.5	9 - 72	3.3	0.5	82	80	76
R-78HB5.0-0.5	9 - 72	5.0	0.5	87	85	81
R-78HB6.5-0.5	9 - 72	6.5	0.5	91	87	84
R-78HB9.0-0.5	14 - 72	9.0	0.5	92	90	86
R-78HB12-0.5	17 - 72	12	0.5	94	93	89
R-78HB15-0.5	20 - 72	15	0.5	95	94	91
R-78HB24-0.3	36 - 72	24	0.3	96		92

* add Suffix "L" for 90° bent pins, e.g. R-78HB5.0-0.5L

Typical Application Circuit

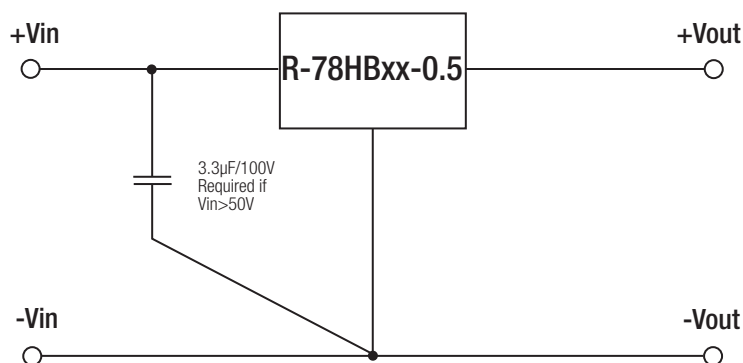

The converter has a built in soft start circuit. Rapidly changing the input voltage from Vin(min) ↔ Vin(max) can bypass this circuit and damage the converter.

INNOLINE
DC/DC-Converter
with 3 year Warranty

RECOM

0.5 AMP
SIP3
Single Output



EN-55022 Certified
EN-55024 Certified
EN-60950-1 Certified

R-78HB

Derating-Graph (Ambient Temperature)

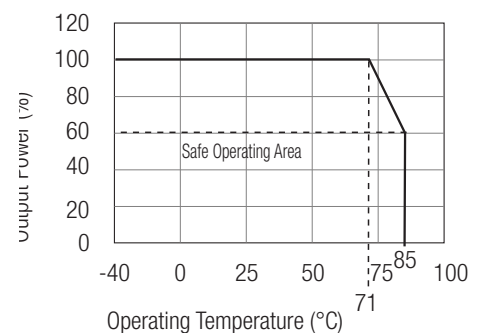

Refer to Application Notes

Specifications (refer to the standard application circuit, Ta: 25°C, minimum load = 10%)

Characteristics	Conditions	Min.	Typ.	Max.
Input Voltage Range	See table	9V	72V	75V Absolute Max.
Output Voltage Range (for customized parts)	All Series	3.3V		24V
Output Current (see Note 1)	3.3V, 5V, 6.5V, 9V, 12V, 15V	10mA		500mA
	24V	6mA		300mA
Output Current Limit (Vin = 48VDC)	All Series		700mA	1200mA
Short Circuit Input Current	All Series		15mA	25mA
Internal Input Filter				1µF Capacitor
Internal Power Dissipation				0.65W
Short Circuit Protection		Continuous, automatic recovery		
Output Voltage Accuracy	At 100% Load		±2%	±3%
Line Voltage Regulation	Vin = min. to max. at full load		0.4%	1%
Load Regulation	10% to 100% full load		0.3%	0.6%
Dynamic Load Stability (with Output Capacitor=100µF)	100% <-> 50% load		±75mV	±100mV
Ripple & Noise (without Output Capacitor)	10% to 100% full load		20mVp-p	60mVp-p
Temperature Coefficient	-40°C ~ +85°C ambient			0.015%/°C
Max capacitance Load	with normal start-up time, no external components with <1 second start up time + diode protection circuit			100µF 6800µF
Switching Frequency (See Graph)	Full Load	120kHz		800kHz
Quiescent Current	Vin = 48VDC. at minimum load	1mA		5mA
Operating Temperature Range		-40°C		+85°C
Operating Case Temperature				+100°C
Storage Temperature Range		-55°C		+125°C
Case Thermal Impedance				60°C / W
Thermal Shutdown	Internal IC junction			+160°C
Relative Humidity				95% RH
Case Material				Non-Conductive Black Plastic
Potting Material				Epoxy (UL94V-0)
Package Weight			4g	
Packing Quantity				42 pcs per Tube
Soldering Temperature				265°C max./10 sec.
Conducted Emissions	EN55022			Class B
Radiated Emissions	EN55022			Class B
ESD	EN61000-4-2			Class A
Safety Certification	Report: SPCLVD 1301026-1			EN-60950-1:2006 + A12:2011
MTBF (+25°C)	} Detailed Information see Application Notes chapter "MTBF"	using MIL-HDBK 217F		7395 x 10 ³ hours
(+71°C)		using MIL-HDBK 217F		1242 x 10 ³ hours

Switching Frequency vs Load

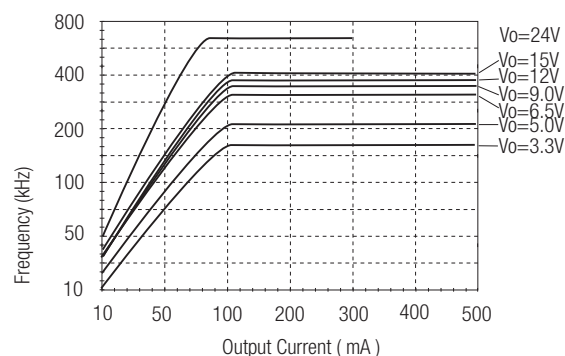

Switching Frequency Vs Load (Vin=30~72V)

Typical Characteristics

Efficiency

Ripple

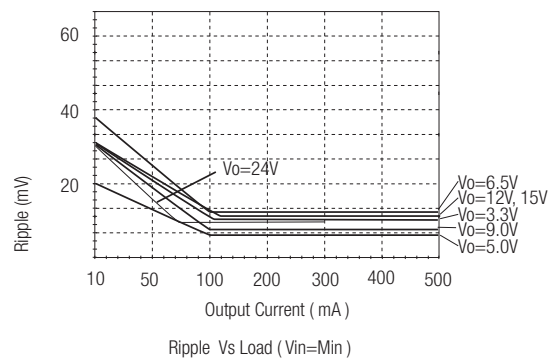
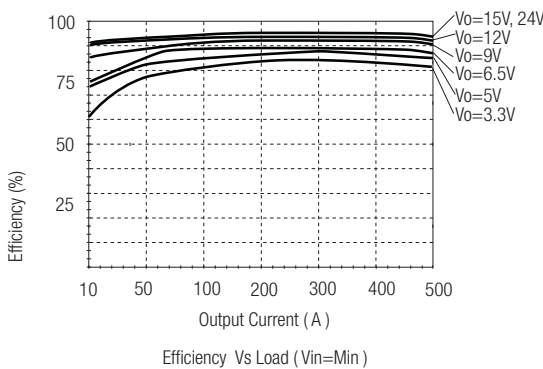
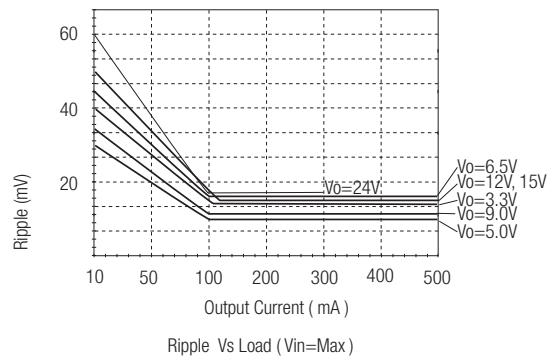
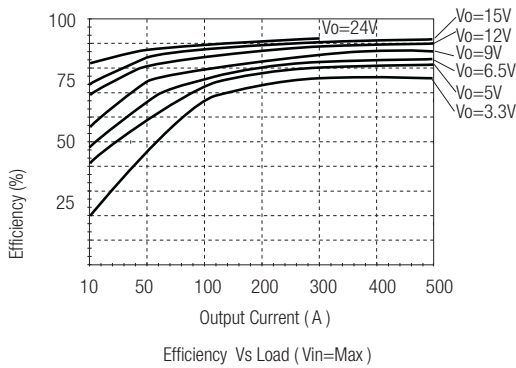
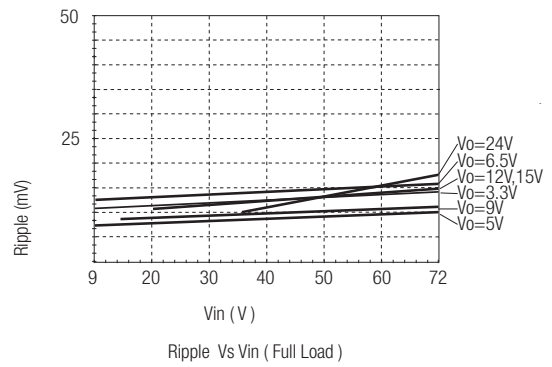
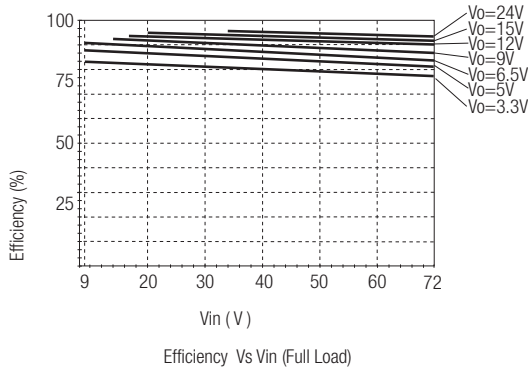

*Note: Operation under no load will not damage these devices, however they may not meet all specifications. A minimum load of 10mA is recommended

Optional Protection Circuit

Optional Protection 1:

Add a blocking diode to Vout if current can flow backwards into the output, as this can damage the converter when it is powered down.

The diode can either be fitted across the device if the source is low impedance or fitted in series with the output (recommended).

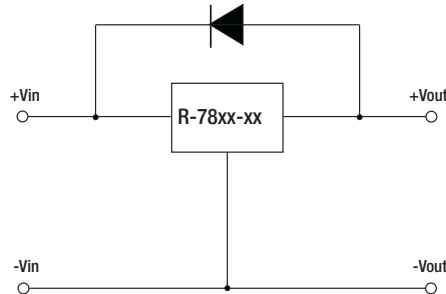

Optional Protection 2:

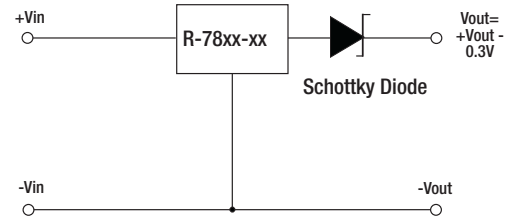

Typical Application

High Input Voltage Multiple Output Supply

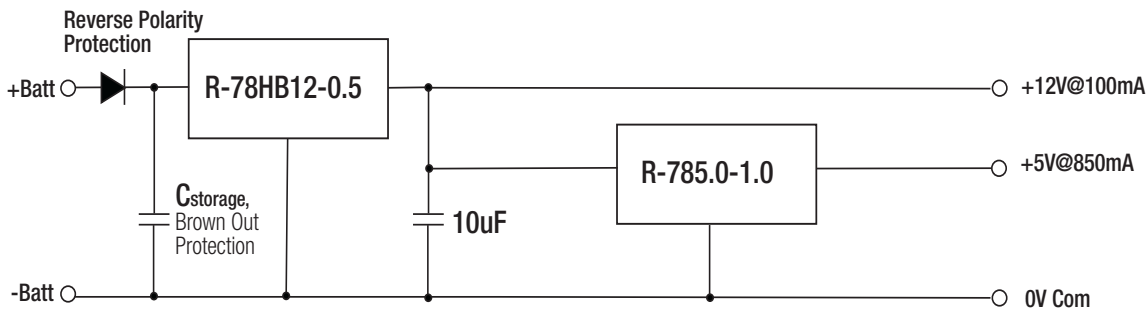

- Wide input range 18V to 72V - can be used with 24V, 48V or 60V batteries
- +12V output for interface and display electronics
- +5V high current output for digital electronics
- Further decoupling filtering may be necessary between the converters

R-78HB

Package Style and Pinning (mm)

SIP3 PIN Package

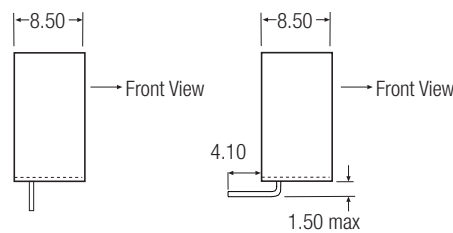
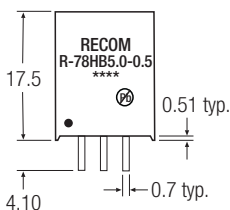

L - Version

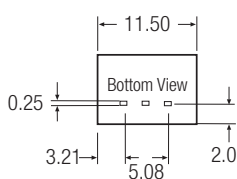
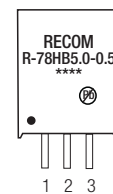

Recommended Footprint Details

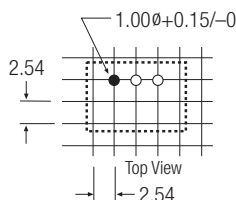

Pin Connections

Pin #	Connection
1	+Vin
2	GND
3	+Vout

xx.x ±0.5mm
xx.xx ±0.25mm

Features

- Efficiency up to 95%, no Need for Heatsinks!
- Industry Standard Pin-Out
- 1.5A Start-Up Overload Capacity
- Non-Isolated Regulator with very low Standby Current
- Wide Input Range (7V ~ 42V)
- Short Circuit Protection
- Fixed Switching Frequency (350kHz), Shielded Magnetics

Selection Guide

Part Number SIP3	Input Range (V)	Output Voltage (V)	Output Current (A)	Efficiency	
				Min. Vin (%)	Max. Vin (%)
R-78T3.3-1.0*	7 – 42	3.3	1.0	88	79
R-78T5.0-1.0*	8 – 42	5.0	1.0	92	85
R-78T12-1.0*	15 – 42	12	1.0	95	92

*add suffix /FC, /AC or /AL for required pinning option

Specifications (typical at 25°C, 10% minimum load, unless otherwise specified)

Input Voltage Range	3.3V	7-42VDC
	5V	8-42VDC
	12V	15-42VDC
No Load Input Current		1mA typ.
Input Filter		C Filter
Voltage Accuracy		±2% typ. / ±3% max.
Line Regulation	(LL to HL at Full Load)	±0.2% typ.
Load Regulation	(10-100%)	±0.4% typ.
Minimum Load		10%
Ripple & Noise (20MHz Limited)		50mVp-p typ. / 100mVp-p max.
Transient Response 50mA/uS	100% - 50% Load	±250mV max.
Operating Frequency		350KHz typ.
Current Limit		1.5A / 10sec max.
Short Circuit Protection		Current limited to 3.5A typ.
Operating Temperature		-40°C to 85°C
Storage Temperature		-55°C to 125°C
Humidity		5% to 95% RH max.
Dimension	suffix /AC or /AL	23 x 27.2 x 10mm
	suffix /FC	23 x 29.4 x 8mm
Weight		4.5g typ.
Cooling Method		Free Air Convection
MTBF (25°C)	MIL-HDBK-217F	367 x 10 ³ hours

Standard Application Circuit

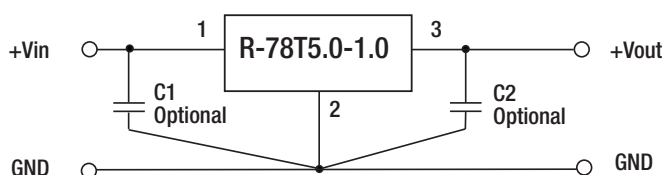

INNOLINE
DC/DC-Converter
with 3 year Warranty

RECOM

1.0 AMP
SMD
Single Output



R-78T-1.0

Derating-Graph (Ambient Temperature)

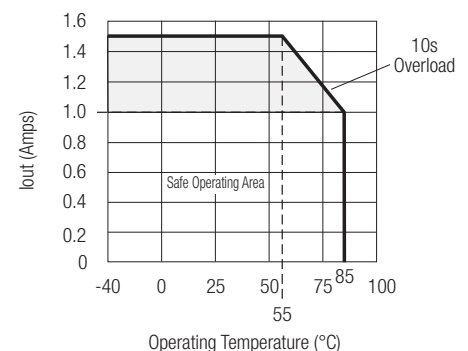

Refer to Application Notes

Typical Characteristics

Efficiency

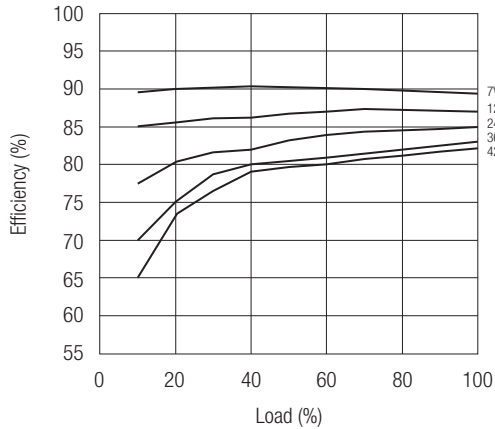

R-78T3.3-1.0

Ripple

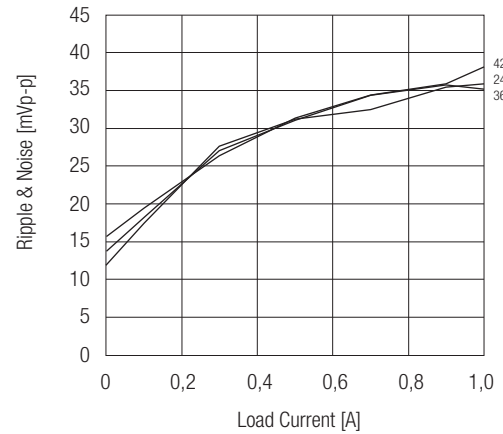

R-78T5.0-1.0

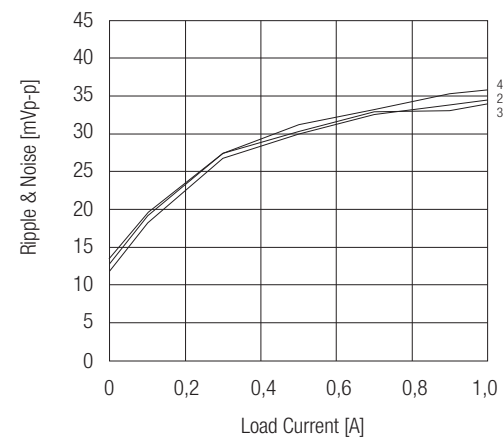
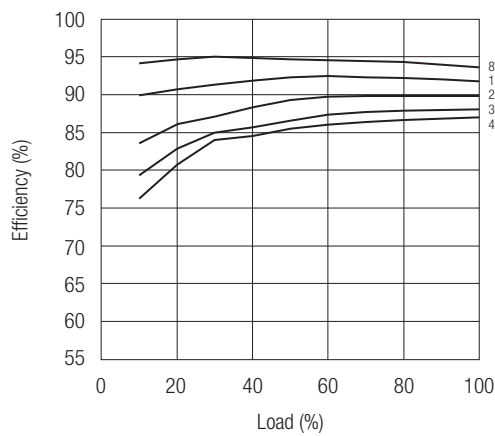

R-78T12-1.0

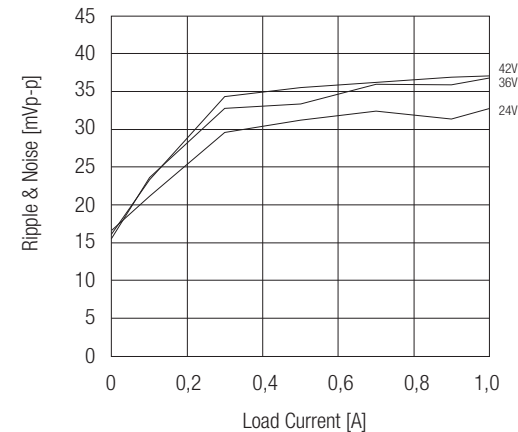
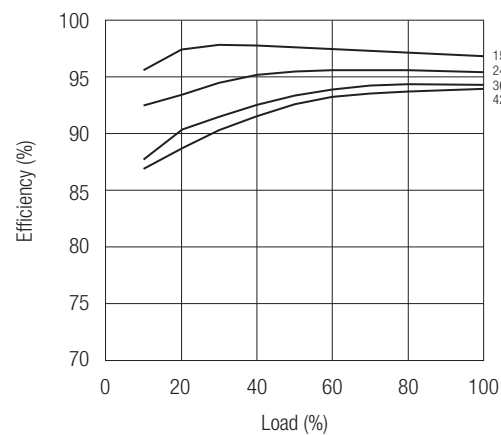

Package Style and Pinning (mm)

R-78Txx-1.0/AC

Recommended Footprint

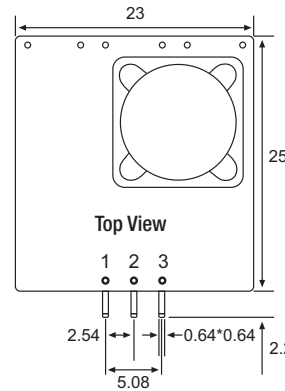
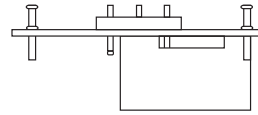
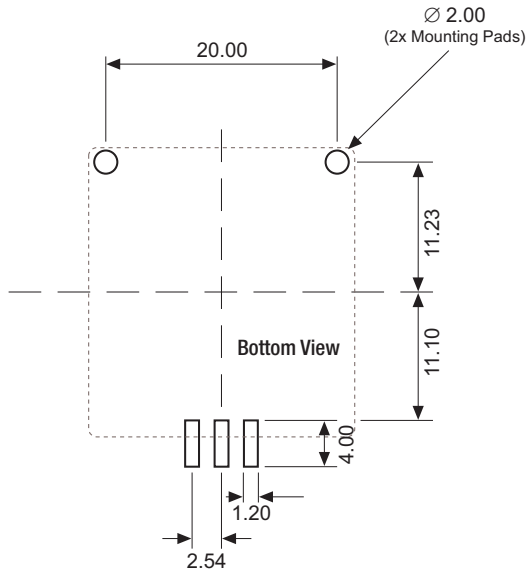

Pin Connections

Pin #	Connection
1	+Vin
2	GND
3	+Vout

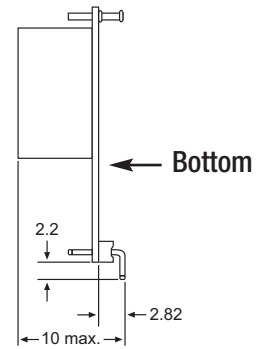

Tolerance $\pm 0.5\text{mm}$ unless otherwise specified

R-78Txx-1.0/AL

Recommended Footprint

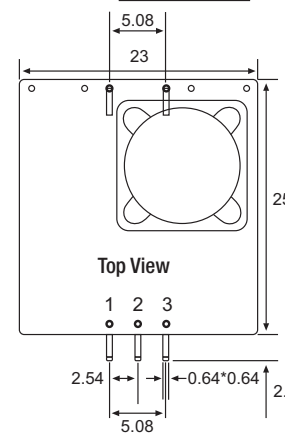
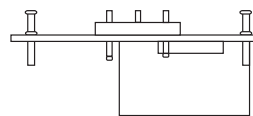
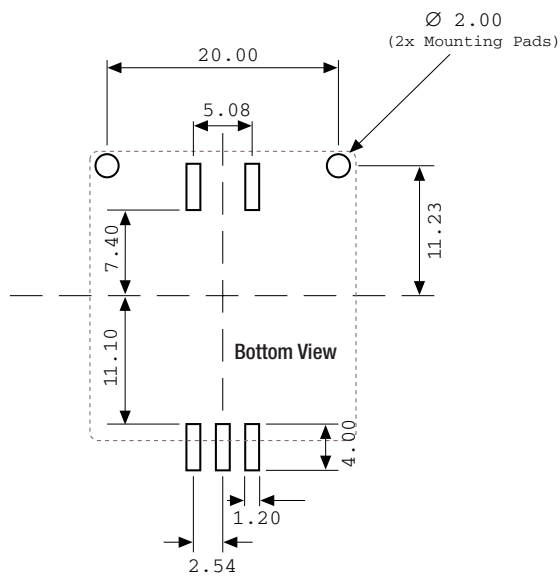

Pin Connections

Pin #	Connection
1	+Vin
2	GND
3	+Vout

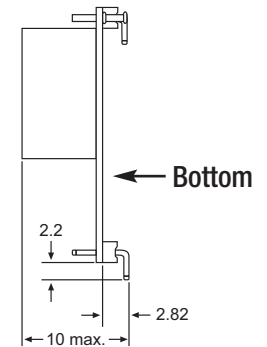

Tolerance $\pm 0.5\text{mm}$ unless otherwise specified

Package Style and Pinning (mm)

R-78Txx-1.0/FC

Recommended Footprint

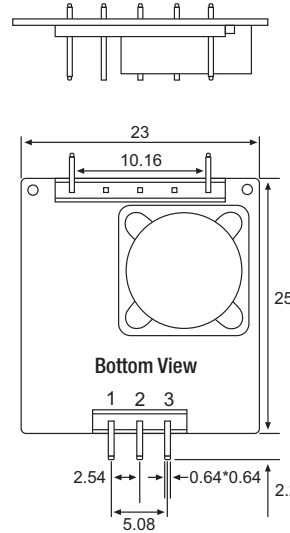
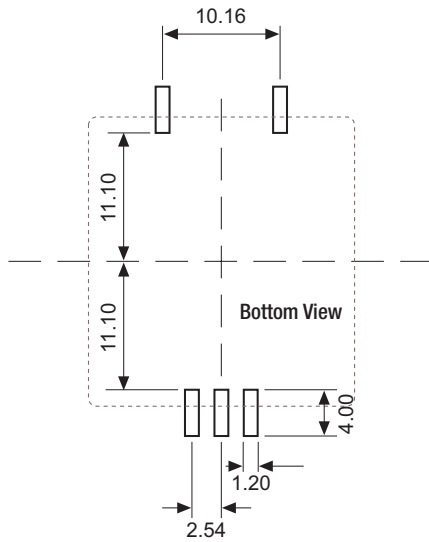

Pin Connections	
Pin #	
1	+Vin
2	GND
3	+Vout

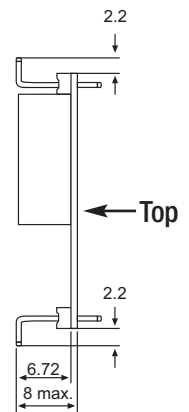

Tolerance $\pm 0.5\text{mm}$ unless otherwise specified

Features

- Low Profile 4.5mm
- Low Cost
- Wide Input Range (5V - 36V)
- Short Circuit Protection
- Castellated Connections

Selection Guide

Part Number	Input Range (VDC)	Output Voltage (VDC)	Output Current (mA)	Efficiency (%)
ROF-78E3.3-0.5SMD*	5 - 36	3.3	500	73 - 84
ROF-78E5.0-0.5SMD*	9 - 36	5.0	500	79 - 87

* add Suffix „-R“ for tape & reel packing - e.g. ROF78Exx-0.5SMD-R

Specifications (measured at Ta=25°C, Full Load after Warm-Up)

Input Voltage Range	5 - 36 VDC (12/24V typ)	
No Load Input Current	5mA max.	
Maximum Input Current	0.5A max.	
Short Circuit Input Current	200mA max.	
Voltage Accuracy	±5% max.	
Line Regulation	(LL to HL at Full Load)	±1% max.
Load Regulation	(10 ~ 100%)	±3% max.
Minimum Load*	10%	
Ripple & Noise	(20MHz Limited)	100mV max.
Transient Response	100% ~ 50% Load	±100mV
(20MHz Limited)	100% ~ 10% Load	±200mV
Operating Frequency	650KHz typ.	
ON/OFF Enable Pin	ON: Open or >1.75V	OFF: GND or <0.7V
(max. Input Voltage = 5V)		
Current Limit	950mA typ.	
Short Circuit Protection	Auto Recovery	
Operating Temperature	-40°C ~ 85°C	
Storage Temperature	-55°C ~ 125°C	
Humidity	95% RH	
Dimension (L x W x H)	12.5 x 13.5 x 4.5 mm	
Weight	1g	
Cooling Method	Free Air Convection	
MTBF (25°C)	MIL-HDBK-217F	3500 x 10 ³ hours

*Operation at no load will not damage these devices, but they may not meet all of the datasheet specifications.

INNOLINE
DC/DC-Converter
with 3 year Warranty

RECOM

Non Isolated Power Module



ROF-78E

Derating-Graph (Ambient Temperature)

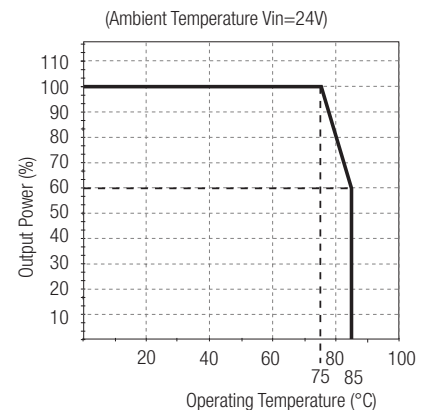

Refer to Application Notes

Characteristics

Efficiency

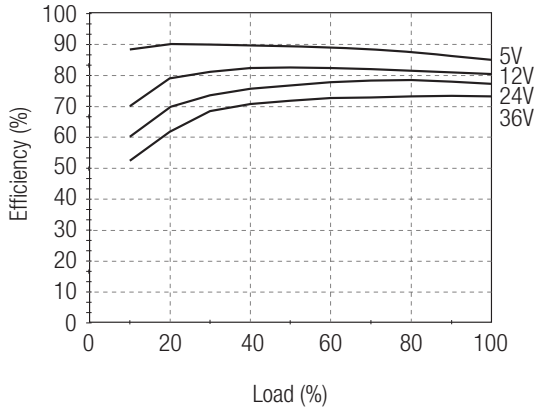

ROF-78E3.3-0.5SMD

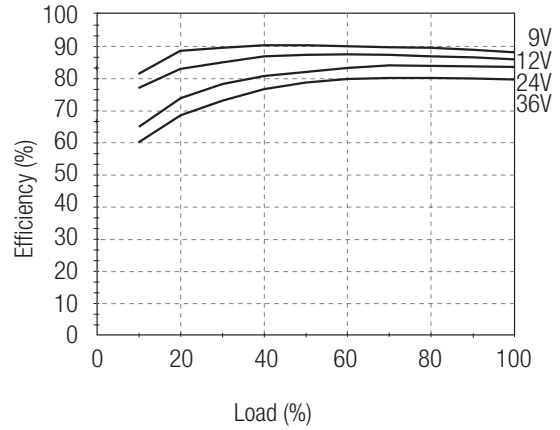

ROF-78E5.0-0.5SMD

Ripple

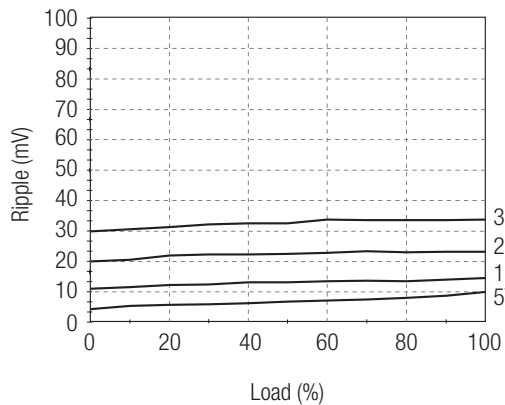

ROF-78E3.3-0.5SMD

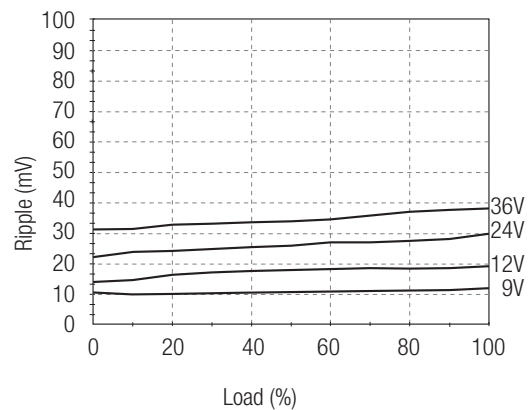

ROF-78E5.0-0.5SMD

Applications

Standard Application Circuit

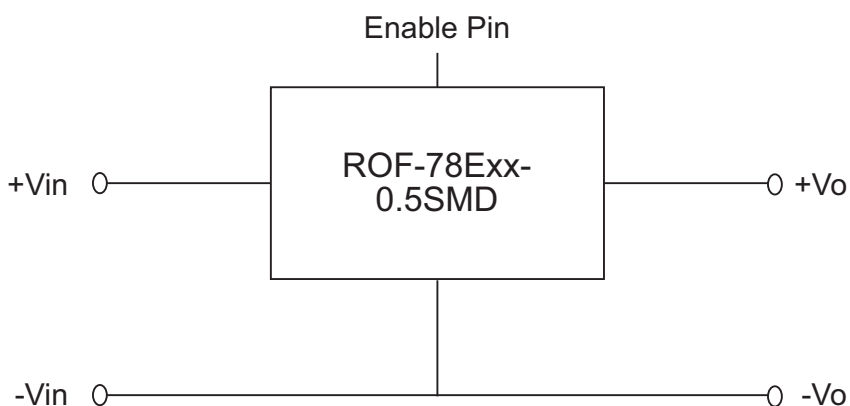

Applications

Application Examples

High efficiency, isolated, dual unregulated outputs

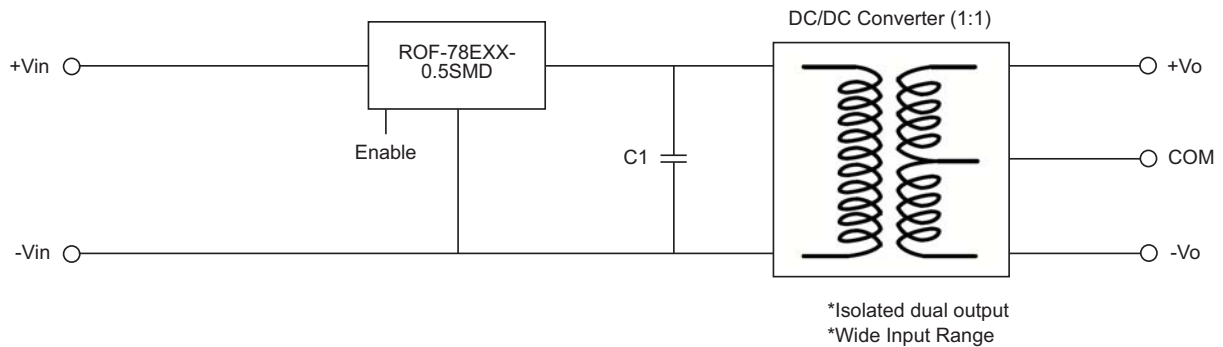

Isolated (Up to 6KV), wide input range regulated output

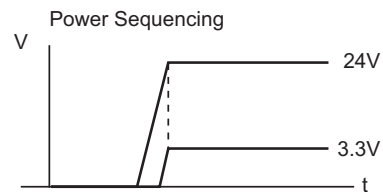
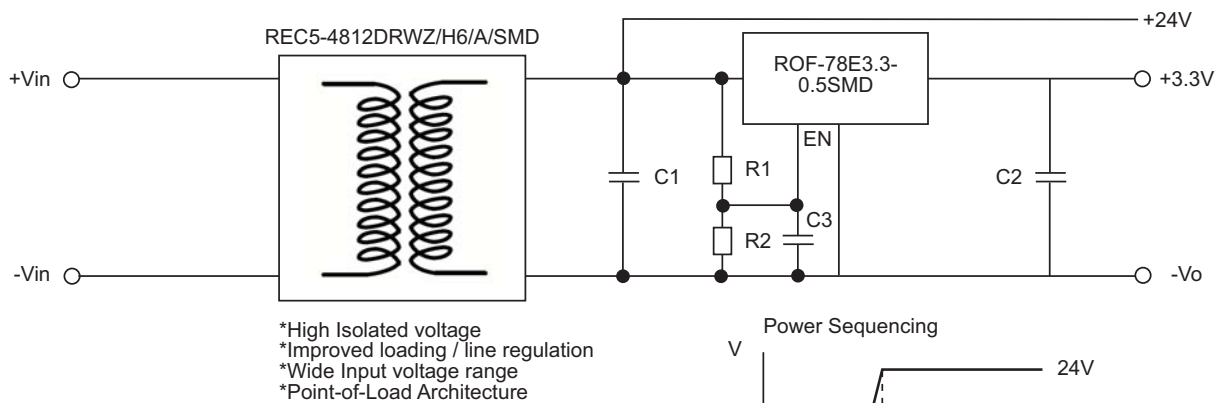

Optional Protection Circuit

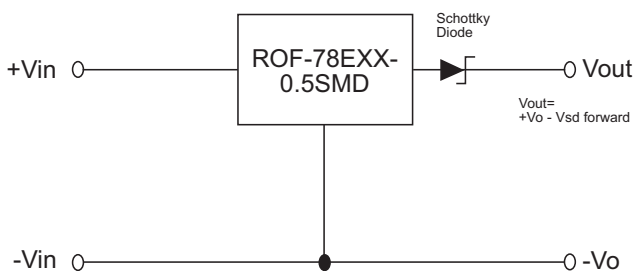

Add a blocking diode to Vout if current can flow backwards into the output, as this can damage the converter when it is powered down.

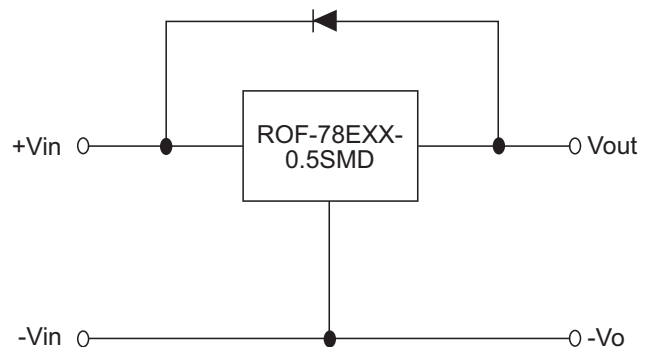

The diode can either be fitted across the device if the source is low impedance or fitted in series with the output.

Applications

Conduction / Radiation Emission Filter Suggestion

Suggestion for conduction Emission Class A, meet radiation emission Class B

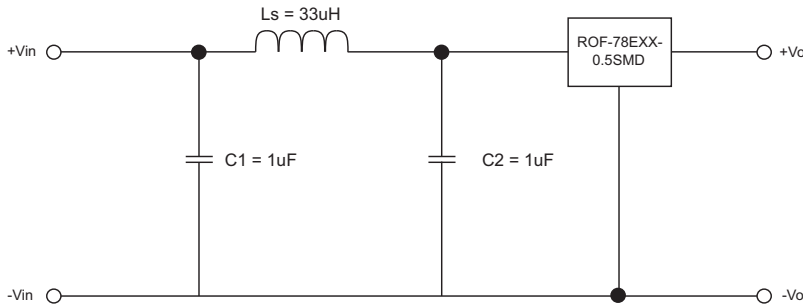

The capacitors used are ceramic capacitors, rated voltage 50V

Package Style and Pinning (mm)

ROF-78EXX-0.5SMD
Surface Mount Package

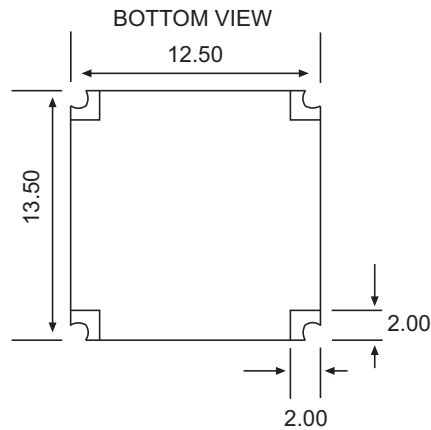
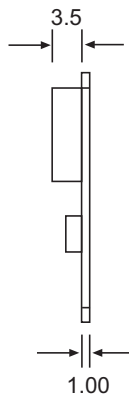
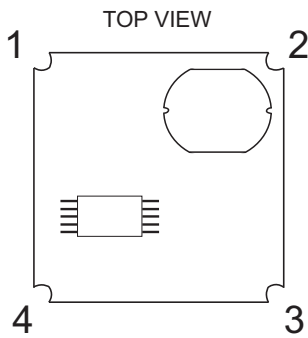

Recommended Footprint Details

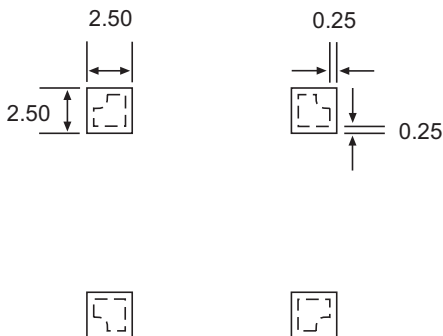

Pin Connections

Pin #	Out
1	+Vin
2	GND
3	+Vout
4	EN

XX.X ± 0.5 mm
XX.XX ± 0.25 mm

ROF-78E

Features

- Low Cost Switching Regulator
- High Startup current capability
- Efficiency up to 92 %
- Short Circuit Protection
- Pin Compatible with 78 Series Regulators
- 3.3V, 5V / 500 mA Output

Selection Guide

Part Number	Input Range (V)	Output Voltage (V)	Output Current (mA)	Efficiency (%)
R-78E5.0-0.5	7 - 28	5	500	82 - 92
R-78E3.3-0.5	6 - 28	3.3	500	75 - 88

Specifications (valid at nominal input voltage 24V full load after warm-up time unless otherwise states)

Input Voltage Range	5V Version	7 - 28 VDC
	3.3V Version	6 - 28 VDC
Output Voltage		5.0 VDC 3.3VDC
Output Current Range		5 - 500 mA
Output Voltage Accuracy		± 3% max.
Efficiency		see Table
Switching Frequency $V_{in} = 24V$		570 KHz typ.
Output Ripple & Noise @ 20MHz	at $V_{in} = 24 VDC, I_o = Full Load$	50mVp-p max.
Line Voltage Regulation		± 0.5 % max.
Load Voltage Regulation	10% to 100% Full Load	± 1 % max.
Short Circuit Protection		Automatic Restart
Operating Ambient Temperature Range (see Derating Graph)		-40°C - +85°C
Storage Temperature Range		- 55°C - +125°C
Packing Quantity		42 pcs per tube
Certifications		
EN General Safety	Report: SPCLVD 1301026-1	EN60950-1:2006 + A12:2011
MTBF (25°C)	MIL-HDBK-217F	4185 x 10 ³ hours
(75°C)	MIL-HDBT-217F	2182 x 10 ³ hours

Package Style and Pinning (mm)

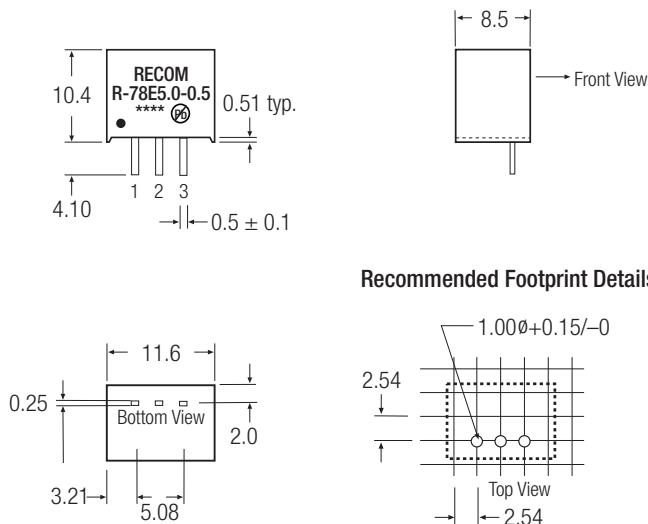

Recommended Footprint Details

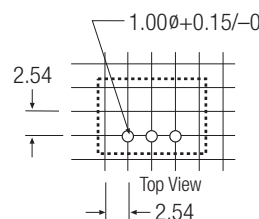

INNOLINE
DC/DC-Converter
with 3 year Warranty

RECOM

500mA
Single Output



EN-60950-1 Certified

R-78E-0.5

Derating-Graph (Ambient Temperature)

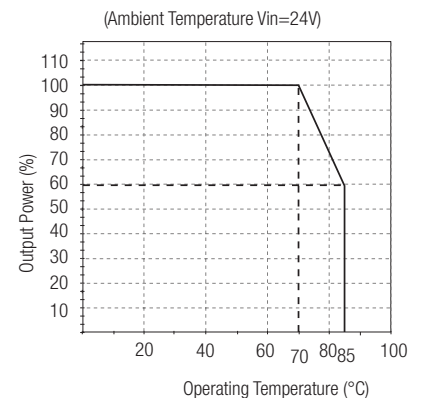

Refer to Application Notes

The product information and specifications are subject to change without prior notice. All products are designed for non-safety critical commercial and industrial applications. The Buyer agrees to implement safeguards that anticipate the consequences of any failures that might cause harm, loss of life and/or damage property.

Features

- Auto-sense
- Non-Isolated
- Synchronous rectification design
- Adjustable Output voltage
- 2, 3, 4 & 5AMP Adjustable Positive Step Down Integrated Switching Regulator
- Over load protection (125% full load typical)
- Remote ON/OFF Control(Ground Off)
- Wide Input Range
- UL94V-0 Package Material
- Continuous short circuit protection (Short Circuit Input Current, $I_{in\ sc} < 50mA$)
- Input voltage range 4.5V~18V
- Efficiency to 96 %

Description

The R-5XXX series is a high performance 1.2V to 5.0V , 2Amp to 5Amp, 12-Pin SIP (single in-line package) integrated switching regulator (ISR). Synchronous - rectified design yields excellent efficiencies up to 96%. Short circuit protection reduces the short circuit input current to under 50mA. Autosense function compensates for any losses in long circuit loops.

Selection Guide

Part Number SIP12	Input Range (V)	Nominal Output Voltage (V)	Vout Adjust Range (V)	Output Current (A)	Efficiency		
					min.Vin (%)	12V (%)	max.Vin (%)
R-521.2xA	4.5 – 18	1.2	1.0 – 3.0	2	83	79	75
R-521.8xA	4.5 – 18	1.8	1.1 – 4.5	2	88	85	82
R-522.5xA	4.5 – 18	2.5	1.6 – 5.5	2	91	88	86
R-523.3xA	4.5 – 18	3.3	1.6 – 5.5	2	92	90	89
R-525.0xA	6.5 – 18	5.0	3.0 – 5.5	2	95	93	92
R-531.2xA	4.5 – 18	1.2	1.0 – 3.0	3	85	84	82
R-531.8xA	4.5 – 18	1.8	1.1 – 4.5	3	89	88	86
R-532.5xA	4.5 – 18	2.5	1.6 – 5.5	3	92	91	89
R-533.3xA	4.5 – 18	3.3	1.6 – 5.5	3	94	93	92
R-535.0xA	6.5 – 18	5.0	3.0 – 5.5	3	96	95	94
R-541.2xA	4.5 – 18	1.2	1.0 – 3.0	4	82	81	79
R-541.8xA	4.5 – 18	1.8	1.1 – 4.5	4	87	86	85
R-542.5xA	4.5 – 18	2.5	1.6 – 5.5	4	91	89	88
R-543.3xA	4.5 – 18	3.3	1.6 – 5.5	4	93	92	91
R-545.0xA	6.5 – 18	5.0	3.0 – 5.5	4	95	94	93
R-551.2xA	4.5 – 18	1.2	1.0 – 3.0	5	81	80	78
R-551.8xA	4.5 – 18	1.8	1.1 – 4.5	5	86	85	84
R-552.5xA	4.5 – 18	2.5	1.6 – 5.5	5	90	89	88
R-553.3xA	4.5 – 18	3.3	1.6 – 5.5	5	92	91	90
R-555.0xA	7.0 – 18	5.0	3.0 – 5.5	5	94	93	92

Note: $V_{in} - V_{out} \geq 1.5V$ if adjust function is used!

Suffix x: (see mechanical drawing for details)

x = P pins vertical through hole

x = D pins bent for horizontal through hole mounting

INNOLINE
DC/DC-Converter
with 3 year Warranty

RECOM

2, 3, 4, 5 AMP
SIP12
Vertical &
Horizontal



EN-60950-1 Certified

R-5xxxA

Refer to Application Notes

Specifications (refer to the standard application circuit, Ta: 25°C)

Characteristics	Conditions	Min.	Typ.	Max.
Output Voltage Range	All Series	0.8		6.0V
Output Current	R-52xxPA/DA R-53xxPA/DA R-54xxPA/DA R-55xxPA/DA	0.2 0.3 0.4 0.5		2.0A 3.0A 4.0A 5.0A
Output Current Limit	R-52xxPA/DA R-53xxPA/DA R-54xxPA/DA R-55xxPA/DA		2.5 3.75 5.0 6.0	3.0A 4.25A 5.5A 6.5A
Short Circuit Input Current	All Series			50mA
Short Circuit Protection			Continuous, automatic recovery	
Output Voltage Accuracy	At 100% Load All Series		±1%	±2%
Line Voltage Regulation (Vin = min. to max. at full load)	R-52xxPA/DA R-53xxPA/DA & R-54xxPA/DA & R-55xxPA/DA		0.25 0.5	0.5% 1.0%
Load Regulation (10 to 100% full load)	R-52xxPA/DA R-53xxPA/DA & R-54xxPA/DA & R-55xxPA/DA		0.5 1.0	1.0% 2.0%
Ripple & Noise	R-52xxPA/DA R-53xxPA/DA & R-54xxPA/DA & R-55xxPA/DA		40mVp-p 80mVp-p	70mVp-p 120mVp-p
Transient Response (see note 1)	50% Load Change Vout Over / Undershoot		100µs	200µs 100mV
Remote ON / OFF (see note 2) (positive logic)	Open or High (Power ON) Low (Power OFF)	4.5		18V 0.8V
Remote Off Input Current	Remote ON/OFF low level			100µA
Max capacitance Load	with normal start-up time, no external diodes with <1 second start up time + diode protection circuit			300µF 6800µF
Switching Frequency		270	300	330kHz
Quiescent Current	Vin = min. to max. at 0% load			20mA
Operating Temperature Range		-40°C		+85°C
Storage Temperature Range		-40°C		+125°C
Case Material				Non-Conductive Black Plastic
Potting Material				Epoxy (UL94V-0)
Internal Power Dissipation	Io x Vo x (1-Efficiency)			1.4W
Package Weight				9g
Packing Quantity				15 pcs per Tube
MTBF (Nominal Vout, 100% load)	Tamb. = +25°C Tamb. = +85°C	} Detailed Information see Application Notes chapter "MTBF"		749 x 10 ³ hours 150 x 10 ³ hours
EN General Safety	Report: SPCLVD1301028-1			EN60950-1:2006 + A12:2011

Notes:

- Requires an electrolytic or tantalum output capacitor for proper operation in all applications (the capacitor to be placed as close as possible to the output pins)
100µF for R-52xxPA/DA, R-53xxPA/DA and R-54xxPA/DA or 220µF for R-55xxPA/DA.
- ON / OFF pin driven by TTL (logic gate), open-collector bipolar transistor or open-drain MOSFET.
- Output Current vs. Input Voltage (see graph below).

Output Current vs Input Voltage

How to calculate the max output current

The internal power dissipation(P_D)follows the equation:

$$P_D = I_o \times V_o \times (1-\eta)$$

$$I_o = P_D / V_o \times (1-\eta)$$

Where P_D = Internal power dissipation
I_o = Output current
V_o = Output voltage
η = Efficiency

Example: R-545.0P , at Vin = 18Vdc , Vo = 5Vdc , η=93% (see "Selection Guide" table)

(a) When Ta = 60°C , P_D = 1.4 Watt (see adjacent diagram)

$$I_o = 1.4(W) / 5(V) \times (1-0.93) = 4(A)$$

(b) When Ta = 85°C , P_D = 1 Watt (see adjacent diagram)

$$I_o = 1(W) / 5(V) \times (1-0.93) = 2.857(A)$$

(c) At Vin = 12Vdc efficiency = 94% (see "Selection Guide" table)

When Ta = 85°C , P_D = 1 Watt (see adjacent diagram)

$$I_o = 1(W) / 5(V) \times (1-0.94) = 3.33(A)$$

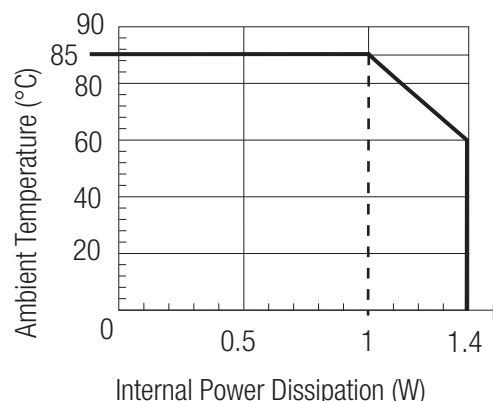

Standard Application Circuit

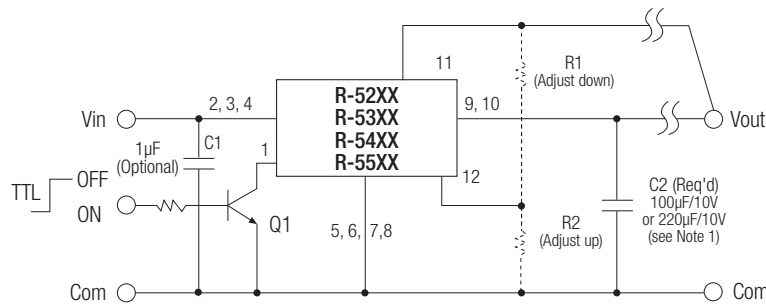

Add a blocking diode to Vout if current can flow backwards into the output, as this can damage the converter..

Parallel Application Circuit

The R-52xx, R-53xx, R-54xx series can be used in parallel to upgrade the output current capacity for the same output voltage.

For example, the R-543.3PA can parallel up with another R-554.3PA to give up to 8 amps or with the R-533.3PA or R-523.3PA types to give output currents of up to 7 Amps or 6 Amps.

The R-55xx series cannot be paralleled.

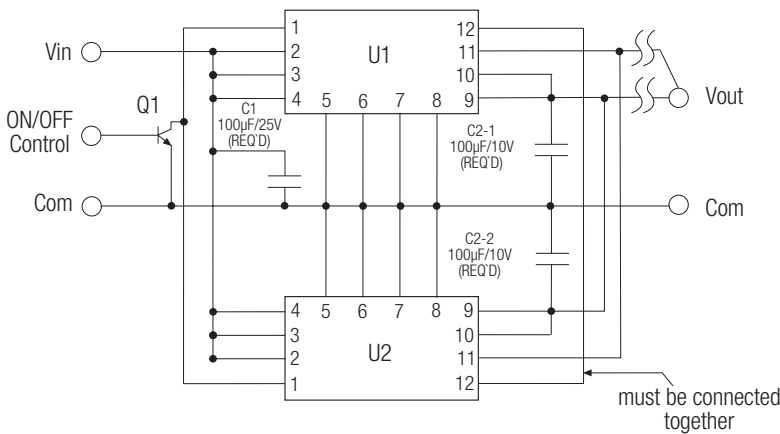

R-5xxxA

Component side

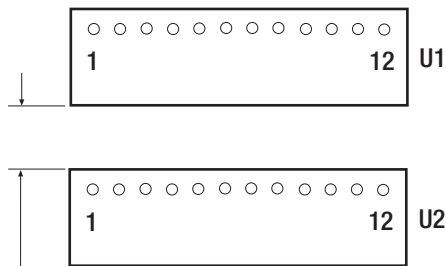

Keep 2mm to 5mm distance between both converters

Solder side

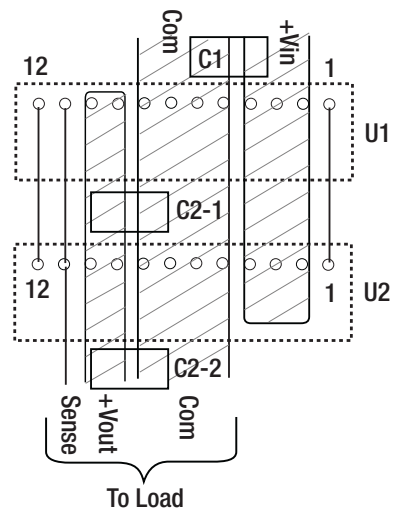

Characteristics

R-53xx / R-54xx
Output Voltage Line Regulation VS Vout

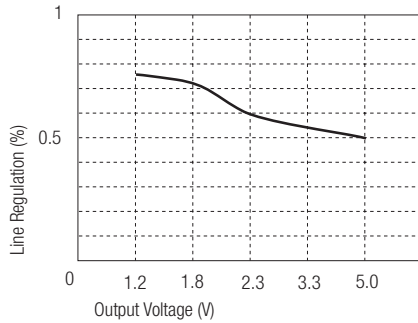

R-52xx / R-55xx
Output Voltage Line Regulation VS Vout

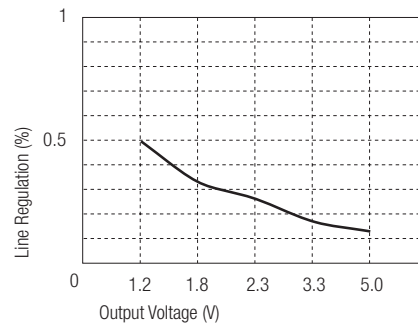

R-53xx / R-54xx
Input Voltage Load Regulation VS Vin

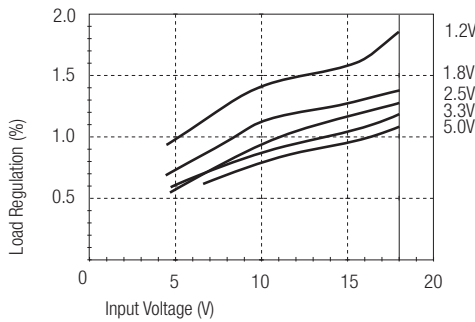

R-52xx / R-55xx
Input Voltage Load Regulation VS Vin

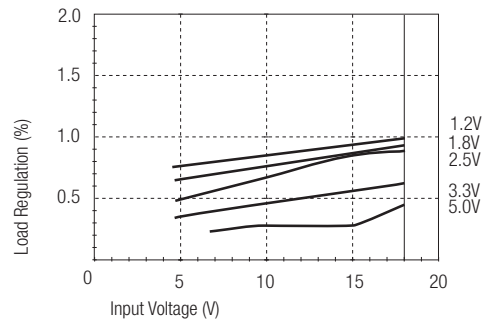

R-53xx / R-54xx / R-55xx
Output Current Efficiency vs I_{out} (Vin = Min)

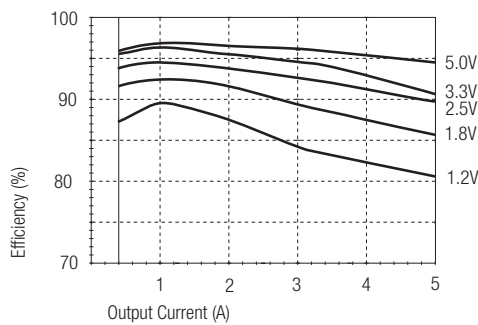

R-52xx
Output Current Efficiency vs I_{out} (Vin = Min)

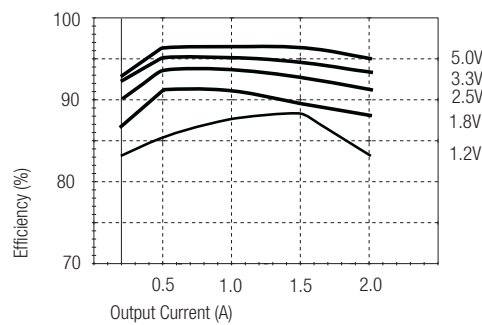

R-53xx / R-54xx / R-55xx
Output Current Efficiency vs I_{out} (Vin = 18V)

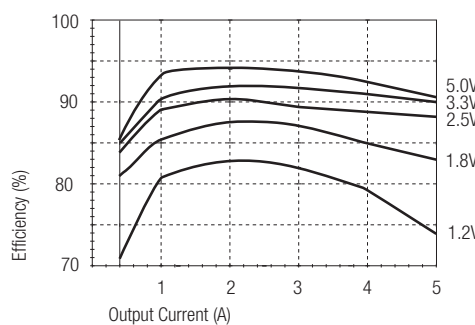

R-52xx
Output Current Efficiency VS I_{out} (Vin = 18V)

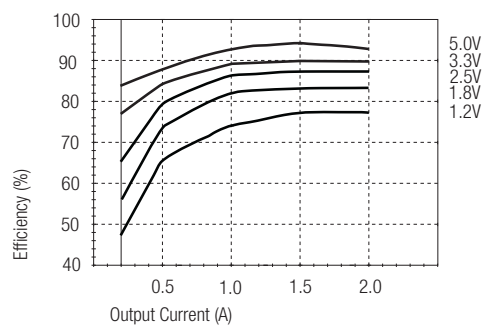

R-5xxxPA

Table 1: Adjustment Resistor Values

2Adc	R-521.2PA/DA		R-521.8PA/DA		R-522.5PA/DA		R-523.3PA/DA		525.0PA/DA	
3Adc	R-531.2PA/DA		R-531.8PA/DA		R-532.5PA/DA		R-533.3PA/DA		535.0PA/DA	
4Adc	R-541.2PA/DA		R-541.8PA/DA		R-542.5PA/DA		R-543.3PA/DA		545.0PA/DA	
5Adc	R-551.2PA/DA		R-551.8PA/DA		R-552.5PA/DA		R-553.3PA/DA		555.0PA/DA	
Vout (nominal)	1.2Vdc		1.8Vdc		2.5Vdc		3.3Vdc		5.0Vdc	
Vout (adj)	R1	R2	R1	R2	R1	R2	R1	R2	R1	R2
0.8 (V)										
0.9 (V)	740Ω									
1.0 (V)	3.9KΩ									
1.1 (V)	13KΩ		1.05KΩ							
1.2 (V)			2.1KΩ		270Ω					
1.3 (V)		37KΩ	3.7KΩ		750Ω					
1.5 (V)		11.5KΩ	10KΩ		2.1KΩ		390Ω			
1.6 (V)		8.2KΩ	18KΩ		3.0KΩ		750Ω			
1.7 (V)		6.5KΩ	41KΩ		4.1KΩ		1.2KΩ			
1.8 (V)		5.2KΩ			5.6KΩ		1.7KΩ			
1.9 (V)		4.3KΩ		36KΩ	7.5KΩ		2.2KΩ			
2.0 (V)		3.6KΩ		1.8KΩ	10.5KΩ		2.8KΩ			
2.4 (V)		2.1KΩ		5.2KΩ	82KΩ		6.8KΩ			
2.5 (V)		1.8KΩ		4.3KΩ			8.5KΩ			
2.6 (V)		1.65KΩ		3.6KΩ		33KΩ	10.5KΩ			
3.0 (V)		1.05KΩ		2.1KΩ		6.2KΩ	33KΩ		470Ω	
3.2 (V)				1.65KΩ		4.1KΩ	110KΩ		1.6KΩ	
3.3 (V)				1.5KΩ		3.4KΩ			2.2KΩ	
3.4 (V)				1.35KΩ		2.9KΩ		36KΩ	3.0KΩ	
3.6 (V)				1.07KΩ		2.2KΩ		11KΩ	4.7KΩ	
3.9 (V)				780Ω		1.4KΩ		4.7KΩ	8.5KΩ	
4.5 (V)				390Ω		650Ω		1.6KΩ	30KΩ	
4.9 (V)						350Ω		820Ω	220KΩ	
5.0 (V)						290Ω		680Ω		
5.1 (V)						220Ω		560Ω		28KΩ
5.5 (V)						39Ω		190Ω		2.6KΩ

R-5xxxA

Package Style and Pinning (mm)

SIP12 PIN Package

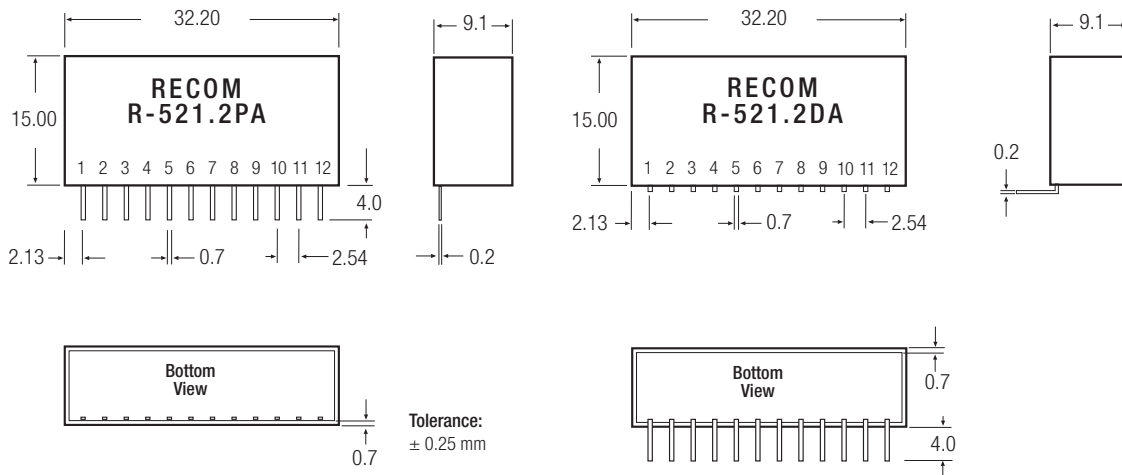

Pin Connections

Pin #	Name	Description
1	ON / OFF	Input pin : Active low (less than 0.8V) to disable the device
2, 3, 4	Vin	Power input
5, 6, 7, 8	GND	Input and output ground (common)
9, 10	Vout	Power output
11	Vout (Auto Sense)	If unused this pin must be connected to Pin 9 and 10
12	Vout-Adj	With external resistors R1,R2 to selected output voltage

R-5xxxPA

Optional Diode Protection Circuit

Optional Protection 1:

Add a blocking diode to Vout if current can flow backwards into the output, as this can damage the converter when it is powered down. Protection diodes are required for high capacitive loads.

The diode can either be fitted across the device if the source is low impedance or fitted in series with the output (recommended).

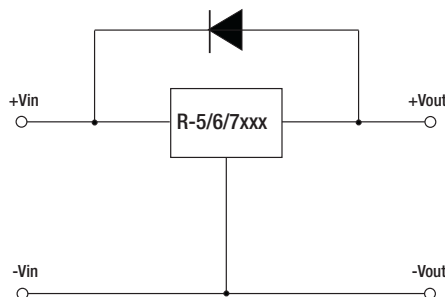

Optional Protection 2:

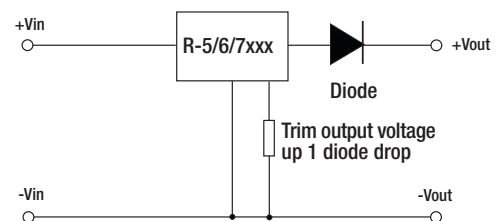

The product information and specifications are subject to change without prior notice. All products are designed for non-safety critical commercial and industrial applications. The Buyer agrees to implement safeguards that anticipate the consequences of any failures that might cause harm, loss of life and/or damage property.

Features

- Adjustable Output Voltage
- Non-Isolated
- 1-2AMP Adjustable Positive Step Down Integrated Switching Regulator
- Internal Short Circuit Protection
- ON/OFF Control(Ground Off)
- UL94V-0 Package Material
- Wide Input Range
- Efficiency to 96 %
- See InnoLine Application Notes for use as an inverter

Description

The R-6XXX series is a high performance 1.5V to 15V (18V), 1.1Amp to 2.0Amp, 12-Pin SIP (single in-line package) switching regulator. Synchronous rectification yields excellent efficiencies of up to 97%. Short circuit protection reduces the short circuit input current to under 50mA.

Selection Guide

Part Number SIP12	Input Range (V)	Nominal Output Voltage (V)	Vout Adjust Range (V)	Output Current (A)	Efficiency (%) Vin min. (%)	Vin max. (%)
R-611.8x	9 – 32	1.8	1.5 – 3.6	1	79	67
R-612.5x	9 – 32	2.5	1.5 – 4.5	1	84	74
R-613.3x	9 – 32	3.3	1.8 – 6	1	88	79
R-615.0x	9 – 32	5	1.8 – 9	1	92	84
R-619.0x	11 – 32	9	3.3 – 15	1	96	90
R-6112x	14 – 32	12	3.3 – 15	1	97	92
R-621.8x	9 – 32	1.8	1.5 – 3.6	2	76	68
R-622.5x	9 – 32	2.5	1.5 – 4.5	2	81	74
R-623.3x	9 – 32	3.3	1.8 – 6	2	86	80
R-625.0x	9 – 32	5	1.8 – 9	2	90	85
R-629.0x	11 – 32	9	3.3 – 15	2	95	91
R-6212x	14 – 32	12	3.3 – 15	2	96	93

Note: $V_{in} - V_{out} \geq 1.5V$ if adjust function is used!

Suffix x: (see mechanical drawing for details)

x = P pins vertical through hole

x = D pins bent for horizontal through hole mounting

Specifications (refer to the standard application circuit, Ta: 25°C)

Characteristics	Conditions	Min.	Typ.	Max.
Input Voltage Range	Vout = 1.8V	9V		32V
	Vout = 2.5V	9V		32V
	Vout = 3.3V	9V		32V
	Vout = 5V	9V		32V
	Vout = 9V	11V		32V
	Vout = 12V	14V		32V
	Vout = 18V	20V		32V
Output Voltage Adjust Range (see table 1)	Vout = 1.8V	1.5V	1.8V	3.6V
	Vout = 2.5V	1.5V	2.5V	4.5V
	Vout = 3.3V	1.8V	3.3V	6V
	Vout = 5V	1.8V	5V	9V
	Vout = 9V	3.3V	9V	15V
	Vout = 12V	3.3V	12V	15V
	Vout = 18V		18V	

Continued on next page

INNOLINE
DC/DC-Converter
with 3 year Warranty

RECOM

1-2 AMP
SIP12
Vertical &
Horizontal



EN-60950-1 Certified

R-6xxx

Refer to Application Notes

Specifications (refer to the standard application circuit, Ta: 25°C)

Characteristics	Conditions	Min.	Typ.	Max.
Output Current	R-61xxP/D R-62xxP/D	0.1A 0.2A		1.1A 2.0A
Output Current Limit		4A	4.5A	5A
Short Circuit Input Current	Vin > 12V	20mA		100mA
Short Circuit Protection		Continuous, automatic recovery		
Output Voltage Accuracy	At 100% Load		±1%	±2%
Line Voltage Regulation (Vin = min. to max. at full load)			0.5%	
Load Regulation (10 to 100% full load)	R-61xxP/D R-62xxP/D			0.5% 1.0%
Vo Ripple & Noise	R-61xxP/D R-62xxP/D		40mVpp 40mVpp	100mVpp 120mVpp
Transient Response (see note 1)	50% Load Change Vout Over / Undershoot		100us 5%	200us
Remote ON / OFF (see note 2) (positive logic)	Open or high (Power ON) Low (Power OFF)	2.0V		10V 0.8V
Remote Off Input Current	Remote ON/OFF low level		100µA	
Max capacitance Load	with normal start-up time, no external diodes with <1 second start up time + diode protection circuit			200µF 6800µF
Switching Frequency		200kHz	250kHz	300kHz
Quiescent Current	Vin = min. to max. at 0% load		6mA	10mA
Operating Temperature Range		-40°C		+85°C
Storage Temperature Range		-40°C		+125°C
Case Material		Non-Conductive Black Plastic		
Potting Material		Epoxy (UL94V-0)		
internal Power Dissipation	Io x Vo x (1-Efficiency)			1.0W
Package Weight				9g
Packing Quantity				15 pcs per Tube
MTBF (Nominal Vout, 100% load)	Tamb. = +25°C Tamb. = +71°C	} Detailed Information see Application Notes chapter "MTBF"		563 x 10³ hours 117 x 10³ hours
EN General Safety	Report: SPCLVD 1301028-1			EN60950-1:2006 + A12:2011

- Notes:**
- Requires a 100µF electrolytic or tantalum output capacitor for proper operation in all applications (the capacitor to be placed as close as possible to the output pins).
 - ON / OFF pin can be driven by TTL (logic gate), open-collector bipolar transistor or open-drain MOSFET.
 - Output Current vs. Input Voltage (see graph below).

Output Current vs Input Voltage

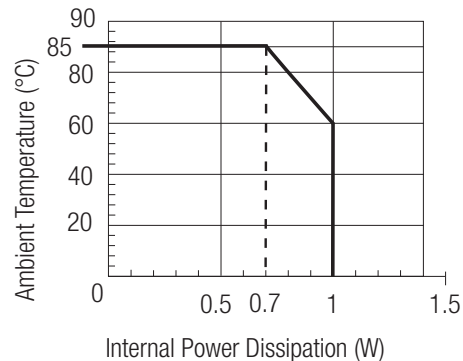
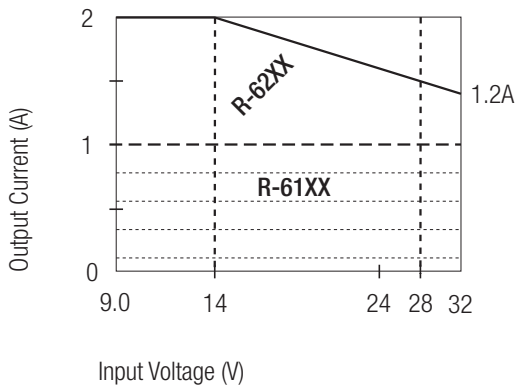

Max output current calculation:

Internal power dissipation
 $(1W) = I_o \times V_o \times (1 - \text{Efficiency})$
 $I_o = 1(W) / V_o \times (1 - \text{Efficiency})$

Example : R-6212P

at Vin = 28VDC

Efficiency = 94% (see "Selection Guide" table)

$V_o = 12VDC$

$I_o = 1W / 12V \times (1 - 0.94) = 1.388A = 1.5A$

at Vin = 14VDC

Efficiency = 96% (see "Selection Guide" table)

$V_o = 12Vdc$

$I_o = 1W / 12V \times (1 - 0.96) = 2.08A$ (spec. = 2A max.)

Characteristics

R-623.3 / R-613.3
Efficiency vs Output Current

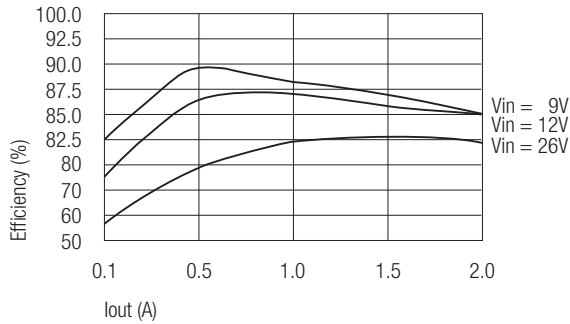

R-623.3 / R-613.3
Ripple vs Output Current

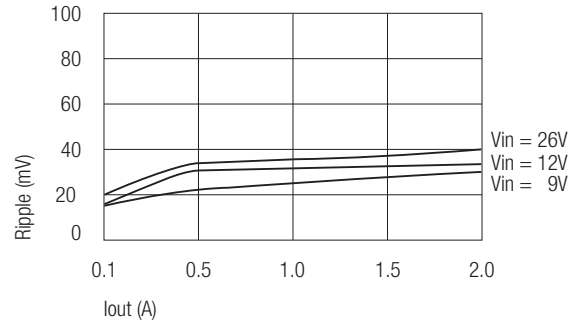

R-625.0 / R-615.0
Efficiency vs Output Current

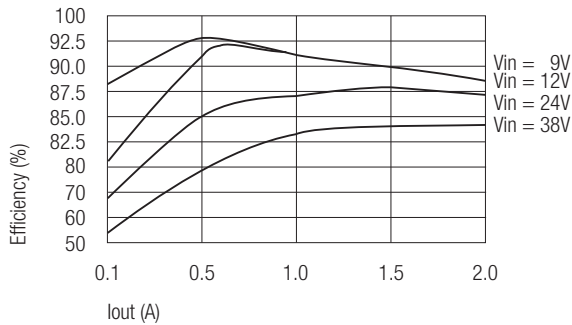

R-625.0 / R-615.0
Ripple vs Output Current

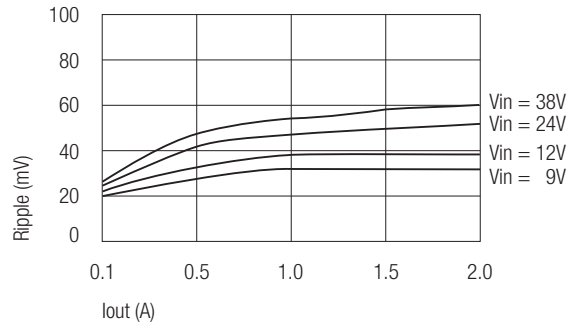

Package Style and Pinning (mm)

SIP12 PIN Package

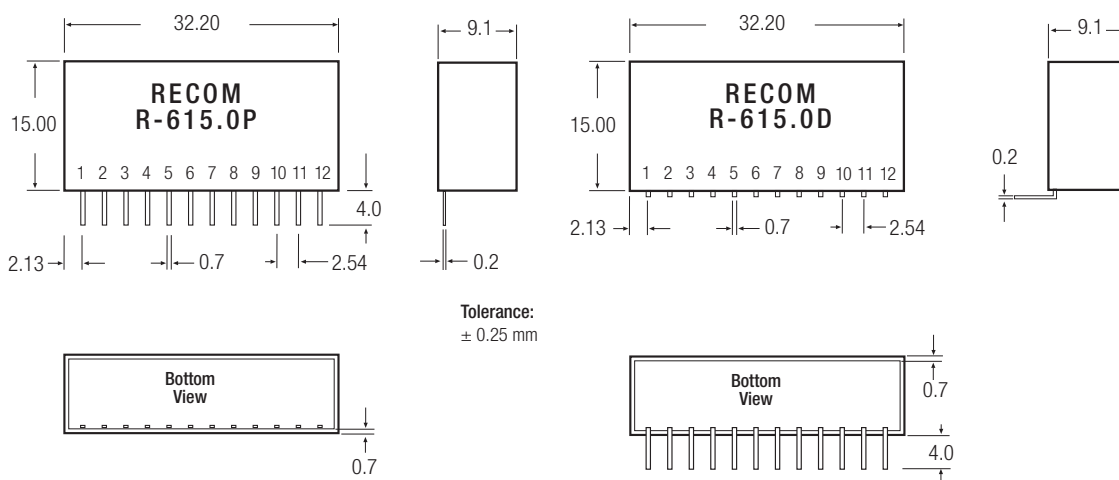

Tolerance:
± 0.25 mm

Pin Connections

Pin #	Name	Description
1	ON / OFF	Input pin : Active low (less than 0.8V) to disable the device
2, 3, 4	Vin	Power input
5, 6, 7, 8	GND	Input and output ground (common)
9, 10, 11	Vout	Power output
12	Vout-Adj	With external resistors R1,R2 to selected output voltage

Table 1: Adjustment Resistor Values

1.1Adc	R-611.8P/D		R-621.5P/D		R-613.3P/D		R-615.0P/D		R-619.0P/D		R-6112P/D	
2.0Adc	R-621.8P/D		R-622.5P/D		R-623.3P/D		R-625.0P/D		R-629.0P/D		R-6212P/D	
Vout (nominal)	1.8Vdc		2.5Vdc		3.3Vdc		5Vdc		9Vdc		12Vdc	
Vout (adj)	R1	R2	R1	R2	R1	R2	R1	R2	R1	R2	R1	R2
1.5	13.6KΩ		3.3KΩ									
1.8			8.2KΩ		3.1KΩ		820Ω					
2.0		10KΩ	15KΩ		5.1KΩ		1.5KΩ					
2.5		5.1KΩ			13KΩ		3.6KΩ					
3.0		2.5KΩ		10KΩ	51KΩ		7.0KΩ					
3.3		1.7KΩ		5.9KΩ			9.7KΩ		0Ω		0Ω	
3.6		1.2KΩ		3.9KΩ		18KΩ	14KΩ		1.5KΩ		560Ω	
3.9				2.8KΩ		9.1KΩ	20KΩ		3.3KΩ		1.2KΩ	
4.5				1.6KΩ		3.9KΩ	60KΩ		7.5KΩ		2.1KΩ	
5.0						2.4KΩ			11KΩ		4.0KΩ	
5.1						2.2KΩ		60KΩ	12KΩ		4.3KΩ	
5.5						1.6KΩ		15KΩ	17KΩ		5.6KΩ	
6.0						1.1KΩ		7.2Ω	24KΩ		7.5KΩ	
7.0								2.8KΩ	51KΩ		12KΩ	
8.0								1.5KΩ	130KΩ		19KΩ	
9.0								880Ω			31KΩ	
10								450Ω		36KΩ	55KΩ	
11								180Ω		15KΩ	125KΩ	
12										8.2KΩ		
13										4.7KΩ		11KΩ
14										2.7KΩ		4.0KΩ
15										1.3KΩ		1.6KΩ

R-6xxx

Standard Application Circuit

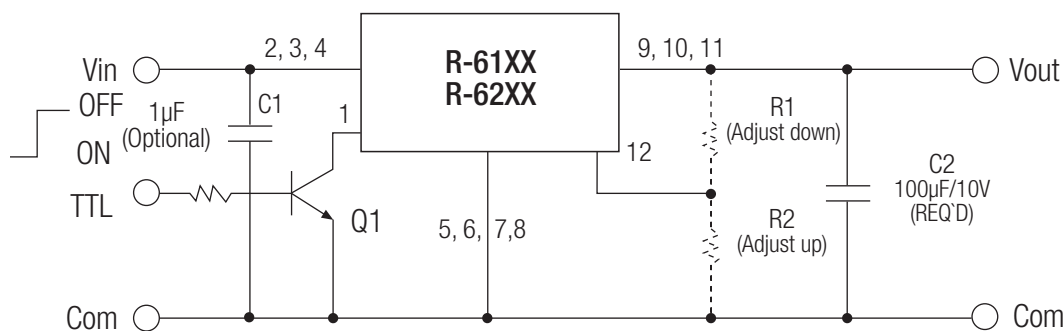

Add a blocking diode to Vout if current can flow backwards into the output, as this can damage the converter.

Protection diodes are required for high capacitive loads.

Refer to R-5xxxA Datasheet (see Optional Diode Protection Circuit) for circuit suggestions.

The product information and specifications are subject to change without prior notice. All products are designed for non-safety critical commercial and industrial applications. The Buyer agrees to implement safeguards that anticipate the consequences of any failures that might cause harm, loss of life and/or damage property.

Features

- Non-Isolated
- Synchronous rectification design
- Adjustable Output voltage
- 2, 3, 4AMP Adjustable Positive Step Down Integrated Switching Regulator
- Over load protection (125% full load typical)
- Remote ON/OFF Control(Ground Off)
- Wide Input Range
- UL94V-0 Package Material
- Continuous short circuit protection (Very low short current $I_{sc} < 50mA$)
- Input voltage range 4.5V~28V
- Efficiency to 97%

Description

The R-7XXX series is a high performance 2.5V to 15V , 2Amp to 4Amp, 12-Pin SIP (single in-line package), Integrated switching regulator (ISR). The Synchronous - rectified design yields excellent efficiencies up to 97%. Short circuit protection reduces the short circuit input current to under 50mA .

Selection Guide

Part Number SIP12	Input Range (V)	Nominal Output Voltage (V)	Vout Adjust Range (V)	Output Current (A)	Efficiency (%)		
					Min. Vin	12V	Max. Vin
R-723.3x	4.5 – 28	3.3	2.5 – 5.5	2	95	93	89
R-725.0x	6.5 – 28	5.0	3.0 – 5.5	2	96	95	91
R-726.5x	8.5 – 28	6.5	5.0 – 8.0	2	97	96	93
R-729.0x	12 – 28	9.0	7.0 – 11	2	96	-	93
R-7212x	15 – 28	12	10 – 14	2	97	-	95
R-7215x	19 – 28	15	13 – 17	2	97	-	96
R-733.3x	4.5 – 28	3.3	2.5 – 5.5	3	94	93	89
R-735.0x	6.5 – 28	5.0	3.0 – 5.5	3	95	95	92
R-736.5x	8.5 – 28	6.5	5.0 – 8.0	3	97	96	93
R-739.0x	12 – 28	9.0	7.0 – 11	3	96	-	94
R-7312x	15 – 28	12	10 – 14	3	97	-	96
R-7315x	19 – 28	15	13 – 17	3	97	-	96
R-743.3x	4.5 – 28	3.3	2.5 – 5.5	4	93	92	88
R-745.0x	6.5 – 28	5.0	3.0 – 5.5	4	95	94	91
R-746.5x	8.5 – 28	6.5	5.0 – 7.5	4	96	96	93

Note: $V_{in} - V_{out} \geq 1.5V - 4.0V$ depending on V_{out} if adjust function is used!

Suffix x: (see mechanical drawing for details)

x = P pins vertical through hole

x = D pins bent for horizontal through hole mounting

INNOLINE
DC/DC-Converter
with 3 year Warranty

RECOM

2, 3, 4 AMP
SIP12
Vertical &
Horizontal



EN-60950-1 Certified

R-7xxx

Refer to Application Notes

Specifications (refer to the standard application circuit, Ta: 25°C)

Characteristics	Conditions	Min.	Typ.	Max.
Output Voltage Range	All Series	2.5		17V
Output Current	R-72xxP/D R-73xxP/D R-74xxP/D	0.2 0.3 0.4		2.0A 3.0A 4.0A
Output Current Limit	R-72xxP/D R-73xxP/D R-74xxP/D		2.5 3.75 5.0	3.0A 4.25A 5.5A
Short Circuit Input Current	All Series		50	100mA
Short Circuit Protection		Continuous, automatic recovery		
Output Voltage Accuracy (At 100% Load)	All Series		±1%	±2%
Line Voltage Regulation (Vin = min. to max. at full load)	All Series		0.5	1.0%
Load Regulation (10 to 100% full load)	All Series		0.5	1.0%
Ripple & Noise	All Series		40mVp-p	70mVp-p
Transient Response (see note 1)	50% Load Change – Vout Over / Undershoot		100µs	200µs 100mV
Remote ON / OFF (see note 2)	Open or High (Power ON) Low (Power OFF)	4.5		28V 0.8V
Max capacitance Load	with normal start-up time, no external diodes with <1 second start up time + diode protection circuit			200µF 6800µF
Switching Frequency		270	300	330kHz
Shutdown current	ON / OFF Pin pulled low			100µA
Quiescent Current	Vin = min. to max. at 0% load			30mA
Operating Temperature Range		-40°C		+85°C
Operating Case Temperature				+110°C
Storage Temperature Range		-40°C		+125°C
Case Material		Non-Conductive Black Plastic		
Potting Material		Epoxy (UL94V-0)		
Thermal Impedance	Natural Convection			25°C/W
Internal Power Dissipation	Ta < 60°C			1.4W
Package Weight				9g
Packing Quantity				15 pcs per Tube
MTBF (Nominal Vout, 100% load)	Tamb. = +25°C Tamb. = +85°C	} Detailed Information see Application Notes chapter "MTBF"		749 x 10 ³ hours 150 x 10 ³ hours
EN General Safety	Report: SPCLVD1301028-1			EN60950-1:2006 + A12:2011

Notes:

- Requires a 100µF electrolytic or tantalum output capacitor for proper operation in all applications (the capacitor to be placed as close as possible to the output pins).
- ON / OFF pin driven by TTL (logic gate), open-collector bipolar transistor or open-drain MOSFET.

Output Current vs Input Voltage

How to calculate the max output current

The internal power dissipation(P_D)follows the equation:

$$P_D = I_o \times V_o \times (1-\eta)$$

$$I_o = P_D / V_o \times (1-\eta)$$

Where P_D = Internal power dissipation
I_o = Output current
V_o = Output voltage
η = Efficiency

Example: R-745.0P, at Vin = 28Vdc, Vo = 5Vdc, η=91% (see "Selection Guide" table)

(a) When Ta = 60°C, P_D = 1.4 Watt (see beside diagram)

$$I_o = 1.4(W) / 5(V) \times (1-0.91) = 3.11(A)$$

(b) When Ta = 85°C, P_D = 1 Watt (see beside diagram)

$$I_o = 1(W) / 5(V) \times (1-0.91) = 2.222(A)$$

(c) At Vin = 12Vdc efficiency = 94% (see "Selection Guide" table)

When Ta = 85°C, P_D = 1 Watt (see beside diagram)

$$I_o = 1(W) / 5(V) \times (1-0.94) = 3.33(A)$$

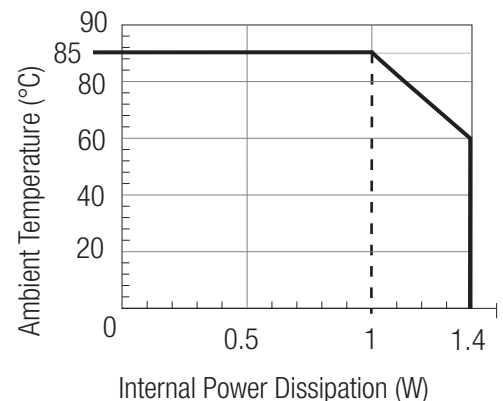

Characteristics

R-72xx / R-73xx
Ripple VS Vin

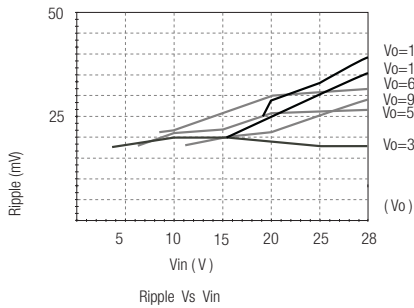

R-74xx
Ripple VS Vin

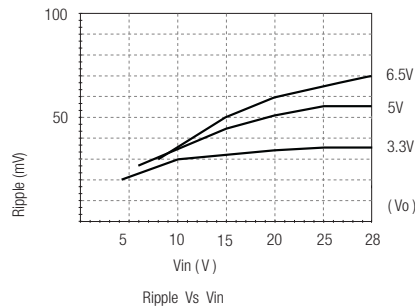

R-72xx / R-73xx
Efficiency VS Vin

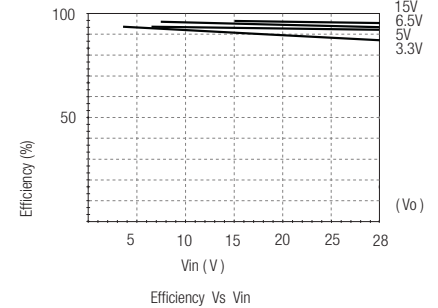

R-74xx
Efficiency VS Vin

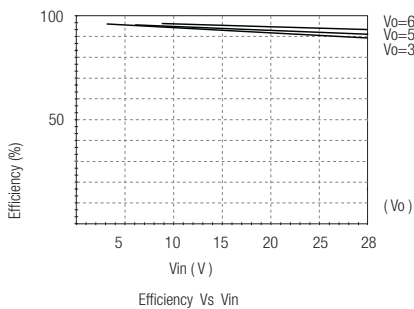

R-72xx / R-73xx / R-74xx
Efficiency / Load Vin=Min

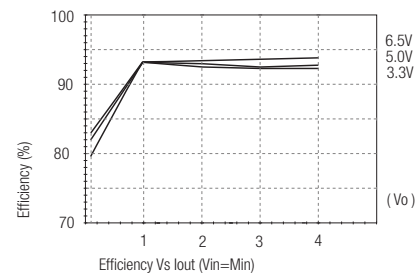

R-72xx / R-73xx / R-74xx
Efficiency / Load Vin=Max

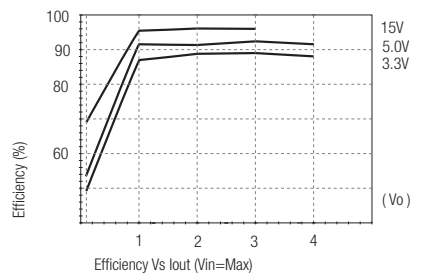

Package Style and Pinning (mm)

SIP12 PIN Package

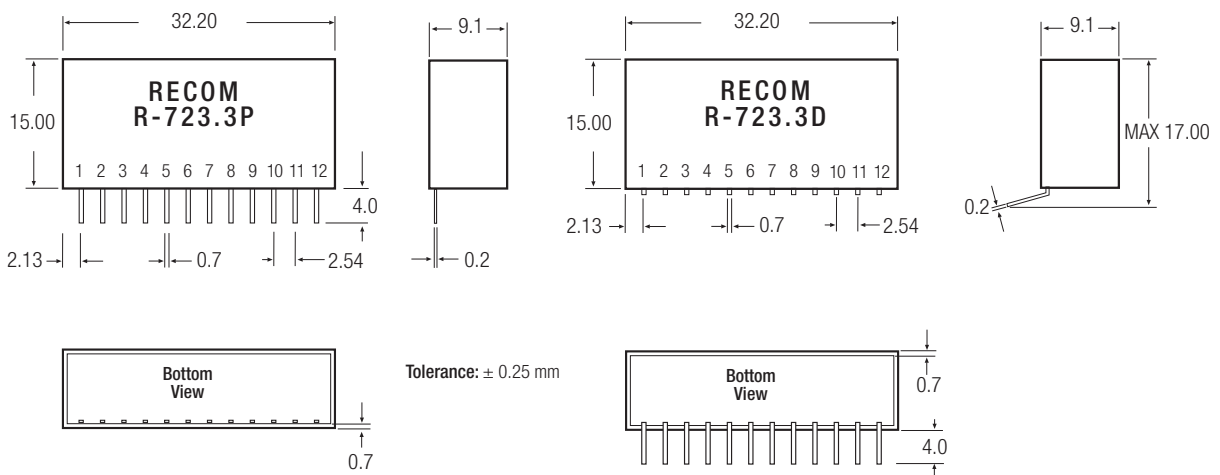

Pin Connections

Pin #	Name	Description
1	ON / OFF	Input pin : Active low (less than 0.8V) to disable the device
2, 3, 4	Vin	Power input
5, 6, 7, 8	GND	Input and output ground (common)
9, 10, 11	Vout	Power output
12	Vout-Adj	With external resistors R1,R2 to selected output voltage

Table 1: Adjustment Resistor Values

2ADC	R-723.3P/D	R-725.0P/D	R-726.5P/D	R-729.0P/D	R-7212P/D	R-7215P/D						
3ADC	R-733.3P/D	R-735.0P/D	R-736.5P/D	R-739.0P/D	R-7312P/D	R-7315P/D						
4ADC	R-743.3P/D	R-745.0P/D	R-746.5P/D									
Vout (nominal)	3.3Vdc		5.0Vdc		6.5Vdc		9.0Vdc		12Vdc		15Vdc	
Vout (adj)	R1	R2	R1	R2	R1	R2	R1	R2	R1	R2	R1	R2
2.5	8.5KΩ											
3.0	33KΩ		470Ω									
3.2	110KΩ		1.6KΩ									
3.3			2.2KΩ									
3.4		36KΩ	3.0KΩ									
3.6		11KΩ	4.7KΩ									
3.9		4.7KΩ	8.5KΩ									
4.5		1.6KΩ	30KΩ									
4.9		820Ω	220KΩ									
5.0		680Ω			11KΩ							
5.1		560Ω		28KΩ	12KΩ							
5.5		190Ω		2.6KΩ	20KΩ							
6.0					47KΩ							
6.5												
7.0						560Ω	13KΩ					
8.0						330Ω	31KΩ					
9.0												
10								2.2KΩ	20KΩ			
11								390Ω	47KΩ			
12												
13										2.4KΩ	36KΩ	
14										390Ω	76KΩ	
15												
16												2.6KΩ
17												860Ω
18												

R-7xxx

Standard Application Circuit

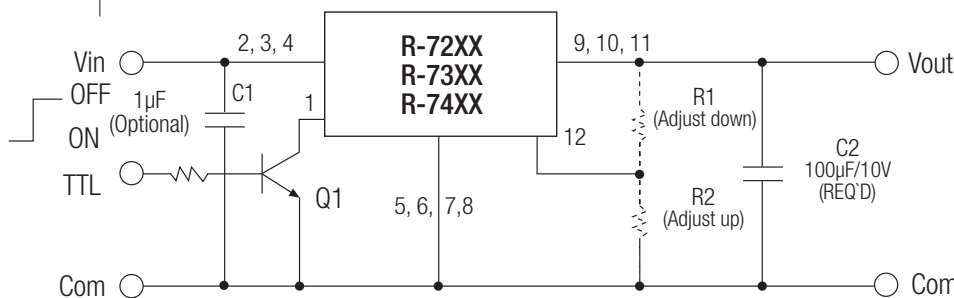

Add a blocking diode to Vout if current can flow backwards into the output, as this can damage the converter.

Protection diodes are required for high capacitive loads.

Refer to R-5xxxA Datasheet (see Optional Diode Protection Circuit) for circuit suggestions.

The product information and specifications are subject to change without prior notice. All products are designed for non-safety critical commercial and industrial applications. The Buyer agrees to implement safeguards that anticipate the consequences of any failures that might cause harm, loss of life and/or damage property.

Features

Regulated Converters

- High Output Voltage DIP24 converter
- Improved Version of Rxx-100_150A Series with higher efficiency and reduced ripple.
- Input Voltage 5, 12, 15 or 24VDC
- Adjustable Output Voltage up to 210VDC
- Cascadeable for Output Voltages up to 420VDC
- 3kVDC Input/Output Isolation
- Remote Voltage Programming by External Voltage or Resistance
- Continuous Short Circuit Protection
- Ambient Temperature up to +85°C

Selection Guide

Part Number DIP 24	Input Range (VDC)	Output Voltage Range (VDC)	Max Output Current (mA)	Efficiency at Full Load (%)
R05-100B	5 (4.5 – 6)	+40...+120	25	77
R12-100B	12 (10 – 14)	+55...+135	50	82
R15-100B	15 (14 – 17)	+55...+135	50	82
R24-100B	24 (21 – 27)	+55...+135	50	84
R12-150B	12 (10 – 14)	+95...+210	50	82
R15-150B	15 (14 – 17)	+95...+210	50	82
R24-150B	24 (21 – 27)	+95...+210	50	84

Specifications (typical at 25°C, nominal input voltage, full load unless otherwise specified)

Input Voltage Range		5, 12, 15 or 24VDC
Rated Power	5V	25mA max. or 3 Watts max.
	All others	50mA max. or 5 Watts max.
Output Voltage Adjustment Range		55..135 or 95..210VDC
Output Voltage Accuracy		±5% max
Line Voltage Regulation		0.5% max
Load Voltage Regulation	20% to 100% full load	0.5% max
Output Ripple and Noise	20MHz limited	60mVp-p typ.
Operating Frequency		200kHz typ.
Efficiency at Full Load		80 ~ 86% typ.
Isolation Voltage (tested for 1 second)		3000VDC min.
Isolation Capacitance		20pF typ.
Isolation Resistance		1 GΩ min.
Short Circuit Protection		Continuous, Automatic Restart
Short Circuit Input Current		30mA typ.
Temperature Coefficient		±0.02%/°C
Operating Temperature Range (free air convection)	With derating	-40°C to +85°C
	Full Power	-40°C to +70°C
Storage Temperature Range		-50°C to +125°C
Case Material		Non-Conductive Black Plastic
Potting Material		Epoxy (UL94V-0)
MTBF (25°C)	Mil-Std 217F	1400 x 10 ³ hours
Output Voltage Adjust	External Voltage	0 - 4VDC
	External Resistor	0 - 5kΩ
Internal Voltage Reference		Regulated 5V with 1kΩ series resistor
EN General Safety	Report: SPCLVD 1207005	EN60950-1:2006 + A12:2011

INNOVATION
DC/DC-Converter
with 3 year Warranty

RECOM

**5 Watt
Single
Output**

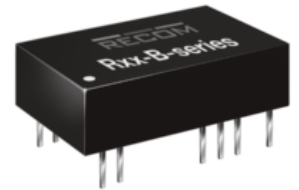

EN-60950-1 Certified

Rxx-B

**Derating Graph
(Ambient Temperature)**

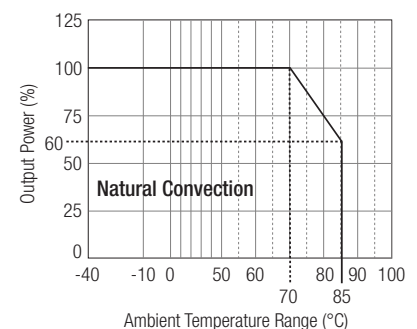

Refer to Application Notes

Typical Applications

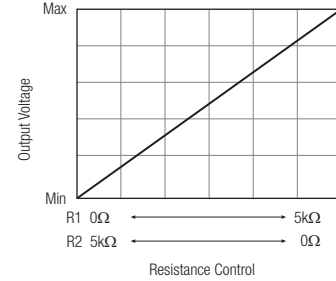
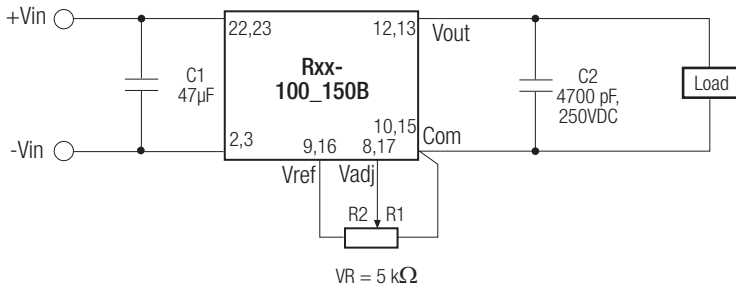

For remote voltage control

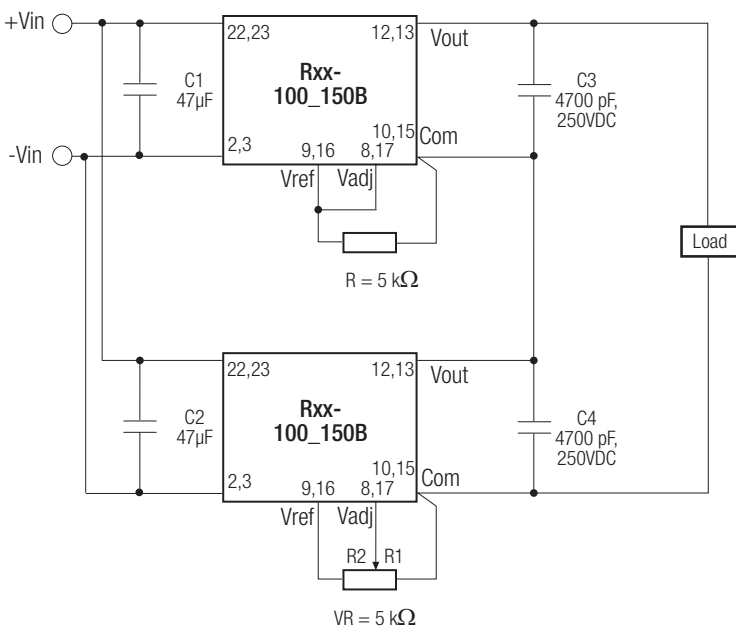
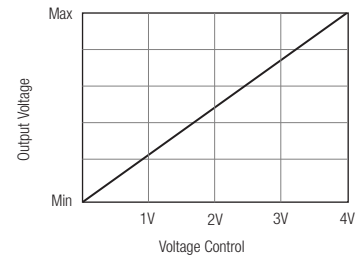
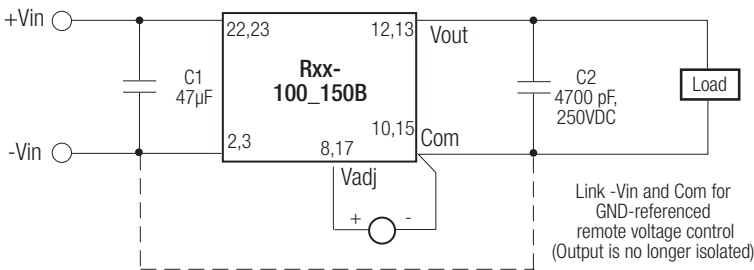

Cascade Combinations

U1	U2	Vout Range
R05-100B	R05-100B	160-240
Rxx-100B	Rxx-100B	190~270
Rxx-150B	Rxx-100B	230~345
Rxx-150B	Rxx-150B	305~420

xx = 12, 15 or 24

Note: When cascaded, only one Rxx-A may be adjustable, the other must be fixed voltage.

Typical Characteristics

R24-100B _ R24-150B

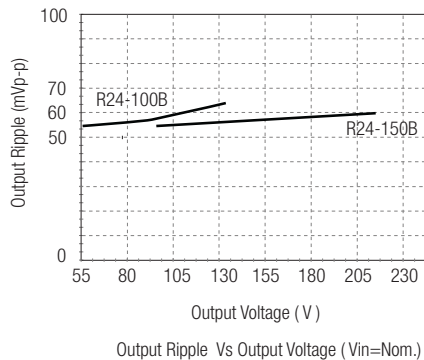

R24-100B _ R24-150B

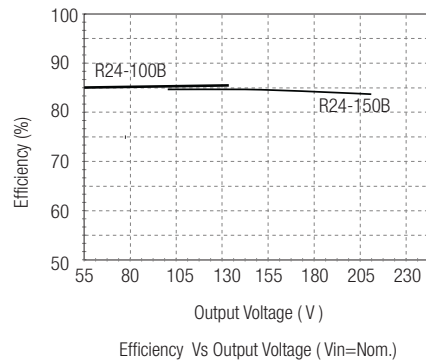

Power Limit

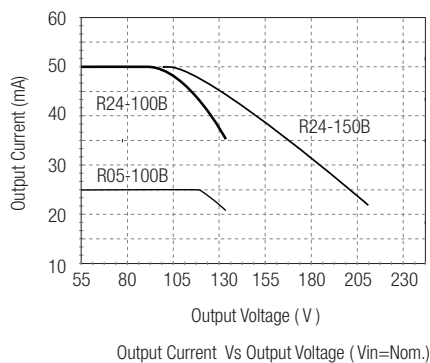

Rxx-B

Package Style and Pinning

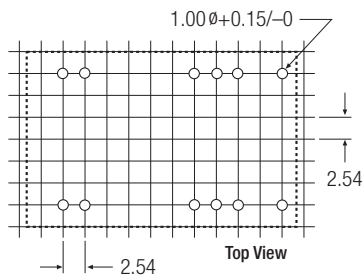
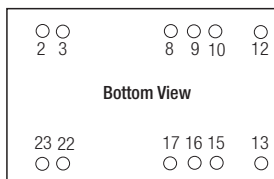
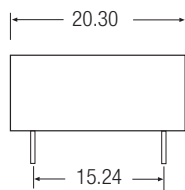
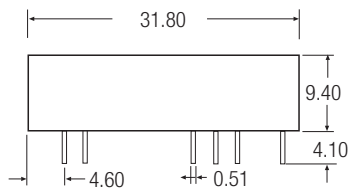

Pin Connections

Pin #	Out
2,3	-Vin
8,17	Vadj
9,16	V ref
10,15	-Vout
12,13	+Vout
22,23	+Vin
XX.X	± 0.5 mm
XX.XX	± 0.25 mm

The product information and specifications are subject to change without prior notice. All products are designed for non-safety critical commercial and industrial applications. The Buyer agrees to implement safeguards that anticipate the consequences of any failures that might cause harm, loss of life and/or damage property.

LIGHTLINE - DC/DC and AC/DC Constant Current LED Drivers

LIGHTLINE - CONTENTS

CONSTANT CURRENT LED DRIVERS



DC/DC Constant Current LED Drivers

Series	Current Limit	Input Voltage	Power/Type	Dimming	Mounting/Connections	Page
RCD-24-0.30 (Vref)	300mA	4.5 – 36VDC	10W Buck	Ana + PWM	DIP/Wired	L-3
RCD-24-0.35 (Vref)	350mA	4.5 – 36VDC	12W Buck	Ana + PWM	DIP/Wired	L-3
RCD-24-0.50 (Vref)	500mA	4.5 – 36VDC	17.5W Buck	Ana + PWM	DIP/Wired	L-3
RCD-24-0.60 (Vref)	600mA	4.5 – 36VDC	21W Buck	Ana + PWM	DIP/Wired	L-3
RCD-24-0.70 (Vref)	700mA	4.5 – 36VDC	25W Buck	Ana + PWM	DIP/Wired	L-3
RCD-24-1.00	1000mA	6 – 40VDC	33W Buck	Ana + PWM	DIP/Wired	L-3
RCD-24-1.20	1200mA	6 – 40VDC	40W Buck	Ana + PWM	DIP/Wired	L-3
RCD-24-0.30/PL	300mA	4.5 – 36VDC	10W Buck	Ana + PWM	Pinless SMD	L-9
RCD-24-0.35/PL	350mA	4.5 – 36VDC	12W Buck	Ana + PWM	Pinless SMD	L-9
RCD-24-0.50/PL	500mA	4.5 – 36VDC	17.5W Buck	Ana + PWM	Pinless SMD	L-9
RCD-24-0.60/PL	600mA	4.5 – 36VDC	21W Buck	Ana + PWM	Pinless SMD	L-9
RCD-24-0.70/PL	700mA	4.5 – 36VDC	25W Buck	Ana + PWM	Pinless SMD	L-9
RCD-48	350, 500, 700, 1200mA	9 – 60VDC	70W B	Ana + PWM	DIP/Wired	L-12
RBD-12	350 or 500mA	8 – 36VDC	1 – 20W Buck	Ana + PWM	DIP/Wired	L-16

AC/DC Constant Current LED Drivers

RACD03	350, 700mA	Universal AC	3W Isolated	None	Wired	L-19
RACD06	350, 700mA	Universal AC	6W Isolated	None	Screw Terminals	L-21
RACD07	350, 500, 700mA	Universal AC	7W Isolated	None	Wired	L-23
RACD12	350, 500, 700mA	Universal AC	12W Isolated	None	Screw Terminals, Socket	L-25
RACD20	350, 500, 700, 1050mA	Universal AC	20W Isolated	None	Screw Terminals, Socket	L-27
RACD20/277	350, 500, 700, 1050mA	Universal AC	20W Isolated	None	Wired	L-29
RACD20-350D	350+350 or 700mA	230VAC	20W Isolated	1-10VDC	Screw Terminals	L-31
RACD20-350D-US	350+350 or 700mA	115VAC	20W Isolated	1-10VDC	Screw Terminals	L-31
RACT20	350, 500, 700, 1050mA	Universal AC	20W Isolated	Triac Dimming F.	Wired	L-33
RACD25-P	500, 700, 1050, 1400mA	Universal AC	25W Isolated	None	Wired	L-35
RACV25	520	Universal AC	25W Isolated	None	Wired	L-37
RACD30	500, 700mA	Universal AC	30W Isolated	None	Screw Terminals, Socket	L-39
RACV30	1250, 2500mA	Universal AC	30W Isolated	None	Screw Terminals, Socket	L-41
RACD45-A	700, 1050, 1250, 1850	Universal AC	45W Isolated	Triac Dimming F.	Wired	L-42
RACD60-700/1050	700mA - 1050mA	Universal AC	60W Isolated	/TOF (1-10VDC)	Screw terminals	L-44
RACD60-1400/2140	1400mA - 2140mA					
RACD60-2400	2150mA - 2500mA					
RACD60-4200	3570mA - 4200mA					
RACD60-I/P67	700, 1050, 1400mA	Universal AC	60W Isolated	None	Wired	L-46
RACD60-/IP67	2100, 2400, 4200mA					
RACD60-A	700, 1200, 1650, 2500, 4200	Unviersal AC	60W Isolated	Triac Dimming F.	Wired	L-48
RACD100	8300, 4200, 2800, 2100mA	Universal AC	100W Isolated	None	Wired	L-50
RACD100-ENEC	8300, 4200, 2800, 2100mA	Universal AC	100W Isolated	None	Wired	L-52
RACD100-A	1400, 700mA	Universal AC	100W Isolated	Ana + PWM	Wired	L-54
RACD150	11000, 6300, 4200, 3200	Universal AC	150W Isolated	None	Wired	L-56
RACD150-ENEC	11000, 6300, 4200, 3200	Universal AC	150W Isolated	None	Wired	L-58
RACD150-A	700, 1050, 1400A	Universal AC	150W Isolated	AnA + PWM	Wired	L-60

DALI Converter

Series	Input Voltage	Dimming	DALI Standards IEC62386	Page
RELI-DA01/R	Universal AC	Ana + PWM DC 0-10V / 1-10V	Part-102 Part-206	L-62

Application Notes

L-66

Features

Regulated Converters

- UL/ RAILWAYS Certified Constant Current LED Driver
- Wide Input and Output Voltage Range
- Digital PWM and Analogue Voltage Dimming
- Short Circuit Protected
- Pinned or Wired Versions
- IP67 rated for /W Version
- 96% Efficiency
- 5 year Warranty

Description

The RCD series is a step-down constant current source designed for driving high power white LEDs. Standard output currents available are 300mA, 350mA, 500mA, 600mA, 700mA, 1000mA and 1200mA to make this driver compatible with a wide range of LEDs applications. Despite its compact size, the RCD series is fully featured with very high efficiency, wide input voltage range, high ambient operating temperature and two means of dimming: PWM/digital control and analogue voltage dimming. Both dimming controls are independent and can be combined. The driver is also designed to be as reliable as the LEDs it is driving, even at the full operating temperature. Options include an IP67-rated wired version (/W) and a version with built-in reference output voltage (/Vref) to power sensors or for easy analogue dimming.

Selection Guide

Part Number	Input Range (VDC)	Output Current (mA)	Output Voltage (Vmin-Vmax)	Dimming Control	Options	Mounting Style
RCD-24-0.30 ^{(a)(b)}	4.5-36V	0-300	2-35	Digital + Analogue	Vref	Pins or Wired
RCD-24-0.35 ^{(a)(b)}	4.5-36V	0-350	2-35	Digital + Analogue	Vref	Pins or Wired
RCD-24-0.50 ^{(a)(b)}	4.5-36V	0-500	2-35	Digital + Analogue	Vref	Pins or Wired
RCD-24-0.60 ^{(a)(b)}	4.5-36V	0-600	2-35	Digital + Analogue	Vref	Pins or Wired
RCD-24-0.70 ^{(a)(b)}	4.5-36V	0-700	2-35	Digital + Analogue	Vref	Pins or Wired
RCD-24-1.00 ^(b)	6-36V	0-1000	3-31	Digital + Analogue		Pins or Wired
RCD-24-1.20 ^(b)	6-36V	0-1200	3-31	Digital + Analogue		Pins or Wired

^{(a)(b)} Standard is no suffix with PCB Pins.

^(a) Add suffix /Vref for pinned version with Vref output and analogue dimming

^(b) Add suffix /W for wired version without dimming control (four wires)

^(b) Add suffix /W/X1 for wired version with analogue dimming control (five wires)

^(b) Add suffix /W/X2 for wired version with PWM dimming control (five wires)

^(b) Add suffix /W/X3 for wired version with both analogue and PWM dimming controls (six wires)

^(a) Add suffix /W/Vref for wired version with Vref output and analogue dimming (six wires)

Specifications (typical at 25°C, nominal input voltage, rated output current unless otherwise specified)

Input Voltage (absolute maximum)	40VDC max	
Recommended Input Voltage	300mA-700mA	5V min. / 24V typ. / 36VDC max
	1000mA-1200mA	6V min. / 24V typ. / 36VDC max
Input Filter	Capacitor	
Output Current Accuracy (Vin = 24DC)	300mA-700mA	±1% typ, ±3% max.
	1000mA-1200mA	±2% typ, ±5% max.
Internal Power Dissipation	Worst case load of 5 LEDs	800mW max
Output Current Stability	Vin=36V, Vout =1-9 LEDs	±1% max
Output Ripple and Noise (20MHz BW)	300mA-700mA	150mVp-p max
Vin=36V, Vout =1-9 LEDs	1000mA-1200mA	300mVp-p max
Temperature Coefficient	-40°C to +85°C ambient	±0.015%/°C max
Maximum Capacitive Load	100µF	
Operating Frequency	300mA-700mA	210kHz min/ 250kHz typ/ 280kHz max
	1000mA-1200mA	350kHz min/ 450kHz typ/ 550kHz max
Efficiency at Full Load	96% max.	
Short Circuit Protection	Regulated at rated output current	

continued on next page

LIGHTLINE

DC/DC-Converter

with 5 year Warranty

RECOM

Constant Current LED Driver



E358085

EN-50121-3-2 Certified

EN-60950-1 Certified

UL-60950-1 Certified

RCD-24

Derating Graph (Ambient Temperature)

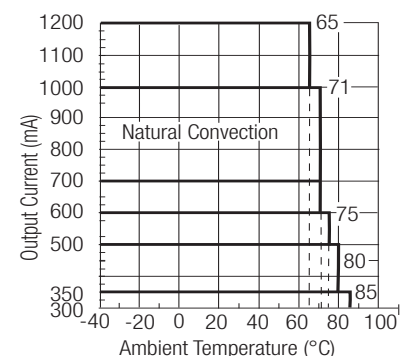

Refer to Application Notes

Specifications (typical at 25°C, nominal input voltage, rated output current unless otherwise specified)

Operating Temperature Range (free air convection)	300mA-350mA	-40°C to +85°C
	500mA	-40°C to +80°C
	600mA	-40°C to +75°C
	700mA-1000mA	-40°C to +71°C
	1200mA	-40°C to +65°C
Storage Temperature Range		-55°C to +125°C
Maximum Case Temperature		100°C
Thermal Impedance	Natural Convection	55°C/Watt
Case Material (Pinned or Wired Versions)	Non Conductive Black Plastic	
Potting Material (Pinned or Wired Versions)	Epoxy (UL94-V0)	
Dimensions	Pinned/Wired	22.1 x 12.6 x 8.5mm
Weight	Pinned/Wired	4.5g/6.8g
Soldering Profile	Pinned	265°C/10 sec. max
Packing Quantities (Refer to App Notes for Tube sizes)	Pinned Versions	39pcs per Tube
	Wired Versions	5pcs per Bag

PWM Dimming and ON/OFF Control (Leave open if not used - do not tie to +Vin)		
Remote ON/OFF	DC/DC ON	300mA-700mA Open or $0V < V_r < 0.6V$
Threshold Voltages	1000mA-1200mA	Open or $0V < V_r < 0.8V$
	DC/DC OFF (Standby)	300mA-700mA $0.6 < V_r < 2.9V$
	1000mA-1200mA	$1.4 < V_r < 2.2V$
	DC/DC OFF (Shutdown)	300mA-700mA $2.9V < V_r < 6V$
	1000mA-1200mA	$2.2V < V_r < 15V$
	Remote Pin Drive Current	$V_r = 5V$
Quiescent Input Current in Shutdown Mode	$V_{in} = 36V$	200µA max
Maximum PWM Frequency	For Linear Operation	200Hz max.
	Frequency Limit	1000Hz max.

Analogue Dimming Control (leave open if not used - do not tie to +Vin)		
Input Voltage Limits	Standard	-0.3V - 15V
	Vref Version	-0.3V - 5V
Control Voltage Range (see Graphs)	Full On	$0.13V \pm 50mV$
	300, 700, 1200mA: Full Off	$4.2V \pm 150mV$
	1000mA: Full Off	$4.35V \pm 100mV$
	Vref Version: Full Off	$2.6V \pm 100mV$
Analogue Pin Drive Current	$V_c = 5V$	0.2mA max.
Vref Version	Vref Voltage	$3.3V \pm 70mV$
	Vref Output Current	5mA
	Vref Output Short Circuit Current	18mA typ.

Environmental		
Relative Humidity	5% to 95% RH, non-condensing	
/W Versions	IP67	
Shock / Vibration	EN61373	
EMC Railways	EN50121-3-2:2006	
Conducted Emissions (with filter, see note)	EN55022	Class B
Radiated Emissions (all series except >700mA)	EN55022	Class B
ESD	EN61000-4-2	Class A
Radiated Immunity	EN61000-4-3	Class A
Fast Transient	EN61000-4-4	Class A
Conducted Immunity	EN61000-4-6	Class A
MTBF (RCD-24-0.70, Nominal Vin, Full Load) using MIL-HDBK 217F	+25°C	605×10^3 hours
	+71°C	516×10^3 hours

- Note:
- Requires an input filter to meet EN55022 Class B conducted emissions - see next page
 - All LED Drivers may not be used without a load. They must be switched on the primary side only. Noncompliance may damage the LED or reduce its lifetime.

Digital Dimming

PWM Digital Control Signal

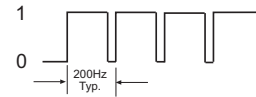

Output Current (LED appears dim)



PWM Digital Control Signal



Output Current (LED appears bright)



Analogue Dimming

Standard Version:

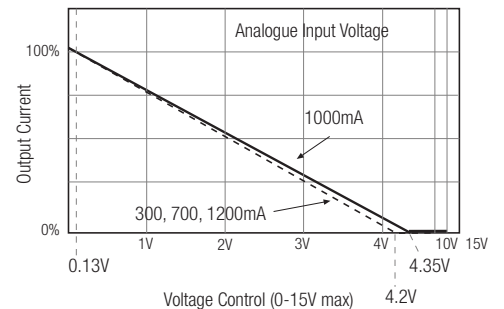

Vref Version:

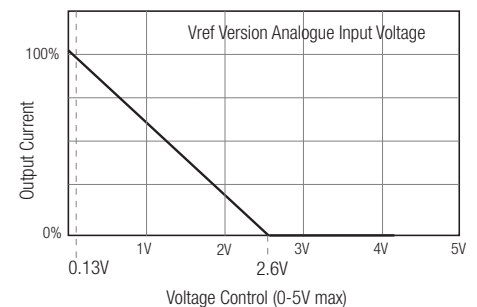

Combined PWM and Analogue Dimming

PWM Digital Control Signal

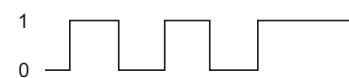

Output Current

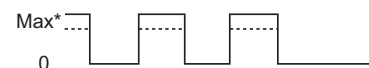

* Max output current can also be set using Analogue input

Typical Characteristics

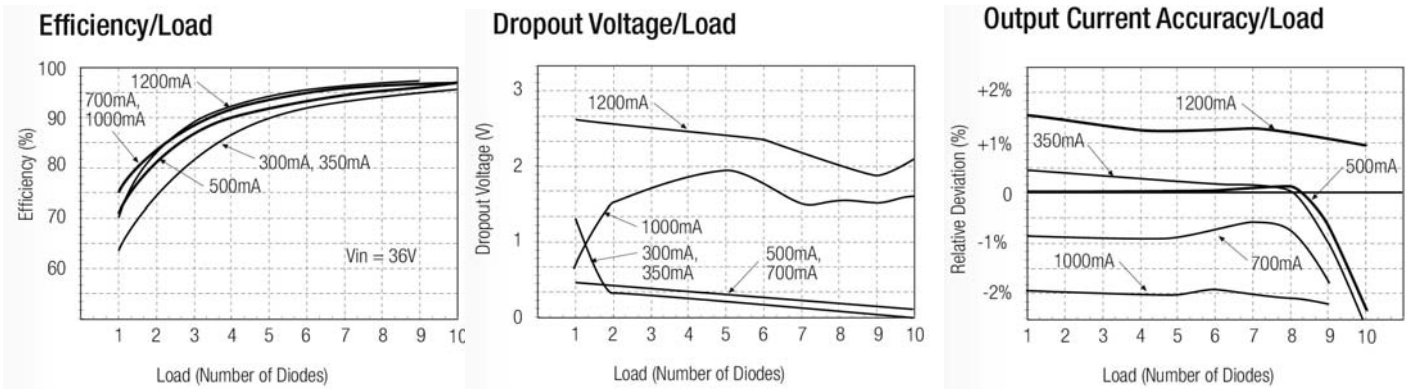

Standard Application Circuit (no external components required for normal use)

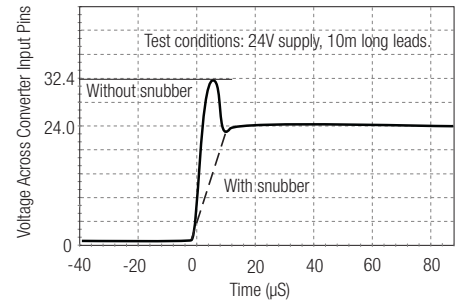
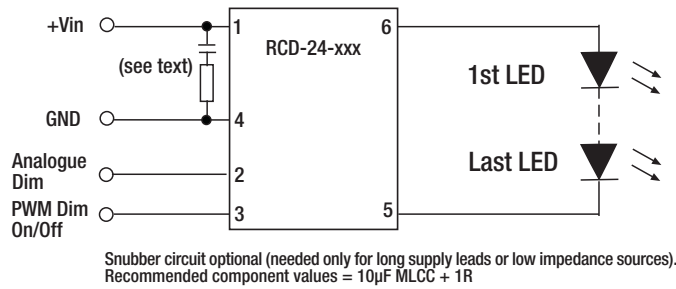

EMI Filter Suggestions

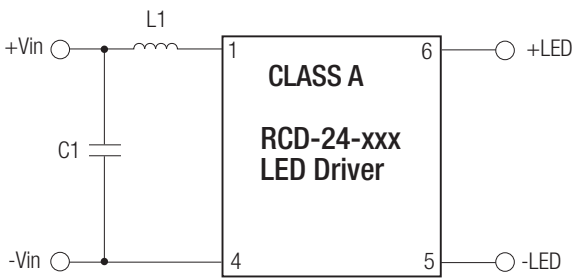

RCD-24-0.30 - RCD-24-0.70

$C1 = 1\mu F$ MLCC

$L1 = 22\mu H$

RCD-24-1.00 - RCD-24-1.20

$C1 = 2.2\mu F$ MLCC

$L1 = 47\mu H$

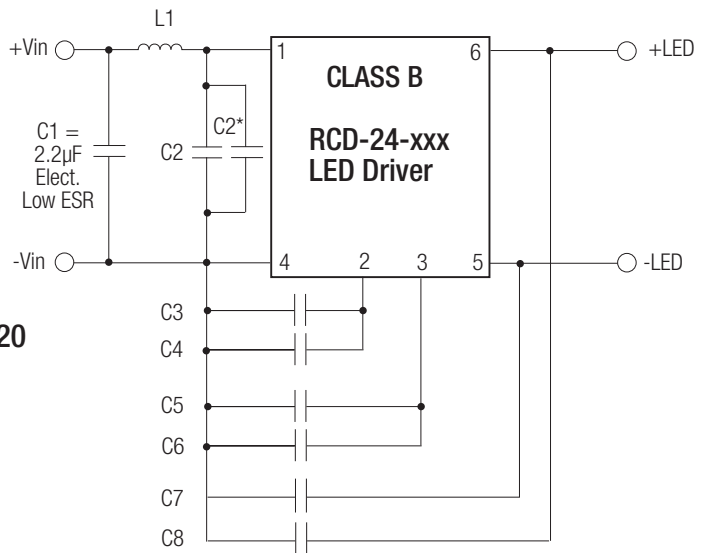

Recommended Class B PCB Layout for Pinned Version

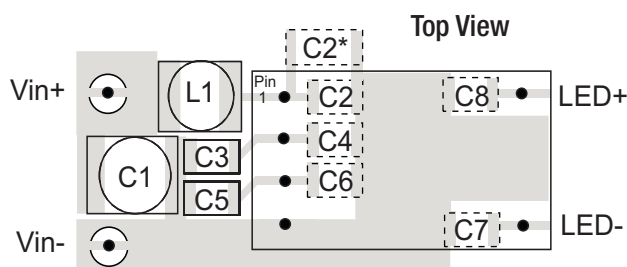

RCD-24-0.30 - RCD-24-0.70

No dimming or PWM dimming:

$L1 = 47\mu H$

$C2 = C3 = 10nF$ MLCC

Other caps not required

Analogue Dimming used:

$L1 = 120\mu H$

$C2 = C7 = 10nF$ MLCC

Other caps not required

RCD-24-1.00 - RCD-24-1.20

$L1 = 220\mu H$

$C2 = 10nF$

$C3 = C5 = 2.2nF$

$C4 = C6 = C7 = C8 = 100nF$

All capacitors MLCC

$C2^*$ = optional $2\mu F$ MLCC only if $L1$ starts to resonate with the back ripple current.

Application Examples

LED DRIVER with 0-10V Interface

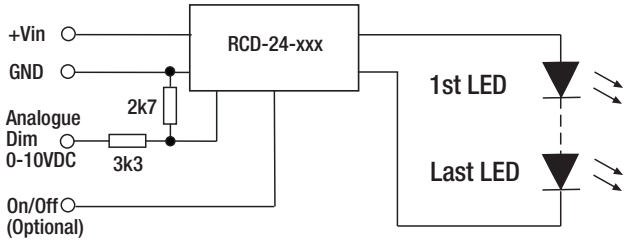

LED DIMMER for up to 10 white LEDs

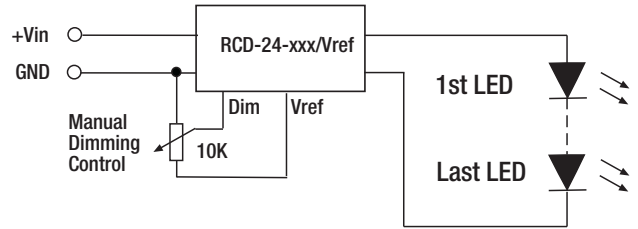

MULTIPLE LED DRIVER (up to 20 LEDs)

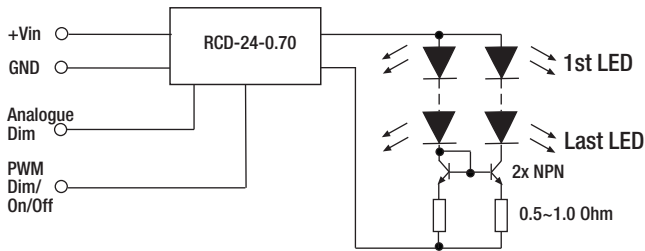

LED DIMMER with high frequency PWM control

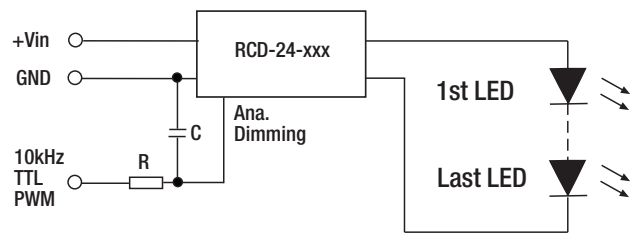

Driving Two Strings of 350mA LEDs with one 700mA Driver using a current mirror

Note:
It is not possible to parallel the drivers to increase the current.

LED Temperature Monitoring

Automatic LED Overtemperature Protection

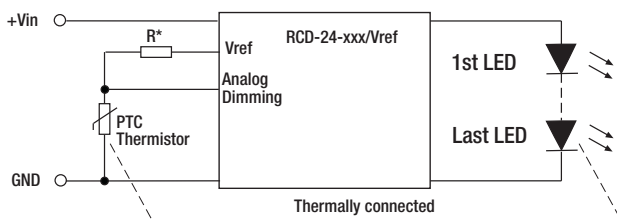

*Typically, choose R so that $R=R_{ptc} @ 85^{\circ}C$ and $R > 660 \Omega$.

Typical Response Curve (PTC = 500 Ohm @ 70°C)

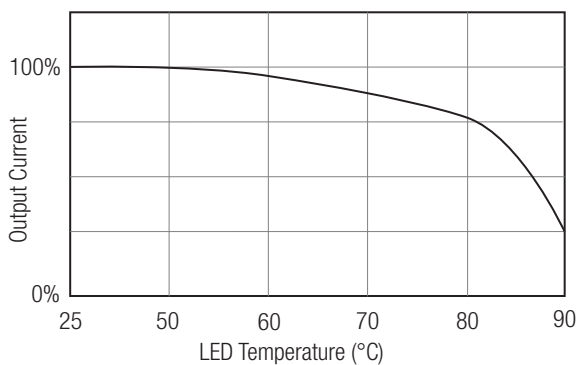

RGB Driver

SIMPLE RGB Mixer

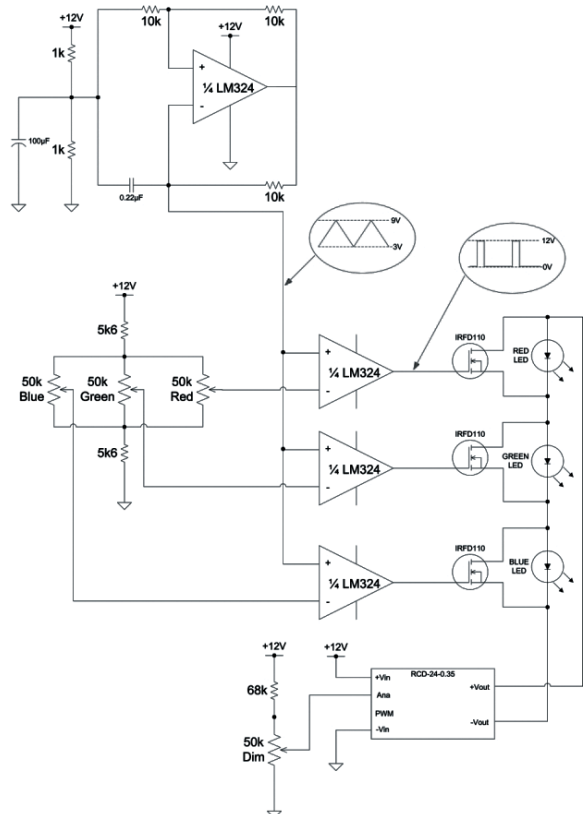

Package Style and Pinning

Pinned Version

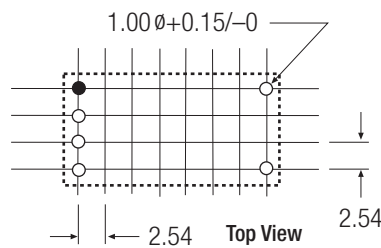
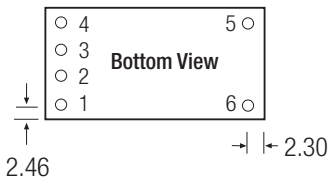
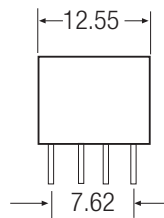
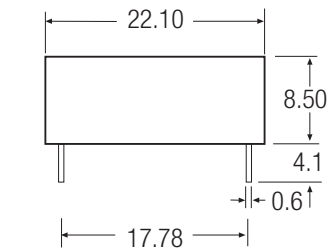

Recommended Footprint Details

Pin Connections		RCD-24 Series
Pin #	Out	Comments
1	+Vin	DC Supply
2	Analogue Dimming	Leave open if not used
3	PWM/ON/OFF	Leave open if not used
(3	Vref	Vref Version only)
4	GND	Do not connect to -Vout
5	-Vout	LED Cathode Connection
6	+Vout	LED Anode Connection

XX.X ± 0.5 mm
XX.XX ± 0.25 mm
Pin Tolerance ± 0.1 mm

Leave >1mm space around case on PCB for air circulation

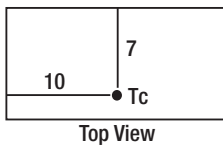

Wired Versions

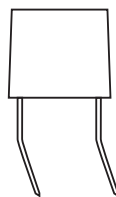
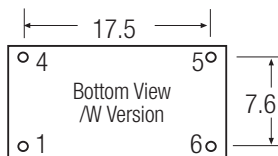

Wire Connections		RCD-24/W Series
Wire #	Function	Comments
1 (Red)	+Vin	DC Supply
4 (Black)	GND	Do not connect to -Vout
5 (Brown)	-Vout	LED Cathode Connection
6 (Yellow)	+Vout	LED Anode Connection

Wire length = 100mm + 10mm stripped & tinned = 110mm total
Wire outside diameter = 1.6mm
Wire core diameter = 0.75mm
Wire is UL/CSA listed/ 22AWG / 300V Rated

RCD-24

Package Style and Pinning

Wired Versions

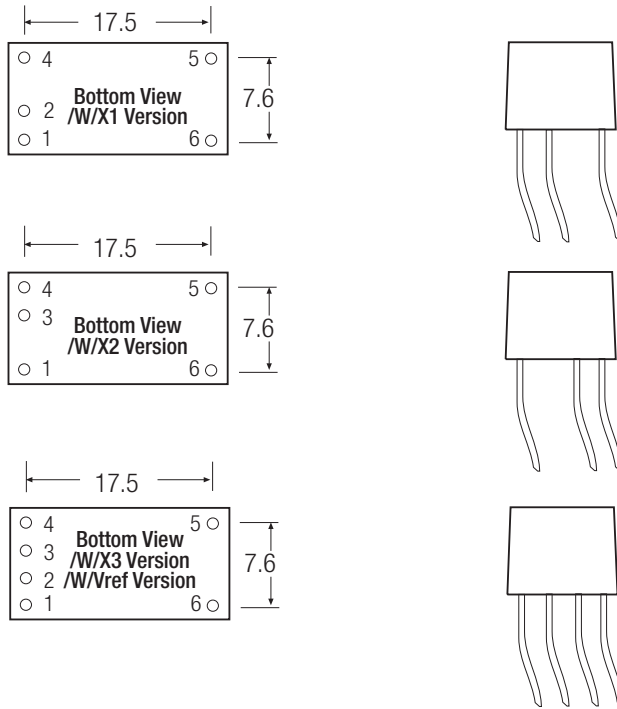

Wire Connections	RCD-24/W/X Series	
Wire #	Function	Comments
2 (Green)	Ana Dimming	/X1
3 (Blue)	PWM Dimming	/X2
2 + 3 (Green + Blue)	Ana + PWM Dimming	/X3
2 + 3 (Green + Yellow)	Ana Dimming + Vref	/Vref

Wire length = 100mm + 10mm stripped & tinned = 110mm total
 Wire outside diameter = 1.6mm
 Wire core diameter = 0.75mm
 Wire is UL/CSA listed/ 22AWG / 300V Rated

Wired Versions are packed in bags - 5pcs per bag.

Warning: Do not connect or disconnect the LED load while the converter is powered on. This may damage or reduce the lifetime of the LED.

Features

Regulated Converters

- SMD Constant Current LED Driver
- Built-in Class A or Class B EMC Filter
- Wide Input and Output Voltage Range
- Digital PWM and Analogue Voltage Dimming
- Short Circuit and Overtemperature Protected
- Low Cost
- EN/RAILWAYS Certified
- 5 Year Warranty

Description

The RCD-24-xxx/PL series is a step-down constant current source designed for driving high power LEDs. The converter uses a pinless SMD open frame design to reduce cost and size. Output currents available are 300mA, 350mA, 500mA, 600mA, 700mA and 1000mA with either Class A (Suffix /A) or Class B (suffix /B) built-in EMC filtering. Despite its compact size, the RCD-PL series is fully featured with very high efficiency, wide input voltage range, high ambient operating temperature and two means of LED dimming: PWM/digital control and analogue voltage dimming. Both dimming controls are independent and can be combined. The driver is also designed to be as reliable as the LEDs it is driving, even at the full ambient operating temperature and is designed for strip lighting, wall washers and fluorescent tube replacement designs, where a low profile and narrow width are demanded.

Selection Guide

Part Number	Input Range (VDC)	Output Current (mA)	Output Voltage (Vmin-Vmax)	Dimming Control	Mounting Style
RCD-24-0.30/PL*	4.5-36V	0-300	2-35	Digital + Analogue	Pinless SMD
RCD-24-0.35/PL*	4.5-36V	0-350	2-35	Digital + Analogue	Pinless SMD
RCD-24-0.50/PL*	4.5-36V	0-500	2-35	Digital + Analogue	Pinless SMD
RCD-24-0.60/PL*	4.5-36V	0-600	2-35	Digital + Analogue	Pinless SMD
RCD-24-0.70/PL*	4.5-36V	0-700	2-35	Digital + Analogue	Pinless SMD
RCD-24-1.00/PL/A	6-36V	0-1000	2-32	Digital + Analogue	Pinless SMD

* /A for EMC Class A input Filter add -R for Tape and Reel Packaging e.g. RCD-24-0.35/PL/B-R

* /B for EMC Class B input Filter

Note: RCD-24-1.00/PL/A only available with Class A Filter

Specifications (typical at 25°C, nominal input voltage, rated output current unless otherwise specified)

Input Voltage (absolute maximum)	40VDC max	
Recommended Input Voltage	6V min. / 24V typ. / 36VDC max	
Input Filter	Suffix /A Suffix /B RCD-24-1.00/PL/A	Capacitor Class B with Pi Filter Class A with Pi Filter
Output Current Accuracy (Vin=24V)	300-700mA 1000mA	±2% typ, ±3% max ±3% typ, ±5% max
Internal Power Dissipation	Worst case load of 5 LEDs (300-700mA) Worst case load of 8 LEDs (1000mA), Vin=36V	700mW max. 1.6W typ.
Output Current Stability	Vin = 36V, Vout = 1-9 LEDs (300-700mA) Vin = 36V, Vout = 1-8 LEDs (1000mA)	±1% max ± 1.5% max.
Output Ripple and Noise (20MHz BW)	Vin=36V, Vout = 1-9 LEDs (300-700mA) Vin=36V, Vout = 1-8 LEDs (1000mA)	300mVp-p max
Temperature Coefficient	-40°C to +85°C ambient ±0.015%/°C max	
Maximum Capacitive Load	100µF	
Operating Frequency	300-1000mA	212kHz min/ 250kHz typ/ 280kHz max
Efficiency at Full Load	300-700mA Vin=36V, Vout=8 LEDs (1000mA)	96% typ. 94% typ.
Short Circuit Protection	Regulated at rated output current	
Operating Temperature Range	300/350mA 500mA 600/700mA 1000mA	-40°C to +85°C -40°C to +80°C -40°C to +75°C -40°C to +65°C
Storage Temperature Range	-55°C to +125°C	
Relative Humidity	5% to 95% RH, non-condensing	

continued on next page

LIGHTLINE

DC/DC-Converter

with 5 year Warranty

RECOM

Constant Current LED Driver



E358085

EN-50121-3-2 Certified

EN-60950-1 Certified

UL-60950-1 Certified

RCD-24-PL

Derating Graph

(Ambient Temperature)

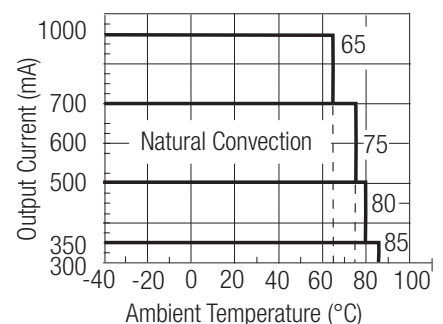

Refer to Application Notes

Specifications (typical at 25°C, nominal input voltage, rated output current unless otherwise specified)

Dimensions	31.0 x 11.4 x 6.6mm	
Weight	1.9g	
Packing Quantity	12 pcs per Tube / 400 pcs per Reel	
Reflow Soldering Profile	265°C/10 sec max	
MTBF	25°C	>600 khours
(using MIL HDBK 217F)		

PWM Dimming and ON/OFF Control (Leave open if not used)

Remote ON/OFF	DC/DC ON	Open or $0V < V_r < 0.6V$
Threshold Voltages	DC/DC OFF (Standby)	$0.6 < V_r < 2.9V$
	DC/DC OFF (Full Shutdown)	$2.9V < V_r < 6V$
Remote Pin Drive Current	$V_r = 5V$	1mA max
Quiescent Input Current in Shutdown Mode	$V_{in} = 36V$	200µA max
Recommended PWM Frequency (measured 10%~90% Dimming)	For Linear Operation	200Hz
	Maximum Frequency	1000Hz

Analogue Dimming Control (leave open if not used)

Input Voltage Range	300-1000mA	-0.3V - 15V
Control Voltage Range Limits (see Graph)	300-1000mA / Full On	$0.13V \pm 50mV$
	300-700mA / Full Off	$4.2V \pm 150mV$
	1000mA / Full Off	$4.35V \pm 100mV$
Analogue Pin Drive Current	300-1000mA / $V_c = 5V$	0.2mA max.

Environmental

Shock / Vibration	EN61373	
EMC Railways	EN50121-3-2:2006	
Conducted Emissions	300-1000mA (/A Suffix)	EN55022 Class A
	300-700mA (/B Suffix)	EN55022 Class B
Radiated Emissions	EN55022 Class B	
ESD	EN61000-4-2 Class A	
Radiated Immunity	EN61000-4-3 Class A	
Fast Transient	EN61000-4-4 Class A	
Conducted Immunity	EN61000-4-6 Class A	

Note:

- All LED Drivers may not be used without a load. They must be switched on the primary side only. Noncompliance may damage the LED or reduce its lifetime.
- It is not possible to parallel the drivers to increase the current.

Digital Dimming

PWM Digital Control Signal

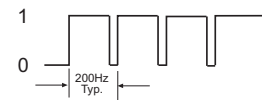

Output Current (LED appears dim)



PWM Digital Control Signal

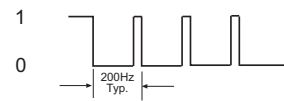

Output Current (LED appears bright)



Analogue Dimming

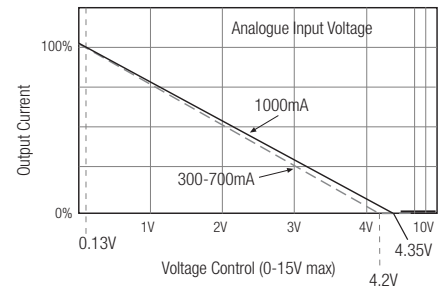

Typical Characteristics

$V_{in} = 24V, I_{out} = 300\sim 1000mA$

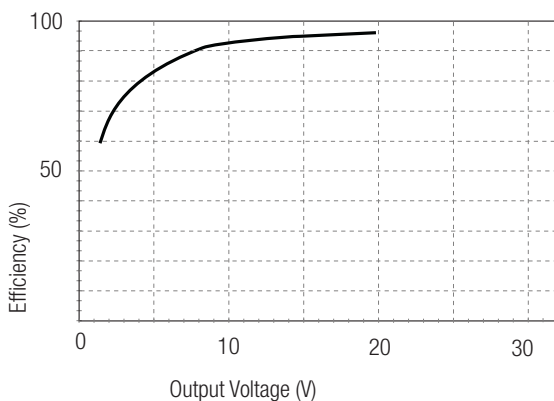

$V_{in} = 32V, I_{out} = 300\sim 1000mA$

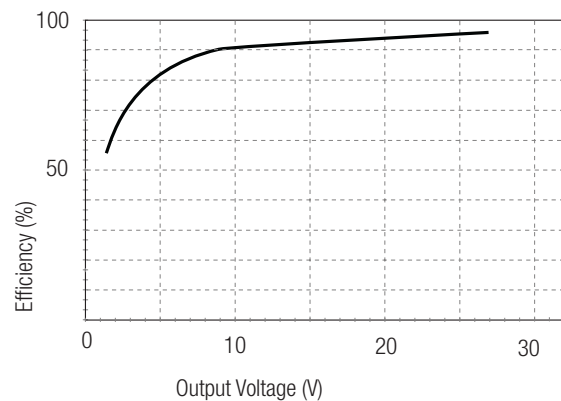

Package Style and Pinning

Class A Version

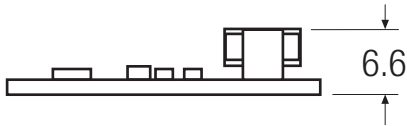

Class A (1.00A-Version)
Class B Version

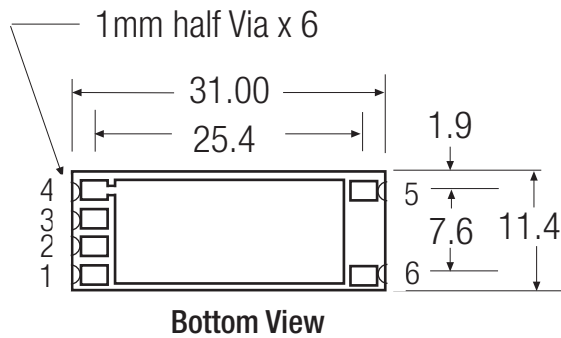

PCB Layout Top View

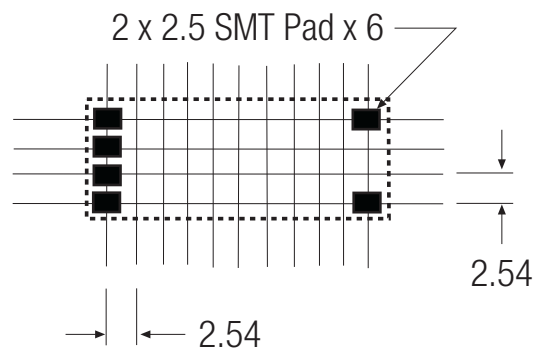

Pad Connections	RCD-24-PL Series	
Pad #	Out	Comments
1	+Vin	DC Supply
2	Analogue Dimming	Leave open if not used
3	PWM/ON/OFF	Leave open if not used
4	GND	Do not connect to -Vout
5	-Vout	LED Cathode Connection
6	+Vout	LED Anode Connection

XX.X ± 0.5 mm
XX.XX ± 0.25 mm

Features

LED DRIVER

- 70W Buck LED Driver
- Constant Current Output (350 to 1200mA)
- Digital PWM and Analogue Voltage Dimming
- High Efficiency to 96%
- EN, UL and RAILWAYS Certified
- Metal or Plastic Case Version
- IP67 Rated for /W, Plastic Case Version

Description

The RCD-48 series is a step-down constant current source designed for driving high power LED applications. Four output currents are available. The maximum output voltage is 56V. The buck drivers have digital PWM and/or analogue voltage dimming control and are special featured with very high efficiency. Typical applications are 48V bus lighting solutions or high voltage LED arrays (e.g. high bay lights).

Selection Guide

Part Number	Input Range (VDC)	Output Current (mA)	Output Voltage (VDC)	Dimming Control	Efficiency Typ. (%)
RCD-48-0.35*	9-60	0-350	2-56	Digital + Analogue	96
RCD-48-0.50*	9-60	0-500	2-56	Digital + Analogue	96
RCD-48-0.70*	9-60	0-700	2-56	Digital + Analogue	96
RCD-48-1.00*	9-60	0-1000	2-56	Digital + Analogue	96
RCD-48-1.20/M	9-60	0-1200	2-56	Digital + Analogue	96

*add suffix "/W" for wired version with Vref output and analogue + PWM dimming control (seven wires)

Note:

Add suffix "/M" for metal case (RCD-48-1.20/M only). No metal case with wires available.

Standard version (no suffix) and wired version (suffix /W) only in plastic case.

Specifications (typical at 25°C, nominal input voltage, rated output current unless otherwise specified)

Operating Input Voltage Range	9-60VDC	
Absolute Maximum Input Voltage	65VDC max.	
Output LED String Voltage Range (depend on the input voltage, defined by the output impedance, see Safe Operating Area)	2V min. / 56V max.	
Input Filter	Capacitor	
Output Current Accuracy	±3% typ. / ±5% max.	
Internal Power Dissipation (Vin=60V, Vout=56V)	350mA	0.8W typ.
	500mA	1.0W typ.
	700mA	1.1W typ.
	1000mA	1.3W typ.
	1200mA	1.4W typ.
Output Current Stability	Vin=60V, Vout=2-56V, Iout=350-1200mA	±1% max.
Output Ripple and Noise (20MHz BW)	Vin=60V, Vout=2-56V, Iout=350-1200mA	300mVp-p max.
Maximum Capacitive Load	100µF max.	
Switching Frequency	50kHz min. / 1000kHz max.	
Efficiency at Full Load	96% typ.	
PWM DIMMING CONTROL & REMOTE ON/OFF CONTROL		
Input Voltage Range	5V typ. / 10V max.	
Threshold Voltage	Device ON	0.5V max.
	Device OFF	2.0V min.
PWM Frequency	For Linear Operation	200Hz max.
	Frequency Limit	1000Hz max.
ANALOGUE DIMMING CONTROL (Leave open if not used - do not tie to +Vin)		
Input Voltage Range	0V min. / 10V max.	
Control Voltage Range	0V min. / 5.1V max.	
Note: The analogue dimming range is from 0% to 100%, but the output can be unstable below 10%, when using the analogue dimming function.		
Vref Version	Vref Voltage	4.95V
	Vref Output Current	0.5mA
	Vref Output Short Circuit Current	0.1µA typ.
Ambient Temperature (free air convection)	350mA	-40°C to +80°C
	500mA	-40°C to +80°C
	700mA	-40°C to +75°C
	1000mA	-40°C to +60°C
	1200mA	-40°C to +50°C

Analogue and PWM Dimming Control Note: Leave open if not used - do not tie to +Vin

continued on next page

LIGHTLINE
DC/DC-Converter
with 5 year Warranty

RECOM

Constant Current Buck LED Driver



EN-50121-3-2 Certified
EN-60950-1 Certified
UL-60950-1 Certified

RCD-48

Derating Graph

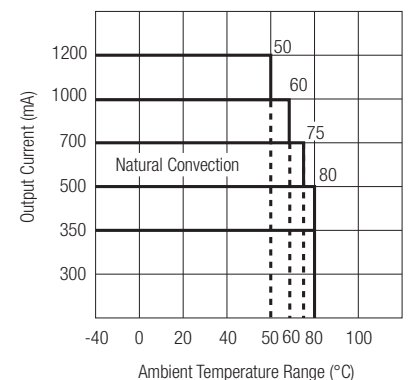

Refer to Application Notes

Specifications (typical at 25°C, nominal input voltage, rated output current unless otherwise specified)

Storage Temperature	-55°C to +125°C	
Case Thermal Impedance	10°C/W typ.	
Soldering Temperature	265°C / 10sec. max.	
Relative Humidity	95% RH	
Input Filter	Capacitor only	
Short Circuit Protection	Continuous, Auto Recovery	
Case Material	Non Conductive Black Plastic	
	Metal Case	
Potting Material	Silicone Potting Material (UL94V-0)	
Case Dimensions	Plastic Case	32.6 x 16.65 x 11.10 mm
	Metal Case	32.6 x 16.0 x 11.2 mm
Package Weight	Pinned (Plastic Case)	13g
	Wired (Plastic Case)	16g
	Pinned (Metal Case)	16g
Packing Quantity	Pinned (Plastic/Metal Case)	29 pcs.
	Wired (Plastic Case)	12 pcs.
MTBF (using MIL-HDBK217F)	+25°C	1700 x 10 ³ hours
(Nominal Vin at Full Load)	<i>Note: Detailed Information see Application Notes chapter "MTBF"</i>	
Safety	Shock / Vibration	EN61373
	EMC RAILWAYS	EN50121-3-2:2006
	Conducted	EN55011
	Radiated	EN55011
	ESD	EN61000-4-2
	Radiated Immunity	EN61000-4-3
	Fast Transient	EN61000-4-4
	Surge	EN61000-4-5
	Conducted Immunity	EN61000-4-6

Safe Operating Area

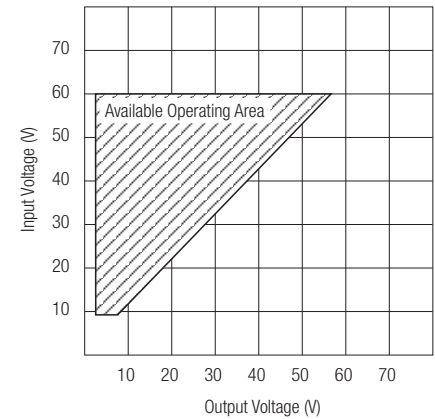

Note:

1 All LED Drivers may not be used without a load. They must be switched on the primary side only. Noncompliance may damage the LED or reduce its lifetime.

Package Style and Pinning

Through Hole Case (Plastic)

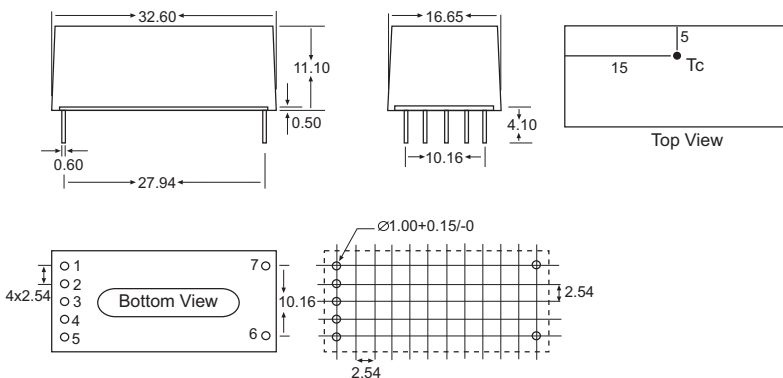

Through Hole Case (Metal)

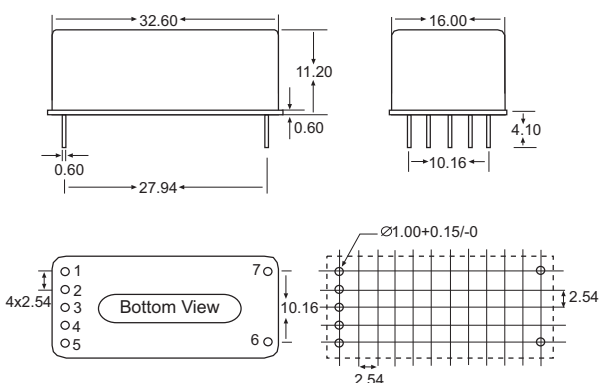

Pin Connections	RCD-48-x.xx	
Pin#	Function	Comments
1	+Vin	DC Supply
2	GND	Do not connect to -Vout
3	Vref	Vref Voltage 5V typ.
4	PWM/ON/OFF	Leave open if not used
5	Analogue Dimming	Leave open if not used
6	-Vout	LED Cathode Connection
7	+Vout	LED Anode Connection

Unit: mm
Tolerance:
XX.X ± 0.5 mm
XX.XX ± 0.25 mm

Package Style and Pinning

Wired Version (Plastic)

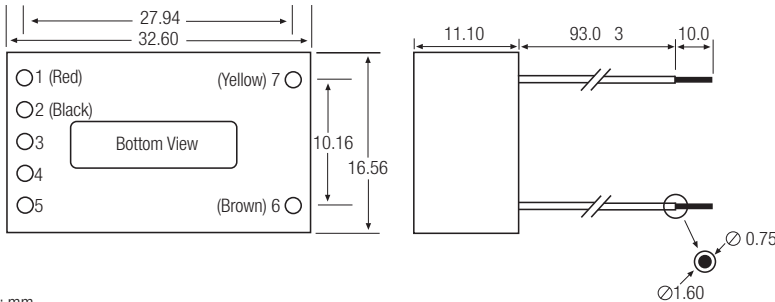

Unit: mm
Tolerance:
XX.X ± 1.0 mm
XX.XX ± 0.25 mm

Wire Connections Pin#	Function	RCD-48-x.xx/W Wire color
1	+Vin	Red
2	GND	Black
3	Vref	Yellow
4	PWM/ON/OFF	Blue
5	Analogue Dimming	Green
6	LED-	Brown
7	LED+	Yellow

Wires: UL/CSA approved (22AWG/300V)

EMI Filter Suggestions

Class B

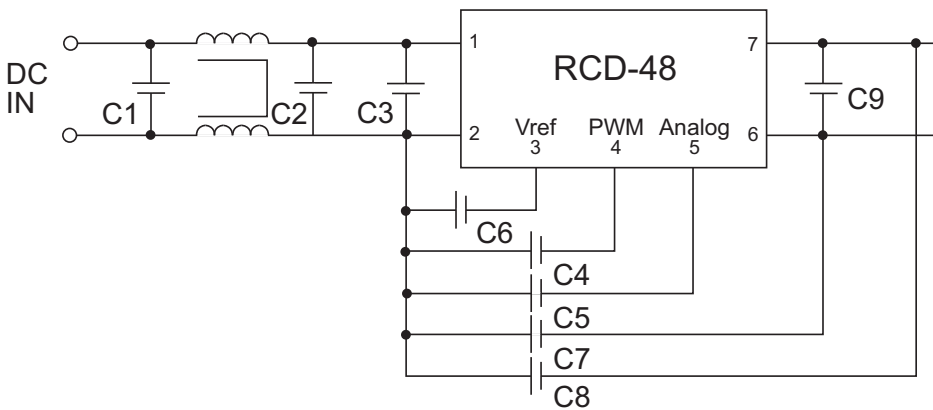

LOAD

L1	1mH (e.g. WE744272102)
C1	10µF
C2	1µF
C3	100nF close to Pins
C4 - C9	10nF

RCD-48

Filter Suggestion

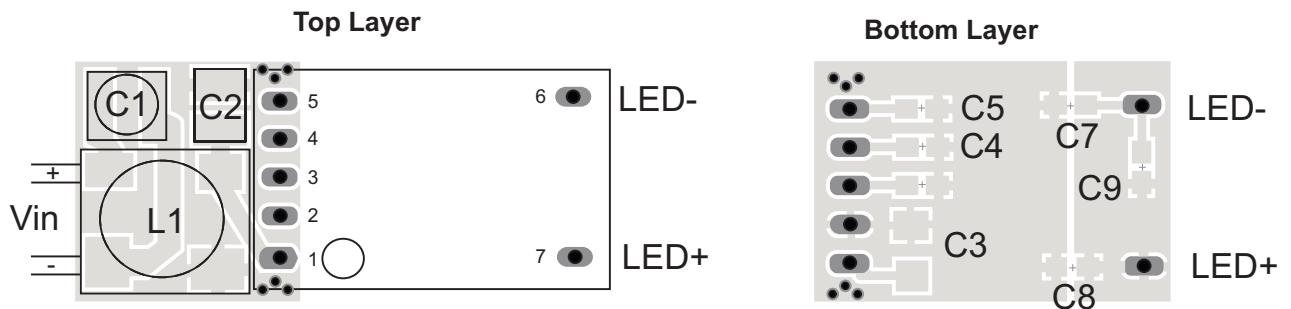

Standard Application

Single String Application

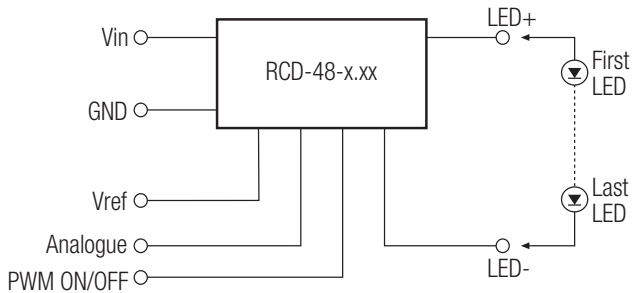

PWM Dimming Controlled

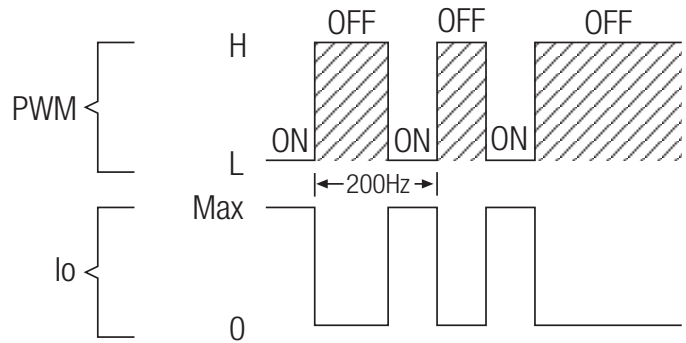

Dimming Controlled by Analog Voltage

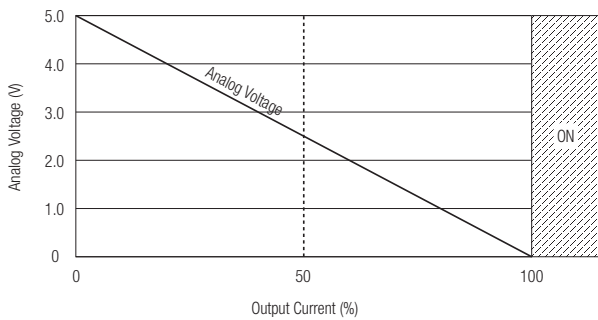

Lighting/Backlighting Wall Application

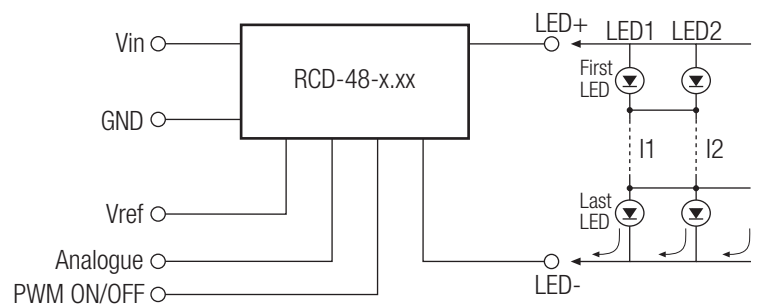

High Efficiency Lighting

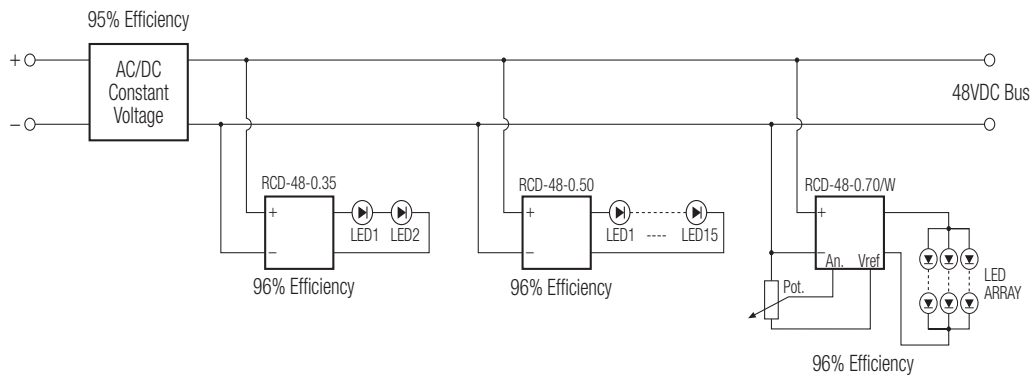

Note:
It is not possible to parallel the drivers to increase the current.

The product information and specifications are subject to change without prior notice. All products are designed for non-safety critical commercial and industrial applications. The Buyer agrees to implement safeguards that anticipate the consequences of any failures that might cause harm, loss of life and/or damage property.

Features

LED DRIVER

- Buck- Boost LED Driver up to $V_{out}=40V$
- Constant Current Output (350 or 500mA)
- Digital PWM and Analogue Voltage Dimming
- High Efficiency to 92%
- EN60950-1 and UL60950-1 Certified
- EMC Class A Without Extern Components
- Pinned or Wired Version
- 5 Year Warranty

Description

The RBD-12 series is a Buck-Boost constant current source designed for driving high power LED applications. Two output currents are available, 350mA and 500mA, and the maximum output voltage is 40V. The drivers have digital and analogue voltage dimming control and a regulated reference 5V output. Typical applications are solar, off-grid lighting, mobile traffic signs and battery-powered lighting. The wired version is IP67 rated.

Selection Guide

Part Number	Input Range (VDC)	Output Current (mA)	Output Voltage (VDC)	Dimming Control	Efficiency typ. (%)
RBD-12-0.35*	8-36	0-350	2-40	Digital + Analogue	92
RBD-12-0.50*	8-36	0-500	2-40	Digital + Analogue	92

*add suffix "/W" for wired version with Vref output and analogue + PWM dimming control (seven wires)

Specifications (typical at 25°C, nominal input voltage, rated output current unless otherwise specified)

Operating Input Voltage Range		8-36VDC
Absolute Maximum Input Voltage		38VDC
Output LED String Voltage Range (depending on the input voltage, see Safe Operating Area)		2V min. / 40V max.
Input Filter		Capacitor
Max. Capacitance Load		100µF max.
Output Current Accuracy	(Note 1)	±5% typ.
Internal Power Dissipation	350mA (Vin=36V, Vout=40V)	1.63W typ.
	500mA (Vin=36V, Vout=40V)	2.33W typ.
Output Current Stability (Note 2)	Vin=24V, Vout=2-40V	±2% max.
Output Current Ripple and Noise (20MHz BW)	350mA (Vin=24V, Vout=40V)	35mAp-p typ.
	500mA (Vin=24V, Vout=40V)	45mAp-p typ.
Reflected Back Ripple Current (20MHz BW)	Vin=24V, Vout=6-40V	70mAp-p max.
Switching Frequency		350kHz typ.
Efficiency at Full Load	Vin=24V	92% typ.
Vref	Nominal 5V	0.8mA max.
PWM DIMMING CONTROL & REMOTE ON/OFF CONTROL		
Input Voltage Range		0V min. / 5V typ. / 10V max.
Threshold Voltage	Device ON	2V min.
	Device OFF	0.1V max.
Frequency		1000Hz max.
ANALOGUE DIMMING CONTROL		
Input Voltage Range		0V min. / 10V max.
Control Voltage Range		0.2±0.1V min. / 1.5±0.1V max.
Operating Temperature (see Derating Graph)	350mA	-40°C to +75°C
	500mA	-40°C to +65°C
Case Temperature		115°C max.
Storage Temperature		-55°C to +125°C
Case Thermal Impedance		10°C/W
Soldering Temperature	Pinned Version	265°C/10sec. max.
Relative Humidity		95% RH max.
Short Circuit Protection	Continuous	Auto Recovery
Overtemperature Protection	(Auto Recovery)	125°C ± 5°C (MOSFET)
Case Material		Non Conductive Black Plastic

continued on next page

LIGHTLINE
DC/DC-Converter
with 5 year Warranty

RECOM

Constant Current Buck-Boost LED Driver



EN-60950-1 certified
UL-60950-1 certified

RBD-12

Derating Graph

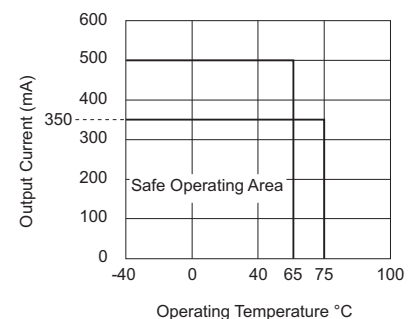

Refer to Application Notes

Specifications (typical at 25°C, nominal input voltage, rated output current unless otherwise specified)

Potting Material	Silicone Potting Material (UL94V-0)	
Case Dimensions	32.60 x 16.65 x 11.10 mm	
Package Weight	pinned version	13g
	wired version	17g
Packing Quantity	pinned version	29 pcs.
	wired version	12 pcs.
MTBF (using MIL-HDBK217F at 25°C)	1700 x 10 ³ hours	
Certification		
EN General Safety	Report: SPCLVD1111102	EN60950-1:2006 + A12:2011
IEC General Safety	Report: SPCLVD1111102	IEC60950-1:2005
UL General Safety	Report: E224736	UL60950-1, 2nd Edition

All LED Drivers may not be used without a load. They must be switched on the primary side only. Noncompliance may damage the LED or reduce its lifetime.

Note 1: Output Current Accuracy is defined as:
 $[(I_{out} - I_{out} \text{ "rated"}) / I_{out} \text{ "rated"}] \times 100$

Note 2: Output Current Stability is defined as:
 $[(I_{out} \text{ "deviation"} - I_{out} \text{ "nominal"}) / I_{out} \text{ "nominal"}] \times 100$
 $I_{out} \text{ (deviation)} = \text{maximum Deviation (min. Load, max. Load)}$

Package Style and Pinning

RBD-12-x.xx - Through Hole Case

Pin Connections

Pin#	Function	Comments
1	+Vin	DC Supply
2	Vref	Vref Voltage 5V typ.
3	Analogue Dimming	Leave open if not used
4	PWM/ON/OFF	Leave open if not used
5	GND	Do not connect to -Vout
6	-Vout	LED Cathode Connection
7	+Vout	LED Anode Connection

Unit: mm
Tolerance:
XX.X ± 0.5 mm
XX.XX ± 0.25 mm

RBD-12-x.xx/W - Wired Version

Wire Connections

Pin#	Function	RBD-12-x.xx/W Wire color
1	+Vin	Red
2	Vref (5V typ.)	Yellow
3	Analogue Dimming	Green
4	PWM/ON/OFF	Blue
5	GND	Black
6	LED-	Brown
7	LED+	Yellow

Unit: mm
Tolerance:
X ± 1 mm
XX.X ± 0.5 mm
XX.XX ± 0.25 mm
Wires: UL/CSA approved (22AWG/300V)

Standard Applications

- EN55022 Class A without external filter
- EN55015 without filter
- EN55022 Class B with filter:

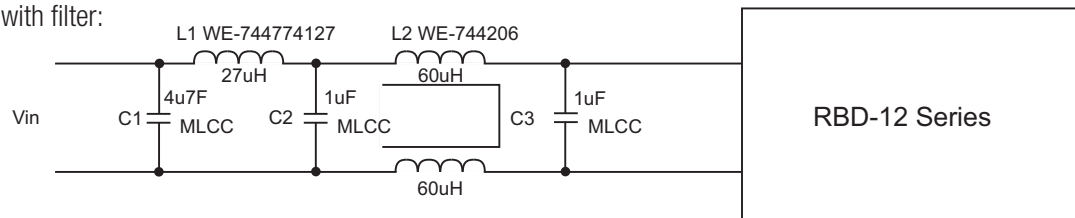

Standard Application

Single String Application

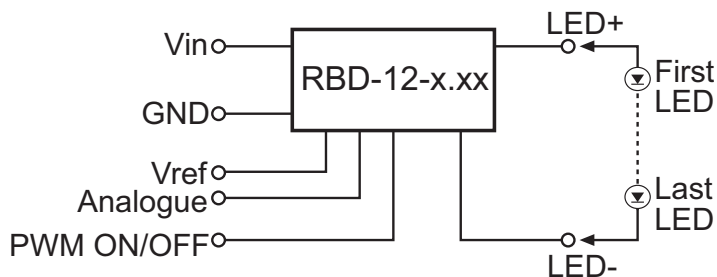

PWM Dimming Controlled

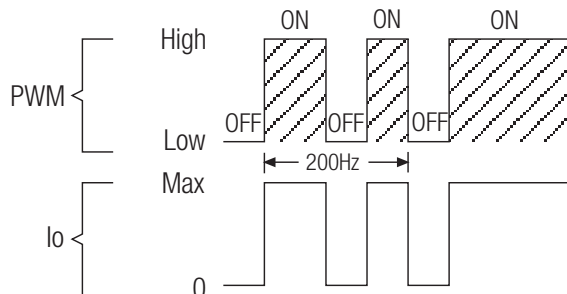

Solar Lighting Application

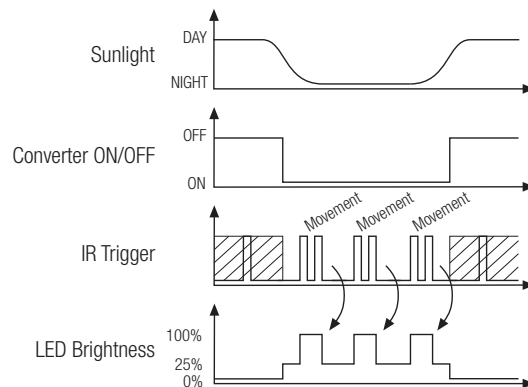
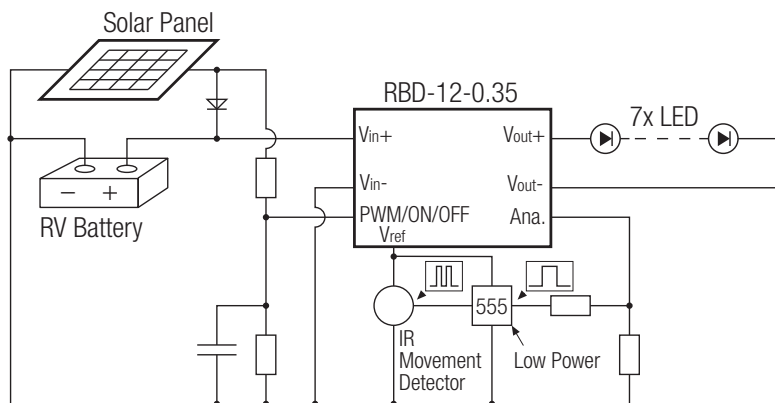

Safe Operating Area

500mA

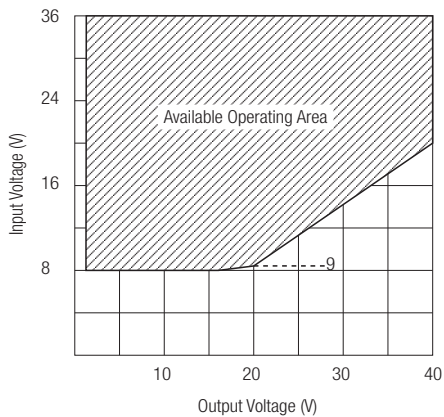

Vin 8V up to Vout = 17V
 Vin 9V up to Vout = 20V
 Vin 12V up to Vout = 24V
 Vin 16V up to Vout = 32V

350mA

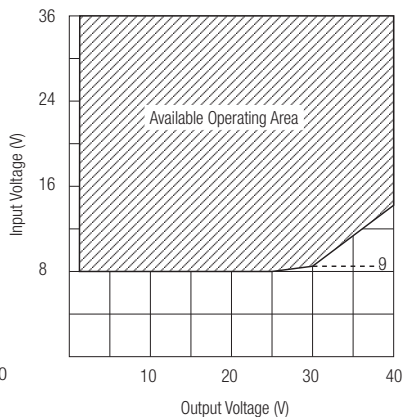

Vin 8V up to Vout = 25V
 Vin 9V up to Vout = 27V
 Vin 12V up to Vout = 36V

Dimming Controlled by Analog Voltage

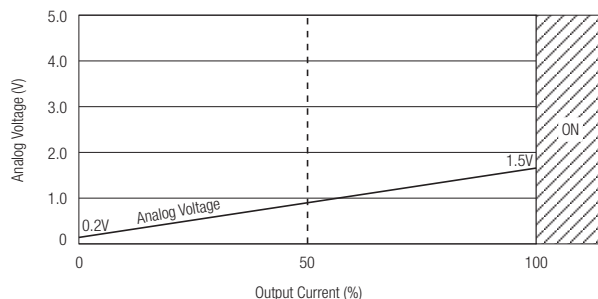

Note:

It is not possible to parallel the drivers to increase the current.

Features

LED Driver

- 3W Class II AC-DC LED Power Supply
- 350mA to 700mA CC/CV Output
- ENEC, UL, RCM and CB Certified
- Universal Input Voltage Range
- Fused Input and Protected Output
- 3kVAC Isolation
- IP66
- Low Cost
- 3 Year Warranty

Description

A compact universal AC input 3W constant current switching power module suitable for driving 1 - 6 high power LEDs. The output (dual constant voltage / constant current mode) current limit is fixed at 350mA, 500mA or 700mA. At lower output currents, the output is constant voltage. Connections are via 118mm long flying leads.

Selection Guide

Part Number	CV Mode		CC Mode		Efficiency typ. (%)
	(VDC)	(mA)	(VDC)	(mA)	
RACD03-350	15	0-350	2.5-15	350	72
RACD03-500	11	0-500	2.5-11	500	71
RACD03-700	6	0-700	2.5-6	700	62

Specifications (typical at 25°C and after warm up time unless otherwise specified)

Input Voltage Range	90-264VAC or 120-370VDC	
Rated Power	3W nom. / 5W max.	
Input Frequency Range	47-63 Hz	
Output Voltage Range	2.5 - 15VDC max.	
Inrush Current (<2mS)	230VAC	10A max.
Leakage Current	240VAC/50Hz	0.2mA typ.
Input Fuse	Built-in	T1A
Input Current	350mA Verison	20mA
	500mA Version	25mA
	700mA Version	38mA
Output Current Accuracy (combined Tolerance, Load Regulation and Line Regulation)	±10%	
Minimum Load	Open Circuit Protected	1 LED
Output Ripple	0.1Ap-p max.	
Hold Up Time	18ms min.	
Operating Frequency	66kHz typ.	
AC RMS Isolation Voltage (input to output)	3.75kV / 1 minute typ., 3kV / 1 minute min.	
Temperature Coefficient	±0.02%/°C typ.	
Overload Protection	120% typ.	
Short Circuit Protection	Continuous Current Limit	
Output Overvoltage Protection	Zener Diode Clamp	
Overtemperature Protection	Shutdown, Automatic restart after cooling down	
Operating Temperature Range (free air convection, according to CE/UL)	Ambient Temperature	-20°C to +50°C
	Case Temperature	65°C max.
Operating Temperature Range (free air convection, according to ENEC)	Ambient Temperature	-20°C to +40°C
	Case Temperature	75°C max.
Storage Temperature Range	-25°C to +85°C	
Humidity	95% RH max.	
IP Rating	IP66	
PCB Material	Plastic Resin with Fibreglass (UL94V-0)	
Case Material	Plastic	
Weight	45g	

continued on next page

LIGHTLINE

AC/DC-Converter

with 3 year Warranty

RECOM

3 Watt Single Output

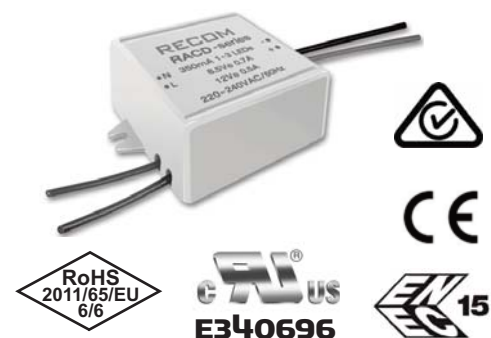

UL-8750 Certified
EN-61347 Certified
ENEC Certified

RACD03

Refer to Application Notes

Specifications (typical at 25°C and after warm up time unless otherwise specified)

Packing Quantity			10pc
Designed to meet Standards	Electrical Lighting, EMC Emissions Limits for Harmonics Emissions EMC Compatibility: Flicker and Voltage Variations Electrical Lighting: EMC Immunity Class II Power Supply Safety FCC	EN55015:2006 + A1: 2007 + A2:2009 EN 61000-3-2:2006 EN 61000-3-3:2006 EN 61547:1995 + A1:2000 UL1310 FCC18A	
Certifications	LED Lighting Safety (E340696) RCM (U21376) ENEC General Safety ENEC Safety of AC supplied Control Gear for LED Modules	UL8750 AS/NZS 61347.1:2002, IEC 61347-2-13 EN 61347-1: 2008 EN 61347-2-13: 2006	
Design Lifetime	25°C ambient		>20 x 10 ³ hours in operation
Connections	AC Input Live AC Input Neutral LED + LED -	Brown Wire, AWG18, 172mm + 5-7mm stripped and tinned Blue Wire, AWG18, 172mm + 5-7mm stripped and tinned Red Wire, AWG18, 128mm + 5-7mm stripped and tinned Black Wire, AWG18, 128mm + 5-7mm stripped and tinned	

Note:

All LED Drivers may not be used without a load. They must be switched on the primary side only. Noncompliance may damage the LED or reduce its lifetime.

Characteristics

Constant Current (CC) and Constant Voltage (CV) Graph

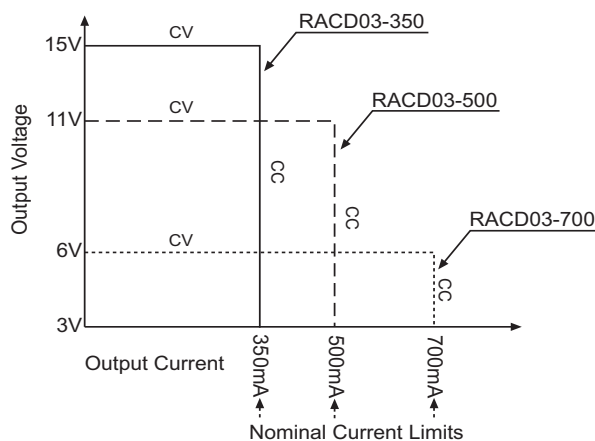

Package Style and Pinning

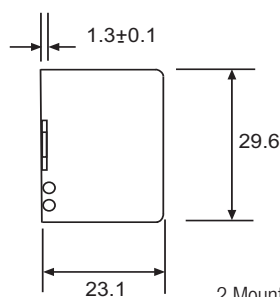
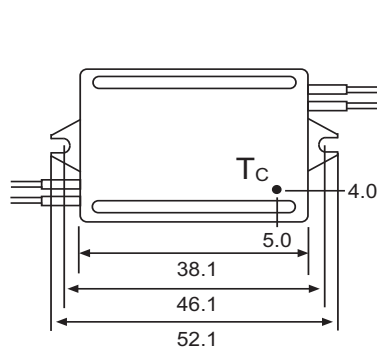

2 Mounting screws are included
T_c = Case Temperature Measuring Point

Wire Connections

Wire	Function
Brown	VAC in (L)
Blue	VAC in (N)
Red	LED+
Black	LED-

Tolerance
XX = +1mm/ -0.5mm
XX.X = +/- 0.25mm

Features

LED Driver

- 6W AC-DC Class II LED Power Supply
- 350mA to 700mA CC/CV Output
- ENEC, UL, RCM and CB Certified
- Universal Input Voltage Range
- Fused Input, Protected Output
- 3kVAC Isolation
- Low Cost
- 3 Year Warranty

Description

A compact universal input 6W constant current switching power module suitable for driving up to 12 high power LEDs. The output (dual constant voltage / constant current mode) current limit is fixed at 350mA, 500mA or 700mA. At lower output currents, the output is constant voltage.

Selection Guide

Part Number	Nominal Input Voltage (VAC)	Input Current at full load (mA)	Output Voltage Range (VDC)	Output Current (mA)	Max # LEDs	Efficiency typ. (%)
RACD06-350	universal	120	2.5-24	350	6 x 1W	79
RACD06-500	universal	120	2.5-15	500	12 x 0.5W	70
RACD06-700	universal	120	2.5-12	700	3 x 2W	72

Specifications (typical at 25°C and after warm up time unless otherwise specified)

Input Voltage Range	90-264VAC or 120-370VDC	
Rated Power	6W nom. / 7.5W max.	
Input Frequency Range	47-63 Hz	
Power Factor	Full Load, 115VAC/230VAC	0.4
Output Voltage Range	350mA CC	2.5 - 22VDC
	0-300mA CV	24V typ.
	500mA CC	2.5 - 13VDC
	0-490mA CV	15V typ.
	700mA CC	2.5 - 10VDC
	0-600mA CV	12V typ.
Inrush Current (<2mS)	115VAC/230VAC	10A max.
Leakage Current	115VAC/240VAC - 60/50Hz	0.4mA typ.
Input Fuse (Built-in)	Standard	T2A
Input Current	Full Load, Nominal Vin	see table
Output Current Accuracy (combined Tolerance, Load Regulation and Line Regulation)	±10%	
Minimum Load	Open Circuit Protected	1 LED
Output Ripple	0.2Ap-p max.	
Hold Up Time	18ms min.	
Operating Frequency	132kHz max.	
AC RMS Isolation Voltage (input to output)	3.75kV / 1 minute typ., 3kV / 1 minute min.	
Temperature Coefficient	±0.02%/°C typ.	
Overload Protection	120% typ.	
Short Circuit Protection	Continuous Current Limit	
Output Overvoltage Protection	350mA Version	24V Zener Diode Clamp
	500mA Version	14V Zener Diode Clamp
	700mA Version	12V Zener Diode Clamp
Overtemperature Protection	Shutdown, Automatic restart after cooling down	
Operating Temperature Range (free air convection, according to CE/UL)	Ambient Temperature	-20°C to +40°C
	Case Temperature	70°C max.
Operating Temperature Range (free air convection, according to ENEC)	Ambient Temperature	-20°C to +50°C
	Case Temperature	70°C max.

continued on next page

LIGHTLINE

AC/DC-Converter

with 3 year Warranty

RECOM

6 Watt Single Output



UL-8750 Certified
EN 61347 Certified
ENEC Certified

RACD06

Specifications (typical at 25°C and after warm up time unless otherwise specified)

Storage Temperature Range	-40°C to +85°C	
Humidity	95% RH max.	
IP Rating	IP20, Indoor Use Only	
Weight	34g	
Packing Quantity	10pc	
PCB Material	(UL94V-0)	Plastic Resin with Fibreglass
Case Material	(UL94V-0)	Plastic
Designed to meet Standards	Electrical Lighting, EMC Emissions Limits for Harmonics Emissions EMC Compatibility: Flicker and Voltage Variations Electrical Lighting: EMC Immunity Class II Power Supply Safety FCC	EN55015:2006 + A1: 2007 + A2:2009 EN 61000-3-2:2006 EN 61000-3-3:2006 EN 61547:1995 + A1:2000 UL1310 FCC18A
Certifications	LED Lighting Safety (E340696) RCM (U21382) ENEC General Safety ENEC Safety of AC supplied Control Gear for LED Modules	UL8750 AS/NZS 61347.1:2002, IEC 61347-2-13 EN 61347-1: 2008 EN 61347-2-13: 2006
Design Lifetime	25°C ambient	>20 x 10 ³ hours in operation
Connections	AC Input LED Output	Screw terminal Screw Terminal

Note:
All LED Drivers may not be used without a load. They must be switched on the primary side only. Noncompliance may damage the LED or reduce its lifetime.

Characteristics

Constant Current (CC) and Constant Voltage (CV) Graph

RACD06-350

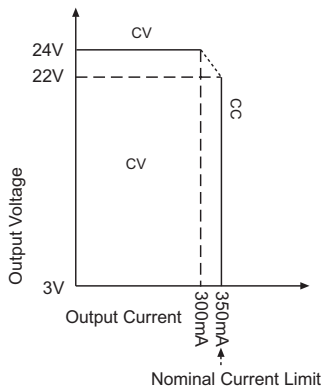

RACD06-500

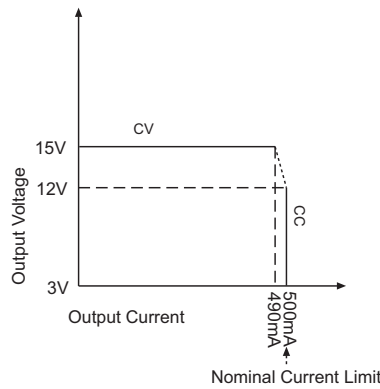

RACD06-700

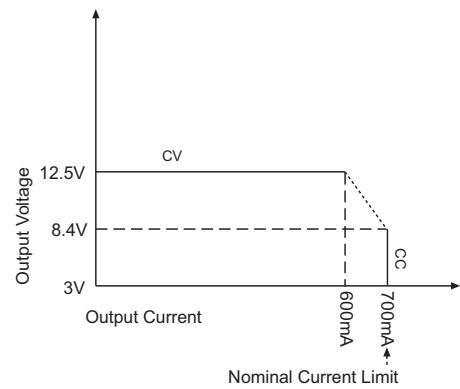

RACD06

Package Style and Pinning

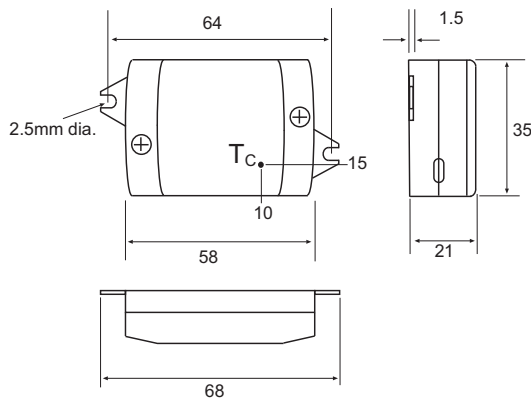

2 Mounting screws are included

Tc = Case Temperature Measuring Point

Connections

CN1	Function
L	VAC in (L)
N	VAC in (N)
CN2	Function
+	LED+
-	LED-

Tolerance
XX = +/-0.5mm
XX.X = +/-0.25mm

The product information and specifications are subject to change without prior notice. All products are designed for non-safety critical commercial and industrial applications. The Buyer agrees to implement safeguards that anticipate the consequences of any failures that might cause harm, loss of life and/or damage property.

Features

LED DRIVER

- Universal AC Input 90-295VAC
- 250mA, 350mA, 500mA, 700mA Output
- Constant Current Operation
- Isolation 3.75kVAC
- Overcurrent and Short Circuit Protection
- IP67 Rated

Selection Guide

Part Number	Rated Power (W)	Output Current (mA)	Output Voltage (VDC)	Constant Current Range (VDC)	Efficiency (min.)
RACD07-250	7	250	28	14 - 28	75%
RACD07-350	7	350	21	10 - 20	70%
RACD07-500	7	500	14.5	5 - 14.5	70%
RACD07-700	7	700	11	3 - 10.5	70%

Specifications (measured at 115VAC / 230VAC and 25°C ambient temperature)

Input Voltage Range	90-295 VAC	
Rated Power	7W nom.	
Input Frequency Range	47-63Hz	
Current Accuracy	±3% typ. / ±7% max.	
Output Current Ripple	30mA _{p-p} typ.	
Voltage Accuracy (includes load, line and tolerance)	±5%	
AC Input Current	0.2A	
Start-up Time	<1S	
Hold-Up Time	18ms min.	
Operating Frequency	45kHz	
Isolation Voltage	3.75kVAC / 1 minute	
Short Circuit Protection	Continuous	
Over Current Protection	Constant Current Mode Protection	
Overload Protection	105% - 120% typ.	
Output Overvoltage Protection	Zener Diode Clamp	
Storage Humidity	10% - 90% RH	
Operating Humidity	20% - 90% RH Non-Condensing	
Weight	74g	
Dimension	57 x 41 x 24mm	
Packing Quantity	100pcs / Carton	
Operating Temperature Range (free air convection)	Ambient Temperature	-20°C to +40°C
	Case Temperature	65°C max.
Storage Temperature Range	-40°C to +80°C	
IP Rating	IP67	
Isolation Resistance	100MΩ / 500VDC at 25°C	
PCB Material	(UL94V-0)	Plastic Resin with Fibreglass
Case Material	(UL94V-0)	Plastic
Safety Standards		
UL General Safety (E340696)	UL8750 (based on 1310)	
General Safety (Report 1201032E-01)	EN61347-1	
LVD Safety (Report PSE101-0791)	EN61347-2-13	
EMC Harmonics (Report 1201032E-01)	EN61000-3-2	
EMC Flicker (Report 1201032E-01)	EN61000-3-3	
EMC Emissions (Report 1201032E-01)	EN55015	

continued on next page

LIGHTLINE
AC/DC-Converter
with 3 year Warranty

RECOM

7 Watt
Single
Output



UL 8750 Certified
EN 61347 Certified
EN 61347-2-13 Certified

RACD07

Specifications (measured at 115VAC / 230VAC and 25°C ambient temperature)

Design Lifetime		70 x 10 ³ hours max.
MTBF (+25°C)	using MIL-HDBK 217F	200 x 10 ³ hours min.

Notes:

1. All LED Drivers may not be used without a load. They must be switched on the primary side only. Noncompliance may damage the LED or reduce its lifetime.
2. The use of a circuit breaker with C-characteristic is recommended.

Typical Characteristics

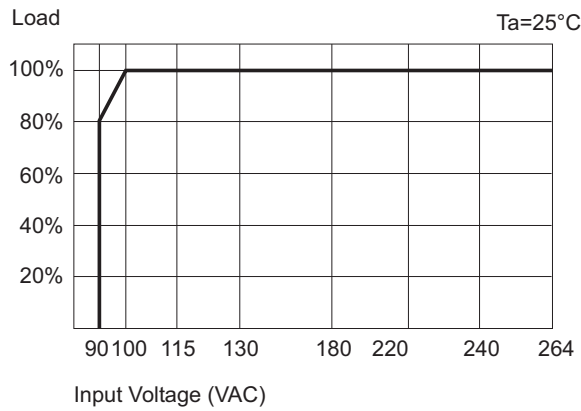

RACD07

Package Style & Pinning

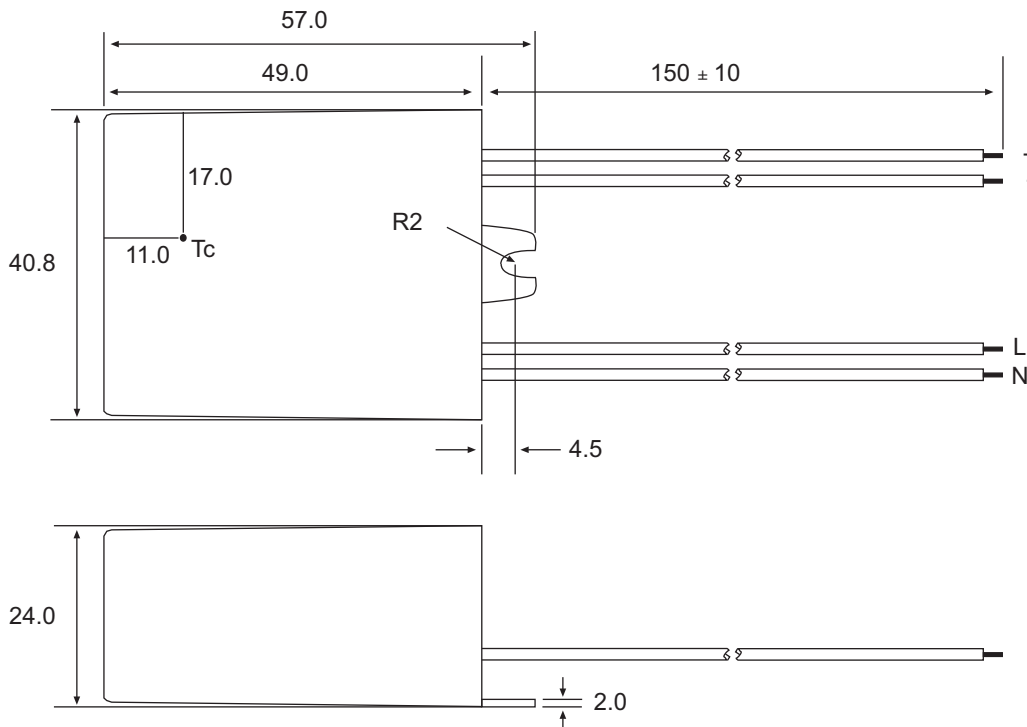

Wire Connections	
Wire	Function
Red	LED+
Black	LED-
Brown	VAC in (L)
Blue	VAC in (N)
Tolerance	
XX.X = +/- 0.2mm	

The product information and specifications are subject to change without prior notice. All products are designed for non-safety critical commercial and industrial applications. The Buyer agrees to implement safeguards that anticipate the consequences of any failures that might cause harm, loss of life and/or damage property.

Features

LED DRIVER

- 12W Class II AC/DC LED Power Supply
- 350mA, 500mA or 700mA Constant Current Output
- ENEC, UL, RCM and CB Certified
- Universal AC Input
- Active Power Factor Corrected >0.95
- Fused Input, Protected Output
- 3kVAC Input/Output Isolation
- Output Socket Connector
- cUL/UL-8750 Certified
- Low Cost
- Long 5 Year Warranty

Description

A compact 12W constant current switching power module suitable for driving up to ten high power LEDs ($V_f = 3.6V$). The output current is fixed at 350mA, 500mA or 700mA. Active power factor correction is standard and the converters are UL8750 certified for use with LED assemblies. The driver module features both screw terminal and socket output connections. The socket connector avoids the possibility of miswiring and damaging the LED load if the LEDs are pre-assembled into a wiring harness or lamp fitting.

Selection Guide

Part Number	Nominal Input Voltage (VAC)	Input Current at 230VAC (mA)	Output Voltage Range (VDC)	Output Current (mA)	Max # LEDs
RACD12-350	universal	200	3-36	350	10 x 1W
RACD12-500	universal	200	3-24	500	6 x 2W
RACD12-700	universal	200	3-17	700	4 x 2W, 8 x 1W

Specifications (typical at 25°C and after warm up time unless otherwise specified)

Input Voltage Range	90VAC-264VAC
Rated Power	12 Watts max.
Input Frequency Range	47-63 Hz
Power Factor	Full Load, 115VAC/230VAC 0.95
THD	Full Load, 115VAC 7% max. Full Load, 230VAC 14% max.
Open Circuit Voltage (Zener Clamp)	350mA Version 39VDC 500mA Version 26VDC 700mA Version 19VDC
Inrush Current (<2mS)	115VAC/230VAC 10A max.
Input Current	230VAC, Full Load 200mA max.
Leakage Current	115VAC/240VAC - 60/50Hz 0.5mA typ.
Input Fuse	Standard T1A
Output Current Accuracy	(combined Tolerance, Load Regulation and Line Regulation) ±10%.
Minimum Load	Open Circuit Protected 1 LED
Hold Up Time	18ms min.
Operating Frequency	50-120kHz typ.
Efficiency at Full Load	78%
RMS Isolation Voltage (input to output)	3kVAC / 1 minute
Temperature Coefficient	±0.02%/°C typ.
Overload Protection	120% typ.
Short Circuit Protection	Continuous Current Limit
Output Overvoltage Protection	Zener Diode Clamp

continued on next page

LIGHTLINE
AC/DC-Converter
with 5 year Warranty

RECOM

**12 Watt PFC
Single
Output**



**UL-8750 Certified
cUL-8750 Certified
ENEC 61347 Certified**

RACD12

Refer to Application Notes

LIGHTLINE

AC/DC-Converter

RACD12

Series

Specifications (typical at 25°C and after warm up time unless otherwise specified)

Overtemperature Protection	Shutdown, Automatic restart after cooling down	
Operating Temperature Range (free air convection, according to CE/UL)	Ambient Temperature	-20°C to +50°C
	Case Temperature	81°C max.
Operating Temperature Range (free air convection, according to ENEC)	Ambient Temperature	-20°C to +50°C
	Case Temperature	85°C max.
Weight	100g	
Packing Quantity	1pc	
Storage Temperature Range	-40°C to +100°C	
Humidity	95% RH max.	
IP Rating	IP20, Indoor Use Only	
PCB Material	Plastic Resin with Fibreglass (UL94V-0)	
Case Material	Plastic	
Designed to meet Standards	Electrical Lighting, EMC Emissions	EN55015:2006 + A1: 2007 + A2:2009
	Limits for Harmonics Emissions	EN 61000-3-2:2006
	EMC Compatibilty: Flicker and Voltage Variations	EN 61000-3-3:2006
	Electrical Lighting: EMC Immunity	EN 61547:1995 + A1:2000
	Class II Power Supply Safety	complies with UL1310
	FCC	complies with FCC18A
THD	<20%	
Certifications	LED Lighting Safety	UL8750
	LED Lighting Safety (Canada)	cUL8750
	RCM (U21381)	AS/NZS 61347.1:2002, IEC 61347-2-13
	ENEC Certification, General Safety	EN 61347-1: 2008
	ENEC Certification, Safety of AC supplied Control Gear for LED Modules	EN 61347-2-13: 2006
Design Lifetime	25°C ambient	>70 x 10 ³ hours in operation
Connections	AC Input	Screw terminal
	LED Output	Screw Terminal
	LED Output	5.5mm Socket with 2mm Pin (Suitable matching plug Switchcraft S760 or similar)*

Note:
All LED Drivers may not be used without a load. They must be switched on the primary side only. Noncompliance may damage the LED or reduce its lifetime.

Package Style and Pinning

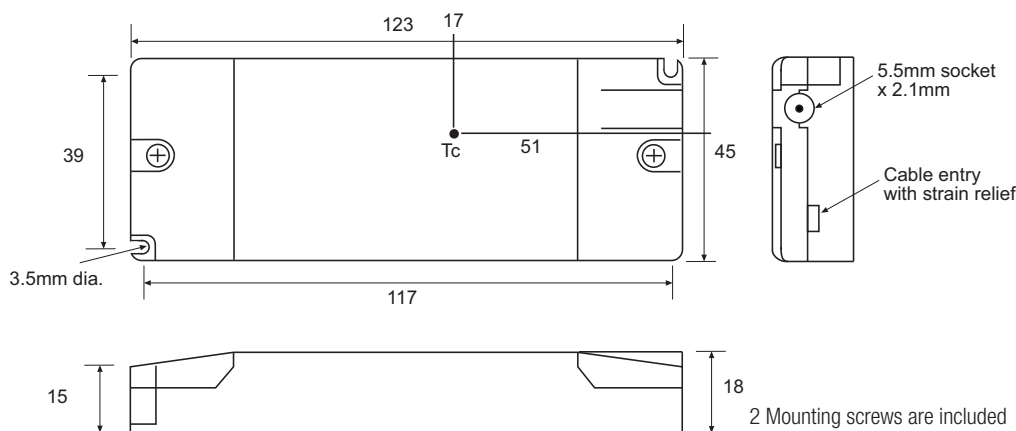

Connections	
CN1	Function
L	VAC in (L)
N	VAC in (N)
CN2	Function
+	LED+
-	LED-
5.5mm Socket* Function	
Pin	LED+
Shell	LED-
Tolerance	
XX	= +/-0.5mm
XX.X	= +/-0.25mm

2 Mounting screws are included

Tc= Case Temperature Measuring Point

Features

LED DRIVER

- 20W Class II AC-DC LED Power Supply
- 350mA , 500mA, 700mA or 1050mA Outputs
- ENEC, UL, RCM and CB Certified
- Universal AC Input
- Active Power Factor Correction >0.95
- Fused Input, Protected Output
- 3kVAC Isolation
- cUL/UL8750 Certified, CE Marked
- Output Connector to avoid miswiring
- Low Cost
- Long 5 Year Warranty

Description

A compact 20W constant current switching power module suitable for driving high power LEDs ($V_f = 3.6V$). The output current is fixed at 350mA, 500mA, 700mA or 1050mA. Active power factor correction is standard. This series features both screw terminal and socket output connections. The socket connector avoids the possibility of miswiring and damaging the LED load if the LEDs are preassembled into a wiring harness or lamp fitting.

Selection Guide

Part Number	Input Voltage Range (VAC)	Input Current at full load (mA)	Nom. Output Voltage Range (VDC)	Output Current (mA)	Max # LEDs
RACD20-350	universal	260	6-56	350	15 x 1W
RACD20-500	universal	260	6-40	500	11 x 2W
RACD20-700	universal	260	6-29	700	8 x 2W, 8+8 x 1W
RACD20-1050	universal	260	5-17	1050	6 x 3W, 5+5 x 2W

Specifications (typical at 25°C and after warm up time unless otherwise specified)

Input Voltage Range	Standard	90-264VAC
Rated Power		20 Watts max.
Input Frequency Range		47-63 Hz
Power Factor	Full Load, 115VAC/230VAC	0.95
THD	Full Load, 115VAC/230VAC	12% max.
Open Circuit Voltage	350mA Version	57VDC
(Zener Clamp)	500mA Version	43VDC
	700mA Version	32VDC
	1050mA Version	19VDC
	Inrush Current (<2mS)	115VAC/230VAC
Input Current	230VAC, Full Load	260mA typ.
Leakage Current	115VAC/240VAC - 60/50Hz	0.5mA typ.
Input Fuse	Standard	T1A
Output Current Accuracy	(combined Tolerance, load Regulation and Line Regulation)	±10%
Minimum Load	Open Circuit Protected	2 LEDs
Hold Up Time		18ms min.
Operating Frequency		40 - 100 kHz typ.
Efficiency at Full Load		83%
RMS Isolation Voltage (input to output)		3kVAC / 1 minute
Temperature Coefficient		±0.02%/°C typ.
Overload Protection		120% typ.
Short Circuit Protection		Continuous Current Limit
Output Overvoltage Protection		Zener Diode Clamp

continued on next page

LIGHTLINE

AC/DC-Converter

with 5 year Warranty

RECOM

20 Watt PFC Single Output



UL 8750 Certified
cUL 8750 Certified*
ENEC 61347 Certified

RACD20

* RACD20-700 and -1050 only has cUL

Refer to Application Notes

Specifications (typical at 25°C and after warm up time unless otherwise specified)

Overtemperature Protection	Shutdown, Automatic restart after cooling down	
Operating Temperature Range (free air convection, according to CE/UL)	Ambient Temperature	-20°C to +50°C
	Case Temperature	78.6°C max.
Operating Temperature Range (free air convection, according to ENEC)	Ambient Temperature	-20°C to +50°C
	Case Temperature	85°C max.
Weight	160g	
Packing Quantity	1pc	
Storage Temperature Range	-40°C to +100°C	
Humidity	95% RH max.	
IP Rating	IP20, Indoor Use Only	
PCB Material	Plastic Resin with Fibreglass (UL94V-0)	
Case Material	Plastic	
Designed to meet Standards	Electrical Lighting, EMC Emissions	EN55015:2006 + A1: 2007 + A2:2009
	Limits for Harmonics Emissions	EN 61000-3-2:2006
	EMC Compatibility: Flicker and Voltage Variations	EN 61000-3-3:2006
	Electrical Lighting: EMC Immunity	EN 61547:1995 + A1:2000
	Class II Power Supply Safety	complies with UL1310
	FCC	complies with FCC18A
THD	<20%	
Certifications	LED Lighting Safety (E340696)	UL8750
	LED Lighting Safety (Canada)	cUL8750 (RACD20-700 only)
	RCM (U21380)	AS/NZS 61347.1:2002, IEC 61347-2-13
	ENEC CE Certification, General Safety	EN 61347-1: 2008
	ENEC CE Certification, Safety of AC supplied Control Gear for LED Modules	EN 61347-2-13: 2006
Design Lifetime	25°C ambient	>70 x 10 ³ hours in operation
Connections	AC Input	Screw terminal
	LED Output	Screw Terminal
	LED Output	5.5mm Socket with 2mm Pin (Suitable matching plug Switchcraft S760 or similar)

Note:

All LED Drivers may not be used without a load. They must be switched on the primary side only. Noncompliance may damage the LED or reduce its lifetime.

Package Style and Pinning

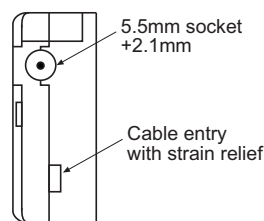
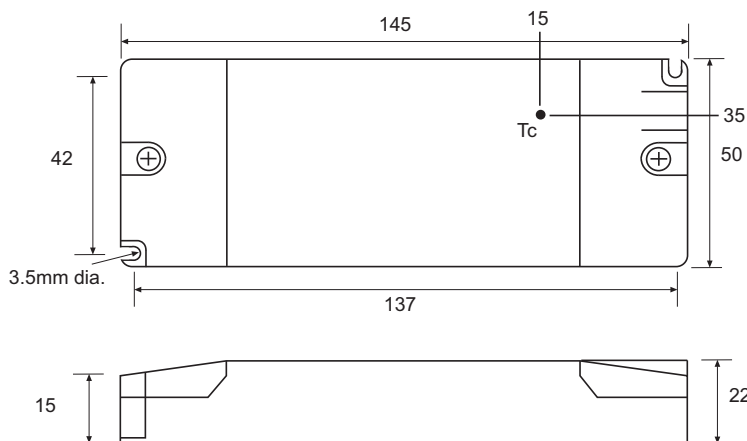

Connections

CN1	Function
L	VAC in (L)
N	VAC in (N)
CN2	Function
+	LED+
-	LED-
5.5mm Socket*	Function
Pin	LED+
Shell	LED-

Tolerance
XX = +/-1mm
XX.X = +/-0.5mm

2 Mounting screws are included

Tc=Case Temperature Measuring Point

The product information and specifications are subject to change without prior notice. All products are designed for non-safety critical commercial and industrial applications. The Buyer agrees to implement safeguards that anticipate the consequences of any failures that might cause harm, loss of life and/or damage property.

Features

LED DRIVER

- 20W Class II AC-DC LED Power Supply
- 350mA, 500mA, 700mA, 1050mA Output
- Universal AC Input (90-305VAC)
- Active Power Factor Correction
- Isolation Voltage 3.75kVAC
- Efficiency to 80%
- ENEC, UL, RCM and CB Certified
- Low Cost

Selection Guide

Part Number	Input Range (VAC)	Output Current (mA)	Output Voltage (VDC)	Efficiency (typ.)
RACD20-350/277	90 - 305	350	28 - 57	80%
RACD20-500/277	90 - 305	500	20 - 40	80%
RACD20-700/277	90 - 305	700	14 - 29	80%
RACD20-1050/277	90 - 305	1050	10.8 - 19	80%

Specifications

Input Voltage Range	90-305VAC or 130-430VDC	
Output Power Range	other types	10 Watts min., 20 Watts max.
	1050mA Version	12 Watts min., 20 Watts max.
Input Frequency Range	50/60 Hz typ.	
Power Factor	Full Load, 115VAC	>0.90
	Full Load, 230VAC	>0.90
	Full Load, 277VAC	>0.85
THD	Full Load, 115VAC/230VAC/277VAC	14% max.
Open Circuit Voltage	350mA Version	59 VDC
	500mA Version	44 VDC
	700mA Version	33 VDC
	1050mA Version	23 VDC
Input / Output Isolation	3750 VAC / 1 minute	
Operating Frequency	50/60 Hz	
Overload Protection	105% ~ 110%	
Weight	195g	
Dimension Drawing	80 x 74 x 26.5mm	
THD	<20%	
Temperature Coefficient	according to standards	
Operating Temperature Range	Ambient Temperature	-20°C to +50°C
(free air convection, according to CE/UL)	Case Temperature	85°C max.
Operating Temperature Range	Ambient Temperature	-20°C to +50°C
(free air convection, according to ENEC)	Case Temperature	85°C max.
Storage Temperature	-40°C to +80°C	
Max. Case Temperature (Tc)	90°C	
Acoustic Noise	30dB (10cm)	
IP Rating	IP66	
Certifications	ENEC CE Certification, General Safety	EN61347-2-13
	LED Lighting Safety (E340696)	UL1310 Class B, UL8750
	RCM (21378)	AS/NZS 61347.1:2002, IEC 61347-2-13
	Harmonics	EN61000-3-2 Class C
	EMC	EN55015 Class B
		FCC Part 18 Class B
Design Lifetime	50 x 10 ³ hours	

LIGHTLINE

AC/DC-Converter
with 5 year Warranty

RECOM

20 Watt PFC Single Output



UL 8750 Certified
ENEC 61347 Certified

RACD20/277

Derating-Graph (Ambient Temperature)

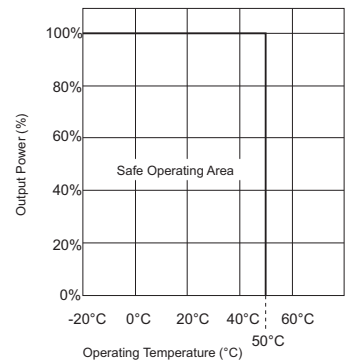

Note:

All LED Drivers may not be used without a load. They must be switched on the primary side only. Noncompliance may damage the LED or reduce its lifetime.

Refer to Application Notes

Standard Application Circuit

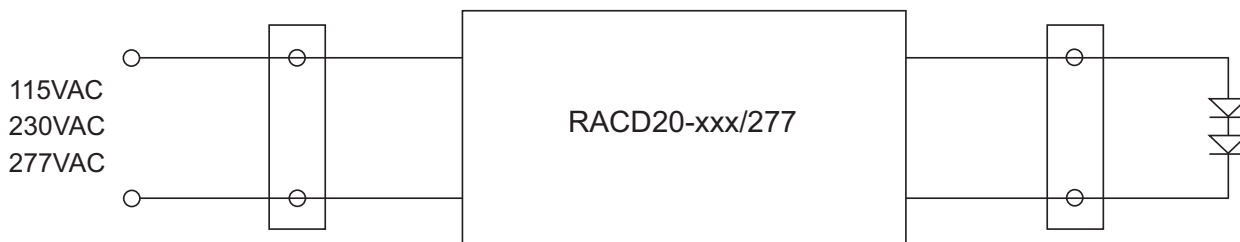

Notes:

- LED power supply is internally fused. No external fuse is required.
- Do not connect or disconnect LED load while the converter is on. This may damage the LED or reduce its life.
- Class 2 Power supply

Standard Package Style & Pinning

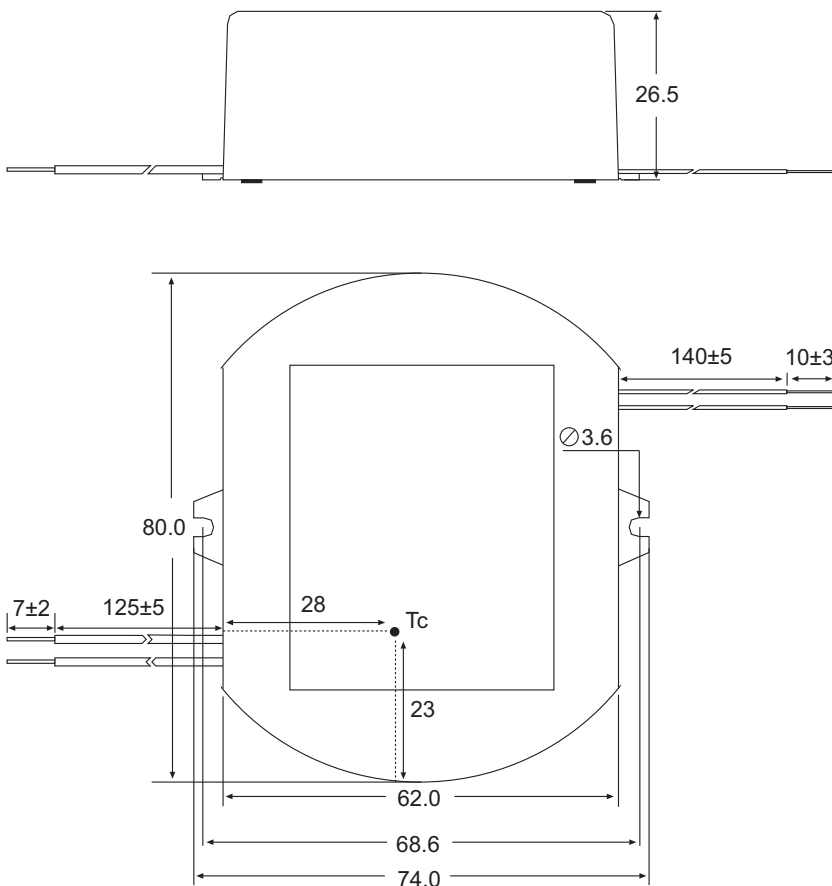

Wire Connections

Wire	Function
Brown	VAC in (L)
Blue	VAC in (N)
Red	LED+
Black	LED-

Tolerance
 XX = +1mm/ -0.5mm
 XX.X = +/- 0.25mm

Features

LED DRIVER

- 20W Class II AC-DC LED Power Supply
- 2x Independent Constant Current Outputs or Single High Current Output (Jumper selectable)
- 1-10V or Rheostat Dimmable (15%~100%)
- 3kVAC Isolation
- Active Power Factor Correction >0.95
- Fused Input, Protected Outputs
- CE Marked
- Long 5 Year Warranty

Description

A compact 20W constant current switching power module suitable for driving either two independent strings of LEDs or a single string high power LEDs (mode selection is via a jumper under the output cover plate). When used in dual output mode, the two outputs are independently regulated and can be used with asymmetric LED loads. The output current can be dimmed using either an external 150kOhm rheostat or via a 1-10V external voltage. Active power factor correction is standard. Connections are via screw terminals and the AC input feature loop-through connections to allow daisy-chaining of the converters.

Selection Guide

Part Number	Input Voltage Range (Nominal VAC)	Input Current at full load (mA)	Output Voltage Range (VDC)	Output Current (mA)	Max # LEDs
RACD20-350D (700mA single output mode)	230VAC	260	2x (3-34) 3-34	2x (50~350) 100~700	2x (10 x 1W) 10 x 2W
RACD20-350D-US (700mA single output mode)	110VAC	510	2x (3-34) 3-34	2x (50~350) 100~700	2x (10 x 1W) 10 x 2W

Specifications (typical at 25°C and after warm up time unless otherwise specified)

Input Voltage Range	230VAC 110VAC	200-264VAC 90-130VAC
Rated Power		20 Watts max.
Input Frequency Range		47-63 Hz
Power Factor	Full Load, 115VAC/230VAC	0.95
Output Voltage Range	350mA Dual Output Mode 700mA Single Output Mode	3-34VDC + 3-34VDC 3-34VDC
Inrush Current (<2mS)	115VAC/230VAC	10A max.
Input Current	230VAC, Full Load	260mA typ.
Leakage Current	115VAC/240VAC - 60/50Hz	0.5mA typ.
Input Fuse	115VAC/230VAC	T2A/T1A
Output Current Accuracy	(combined Tolerance, load Regulation and Line Regulation)	±10%
Minimum Load	Open Circuit Protected	1 LED
Output Ripple		150mA max.
Hold Up Time		18ms min.
Operating Frequency		40 - 100 kHz typ.
Efficiency at Full Load	230VAC	>80%
RMS Isolation Voltage (input to output)		3kVAC / 1 minute
Temperature Coefficient		±0.02%/°C typ.
Overload Protection		120% typ.
Short Circuit Protection		Continuous Current Limit

continued on next page

LIGHTLINE

AC/DC-Converter

with 5 year Warranty

RECOM

20 Watt PFC Single/Dual Dimmable



EN 61347 Compliant

RACD20-D

Refer to Application Notes

Specifications (typical at 25°C and after warm up time unless otherwise specified)

Dimming Control	Rheostat (15%~100%)	0-150kOhm	External Voltage (15%-100%)	1-10VDC
Overtemperature Protection				Shutdown, Automatic restart after cooling down
Operating Temperature Range (free air convection)				Ambient Temperature -20°C to +40°C Case Temp. 85°C max.
Weight				140g
Packing Quantity				1pc
Storage Temperature Range				-40°C to +100°C
Humidity				95% RH max.
IP Rating				IP20, Indoor Use Only
PCB Material				Plastic Resin with Fibreglass (UL94V-0)
Case Material				Plastic
Designed to meet Standards	Electrical Lighting, EMC Emissions			EN55015:2006 + A1: 2007 + A2:2009
	Limits for Harmonics Emissions			EN 61000-3-2:2006
	EMC Compatibilty: Flicker and Voltage Variations			EN 61000-3-3:2006
	Electrical Lighting: EMC Immunity			EN 61547:1995 + A1:2000
	Class II Power Supply Safety			UL1310
	FCC			FCC18A
THD				<20%
Certifications	LED Lighting Safety			designed to meet UL8750
	Certification, General Safety			designed to meet EN 61347-1: 2008
Design Lifetime	25°C ambient			>70 x 10 ³ hours in operation
Connections	AC Input			Screw terminal
	AC Output (loop through)			Screw terminal
	LED Outputs			Screw Terminal

Note:

All LED Drivers may not be used without a load. They must be switched on the primary side only. Noncompliance may damage the LED or reduce its lifetime.

RACD20-D

Package Style and Pinning

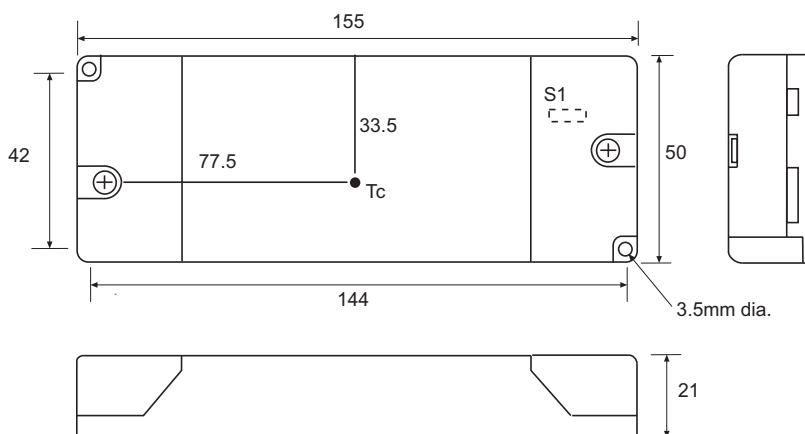

2 Mounting screws are included

Tc=Case Temperature Measurement Point

Connections

CN1	Function
L (loophthrough)	VAC out (L)
N (loophthrough)	VAC out (N)
CN2	Function
L	VAC in (L)
N	VAC in (N)
S1	Function
1+2	Dual Mode
2+3	Single Mode
CN3	Function
-	common
+	1-10V or 150k
CN4	Function
Ch1 -	LED+
Ch1 +	LED-
CN5	Function
Ch2 +	LED+
Ch2 -	LED-
Tolerance	
XX =	+/-1mm
XX.X =	+/-0.5mm

S1			
350	Ch1	350	
	Ch2	350	700

Features

LED DRIVER

- 20W Dimmable AC-DC LED Power Supply
- 350mA, 500mA, 700mA or 1050mA Outputs
- ENEC, UL, RCM and CB Certified
- Deep Dimming to 0% *
- Active Power Factor Correction >0.95
- 3.75kVAC Isolation
- Output Connector to avoid miswiring
- 5 Year Warranty

Description

The RACT20 series is a constant current dimmable AC/DC source for driving high power LED applications. The phase angle dimming function works with leading or trailing edge dimmers. This driver is suitable for indoor LED lighting systems and powers 5-15 high power LEDs or single LED arrays from 350mA up to 1A.

Selection Guide

Part Number	Input Voltage (VAC)	Output Current (mA)	Output Voltage (VDC)	Dimming Control	Efficiency typ. (%)	Max. # LEDs
RACT20-350	230	350	30-56	Triac	82	15 x 1W
RACT20-500	230	500	21-39	Triac	82	12 x 1W
RACT20-700	230	700	15-28	Triac	81	8 x 2W, 8+8 x 1W
RACT20-1050	230	1050	12-18	Triac	81	5 x 3W, 5+5 x 2W
RACT20-350-US	115	350	30-56	Triac	82	15 x 1W
RACT20-500-US	115	500	21-39	Triac	82	12 x 1W
RACT20-700-US	115	700	15-28	Triac	81	8 x 2W, 8+8 x 1W
RACT20-1050-US	115	1050	12-18	Triac	81	5 x 3W, 5+5 x 2W

Specifications (typical at 25°C, nominal input voltage, rated output current unless otherwise specified)

Input Voltage Range	RACT20-xxxx RACT20-xxxx-US	180-264VAC 90-135VAC
Rated Power		20W max.
Output Current Accuracy		±5% max.
Input Current	115VAC 230VAC	0.4A max. 0.2A max.
Input Frequency Range		47-63Hz
Power Factor	Full Load	>0.95
THD	Full Load, 115VAC Full Load, 230VAC	8% max. 11% max.
Leakage Current		<0.75mA
Open Circuit Voltage (No Load V _{out})	350mA 500mA 700mA 1050mA	60VDC max. 44VDC max. 33VDC max. 22VDC max.
Output Ripple and Noise	350mA, 500mA 700mA, 1050 mA	4.5Vp-p max. 4.0Vp-p max.
Short Circuit Protection		Hiccup mode, Auto recovery
Overtemperature Protection		95°C ±10°C (RT1) Hiccup mode, Auto recovery
Isolation Voltage		3.75kVAC / 1 minute
Efficiency at Full Load		see selection guide
Dimming		AC phase-cut dimming, work with leading/trailing edge dimmers
Operating Temperature Range (free air convection, according to CE/UL)	Ambient Temperature Case Temperature	-30°C to +50°C 85°C max.
Operating Temperature Range (free air convection, according to ENEC)	Ambient Temperature Case Temperature	-30°C to +50°C 80°C max.
Storage Temperature		-40°C to +85°C
Relative Humidity		95% RH
EMC	design refer to EN55022	Class B
IP Rating	suited for indoor LED lighting system	IP20
Design Lifetime	25°C ambient	>70 x 10 ³ hours in operation
Package Weight		145g
Packing Quantity		1 pc.
PCB Material		Plastic Resin with Fibreglass (UL94V-0)
Case Material		Plastic

continued on next page

LIGHTLINE

AC/DC-Converter

with 5 year Warranty

RECOM

20W Triac Dimmable LED Driver



UL-8750 certified

UL-60950-1 certified

European Version only:

ENEC 61347 certified

RACT20

Derating Graph

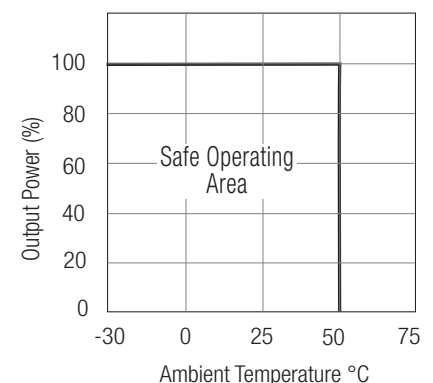

Refer to Application Notes

Specifications (typical at 25°C, nominal input voltage, rated output current unless otherwise specified)

Connections	AC Input LED Output LED Output	Screw Terminal Screw Terminal 5.5mm Socket with 2mm Pin (suitable matching plug Switchcraft S760 or similar)
Standards	ENEC Lamp Controlgear Electrical Lighting, EMC Emissions Limits for Harmonics Emissions EMC Compatibility: Flicker and Voltage Variations Electrical Lighting: EMC Immunity RCM (21377) FCC	EN61347-2-13:2006 EN61347-1:2008 EN55015:2006 + A2:2009 EN 61000-3-2:2006 + A2:2009 EN 61000-3-3:2006 EN 61547:2009 AS/NZS 61347.1:2002, IEC 61347-2-13 FCC15B
Certifications	LED Lighting Safety (E340696) Information Technology Equipment - Safety	UL8750 UL60950-1 CAN/CSA C22.2 No. 60950-1-07

*The triac dimmer must be capable of dimming down to zero

Note:

All LED Drivers may not be used without a load. They must be switched on the primary side only. Noncompliance may damage the LED or reduce its lifetime.

Characteristics

Dimming Response

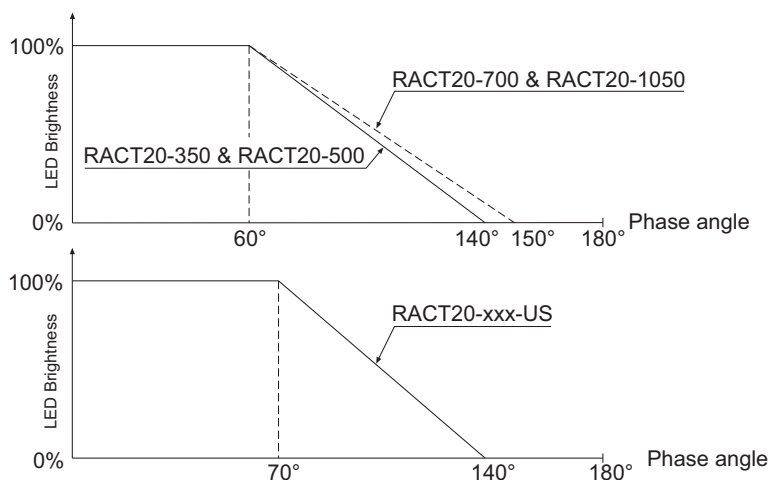

115VAC - Version

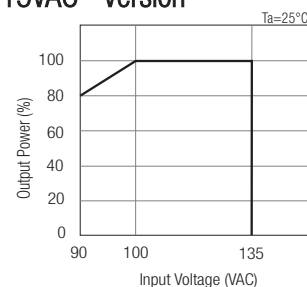

230VAC - Version

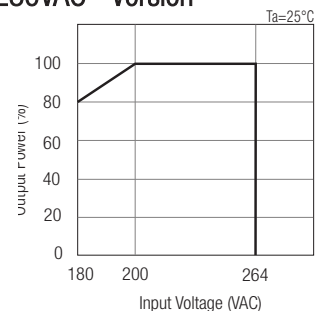

Package Style and Pinning

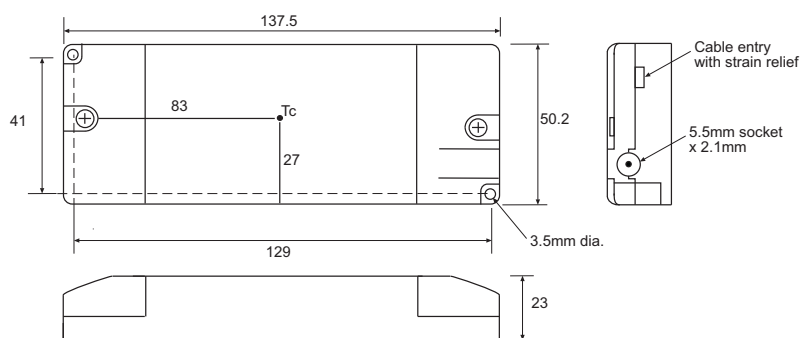

Connections

CN1	Function
L	VAC in (L)
N	VAC in (N)
CN2	
+	LED+
-	LED-
5.5mm Socket*	
Pin	LED+
Shell	LED-

Tolerance
XX = +/-1mm
XX.X = +/-0.5mm

The product information and specifications are subject to change without prior notice. All products are designed for non-safety critical commercial and industrial applications. The Buyer agrees to implement safeguards that anticipate the consequences of any failures that might cause harm, loss of life and/or damage property.

Features

LED DRIVER

- 25W Class II AC-DC LED Power Supply
- 500mA, 700mA, 1050mA or 1400mA Output
- Active Power Factor Correction >0.90
- Efficiency to 85%
- EN and UL

Selection Guide

Part Number	Rated Power (W)	Output Current (mA)	Output Voltage (VDC)	Efficiency (typ.)
RACD25-500P	25	500	42 - 52	82%
RACD25-700P	25	700	21 - 36	85%
RACD25-1050P	25	1050	16 - 24	84%
RACD25-1400P	25	1400	12-18	83%

Specifications (measured at 230VAC and 25°C ambient temperature)

Input Voltage Range	90-295 VAC or 127-417 VDC	
Input Frequency Range	47-63Hz	
Power Factor	Full Load, 230VAC	>0.90
	Full Load, 115VAC	>0.98
THD	Full Load, 115VAC/230VAC	12% max.
	Full Load, 277VAC	14% max.
Current Accuracy	700mA Version	±7%
	others	±8%
AC Input Current	115VAC	0.4A
	230VAC	0.2A
Inrush Current (<2ms)	264VAC	Cold Start 20A
Isolation Voltage	3.75kVAC / 1minute	
Short Circuit Protection	Continuous	
Over Voltage Protection	110% - 150%	
Over Temperature Protection	Rth Type	Internal Thermistor Auto-Recovery Mode
Vibration	10-500Hz, 2G, 60 Min. along X, Y and Z	
Storage Humidity	10% - 95% RH	
Operating Humidity	20% - 95% RH Non-Condensing	
Weight	220g	
Dimension	174.5 x 30.5 x 25mm	
Operating Temperature	-20°C to +50°C	
Storage Temperature	-40°C to +80°C	
Ripple & Noise	3V max.	
IP Rating	IP67	
Isolation Resistance	100MΩ / 500VDC at 25°C	
Safety Standards	EN61347-1 EN61347-2-13 UL8750 EN61000-3-2 Class C EN61000-4-2,3,4,5,6,11 EN61547 EN55015 FCC15	
MTBF (+25°C)	using MIL-HDBK 217F	200 x 10 ³ hours
Desing Lifetime	70 x 10 ³ hours	

The use of a circuit breaker with C-characteristic is recommended.

LIGHTLINE

AC/DC-Converter
with 5 year Warranty

RECOM

25 Watt PFC Single Output

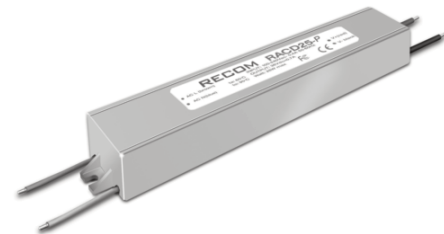

UL 8750 Certified
EN 61347 Certified

RACD25-P

Derating-Graph (Ambient Temperature)

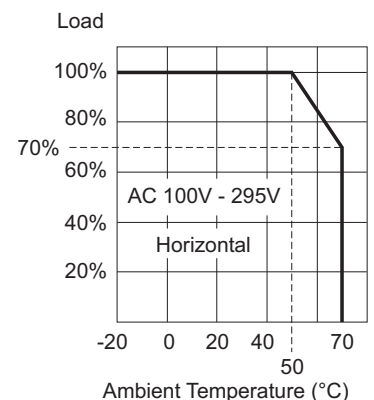

Note:

All LED Drivers may not be used without a load. They must be switched on the primary side only. Noncompliance may damage the LED or reduce its lifetime.

Refer to Application Notes

Typical Characteristics

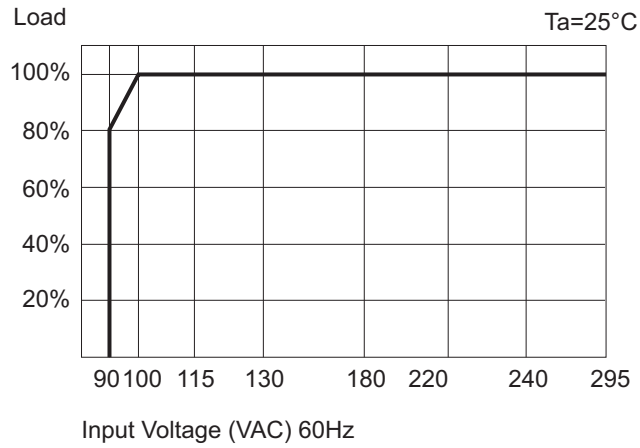

Package Style & Pinning

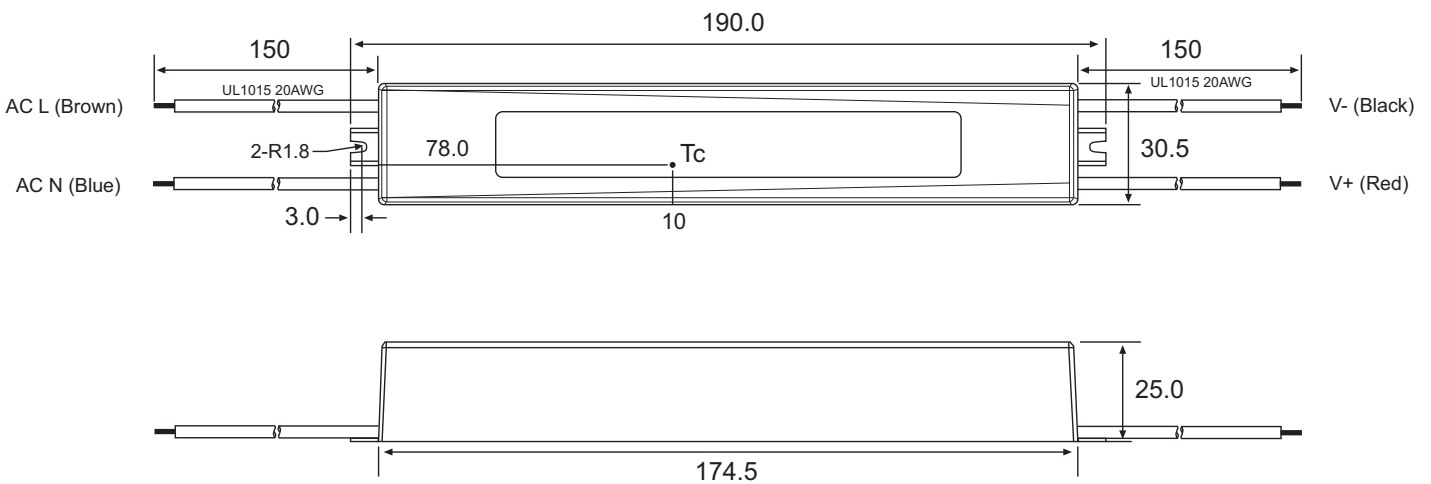

RACD25-P

The product information and specifications are subject to change without prior notice. All products are designed for non-safety critical commercial and industrial applications. The Buyer agrees to implement safeguards that anticipate the consequences of any failures that might cause harm, loss of life and/or damage property.

Features

LED DRIVER

- 25W Class II AC-DC LED Power Supply
- Constant Voltage / Constant Current Output
- Active Power Factor Correction >0.90
- Efficiency to 85%
- IP67 rated
- EN and UL

Selection Guide

Part Number	Rated Power (W)	Output Voltage (VDC)	Output Current Limit (mA)	Efficiency (typ.)
RACV25-48P	25	48	520	83%

Specifications (measured at 230VAC and 25°C ambient temperature)

Input Voltage Range	90-295 VAC or 127-417 VDC	
Input Frequency Range	47-63Hz	
Power Factor	Full Load, 230VAC	>90%
Voltage Accuracy	48V	±5%
AC Input Current	120VAC	0.4A
	230VAC	0.2A
Inrush Current (<2ms)	264VAC	Cold Start 20A
Isolation Voltage	3.75kVAC / 1 minute	
Short Circuit Protection	Continuous	
Over Voltage Protection	110% - 150%	
Over Temperature Protection	Rth Type	Internal Thermistor Auto-Recovery Mode
Vibration	10-500Hz, 2G, 60 Min. along X, Y and Z	
Storage Humidity	10% - 95% RH	
Operating Humidity	20% - 95% RH Non-Condensing	
Weight	220g	
Dimension	174.5 x 30.5 x 25mm	
Operating Temperature	-20°C to +50°C	
Storage Temperature	-40°C to +80°C	
Ripple & Noise	3V max.	
IP Rating	IP67	
Isolation Resistance	100MΩ / 500VDC at 25°C	
Safety Standards	EN61347-1 EN61347-2-13 UL8750 EN61000-3-2 Class C EN61000-4-2,3,4,5,6,11 EN61547 EN55015 FCC15	
MTBF (+25°C)	using MIL-HDBK 217F	200 x 10 ³ hours
Design Lifetime		70 x 10 ³ hours

The use of a circuit breaker with C-characteristic is recommended.

Note:

All LED Drivers may not be used without a load. They must be switched on the primary side only.

Noncompliance may damage the LED or reduce its lifetime.

LIGHTLINE
AC/DC-Converter
with 5 year Warranty

RECOM

**25 Watt PFC
Single
Output**



**UL 8750 Certified
EN 61347 Certified**

RACV25

**Derating-Graph
(Ambient Temperature)**

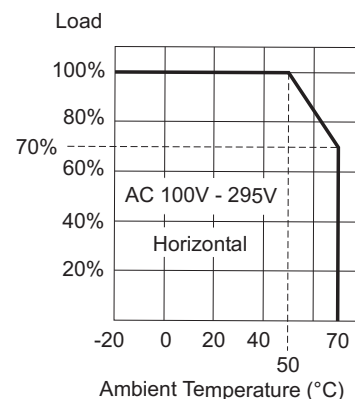

Refer to Application Notes

Typical Characteristics

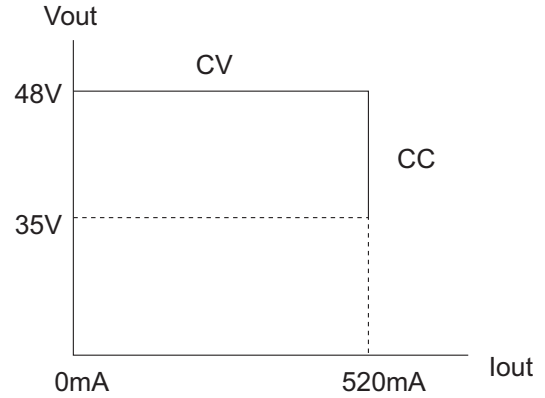
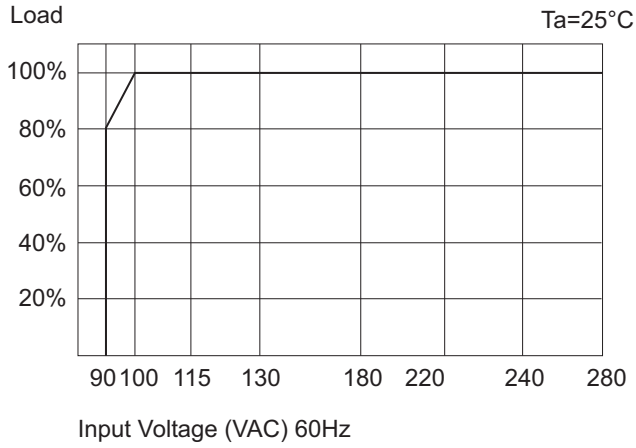

Package Style & Pinning

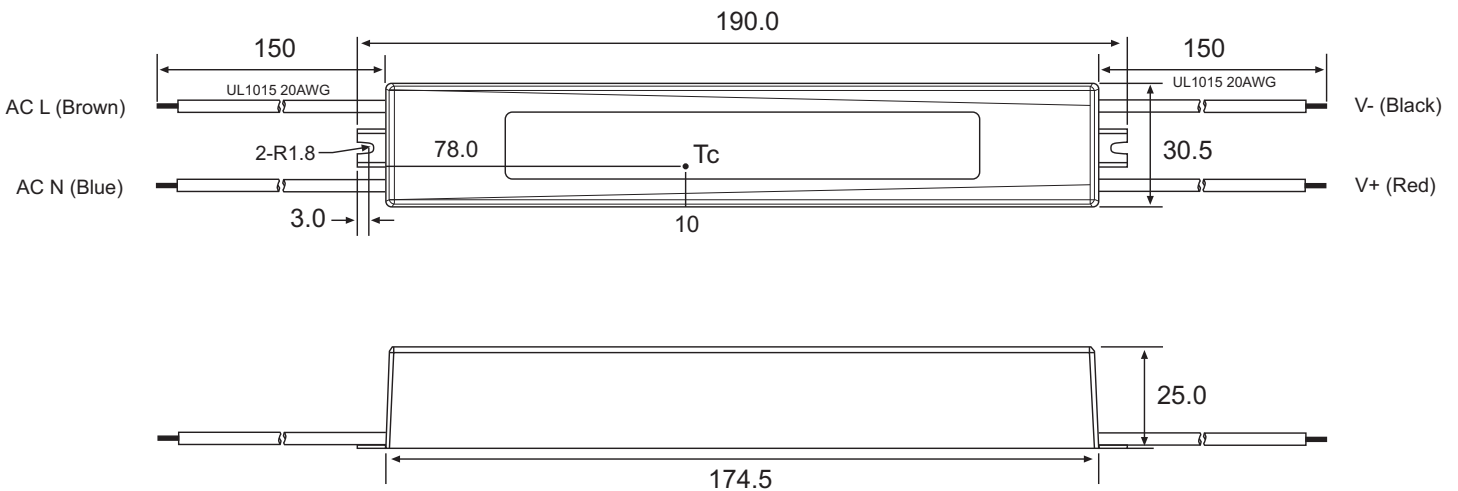

RACV25

Features

LED DRIVER

- 30W Class II AC-DC LED Power Supply
- 500mA or 700mA Constant Current
- Drives 3 - 15 High brightness LEDs
- Universal AC Input
- Active Power Factor Correction >0.95
- Fused Input, Protected Output
- 3kVAC Isolation
- UL-8750 Certified
- Output Connector to avoid miswiring
- Low Cost
- Long 5 Year Warranty

Description

A compact 30W constant current switching power module suitable for driving up to 15 high power LEDs ($V_f = 3.6V$). The output current is fixed at 500mA or 700mA. Active power factor correction is standard.

This series features both screw terminal and socket output connections. The socket connector avoids the possibility of miswiring and damaging the LED load if the LEDs are preassembled into a wiring harness or lamp fitting.

Selection Guide

Part Number	Input Voltage Range (VAC)	Input Current at full load (mA)	Output Voltage Range (VDC)	Output Current (mA)	Max # LEDs
RACD30-500	universal	390	10-56	500	15 x 2W
RACD30-700	universal	390	10-43	700	12 x 3W, 12+12 x 1W

Specifications (typical at 25°C and after warm up time unless otherwise specified)

Input Voltage Range	Standard	90-264VAC
Rated Power		30 Watts max.
Input Frequency Range		47-63 Hz
Power Factor	Full Load, 115VAC/230VAC	0.9
THD	Full Load, 115VAC	13% max.
	Full Load, 230VAC	11% max.
Open Circuit Voltage (Zener Clamp)	500mA Version	58VDC
	700mA Version	48VDC
Inrush Current (<2mS)	115VAC/230VAC	10A max.
Input Current	230VAC, Full Load	390mA typ.
Leakage Current	115VAC/240VAC - 60/50Hz	0.5mA typ.
Input Fuse	Standard	T1A
Output Current Accuracy	(combined Tolerance, load Regulation and Line Regulation)	±10%
Minimum Load	Open Circuit Protected	3 LEDs
Hold Up Time		18ms min.
Operating Frequency		40 - 100 kHz typ.
Efficiency at Full Load		85%
RMS Isolation Voltage (input to output)		3kVAC / 1 minute
Temperature Coefficient		±0.02%/°C typ.
Overload Protection		120% typ.
Short Circuit Protection		Continuous Current Limit
Output Overvoltage Protection	500mA Version	56V Zener Diode Clamp
	700mA Version	43V Zener Diode Clamp
Overtemperature Protection		Shutdown, Automatic restart after cooling down

continued on next page

LIGHTLINE

AC/DC-Converter

with 5 year Warranty

RECOM

30 Watt PFC

Single Output



UL-8750 Certified
EN 61347 Certified

RACD30

Refer to Application Notes

Specifications (typical at 25°C and after warm up time unless otherwise specified)

Operating Temperature Range (free air convection)		Ambient Temperature	-20°C to +50°C
		Case Temp.	85°C max. (500mA version: 90°C max.)
Weight			200g
Packing Quantity			1 pc
Storage Temperature Range			-40°C to +100°C
Humidity			95% RH max.
IP Rating			IP20, Indoor Use Only
PCB Material			Plastic Resin with Fibreglass (UL94V-0)
Case Material			Plastic
Designed to meet Standards	Electrical Lighting, EMC Emissions Limits for Harmonics Emissions EMC Compatibilty: Flicker and Voltage Variations Electrical Lighting: EMC Immunity Class II Power Supply Safety FCC	EN55015:2006 + A1: 2007 + A2:2009 EN 61000-3-2:2006 EN 61000-3-3:2006 EN 61547:1995 + A1:2000 UL1310 FCC18A	
THD			<20%
Certifications	LED Lighting Safety SEMKO CE Certification, General Safety SEMKO CE Certification, Safety of AC supplied Control Gear for LED Modules	UL8750 EN 61347-1: 2008 EN 61347-2-13: 2006	
Design Lifetime	25°C ambient		>70 x 10 ³ hours in operation
Connections	AC Input LED Output LED Output		Screw terminal Screw Terminal 5.5mm Socket with 2mm Pin (Suitable matching plug Switchcraft S760 or similar)

Note:

All LED Drivers may not be used without a load. They must be switched on the primary side only. Noncompliance may damage the LED or reduce its lifetime.

Package Style and Pinning

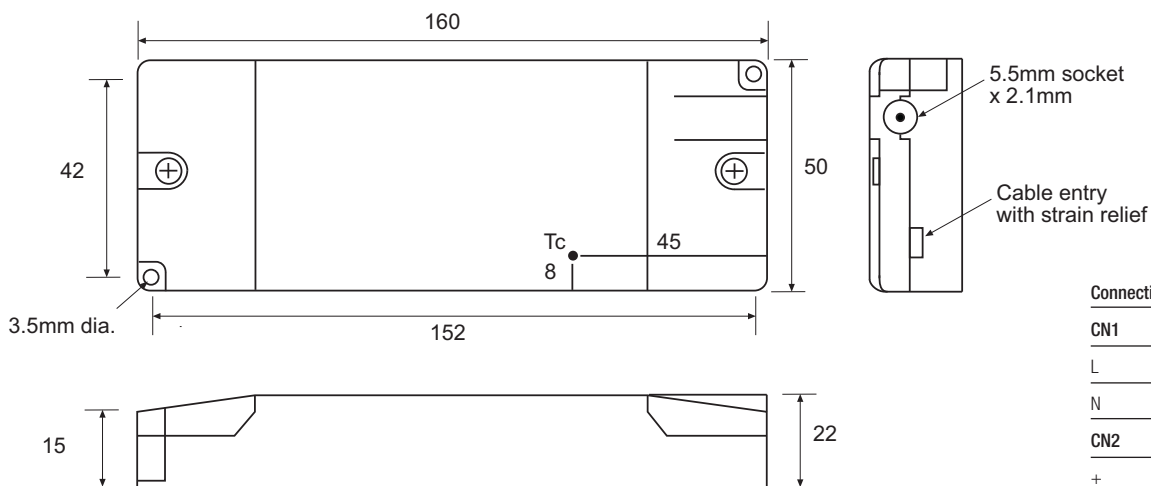

2 Mounting screws are included
Tc=Case Temperature Measuring Point

Connections	
CN1	Function
L	VAC in (L)
N	VAC in (N)
CN2	Function
+	LED+
-	LED-
5.5mm Socket	Function
Pin	LED+
Shell	LED-
Tolerance	
XX = +/-1mm	
XX.X = +/-0.5mm	

Features

LED DRIVER

- Constant Voltage Output
- ENEC, UL, RCM and CB Certified
- Power Factor Corrected
- Short Circuit, Overload and Overtemperature Protected

Selection Guide

Part Number	Input Voltage (VAC)	Output Voltage (VDC)	Output Current (mA)	Efficiency typ. (%)
RACV30-24	100-240	24	0-1250	84
RACV30-12	100-240	12	0-2500	83

Specifications (typical at 25°C, nominal input voltage and full load)

Input Voltage Range	90-264VAC or 140-370VDC	
Input Frequency Range	47-63Hz	
Input Current	Full Load	< 380mA
Power Factor Correction	Full Load	>0.92
THD	Full Load, 115VAC	12% max.
Inrush Current	(2ms peak)	30A max.
Input Fuse	internal 2A/250V	
Output Voltage Accuracy	(Output Load min <-> max)	±5%
Load Regulation	(Output Load min <-> max)	2% max.
Line Regulation	(VACin min <-> VACin max)	2% max.
Output Ripple	3% max.	
Operating Frequency	≤125kHz	
Isolation Voltage	3kVAC / 1 minute	
Operating Temperature Range (free air convection, according to CE/UL)	Ambient Temperature	-20°C to +50°C
	Case Temperature	85°C max.
Operating Temperature Range (free air convection, according to ENEC)	Ambient Temperature	-20°C to +50°C
	Case Temperature	85°C max.
Humidity	85% RH max.	
Case Material	Epoxy UL94V-0	
Weight	RACV30-24	167g
	RACV30-12	170g
MTBF	MIL STD 217F	30x10 ³ hours
Design Lifetime	70 x 10 ³ hours max.	
EMC Standards	EN55015 FCC18A	
Screw Terminal Specification	14AWG or 2.5mm ²	
Connector Plug Specification	5.5mm connector	
Short Circuit Protection	Current Limit, Automatic Restart	
Overload Protection	Full Load	110~160%
Overtemperature Protection	Tj=110°C	Automatic Restart

Package Style and Pinning

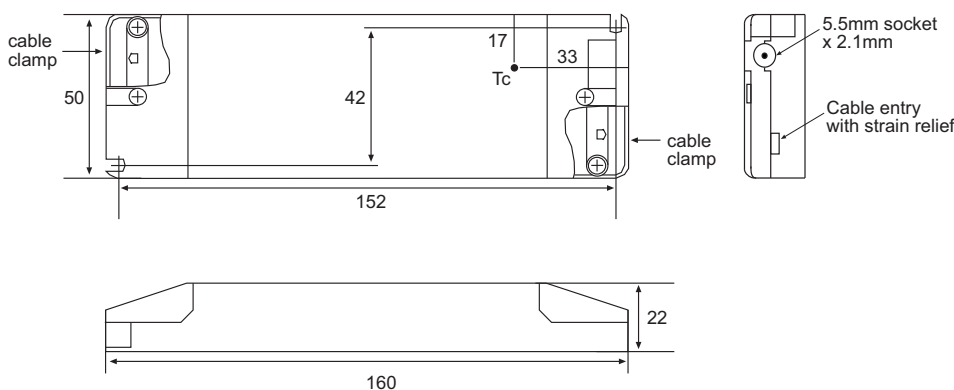

Connections	
CN1	Function
L	VAC in (L)
N	VAC in (N)
CN2	Function
+	LED+
-	LED-
5.5mm Socket*	Function
Pin	LED+
Shell	LED-

Tolerance
 XX = +/-1mm
 XX.X = */-0.5mm

LIGHTLINE
 AC/DC-Converter
 with 5 year Warranty

RECOM

30 Watt PFC
Single CV
Output



EN61347-2-13 Certified
UL-8750 Certified
cUL-8750 Certified

RACV30

Note:

All LED Drivers may not be used without a load. They must be switched on the primary side only. Noncompliance may damage the LED or reduce its lifetime.

Refer to Application Notes

The product information and specifications are subject to change without prior notice. All products are designed for non-safety critical commercial and industrial applications. The Buyer agrees to implement safeguards that anticipate the consequences of any failures that might cause harm, loss of life and/or damage property.

Features

LED DRIVER

- Universal AC Input
- Constant Current Operation
- Suitable for High Brightness LED Products
- Built-In Active PFC Function
- Overvoltage-, Short Circuit- and Over-temperature Protection
- Built-In 3 in 1 Dimming
- IP67 Rated
- Class 2 Power Unit UL1310

Selection Guide

Part Number	Output Voltage (VDC)	Rated Power (W)	Rated Current (mA)	Output Voltage Range (V)	Efficiency (typ.)
RACD45-1850A	24	45	185 - 1850	15 - 24	85%
RACD45-1250A	36	45	125 - 1250	24 - 36	86%
RACD45-1050A	48	48	105 - 1050	33 - 48	87%
RACD45-700A	57	40	70 - 700	40 - 57	87%

Specifications (measured at 230VAC and 25°C ambient temperature)

Input Voltage Range	90-305 VAC	
Input Frequency Range	47-63Hz	
Power Factor (Full Load)	120VAC	>0.98
	240VAC	>0.93
	277VAC	>0.90
THD	Full Load, 115VAC	13% max.
	Full Load, 230VAC	19% max.
DC Dimming	Open = 100%	DC 1-10V
PWM Dimming	Open = 100%	Duty 10% - 100%
	Freq.	500Hz - 3000Hz
	Voltage	Hi=10V, Low=0V
Resistance Dimming	10K - 100K Ω	
Current Accuracy	±5%	
AC Input Current	100-240VAC	0.6A
	277VAC	0.25A
Inrush Current (Cold Start)	240VAC	70A
Leakage Current	<0.5mA / 240VAC	
Start-up Time (at Full Load)	<2sec	
Isolation Voltage	3.75kVAC / 1 minute	
Short Circuit Protection	Hiccup	
Over Voltage Protection	24V	26.4 - 31.2V
	36V	39.6 - 46.8V
	48V	52.8 - 62.4 V
	57V	62.7 - 70V
Over Temperature Protection	Latch Mode	105 ± 10°C
Vibration	10-500Hz, 2G, 60Min. along X, Y and Z	
Storage Humidity	10% - 90% RH	
Operating Humidity	20% - 90% RH Non-Condensing	
Weight	420g	
Operating Temperature	-30°C to +50°C	
Storage Temperature	-40°C to +60°C	
Ripple & Noise	24V	200mV
	(at 20MHz bandwidth using 0.1uF & 47uF capacitor)	all others
IP Rating	IP67	
Isolation Resistance	100MΩ / 500VDC at 25°C	
Dimension (L*W*H)	179*45.1*32.5mm	

continued on next page

LIGHTLINE

AC/DC-Converter
with 5 year Warranty

RECOM

45 Watt PFC Single Output



EN 61347-1 Certified
EN 61347-2-13 Certified
UL8750 Certified

RACD45-A

Derating-Graph (Ambient Temperature)

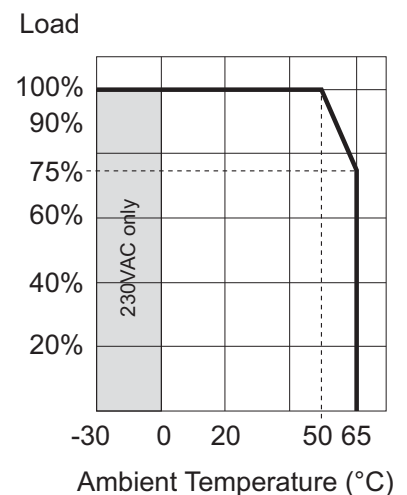

Refer to Application Notes

www.recom-electronic.com

Specifications (measured at 230VAC and 25°C ambient temperature)

Safety Standards	LED Lighting Safety	Report: E340696	UL8750
	LED Lighting Safety (Canada)	Report: E340696	cUL8750
	Class 2 Power Supply Safety	Report: E340696	UL1310
	Extra Low-Voltage Class 2 Output	Report: E340696	CSA C22.2 No. 223-M91
	LED equipment for lighting application	Report: E340696	CSA C22.2 No. 250.13-12
			EN61347-1
			EN61347-2-13
			EN61000-3-2 Class C
			EN61000-3-3
			EN61000-4-2,3,4,5,6,8,11
			EN61547
			EN55015 FCC15
Design Lifetime			70 x 10 ³ hours max.
MTBF (+25°C)	using MIL-HDBK 217F		200 x 10 ³ hours min.

3 in 1 Dimming Control (DC / PWM / Resistance)

10K-100K Resistor Dimmable (Typical):

Resistor	Single-Driver	10K	20K	30K	40K	50K	60K	70K	80K	90K	100K
	Multi-Driver	10K/N	20K/N	30K/N	40K/N	50K/N	60K/N	70K/N	80K/N	90K/N	100K/N
Output (%)		10%	20%	30%	40%	50%	60%	70%	80%	90%	100%

The length of extended wire for DIM+/- shall not exceed 20 meters. (wire ≤ 20m)

N = The number of dimmer drivers should not exceed 15. (N ≤ 15mS)

DC: 1-10V Dimmable (Typical)

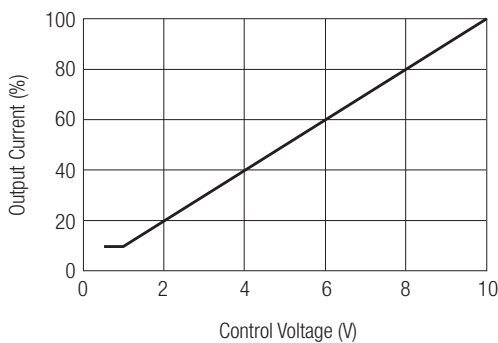

DC: 10V / PWM Dimmable (Typical)

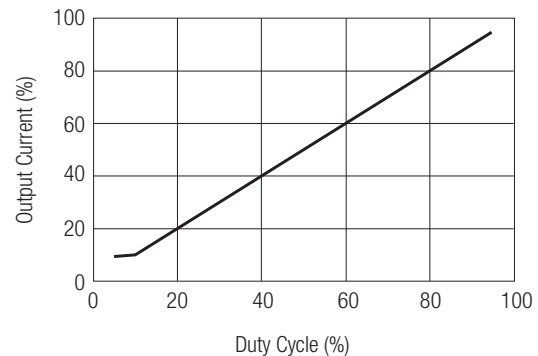

Package Style & Pinning

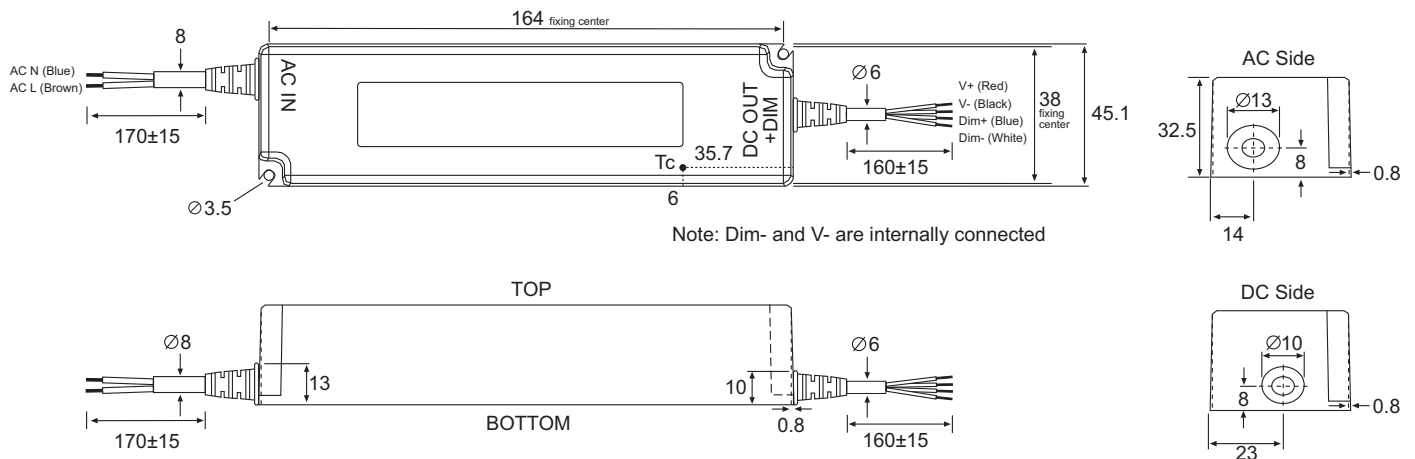

The product information and specifications are subject to change without prior notice. All products are designed for non-safety critical commercial and industrial applications. The Buyer agrees to implement safeguards that anticipate the consequences of any failures that might cause harm, loss of life and/or damage property.

Features

LED DRIVER

- 60W Class II AC-DC LED Power Supply
- Dual Mode CV or CC Output
- Power Factor Corrected
- Universal Input Voltage Range
- User Adjustable Current Limit (/OF)
- Thermal Feedback Dimming (/TOF)
- Waterproof Enclosure (/IP67)
- cUL/UL8750 Certified, CE Marked
- Class 2 Power Unit UL1310
- High Efficiency
- Long 5 Year Warranty

Description

The RACD60 is a compact universal input voltage 60W constant current power module suitable for driving high power LEDs. The LED driver has a dual mode of operation: - CV mode: at loads below the preset current limit, the RACD60 behaves as a fixed voltage source. CC mode: at loads above the preset current limit, the RACD60 behaves as a fixed current source. Thus the same power supply can be used with both CV and CC LED modules. The RACD60 series have a universal input voltage range with active power factor correction and are fully protected against output short circuit, overload and over-temperature. Three versions are available: a low cost open-frame with either internal (/OF) or external user-adjustable current limit (/TOF), and a sealed IP67 potted version (/IP67) with factory set output currents for outdoor or high humidity applications.

Selection Guide

Part Number	Output Voltage Range (min - max)	Output Current Range (min - max)	Factory Set Current Limit	Efficiency (230VAC) Typ.	Output Power Range
RACD60-4200*	11 - 13.5V	3570 - 4200mA	4.2A	85%	40-60W
RACD60-2400*	17 - 24V	2150 - 2500mA	2.4A	87%	30-60W
RACD60-2100*	21 - 28V	1400 - 2140mA	2.1A	89%	30-60W
RACD60-1400*	21 - 28V	1400 - 2140mA	1.4A	89%	30-60W
RACD60-1050*	38 - 54V	700 - 1100mA	1.0A	89%	27-60W
RACD60-700*	38 - 54V	700 - 1100mA	0.7A	89%	27-60W

* use suffix /OF for open frame version (standard) - output current limit adjustable with on-board trimmer

* use suffix /TOF for open frame version with thermal feedback - output current limit externally adjustable.

* use suffix /IP67 for waterproof potted version - fixed output currents only

ordering examples:

RACD60-700/OF= open frame, adjustable current limit preset to 700mA.

RACD60-1050/TOF=open frame, 1050mA, adjustable 700-1050mA with ext. voltage or PWM signal.

RACD60-1400/IP67 = enclosed IP67 waterproof, non-adjustable 1400mA output.

Note: all currents within range are available - use RACD60-xxx/IP67 where xxx is the desired fixed current

e.g. RACD60-900/IP67 = enclosed IP67 waterproof, non-adjustable 900mA output.

Specifications (typical at 25°C and after warm up time unless otherwise specified)

Input Voltage Range	All Versions	90-264VAC
Rated Power		60 Watts max.
Input Frequency Range	All Versions	50/60 Hz
Power Factor Correction	Full Load, 115VAC/230VAC	> 0.9
THD	Full Load, 115VAC	17% max.
	Full Load, 230VAC	20% max.
Input Current (full load)	115VAC/230VAC	0.8A / 0.4A max.
Inrush Current (cold start)	115VAC/230VAC	25A / 50A max.
Leakage Current	230VAC/63Hz	<0.7mA max.
Input Fuse	Built-in	3.15A Slow Blow
Output Current Accuracy	Full load	±5%
Output Current Adjust	Preset Potentiometer (/OF)	75% to 100% approx.
	External Voltage (/TOF)	
Line Voltage Regulation	LL to HL at Full Load	±4% typ.
Load Voltage Regulation	60% to 100% Load	±5% typ.
Minimum Load Current		see table
Operating Frequency	All Versions	65kHz typ.

continued on next Page

LIGHTLINE
AC/DC-Converter
with 5 year Warranty

RECOM

60 Watt PFC
Single Output



UL 8750 Certified
cUL 8750 Certified*
EN 61347 Certified

RACD60

* except 700mA/1100mA Versions

Input Voltage Derating (Ta=25°C)

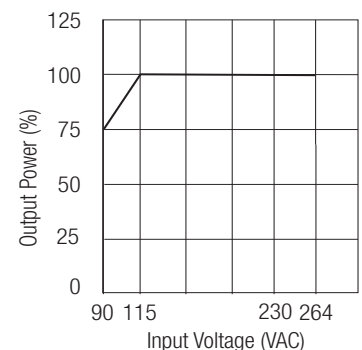

Note:

All LED Drivers may not be used without a load. They must be switched on the primary side only. Noncompliance may damage the LED or reduce its lifetime.

Refer to Application Notes

Specifications (typical at 25°C and after warm up time unless otherwise specified)

Efficiency at Full Load		see table	
Isolation Voltage (60Hz RMS)	input to output	3.75kVAC / 1 minute	
	input to filter ground	1880VAC / 1 minute	
	output to filter ground	500VAC / 1 minute	
Temperature Coefficient	All Versions	±0.02%/°C typ.	
Overload Protection	All Versions	105% typ.	
Short Circuit Protection		Continuous, Hiccup, Automatic Restart	
Open Circuit Output Voltage	4200mA	19VDC	
(Zener Diode Clamp)	2400mA	25VDC	
Typical Values	2100mA/1400mA	29VDC	
	1050mA/700mA	55VDC	
Output Current Adjust (/TOF only)	External Voltage (1-10V)	10.5V max.	
	External PWM (10V)	300Hz max.	
Operating Temperature Range (refer to derating graphs)	free air convection, with derating	-30°C to +70°C	
	Case temperature (/IP67)	85°C max.	
Storage Temperature Range		-40°C to +85°C	
Humidity	non-condensing	95% RH max.	
Environmental Protection	Open Frame (/OF, /TOF)	Indoor Use Only	
	Potted Version (/IP67)	IP67	
PCB Material		Plastic Resin with Fibreglass (UL94V-0)	
Weight	Open Frame (/OF, /TOF)	165g	
	Potted Version (/IP67)	200g	
Packing Quantity		1pc	
EMC		EN 55015, EN61347-1, EN61347-2-13	
Harmonics		Certified to meet EN 61000-3-2 (Class C, Full load) and EN 61000-3-3	
MTBF (using MIL-HDBK-217F, 25°C)		583 x 10 ³ hours	
Safety Standards	LED Lighting Safety	Report: E34696	UL8750
	LED Lighting Safety (Canada)	Report: E34696	cUL8750
	Class 2 Power Supply Safety	Report: E34696	UL1310
	Extra Low-Voltage Class 2 Output	Report: E34696	CSA C22.2 No. 223-M91
	LED equipment for lighting application	Report: E34696	CSA C22.2 No. 250.13-12
	CE LVD Directive -all models		EN61347
Input/Output Connections	/OF Pin Header (suitable matching connector JST VHR or similar)	/IP67 340mm Cable ± 20mm	

/TOF Output Current Adjustment

The /TOF offers the possibility to derate the output current with an external voltage or PWM signal.

Thermal feedback derating is an effective way to reduce the LED current at high temperatures to avoid over-stressing the LED.

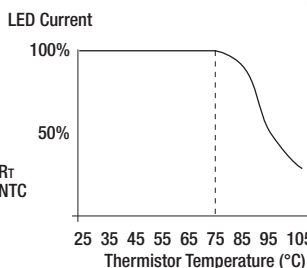
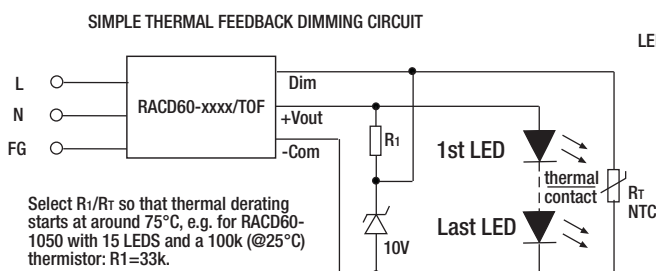
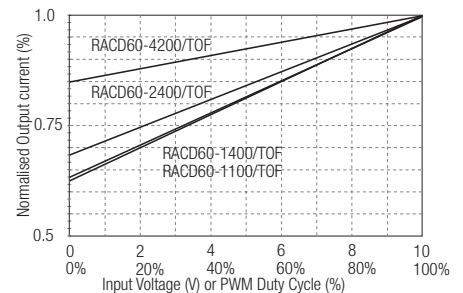

Package Style and Pinning

RACD60-xxxx/OF and RACD60-xxxx/TOF

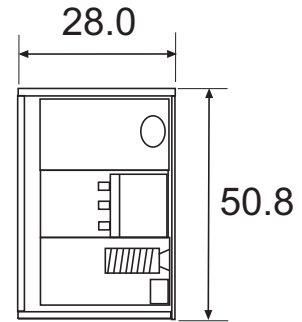
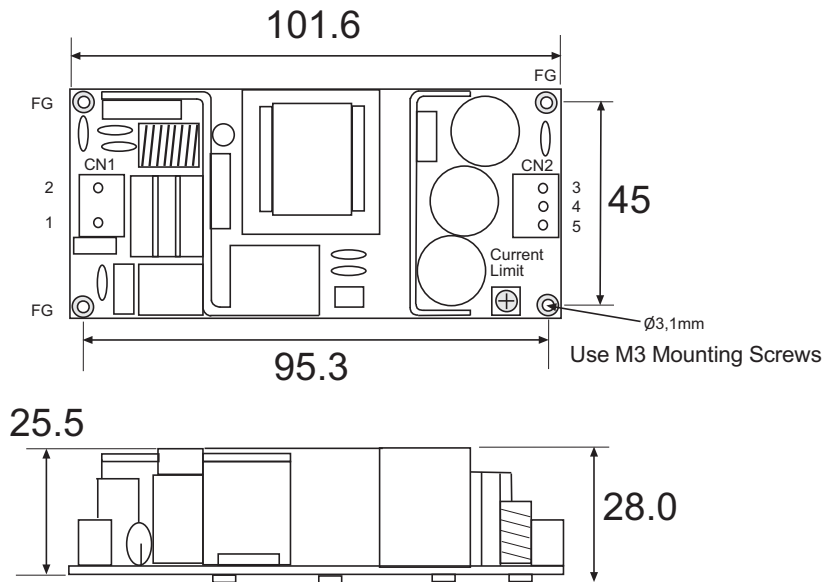

Pin Connections

Pin #	/OF	/TOF
1	VAC in (L)	VAC in (L)
2	VAC in (N)	VAC in (N)
3	NC	Thermal feedback
4	+VDC Out	+VDC Out
5	-VDC Out	Com

Filter Ground connection via mounting holes
Dimension Tolerance $\pm 0.25\text{ mm}$

Package Style and Pinning

RACD60-xxxx/IP67

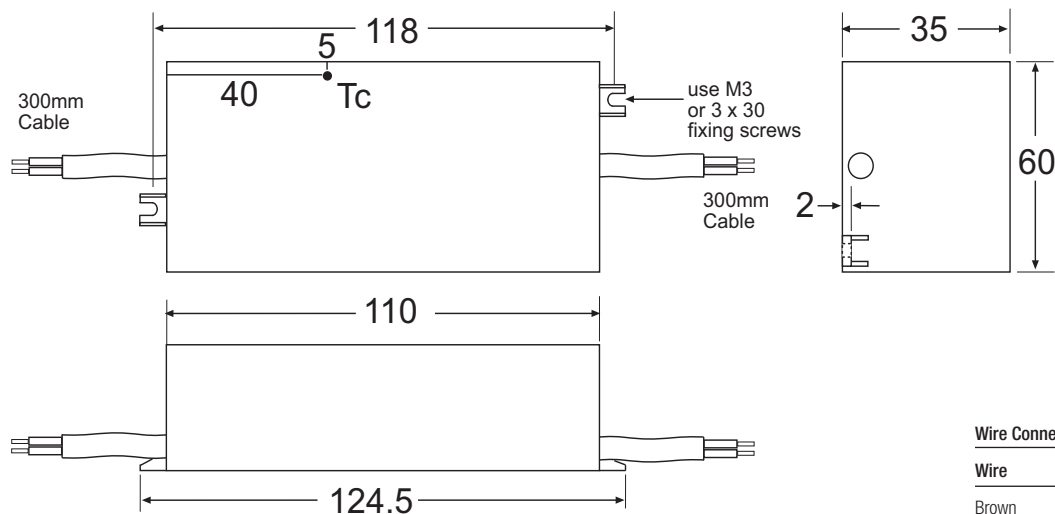

Wire Connections

Wire	Function
Brown	VAC in (L)
Blue	VAC in (N)
Red	+VDC Out
Black	-VDC Out

Dimension Tolerance $\pm 0.25\text{ mm}$

Derating Graphs

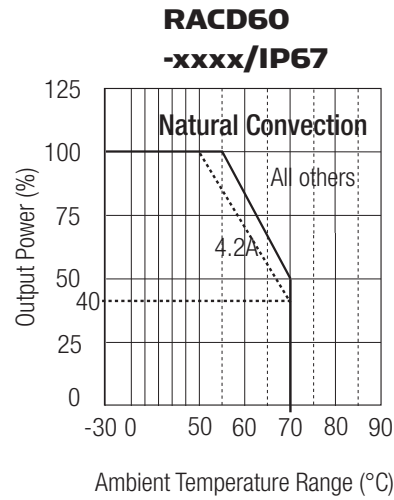
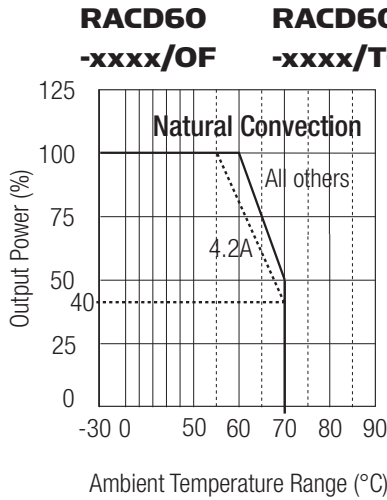

Application Information

LEDs are typically wired in series to make a string of LEDs and then the strings can be wired in parallel to generate enough light. If only two or three strings are wired in parallel then it is recommended to add resistors (e.g. 0.5R) to each string to help balance out the LED currents in each string. All strings must share a common heatsink for better current matching.

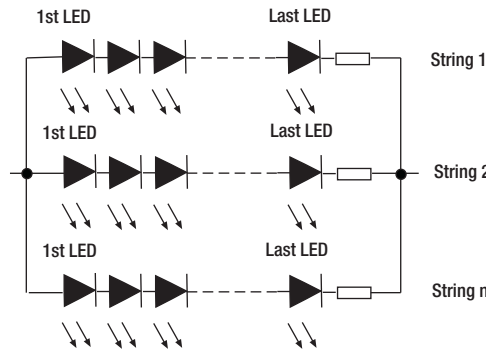

A typical 1W high brightness white LED has a forward voltage of around 3.3V at its operating temperature and draws 350mA. Thus each LED actually draws about 1.15W. Similarly, 3W white LEDs have usually the same forward voltage but can be run at 700mA or more. Using the LED datasheet specification, the optimum LED arrangement and the best driver for each application can be worked out.

The tables below show some examples. Other LED combinations may have different forward voltages at their recommended operating currents.

1W LEDs	LED Arrangement	AC/DC Driver
24	2 Strings of 12	RACD60-700
26	2 Strings of 13	RACD60-700
28	4 Strings of 7	RACD60-1400
30	3 Strings of 10	RACD60-1050
33	3 Strings of 11	RACD60-1050
35	5 Strings of 7	RACD60-2100
35	7 Strings of 5	RACD60-2400
36	3 Strings of 12	RACD60-1050
39	3 Strings of 13	RACD60-1050
42	3 Strings of 14	RACD60-1050
42	7 Strings of 6	RACD60-2400
42	14 Strings of 3	RACD60-4200
45	3 Strings of 15	RACD60-1050

3W LEDs	LED Arrangement	AC/DC Driver
12	12 in series	RACD60-700
14	2 Strings of 7	RACD60-1400
18	3 Strings of 6	RACD60-2100
18	6 Strings of 3	RACD60-4200

High Power LEDs	LED Arrangement	AC/DC Driver
Cree CXA2011	Single Array	RACD60-1050
Cree XM-L	6 in series	RACD60-2100
Lumiled Rebel	13 in series	RACD60-700
Osram Dragon	14 in series	RACD60-1050
Bridgelux RS	Single Array	RACD60-2100
Helieon	Single Module	RACD60-1400

The product information and specifications are subject to change without prior notice. All products are designed for non-safety critical commercial and industrial applications. The Buyer agrees to implement safeguards that anticipate the consequences of any failures that might cause harm, loss of life and/or damage property.

Features

LED DRIVER

- Universal AC Input
- Constant Current Operation
- Suitable for High Brightness LED Products
- Built-In Active PFC Function
- Overvoltage-, Short Circuit- and Over-temperature Protection
- Built-In 3 in 1 Dimming
- IP67 Rated
- Class 2 Power Unit UL1310

Selection Guide

Part Number	Output Voltage (VDC)	Rated Power (W)	Rated Current (mA)	Output Voltage Range (V)	Efficiency (typ.)
RACD60-4200A	12	50	420 - 4200	9 - 12	86%
RACD60-2500A	24	60	250 - 2500	15 - 24	86%
RACD60-1650A	36	60	165 - 1650	24 - 36	87%
RACD60-1200A	48	58	120 - 1200	33 - 48	88%
RACD60-1050A	57	60	105 - 1050	40 - 57	88%

Specifications (measured at 230VAC and 25°C ambient temperature)

Input Voltage Range	90-305 VAC	
Input Frequency Range	47-63Hz	
Power Factor (Full Load)	120VAC	>0.98
	240VAC	>0.94
	277VAC	>0.92
THD	Full Load, 115VAC	12% max.
	Full Load, 230VAC	18% max.
DC Dimming	DC 1-10V	
PWM Dimming	Puls: Hi=10V Low=0V, Duty: 10% - 100%, Fsw 0.5 - 3KHz	
Resistance Dimming	10K - 100K Ω	
Current Accuracy	±5%	
AC Input Current	100-240VAC	0.8A
	277VAC	0.4A
Inrush Current (Cold Start)	240VAC	70A
Leakage Current	<0.5mA / 240VAC	
Start-up Time (at Full Load)	<2sec	
Isolation Voltage	3.75kVAC / 1 minute	
Short Circuit Protection	Hiccup	
Over Voltage Protection	12V	13.2 - 15.6V
	24V	26.4 - 31.2V
	36V	39.6 - 46.8V
	48V	52.8 - 62.4V
	57V	62.7 - 70V
Over Temperature Protection		105 ± 10°C
	Type	Latch Mode
Vibration	10-500Hz, 2G, 60 Min. along X, Y and Z	
Storage Humidity	10% - 90% RH	
Operating Humidity	20% - 90% RH Non-Condensing	
Weight	420g	
Operating Temperature	-30°C to +50°C	
Storage Temperature	-40°C to +60°C	
Ripple & Noise	12V, 24V	200mV
	(at 20MHz bandwidth using 0.1uF & 47uF capacitor)	36V, 48V, 57V
IP Rating	IP67	
Isolation Resistance	100MΩ / 500VDC at 25°C	
Dimension (L*W*H)	179*45.1*32.5mm	

continued on next page

LIGHTLINE

AC/DC-Converter
with 5 year Warranty

RECOM

60 Watt PFC Single Output



EN 61347-1 Certified
EN 61347-2-13 Certified
UL8750 Certified

RACD60-A

Derating-Graph (Ambient Temperature)

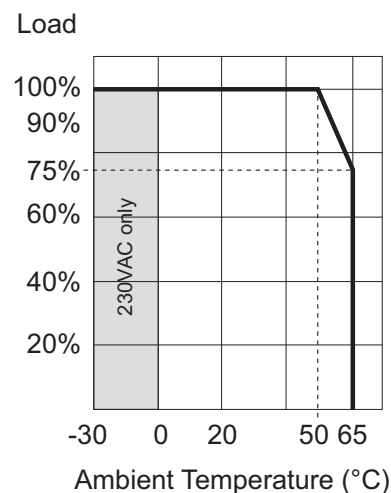

Refer to Application Notes

Specifications (measured at 230VAC and 25°C ambient temperature)

Safety Standards	LED Lighting Safety	Report: E340696	UL8750
	LED Lighting Safety (Canada)	Report: E340696	cUL8750
	Class 2 Power Supply Safety	Report: E340696	UL1310
	Extra Low-Voltage Class 2 Output	Report: E340696	CSA C22.2 No. 223-M91
	LED equipment for lighting application	Report: E340696	CSA C22.2 No. 250.13-12
			EN61347-1
			EN61347-2-13
			EN61000-3-2 Class C
			EN61000-3-3
			EN61000-4-2,3,4,5,6,8,11
			EN61547
			EN55015 FCC15
Design Lifetime			70 x 10 ³ hours max.
MTBF (+25°C)	using MIL-HDBK 217F		200 x 10 ³ hours min.

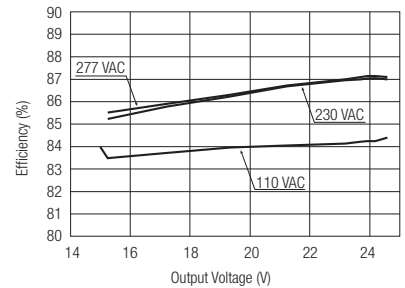

Efficiency vs Load vs Vin
RACD60-2500A

3 in 1 Dimming Control (DC / PWM / Resistance)

10K-100K Resistor Dimmable (Typical):

Resistor	Single-Driver	10K	20K	30K	40K	50K	60K	70K	80K	90K	100K
	Multi-Driver	10K/N	20K/N	30K/N	40K/N	50K/N	60K/N	70K/N	80K/N	90K/N	100K/N
	out (%)	10%	20%	30%	40%	50%	60%	70%	80%	90%	100%

The length of extended wire for DIM+/- shall not exceed 20 meters. (wire ≤ 20m)

N = The number of dimmer drivers should not exceed 15. (N ≤ 15mS)

DC: 1-10V Dimmable (Typical)

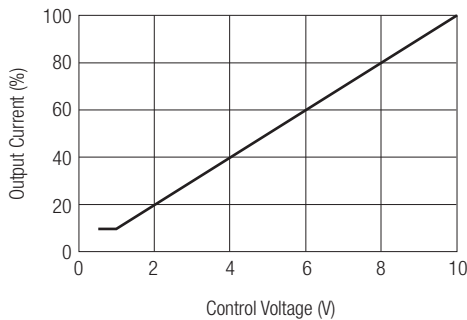

DC: 10V / PWM Dimmable (Typical)

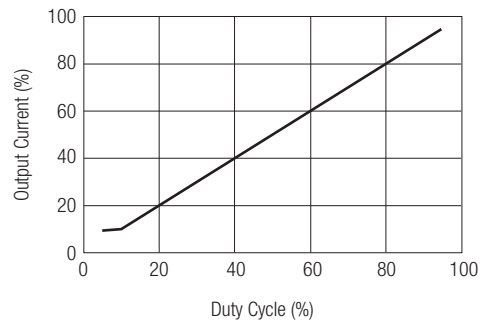

Package Style & Pinning

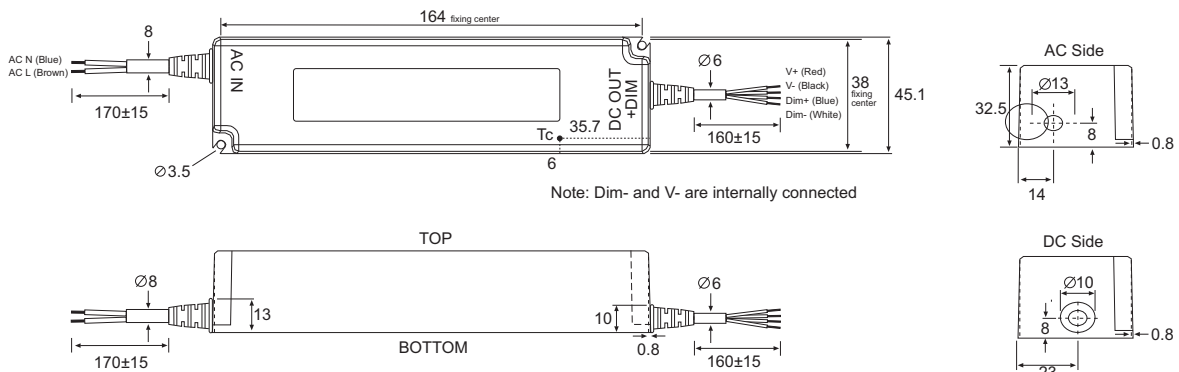

The product information and specifications are subject to change without prior notice. All products are designed for non-safety critical commercial and industrial applications. The Buyer agrees to implement safeguards that anticipate the consequences of any failures that might cause harm, loss of life and/or damage property.

Features

LED DRIVER

- Universal AC Input
- Constant Voltage / Constant Current Operation
- CE and UL Certified Class I LED Driver
- Active Power Factor Correction
- IP67 Design for Indoor and Outdoor Use
- Cooling by Free Air Convection

Selection Guide

Part Number	CV Mode		CC Mode		Efficiency (230VAC) (%)
	Constant Voltage (V)	Current Range (A)	DC Voltage Range (V)	Constant Current (A)	
RACD100-12	12	0-8.3	9-12	8.3	88
RACD100-24	24	0-4.2	14-24	4.2	90
RACD100-36	36	0-2.8	26-36	2.8	90
RACD100-48	48	0-2.1	34-48	2.1	91

Specifications

Input Voltage Range	90-305 VAC or 127-430VDC	
Input Frequency Range	47-63Hz.	
Power Factor	Full Load, 115VAC	>0.98
	Full Load, 230VAC	>0.95
	Full Load, 277VAC	>0.94
THD	Full Load, 115VAC	8% max.
AC Current	115VAC	0.7A max.
	230VAC	1.4A max.
Input/Output Isolation	3.75kVAC / 1minute	
Input/Case Isolation	1.8kVAC / 1minute	
Output/Case Isolation	0.5kVAC / 1minute	
Leakage Current	240VAC	<0.75mA
Voltage Tolerance	-1% to 5%	
Start-up Time (@ Full Load)	115VAC	1.5s
	230VAC / 277VAC	0.7s
Ripple & Noise	48V Version	200mV max.
	others	150mV max.
Over Current Protection	95%-105% rated current	Auto-Recovery
Short Circuit Protection	Hiccup Mode	
Over Voltage Protection	12V	15V typ.
Latch Mode	24V	31V typ.
(Power off to recover)	36V	45V typ.
	48V	58V typ.
Over Temperature Protection	Tcase 95°C ±10°C	
Operating Temperature Range (free air convection, according to CE/UL)	Ambient Temperature	-20°C to +60°C
	Case Temperature	90°C max.
Operation Humidity	20%-90% RH Non-Condensing	
Storage Temperature	-40°C to +80°C	
Storage Humidity	10%-90% RH	
Vibration	10-500Hz, 2G, 60 Min. along X, Y and Z	
IP Rating	IP67	
Safety Standards	UL/cUL LED Lighting Safety (E340696)	UL8750
	CE LVD Directive, Safety	EN61347-2-13
	CB Report: 12CA61289-1	IEC61347-2-13
EMC Standards	EMC Compatibility	EN55015
		FCC, Part 15
	Harmonic Current	EN61000-3-2 Class C (≥75% load)
		EN61000-3-3
	EMC Immunity	EN61000-4-2, 3, 4, 5, 6, 11

continued on next page

LIGHTLINE

AC/DC-Converter
with 5 year Warranty

RECOM

100 Watt Single Output

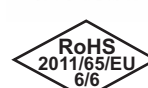

UL 8750 Certified
EN 61347 Certified

RACD100

Note:

All LED Drivers may not be used without a load. They must be switched on the primary side only. Noncompliance may damage the LED or reduce its lifetime.

Refer to Application Notes

Specifications

Dimension	222*68*39mm	
Weight	1020g	
MTBF	using MIL-HDBK-217F (25°C)	250 x 10 ³ hours
Design Lifetime	70 x 10 ³ hours	

The use of a circuit breaker with C-characteristic is recommended.

Derating Curve

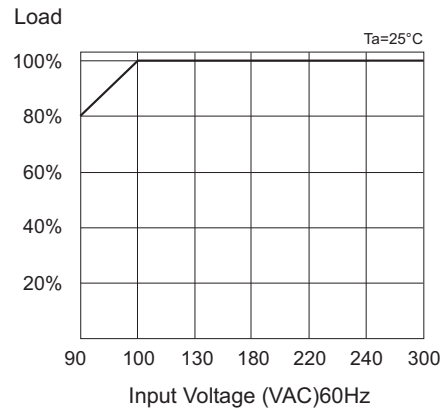
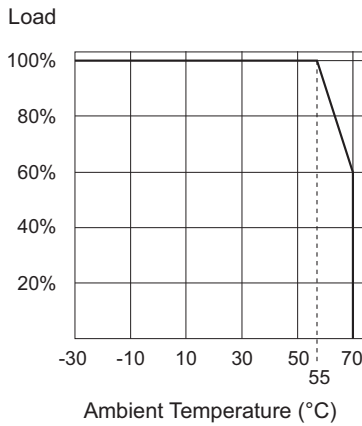

Characteristics

Constant Voltage / Constant Current Curve

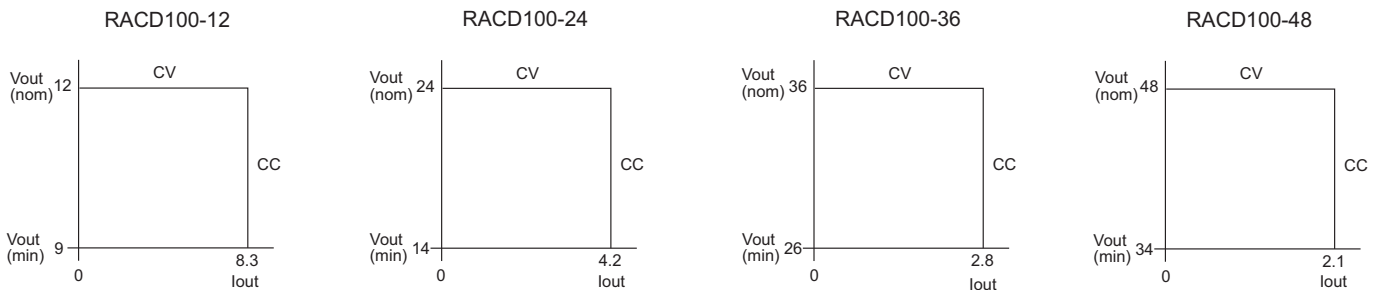

RACD100

Package Style and Pinning

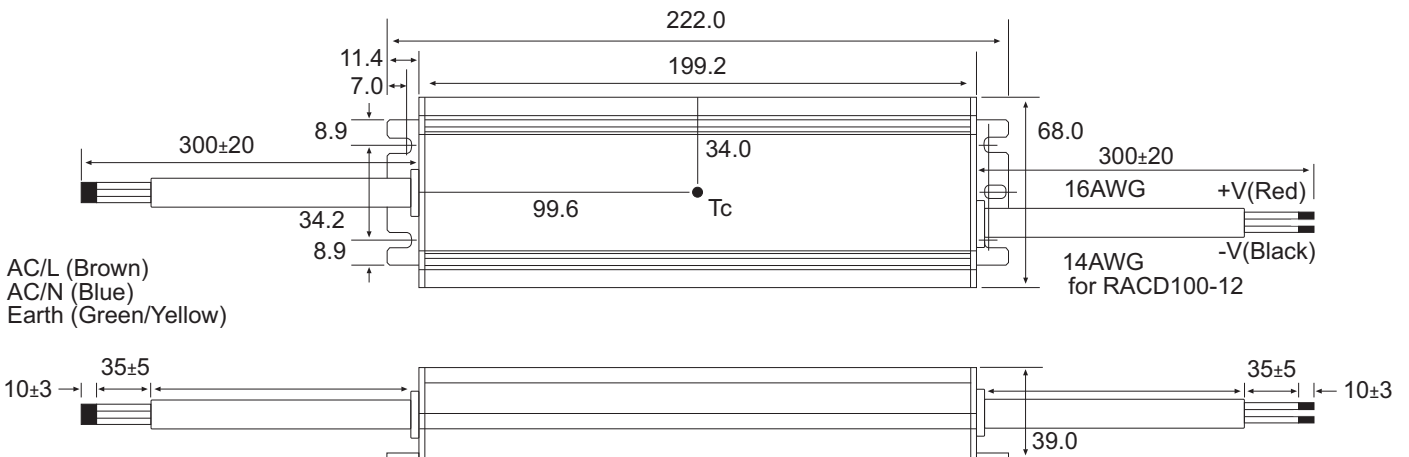

The product information and specifications are subject to change without prior notice. All products are designed for non-safety critical commercial and industrial applications. The Buyer agrees to implement safeguards that anticipate the consequences of any failures that might cause harm, loss of life and/or damage property.

Features

LED DRIVER

- Universal AC Input
- Constant Voltage / Constant Current Operation
- CE and ENEC Certified Class I LED Driver
- Active Power Factor Correction
- IP67 Design for Indoor and Outdoor Use
- Cooling by Free Air Convection

Selection Guide

Part Number	CV Mode		CC Mode		Efficiency (230VAC) (%)
	Constant Voltage (V)	Current Range (A)	DC Voltage Range (V)	Constant Current (A)	
RACD100-12-ENECE	12	0-8.3	9-12	8.3	88
RACD100-24-ENECE	24	0-4.2	14-24	4.2	90
RACD100-36-ENECE	36	0-2.8	26-36	2.8	90
RACD100-48-ENECE	48	0-2.1	34-48	2.1	91

Specifications

Input Voltage Range	90-305 VAC or 127-430VDC	
Input Frequency Range	47-63Hz.	
Power Factor	Full Load, 115VAC	>0.98
	Full Load, 230VAC	>0.95
	Full Load, 277VAC	>0.94
THD	Full Load, 115VAC	8% max.
AC Current	115VAC	0.7A max.
	230VAC	1.4A max.
Input/Output Isolation	3.75kVAC / 1 minute	
Input/Case Isolation	1.8kVAC / 1 minute	
Output/Case Isolation	0.5kVAC / 1 minute	
Leakage Current	240VAC	<0.75mA
Voltage Tolerance	-1% to 5%	
Start-up Time	115VAC	1.5s
(@ Full Load)	230VAC / 277VAC	0.7s
Ripple & Noise	48V Version	200mV max.
	others	150mV max.
Over Current Protection	95%-105% rated current	Auto-Recovery
Short Circuit Protection	Hiccup Mode	
Over Voltage Protection	12V	15V typ.
Latch Mode	24V	31V typ.
(Power off to recover)	36V	45V typ.
	48V	58V typ.
Over Temperature Protection	Tcase 95°C ±10°C	
Operating Temperature Range	Ambient Temperature	-20°C to +50°C
(free air convection, according to ENEC)	Case Temperature	75°C max.
Operation Humidity	20%-90% RH Non-Condensing	
Storage Temperature	-40°C to +80°C	
Storage Humidity	10%-90% RH	
Vibration	10-500Hz, 2G, 60 Min. along X, Y and Z	
IP Rating	IP67	
Safety Standards	RCM (U21457)	AS/NZS 61347.1:2002
	ENEC General Safety	CB Report: IEC 61347-1: 2008
	ENEC Safety of AC Control Gear for LED Modules	CB Report: IEC 61347-2-13: 2006
EMC Standards	EMC Compatibility	EN55015
		FCC, Part 15
	Harmonic Current	EN61000-3-2 Class C (≥75% load)
		EN61000-3-3
	EMC Immunity	EN61000-4-2, 3, 4, 5, 6, 11
Performance Standard	controlgear for LED modules	CB Report: IEC 62384:2006
Dimension	222*68*39mm	
Weight	1020g	
MTBF	using MIL-HDBK-217F (25°C)	250 x 10 ³ hours
Design Lifetime	70 x 10 ³ hours	

The use of a circuit breaker with C-characteristic is recommended.

LIGHTLINE

AC/DC-Converter

with 5 year Warranty

RECOM

100 Watt Single Output



EN 61347 Certified
EN 62384 Certified

RACD100-ENECE

Note:

All LED Drivers may not be used without a load. They must be switched on the primary side only. Noncompliance may damage the LED or reduce its lifetime.

Refer to Application Notes

Derating Curve

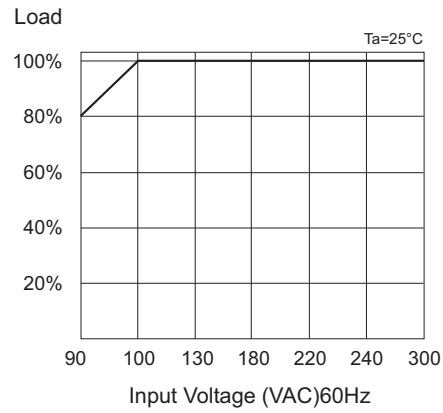
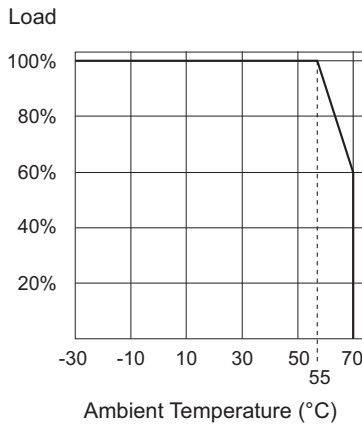

Characteristics

Constant Voltage / Constant Current Curve

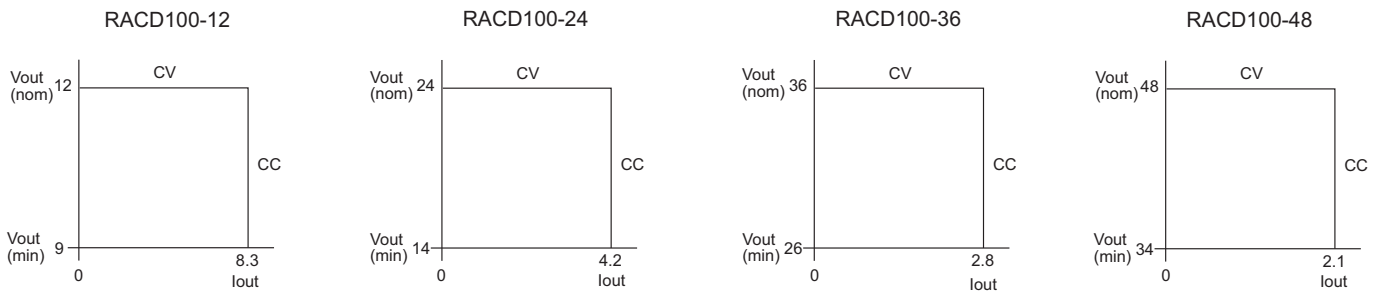

Package Style and Pinning

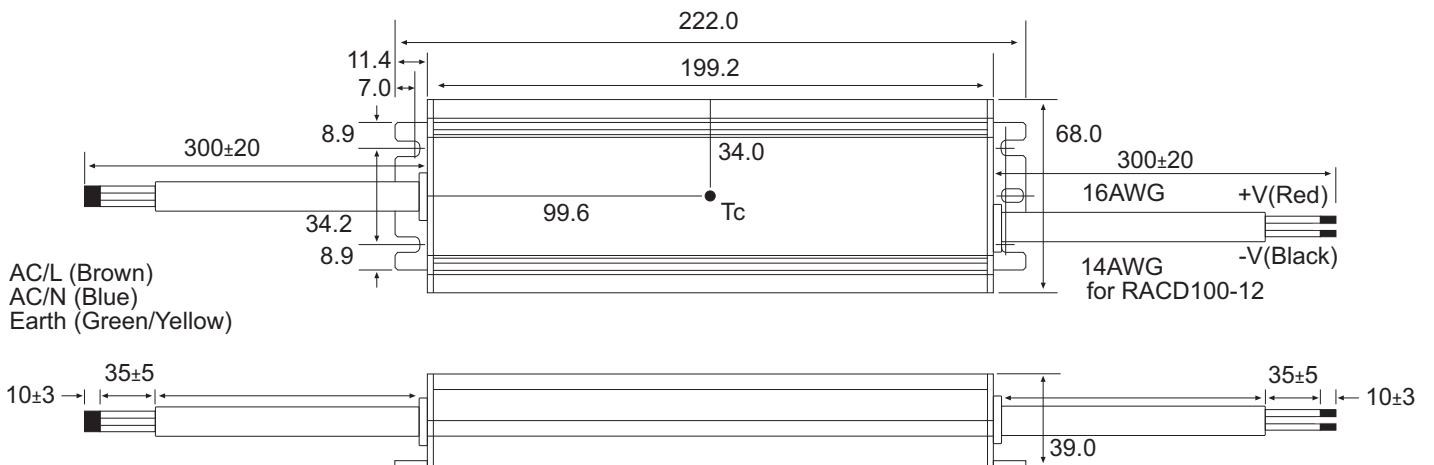

RACD100

Features

LED DRIVER

- High Output Voltage
- Universal AC Input
- Constant Current Operation
- Active Power Factor Correction
- IP67 Design for Indoor and Outdoor Use
- Compact Size
- Digital PWM and Analogue Voltage Dimming

Selection Guide

Part Number	Nominal Voltage (VAC)	Rated Voltage (V)	Output Voltage Range (VDC)	Rated Current (mA)	Efficiency (%)
RACD100-700A	100-277	142	100-142	700	91
RACD100-1400A	100-277	71	50-71	1400	91

Specifications (measured at 240V AC and 25°C ambient temperature)

2/ Input Voltage Range	90-305 VAC or 127-430VDC	
Input Frequency Range	47-63Hz	
Power Factor	Full Load, 115VAC	>0.98
	Full Load, 230VAC	>0.94
	70% Load	>0.90
DC Dimming	Open = 100%	DC 1-10V
PWM Dimming	Open = 100%	Duty 10% - 100%
	Freq.	500Hz - 3000Hz
	Voltage	Hi=10V, Low=0V
THD	Full Load, 115VAC	8% max.
	Full Load, 230VAC	15% max.
	Full Load, 277VAC	17% max.
AC Current	115VAC	1.2A max.
	230VAC	0.6A max.
Input/Output Isolation	3.75kVAC / 1minute	
Input/Case Isolation	1.8kVAC / 1minute	
Output/Case Isolation	0.5kVAC / 1minute	
Leakage Current	230VAC	<0.75mA
Inrush Current	230VAC	50A
(Class C Circuit Breaker is recommended)		
Voltage Tolerance	-1% to 5%	
Current Tolerance	±5%	
Start-up Time (@ Full Load)	230VAC	2s
Ripple & Noise	142V Version	1000mV max.
(@20MHz bandwidth)	71V Version	500mV max.
Over Voltage	110 - 140% Rated Voltage	Shutdown Mode
Short Circuit Protection	Hiccup Mode	
Over Temperature Protection	100°C ±10°C	
Operation Temperature	(Refer to Output Load Derating Curve) -30°C to +55°C	
Operation Humidity	20%-90% RH Non-Condensing	
Storage Temperature	-40°C to +80°C	
Storage Humidity	10%-95% RH	
Vibration	10-500Hz, 2G, 60 Min. along X, Y and Z	
IP Rating	IP67	
Safety Standards	UL/cUL LED Lighting Safety	UL8750
	CE LVD Directive, Safety	EN61347-2-13
	CB Report: 1103631 001	IEC61347-2-13

continued on next page

LIGHTLINE
AC/DC-Converter
with 5 year Warranty

RECOM

**100 Watt
Single
Output**



**UL 8750 Certified
EN 61347 Certified**

RACD100-A

Derating Graph

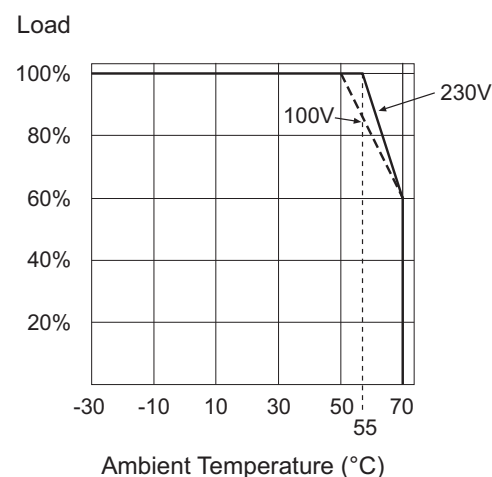

Refer to Application Notes

LIGHTLINE

AC/DC-Converter

RACD100-A

Series

Specifications (measured at 240V AC and 25°C ambient temperature)

EMC Standards	EMC Compatibility	EN55015
		FCC, Part 15
	Harmonic Current	EN61000-3-2 Class C
		EN61000-3-3
	EMC Immunity	EN61000-4-2, 3, 4, 5, 6, 11
		EN61547
Dimension		177*57*37mm
Weight		750g
Design Lifetime		70 x 10 ³ hours max.
MTBF	using MIL-HDBK-217F (25°C)	200 x 10 ³ hours min.

Note:

All LED Drivers may not be used without a load. They must be switched on the primary side only. Noncompliance may damage the LED or reduce its lifetime.

Derating Curve

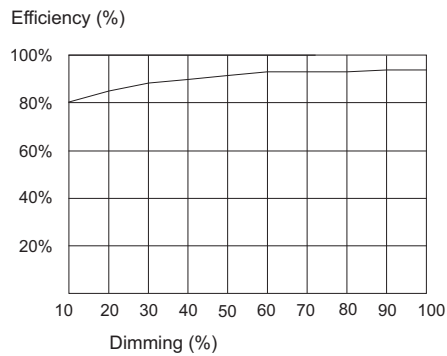
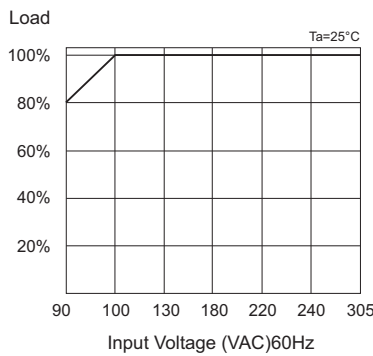

DC Voltage Dimming Curve

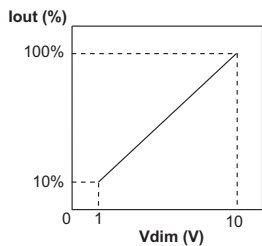

Note: Resistor dimming is only possible with a digital potentiometer (current sink), like the RECOM REPOT

PWM Dimming Curve

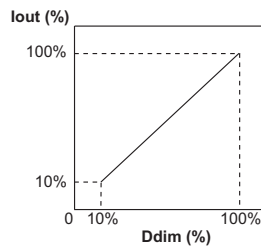

Pule: Hi = 10V, Low = 0V
Frequency: 500 - 3KHz

Package Style and Pinning

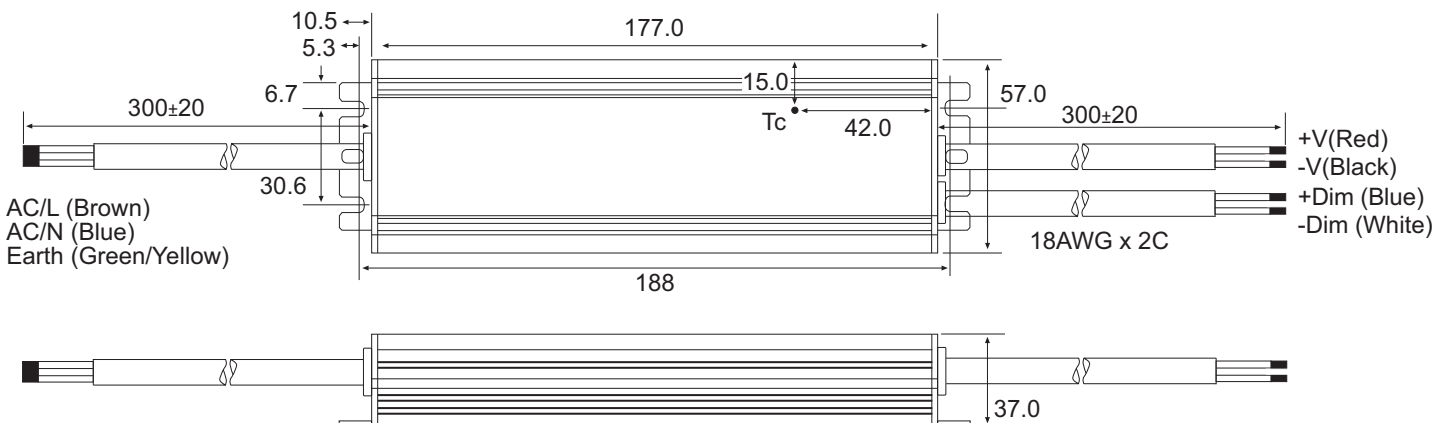

The product information and specifications are subject to change without prior notice. All products are designed for non-safety critical commercial and industrial applications. The Buyer agrees to implement safeguards that anticipate the consequences of any failures that might cause harm, loss of life and/or damage property.

Features

LED DRIVER

- Universal AC Input
- Constant Voltage / Constant Current Operation
- CE and UL Certified Class I LED Driver
- Active Power Factor Correction
- IP67 Design for Indoor and Outdoor Use
- Cooling by Free Air Convection

Selection Guide

Part	CV Mode		CC Mode		Efficiency (230VAC) (typ.)
	Constant Voltage (V)	Current Range (A)	DC Voltage Range (V)	Constant Current (A)	
RACD150-12	12	0-11	9-12	11	88%
RACD150-24	24	0-6.3	14-24	6.3	90%
RACD150-36	36	0-4.2	26-36	4.2	90%
RACD150-48	48	0-3.2	34-48	3.2	90%

Specifications

Input Voltage Range	90-305 VAC or 127-430VDC	
Input Frequency Range	47-63Hz.	
Power Factor	Full Load, 115VAC	>0.98
	Full Load, 230VAC	>0.95
	Full Load, 277VAC	>0.94
THD	Full Load, 115VAC	8% max.
AC Current	115VAC	2A max.
	230VAC	1A max.
Input / Output Isolation	3.75kVAC / 1minute	
Input / Case Isolation	1.8kVAC / 1minute	
Output / Case Isolation	0.5kVAC / 1minute	
Leakage Current	230VAC	<0.5mA
Current Tolerance	±5%	
Voltage Tolerance	-1% to 5%	
Start-up Time	115VAC	1.0s
(@ Full Load)	230VAC / 277VAC	0.8s
Ripple & Noise	48V Version	200mV max.
	others	150mV max.
(with 20MHz bandwidth & 47µF Elco + 0.1µF MLCC)		
Over Current Protection	95%-105% rated current	Auto-Recovery
Short Circuit Protection	Hiccup Mode	
Over Voltage Protection	12V	12.5V typ.
Latch Mode	24V	24.5V typ.
(Power off to recover)	36V	36.5V typ.
	48V	48.5V typ.
Over Temperature Protection	Tcase 95°C ±10°C	
Operating Temperature Range	Ambient Temperature	-20°C to +60°C
(free air convection, according to CE/UL)	Case Temperature	90°C max.
Operation Humidity	20%-90% RH Non-Condensing	
Storage Temperature	-40°C to +80°C	
Storage Humidity	10%-90% RH	
Vibration	10-500Hz, 2G, 60 Min. along X, Y and Z	
IP Rating	IP67	
Safety Standards	UL/cUL LED Lighting Safety (E340696)	cUL8750
	CE LVD Directive, Safety	EN61347-2-13
	CB Report: 12CA61289-1	IEC61347-2-13
EMC Standards	EMC Compatibility	EN55015
		FCC, Part 15
	Harmonic Current	EN61000-3-2 Class C (≥75% load)
		EN61000-3-3
	EMC Immunity	EN61000-4-2, 3, 4, 5, 6, 11
Dimension	199.2*68*39mm	
Weight	1080g	
MTBF	using MIL-HDBK-217F (25°C)	200 x 10 ³ hours
Design Lifetime	70 x 10 ³ hours	

LIGHTLINE

AC/DC-Converter
with 5 Year Warranty

RECOM

150 Watt Single Output



UL 8750 Certified
EN 61347 Certified

RACD150

Note:

The use of a circuit breaker with C-characteristic is recommended.

All LED Drivers may not be used without a load. They must be switched on the primary side only. Noncompliance may damage the LED or reduce its lifetime.

Refer to Application Notes

Derating Curve

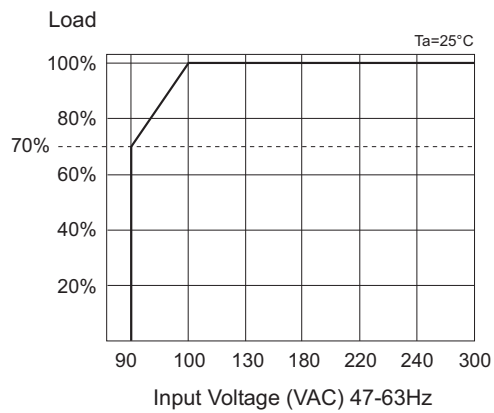
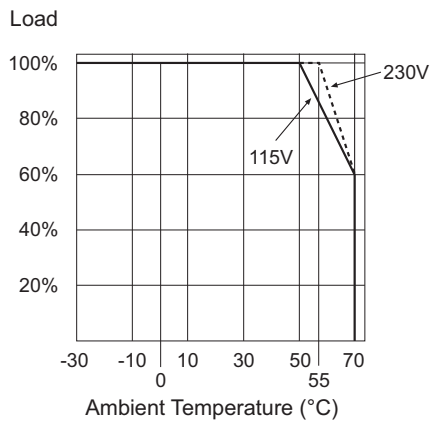

Characteristics

Constant Voltage / Constant Current Curve

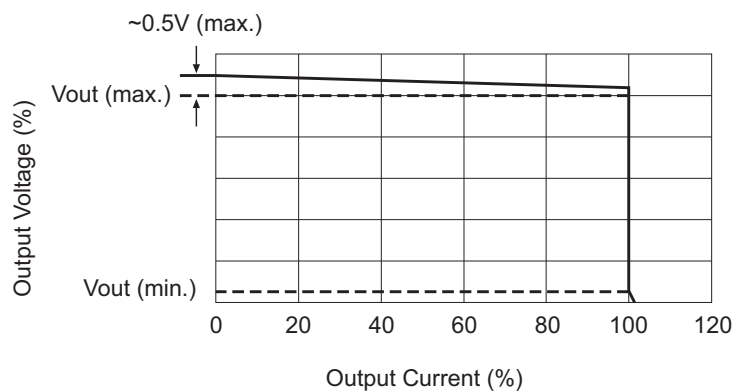

Package Style and Pinning

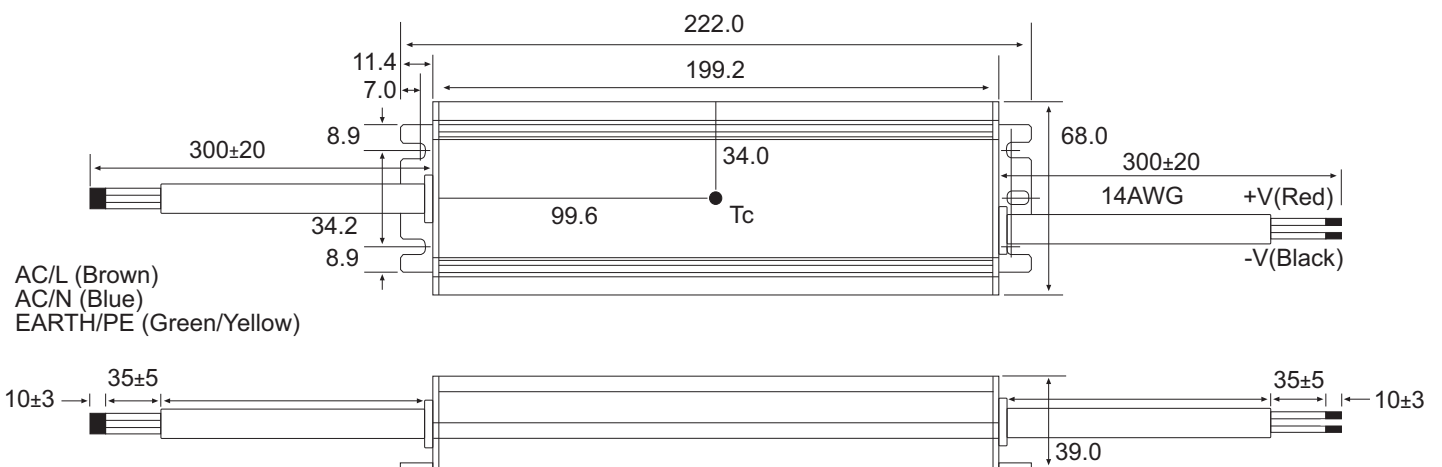

Features

LED DRIVER

- Universal AC Input
- Constant Voltage / Constant Current Operation
- CE and ENEC Certified Class I LED Driver
- Active Power Factor Correction
- IP67 Design for Indoor and Outdoor Use
- Cooling by Free Air Convection

Selection Guide

Part	CV Mode		CC Mode		Efficiency (230VAC) (typ.)
	Constant Voltage (V)	Current Range (A)	DC Voltage Range (V)	Constant Current (A)	
RACD150-12-ENECE	12	0-11	9-12	11	88%
RACD150-24-ENECE	24	0-6.3	14-24	6.3	90%
RACD150-36-ENECE	36	0-4.2	26-36	4.2	90%
RACD150-48-ENECE	48	0-3.2	34-48	3.2	90%

Specifications

Input Voltage Range	90-305 VAC or 127-430VDC	
Input Frequency Range	47-63Hz.	
Power Factor	Full Load, 115VAC	>0.98
	Full Load, 230VAC	>0.95
	Full Load, 277VAC	>0.94
THD	Full Load, 115VAC	8% max.
AC Current	115VAC	2A max.
	230VAC	1A max.
Input / Output Isolation	3.75kVAC / 1minute	
Input / Case Isolation	1.8kVAC / 1minute	
Output / Case Isolation	0.5kVAC / 1minute	
Leakage Current	230VAC	<0.5mA
Current Tolerance	±5%	
Voltage Tolerance	-1% to 5%	
Start-up Time	115VAC	1.0s
(@ Full Load)	230VAC / 277VAC	0.8s
Ripple & Noise	48V Version	200mV max.
	others	150mV max.
(with 20MHz bandwidth & 47µF Elco + 0.1µF MLCC)		
Over Current Protection	95%-105% rated current	Auto-Recovery
Short Circuit Protection	Hiccup Mode	
Over Voltage Protection	12V	12.5V typ.
Latch Mode	24V	24.5V typ.
(Power off to recover)	36V	36.5V typ.
	48V	48.5V typ.
Over Temperature Protection	Tcase 95°C ±10°C	
Operating Temperature Range	Ambient Temperature	20°C to +50°C
(free air convection, according to ENEC)	Case Temperature	75°C max.
Operation Humidity	20%-90% RH Non-Condensing	
Storage Temperature	-40°C to +80°C	
Storage Humidity	10%-90% RH	
Vibration	10-500Hz, 2G, 60 Min. along X, Y and Z	
IP Rating	IP67	
Safety Standards	RCM (U21457)	AS/NZS 61347.1:2002
	ENEC General Safety	CB Report: IEC 61347-1: 2008
	ENEC Safety of AC Control Gear for LED Modules	CB Report: IEC 61347-2-13: 2006
EMC Standards	EMC Compatibility	EN55015
		FCC, Part 15
	Harmonic Current	EN61000-3-2 Class C (≥75% load)
		EN61000-3-3
	EMC Immunity	EN61000-4-2, 3, 4, 5, 6, 11
Performance Standard	controlgear for LED modules	CBReport: IEC 62384:2006

continued on next page

LIGHTLINE
AC/DC-Converter
with 5 Year Warranty

RECOM

**150 Watt
Single
Output**



**EN 61347 Certified
EN 62384 Certified**

RACD150-ENECE

Note:

The use of a circuit breaker with C-characteristic is recommended.

All LED Drivers may not be used without a load. They must be switched on the primary side only. Noncompliance may damage the LED or reduce its lifetime.

Refer to Application Notes

LIGHTLINE

AC/DC-Converter

RACD150-ENEC Series

Specifications

Dimension		199.2*68*39mm
Weight		1080g
MTBF	using MIL-HDBK-217F (25°C)	200 x 10 ³ hours
Design Lifetime		70 x 10 ³ hours

Derating Curve

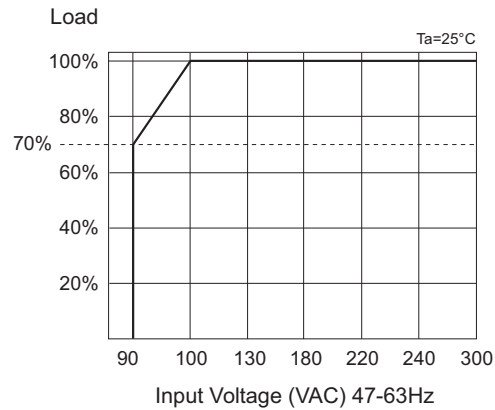
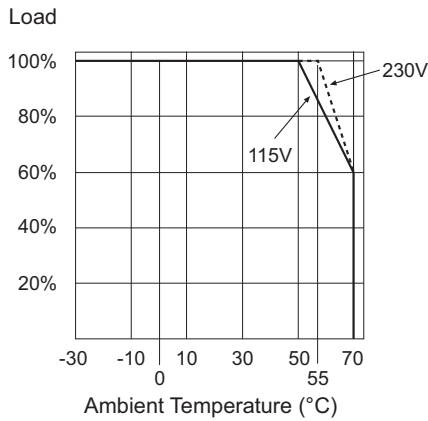

Characteristics

Constant Voltage / Constant Current Curve

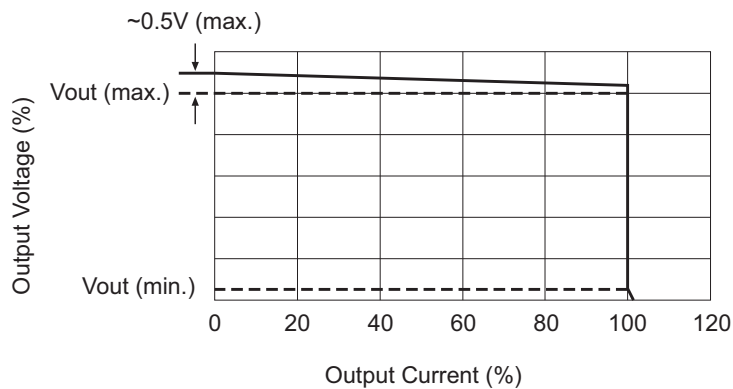

Package Style and Pinning

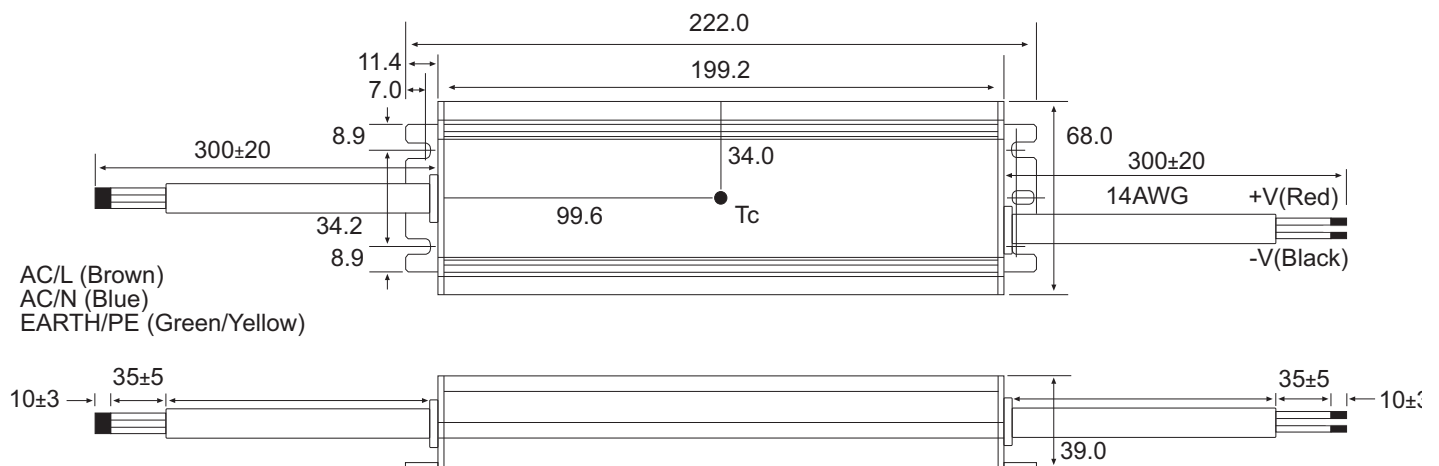

The product information and specifications are subject to change without prior notice. All products are designed for non-safety critical commercial and industrial applications. The Buyer agrees to implement safeguards that anticipate the consequences of any failures that might cause harm, loss of life and/or damage property.

Features

LED DRIVER

- High Output Voltage
- Universal AC Input
- Constant Current Operation
- Active Power Factor Correction
- IP67 Design for Indoor and Outdoor Use
- Compact Size
- Digital PWM and Analogue Voltage Dimming

Description

The new RACD150A LED drivers offer constant output currents of 1400mA, 1050mA or 700mA, with voltages from 60V up to 210V. The series supports dimming via PWM or 1-10V signals and is fully IP67 sealed for outdoor as well as indoor applications. With their wide input voltage range of 90 to 305VAC, the new drivers can be used worldwide on 115Vac, 230Vac and 277Vac supplies. The converters operate with full load efficiencies of more than 93%, feature low THD (15%) and active PFC with power factors exceeding 0.98, and are fully protected against short circuit, overload and over-temperature conditions. Applications include high-power area lighting as well as car parks, warehouse or security lighting. The LED drivers are UL8750 and EN61347 certified, comply with FCC and European EMC standards and come with a full 5 year warranty.

Selection Guide

Part Number	Input Voltage Range (VAC)	Rated Power (W)	Output Voltage Range (VDC)	Rated Output Current (mA)	Efficiency (%)
RACD150-700A	90-305	147	60-210	700	92
RACD150-1050A	90-305	150	60-143	1050	92
RACD150-1400A	90-305	150	60-107	1400	91

Specifications (measured at 230VAC and 25°C ambient temperature)

Input Voltage Range	90-305 VAC or 127-430VDC	
Input Frequency Range	47-63Hz.	
Power Factor	Full Load, 120VAC	>0.98
	Full Load, 240VAC	>0.94
	75% Load, 240VAC	>0.90
DC Dimming	Open = 100%	DC 1-10V
PWM Dimming	Open = 100%	Duty 10% - 100%
	Freq.	500Hz - 3000Hz
	Voltage	Hi=10V, Low=0V
THD (@ 230VAC/50Hz)	700A	±10%
	1050A, 1400A	±11%
Input Current	115VAC	2A max.
	240VAC	1A max.
Input/Output Isolation	3.75kVAC / 1min	
Input/Case Isolation	1.8kVAC / 1min	
Output/Case Isolation	0.5kVAC / 1min	
Leakage Current	230VAC	<0.75mA
Inrush Current	240VAC	cold start 65A max.
Voltage Tolerance	±10%	
Current Tolerance	±5%	
Ripple & Noise (@20MHz bandwidth) ⁽¹⁾	2000mV max.	
Over Voltage Protection	105 - 130% Rated Voltage	Shutdown Mode
Short Circuit Protection	Constant current limit and recovers after fault condition is removed	
Over Temperature Protection	Shutdown Mode	
Operating Temperature Range (Refer to Output Load Derating Curve)	Ambient	-40°C to +55°C
(free air convection)	Case Temperature	100°C max.
Operation Humidity	20%-90% RH Non-Condensing	
Storage Temperature	-40°C to +80°C	
Storage Humidity	10%-95% RH	
Vibration	2G 10min/1Cycle, Period for 60 min	10-500Hz

continued on next page

LIGHTLINE
AC/DC-Converter
with 5 year Warranty

RECOM

**150 Watt
Single
Output**



**UL 8750 Certified
EN 61347 Certified**

RACD150-A

Derating Graph

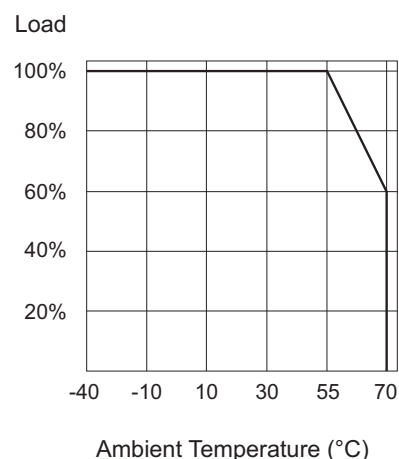

Refer to Application Notes

Specifications (measured at 115VAC / 230VAC and 25°C ambient temperature)

Isolation Resistance	100MΩ / 500VDC at 25°C		
IP Rating	IP67		
Safety Standards	UL/cUL LED Lighting Safety	Report: E340696	UL8750
	CE LVD Directive, Safety	Report: 12CA61289-1	EN61347-2-13
	CB	Report: 11036253 001	IEC61347-2-13
Standards	EMC Compatibility		EN55015
			FCC, Part 15
	Harmonic Current		EN61000-3-2 Class C
			EN61000-3-3
	EMC Immunity		EN61000-4-2, 3, 4, 5, 6, 11
			EN61547
Dimension	226*68*39mm		
Weight	1.1kg		
MTBF	using MIL-HDBK-217F (25°C)	200 x 10 ³ hours	

Notes:

- Note1: Ripple and Noise are measured at 20MHZ bandwidth by using a 12" twisted pair-wire terminated with 0.1uf & 47uf paralell application
 Note2: All LED Drivers may not be used without a load. They must be switched on the primary side only. Noncompliance may damage the LED or reduce its lifetime.

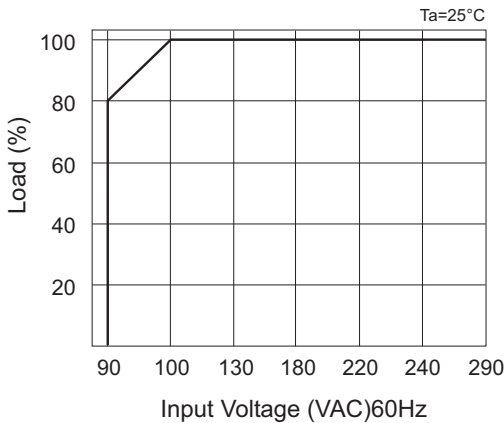

DC Voltage Dimming Curve

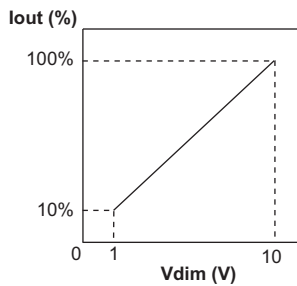

Note: Resistor dimming is only possible with a digital potentiometer (current sink), like the RECOM REPO1

PWM Dimming Curve

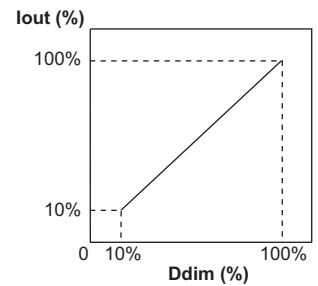

Pule: Hi = 10V, Low = 0V
Frequency: 500 - 3KHz

RACD150-A

Package Style and Pinning

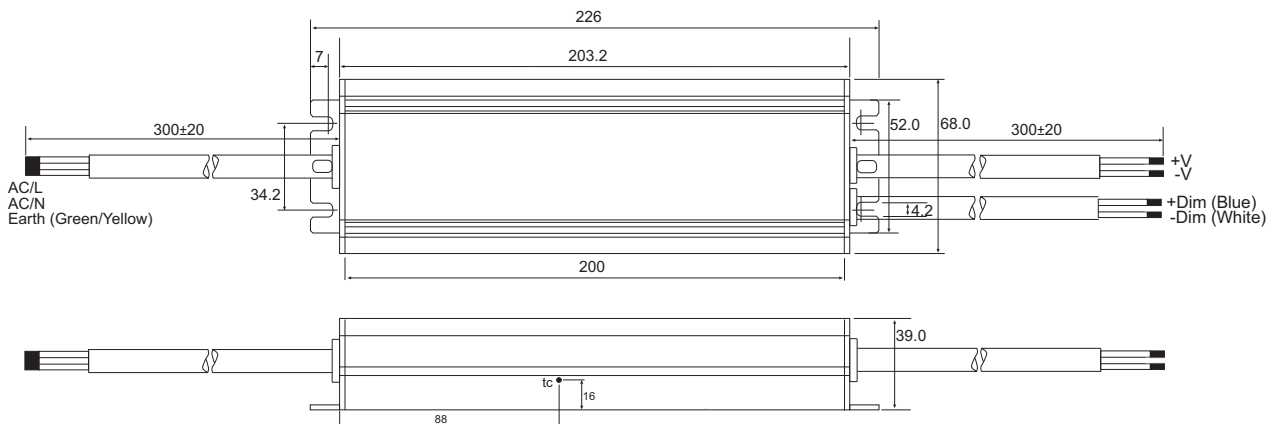

The product information and specifications are subject to change without prior notice. All products are designed for non-safety critical commercial and industrial applications. The Buyer agrees to implement safeguards that anticipate the consequences of any failures that might cause harm, loss of life and/or damage property.

Features

DALI Converter

- Compliant with DALI Standard (IEC62386 Part 102 & Part 206)
- Screw-less Connectors, Easy to Install
- Selectable Output for PWM / DC 0-10V / DC 1-10
- Built-in Relay to Turn ON/OFF Driver Completely (Zero Standby Current)
- Over Voltage and Short Circuit Protection

Description

The RELI-DA01/R is a DALI to analog control signal interface which is compliant with the DALI IEC62386 standard. The output is selectable between PWM and 0-10V or 1-10V and is compatible with all RECOM dimmable LED drivers as well as other manufacturer's products. The output can control six or more LED drivers, allowing the lighting in a whole room or office to be dimmed with just one DALI address. A built-in relay can be used to switch off the LED drivers under software control to give zero no-load consumption.

The interface is AC powered (110VAC or 230VAC) and consumes typically only 1.6W in operation.

Selection Guide

Part Number	Input Voltage (VAC)	Power Consumption (W)	DALI Bus Power Consumption (mA)	DALI Standard IEC62386	Dimming Output
RELI-DA01/R	90-264	1.6 typ.	2 max.	Part-102 Part-206	PWM or DC 0-10V DC 1-10V

Specifications (measured at $T_A = 25^\circ\text{C}$ and nominal input voltage)

Input Voltage Range	90-290VAC 50/60Hz	
Power Consumption	1.6W typ. / 3W max.	
DALI Bus Current Consumption	2mA max.	
Suitable Electric Wire	22 AWG - 16 AWG	
PWM Frequency	500Hz typ.	
PWM High Level Voltage	9.5VDC min. / 10VDC typ. / 10.5VDC max.	
PWM Low Level Voltage	0VDC typ.	
PWM Output Current Sourcing (mA)	-60mA min. / 60mA max.	
DC 0/1-10V Output Accuracy	±3%	
DC Output Current Sourcing (mA)	-5mA min. / 60mA max.	
DALI Standard	IEC62386 Part-102 & Part-206	
Number of Output Channel	1	
Short Circuit Protection	(Dimming Output)	cont.
Over Voltage Protection	(DALI connector)	24V Zener Diode clamp
Operating Temperature Range (free air convection)	Ambient Temperature	-20 to +40°C
	Case Temperature	46°C
Relay Switch	1 Channel, 2A cont. / 7A peak.	
IP Rating	IP20	
Dimensions	150 x 40 x 28mm	
Weight	100g ±10%	
Safety Standards (designed to meet)	EN61347-1 EN61347-2-13 UL8750 EN61000-3-2 Class C EN61000-4-2,3,4,5,6,11, 20 EN61547 EN55015 FCC15	
MTBF (+25°C)	using MIL-HDBK 217F	200 x 10 ³ hours min.

LIGHTLINE DALI-Converter AC/DC with 5 year Warranty

RECOM

1.6 Watt DALI- Converter



IEC 62386-102 Compliant
IEC 62386-206 Compliant

RELI-DA01/R

Refer to Application Notes

Typical Characteristics

DALI Declaration for Factory Variables (for Part 102)

Variable	Default Value	Reset Value	Range of Validity
Actual Dim Level	254	254	0, Min Level - Max Level
Power on Level	254	254	0 - 255 (Mask)
System Failure Level	254	254	0 - 255 (Mask)
Min Level	Physical Min Level	Physical Min Level	Physical Min Level - Max Level
Max Level	254	254	Min Level - 254
Fade Rate	7 (45 steps/s)	7 (45 steps/s)	1-15
Fade Time	0 (no fade)	0 (no fade)	0-15
Short Address	255 (Mask)	no change	0-63 255 (Mask)
Search Address	FF FF FF	FF FF FF	00 00 00 - FF FF FF
Random Address	FF FF FF	FF FF FF	00 00 00 - FF FF FF
Group 0-7	0000 0000 (no group)	0000 0000 (no group)	0 - 255
Group 8-15	0000 0000 (no group)	0000 0000 (no group)	0 - 255
Group 0-15	255 (Mask)	255 (Mask)	0 - 255 (Mask)
Status Information	1xx0 xxxx	0x10 0xxx	0 - 255
Version Number	1	no change	Factory-defined

x = actual value depend on the operation status

DALI Declaration for Factory Variables (for Part 206)

Variable	Default Value	Reset Value	Received Command	Range of Validity
Dimming Curve	0	No change	0	0-1; (2 - 255 reserved)
Converter Features	0111 0101	No change	0111 0101	Factory-defined
Failure Status	0000 0000	No change	0000 0000	0 - 255
Converter Status	0000 0000	No change	0000 0000	0 - 255
Extended Version Number	1	No change	1	Factory-defined
Device Type	5	No change	5	Factory-defined
Physical min Level	1	No change	1	1-253

Recommended LED Drivers, DALI-Bus Power Supplies and DALI Master

AC/DC LED Driver

RACD20-xxxD
RACD60-xxxxA
RACD45-xxxxA
RACD100-xxxxA
RACD150-xxxxA

DC/DC LED Driver

RCD24-xxx
RCD48-xxx
RBD12-xxx

DALI Master

tested with DALI-USB
Tridonic Osram*

*Software masterCONFIGURATOR V2.6.8.1005 Tridonic

Note:

For one DALI Converter (RELI-DA01/R) you can connect max. 6pcs of all series for RECOM AC/DC LED-Drivers with 3in1 dimming.

Typical Characteristics

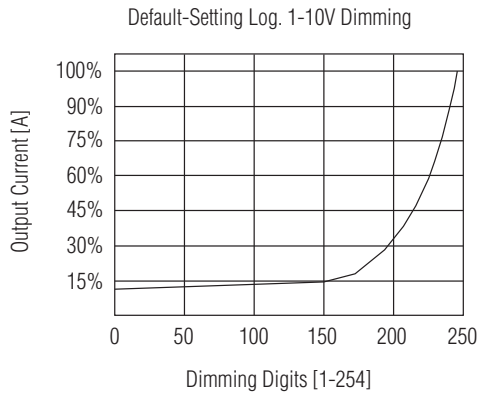

DALI-COMAND
Logarithmic Dimming; 1-10V
6 Recall MIN Level
272 ENABLE DEVICE TYPE X / Value: 5 dez
224 QUERY APP EXT Cmd224
257 DATA TRANSFER REGISTER (DTR) / Value: 0 dez
229 QUERY APP EXT Cmd229

Internal switch: OFF

DALI Connection

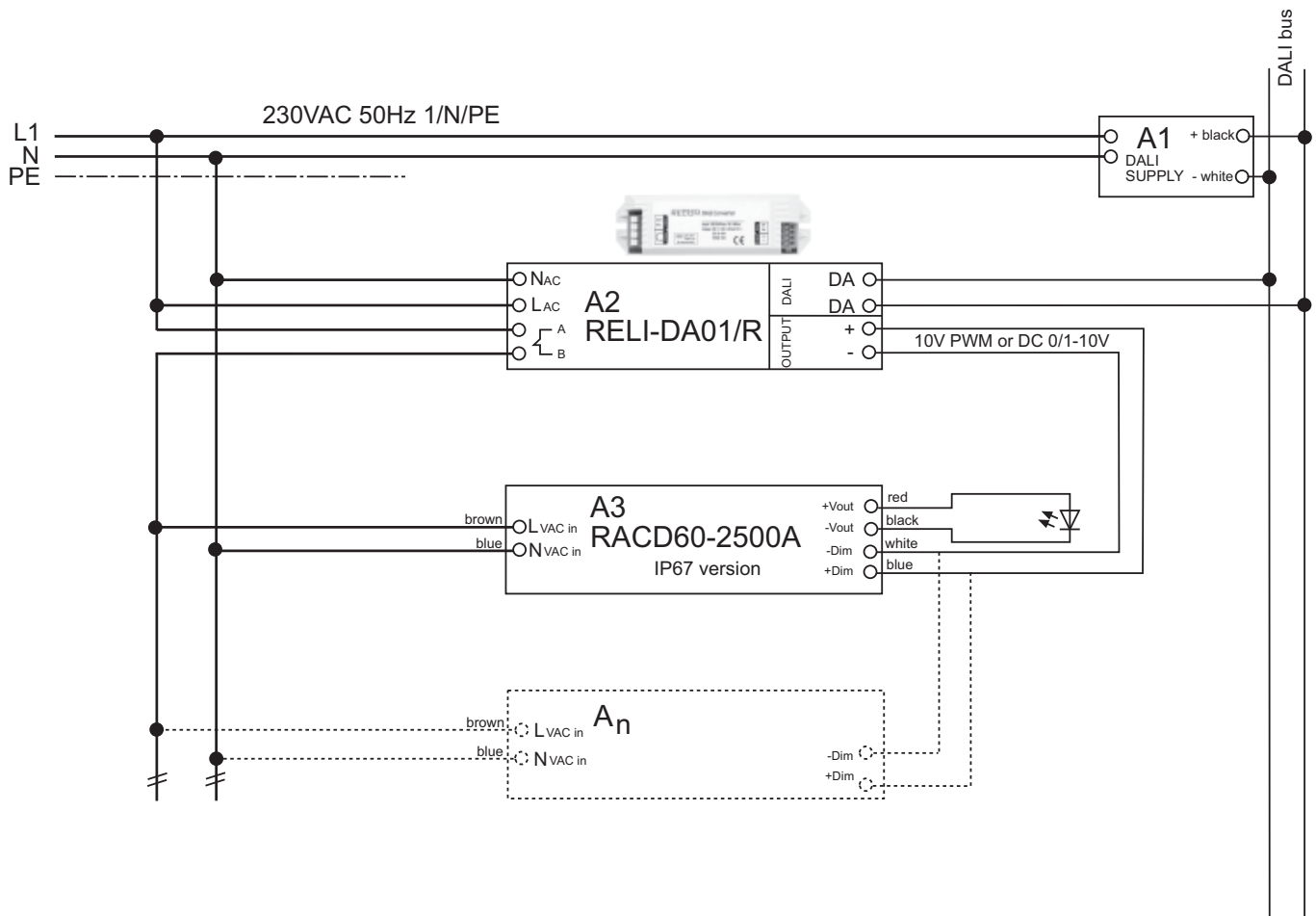

Package Style

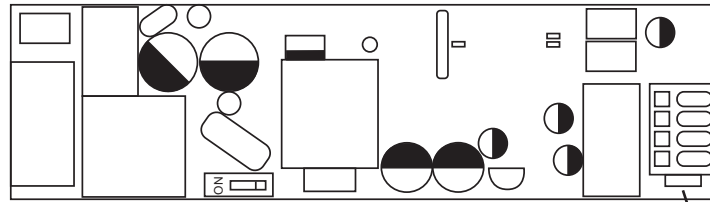

 ON / OFF
PWM / DC
By internal switch

Inductor LED
flashes with
DALI signal

ON: PWM 10V
OFF: DC 1-10V (Default DC)
DC 0-10V (By DALI Command-225*)

*DALI-Command-225
--> Query application-oriented extension commands

Delivery setting:
Output signal: DC 1-10V
Dimming curve: Logarithmic

Dimensions

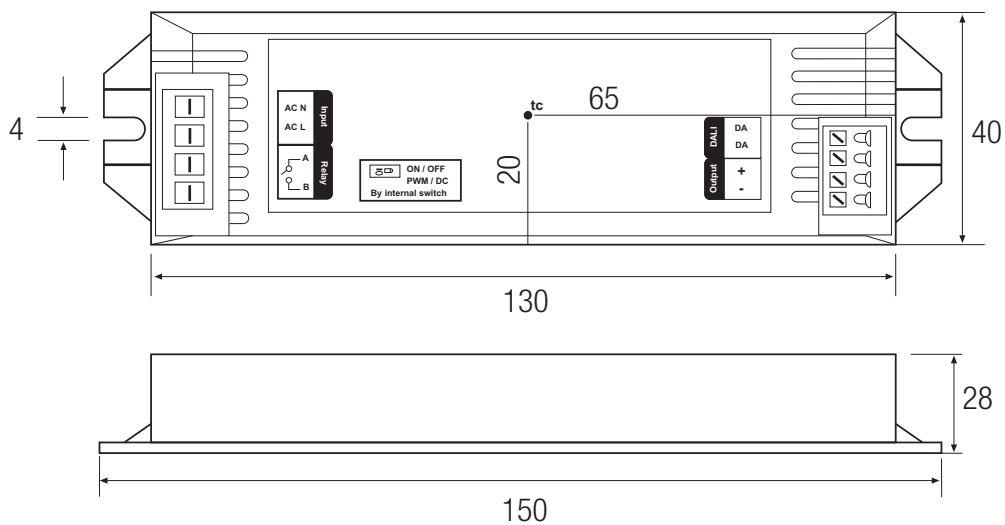

AC/DC LED DRIVERS

Symbols Used



CE Mark - RECOM declares that the product conforms to the European legislation on safety, health or environmental requirements. Not to be confused with the "China Export" mark which has no meaning.



RoHS 6/6- RECOM declares that the product conforms to the European legislation on the Restriction of Hazardous Substances (RoHS) and contains none of the six restricted chemicals.



UL, cUL- The product has been tested and certified by Underwriters Laboratories (UL) to meet US and Canadian safety standards. The UL file reference number is given under the symbol.



Lead-Free. The product contains no lead (<1000 ppm)



WEEE-Recycling Symbol. The product is electronic equipment that must be properly disposed of under the European Waste of Electrical and Electronic Equipment (WEEE) regulations.

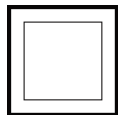

Double Isolated Class II Power Supply. No Earth connection required.

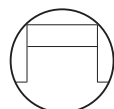

Independent Converter



Short Circuit Proof Isolating Safety Transformer

SELV

Safe Extra Low Voltage (SELV) outputs

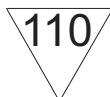

Maximum Case Temperature even in abnormal conditions



Product is safe to fit onto materials combustible above 200°C



Product is safe for use in furniture

POWERLINE AC/DC - CONTENTS



Single and Dual Output Models

Series	Isolation (kVAC)	Power (Watts)	Input Voltages (VAC)	Output Voltages (VDC)	Case Dimensions mm	Page
RAC01-RAC02-SC	3	1 or 2	90 - 264	3.3, 5, 9, 12, 15, 24	37.8 x 23.9 x 15.7	PA-2
RAC02-SC/277	3	2	80 - 305	3.3, 5, 12, 24	33.7 x 22.2 x 17.75	PA-4
RAC03-SC	3	3	90 - 264	3.3, 5, 9, 12, 15, 24	37.8 x 23.9 x 15.7	PA-6
RAC03-SC/277	3	3	80 - 305	3.3, 5, 12, 24	38.25 x 24.35 x 17.4	PA-8
RAC03-SCR/277	3	3	85 - 305	3.3, 5, 12, 24	50.3 x 50.3 x 11	PA-10
RAC04-SA_DA(-ST)	3	4	90 - 264	3.3, 5, 9, 12, 15, 24, 5/12	36.7 x 27.2 x 17.1	PA-12
RAC04-SA_DA(-ST)/277			90 - 305			
RAC04-C	3	4	80 - 264	3.3, 5, 9, 12, 15, 24	37.80 x 23.90 x 16.40	PA-14
RAC04-C/230	3.75	4	80 - 264	3.3, 5, 12, 15, 24, 5/12, ± 5 , ± 12	36.7 x 27.2 x 17.1	PA-16
RAC04-SC_DC/277	3.75	4	80-305	3.3, 5, 12, 15, 24, 5/12, ± 5 , ± 12	36.7 x 27.2 x 17.1	PA-19
RAC05-SA_DA(-E)(-ST)	3	5	90 - 264	3.3, 5, 12, 15, 24, ± 5 , ± 12 , ± 15	55.0 x 45.0 x 20.5	PA-22
RAC05-SB(-E)(-ST)	3	5	90 - 264	3.3, 5, 12, 15, 24	50.8 x 25.4 x 15.2	PA-24
RAC05-SC	3	5	80-264	3.3, 5, 12, 15, 24	50.9 x 25.5 x 15.65	PA-26
RAC05-DC				± 5 , ± 12 , ± 15	53.5 x 27.8 x 15.65	
RAC06-SC_DC(W)	3	6	80 - 264	3.3, 5, 12, 15, 24, ± 5 , ± 12 , ± 15	50.8 x 25.4 x 15.2	PA-29
RAC10-SA_DA(-E)(-ST)	3	10	90 - 264	3.3, 5, 12, 15, 24, ± 5 , ± 12 , ± 15	64.0 x 45.0 x 21.5	PA-31
RAC10-SB(-E)(-ST)	3	10	90 - 264	3.3, 5, 12, 15, 24	52.4 x 27.2 x 23.5	PA-33
RAC10-S_DC(/277)	3.75	10	80-305	3.3, 5, 12, 15, 24, ± 5 , ± 12 , ± 15	52.4 x 27.4 x 23.5	PA-35
RAC15-SA_DA(-E)(-ST)	3	15	90 - 264	5, 12, 15, 24, ± 5 , ± 12 , ± 15	74.0 x 54.0 x 22.0	PA-39
RAC20-SA_DA(-ST)	3	20	90 - 264	3.3, 5, 12, 15, 24, ± 5 , ± 12 , ± 15	70.0 x 48.0 x 22.0	PA-41
RAC20-SB(-ST)	3	20	90 - 264	3.3, 5, 12, 15, 24	52.4 x 27.2 x 23.5	PA-43
RAC30-SA_DA(-E)(-ST)	3	30	90 - 264	3.3, 5, 12, 15, 24, ± 5 , ± 12 , ± 15 , 5/12	89.0 x 63.5 x 25.0	PA-45
RAC40-SB_DB(-E)(-ST)	4	40	90 - 264	5, 12, 15, 24, ± 5 , ± 12 , ± 15 , 5/12	89.0 x 63.5 x 27.0	PA-47
RAC60-SB	4	60	85 - 264	5, 12, 15, 24	109.0 x 58.5 x 30.0	PA-49

AC/DC

Triple Output Models

Series	Isolation (kVAC)	Power (Watts)	Input Voltages (VAC)	Output Voltages (VDC)	Case Dimensions mm	Features	Page
RAC15-TA(-E)(-ST)	3	15	90 - 264	5 / ± 12 , 5 / ± 15	74.0 x 54.0 x 22.0	Standard	PA-39
RAC20-TA(-ST)	3	20	90 - 264	5 / ± 12 , 5 / ± 15	70.0 x 48.0 x 22.0	Standard	PA-41
RAC30-TA(-E)(-ST)	3	30	90 - 264	5 / ± 12 , 5 / ± 15	89.0 x 63.5 x 25.0	Standard	PA-45
RAC40-TB(-E)(-ST)	4	40	90 - 264	5 / ± 12 , 5 / ± 15	89.0 x 63.5 x 25.0	Standard	PA-47

Suffix -E = Extended Temperature range (-40°C)

Suffix -ST = Screw Terminal version (supplied with DIN Rail mounting bracket)

Features

Regulated Converters

- Ultracompact Low Profile AC-DC Power Supply
- Ultra-low 30mW Standby Power Consumption
- 1 Watt or 2 Watt PCB Mount Package
- Extra Wide Input Voltage Range (80~264VAC)
- Class II Power Supply with 3kVAC Isolation
- -25°C to +85°C Operating Temp
- Low Output Ripple
- Short Circuit Protected Outputs
- EN, UL and CE Certified

Description

The RAC01-SC and RAC02-SC series are ultra-compact universal input AC/DC power modules for PCB mounting. They feature high efficiency, low standby power, high operating temperature, soft start and short-circuit protection as well as a built-in EMC Class B filter. Output voltages range from 3.3VDC to 24VDC.

Selection Guide

Part Number	Input Range (VAC)	Output Voltage (VDC)	Output Current (mA)	Efficiency typ. (%)	Max Capacitive Load ⁽¹⁺²⁾
RAC01-3.3SC	80-264	3.3	300	65	2200µF
RAC02-3.3SC			600	66	2700µF
RAC01-05SC	80-264	5	200	68	1600µF
RAC02-05SC			400	70	2000µF
RAC01-09SC	80-264	9	111	70	470µF
RAC02-09SC			222	72	560µF
RAC01-12SC	80-264	12	83	72	180µF
RAC02-12SC			167	74	200µF
RAC01-15SC	80-264	15	67	72	180µF
RAC02-15SC			133	74	200µF
RAC01-24SC	80-264	24	42	73	68µF
RAC02-24SC			83	77	68µF

Specifications (measured at TA 25°C, full load after warm-up)

Input Voltage Range (with derating)	80-264VAC or 115-370VDC	
Rated Power	1 or 2 Watts max.	
Input Frequency Range (for AC Input)	47-63Hz	
Input Current (full load)	RAC01 (115/230VAC)	34mA/23mA max.
	RAC02 (115/230VAC)	55mA/36mA max.
No Load Power Consumption	@115VAC	30mW typ.
	@230VAC	80mW typ.
Inrush Current (<0.5ms)	30/60A max.	
Leakage Current	0.25mA max.	
Output Voltage Tolerance (combined Tolerance, Line Reg and Load Reg at full load)	±5% max.	
Line Voltage Regulation	low line, high line at full load	±2% max.
Load Voltage Regulation	10% to 100% full load	±6% max.
Output Ripple (20MHz BW limited)	3.3V Output	<150mVrms
	All others	<100mVrms
Operating Frequency (full load)	30kHz typ.	
Minimum Load = 0%	specifications valid for 10% minimum load only	
RMS Isolation Voltage (input to output)	3kVAC / 1 minute	
Isolation Resistance	1 GΩ min.	
Short Circuit Protection	Hiccup, Automatic Restart	
Operating Temperature Range	(1W, natural convection, no derating)	-25°C to +80°C
	(2W natural convection, no derating)	-25°C to +75°C
	(natural convection, with derating)	-25°C to +85°C
Storage Temperature Range	-40°C to +100°C	
Humidity	non-condensing	95% RH max
Case Material	Plastic Case, Silicone potting material (UL94V-0)	

continued on next page

POWERLINE

AC/DC-Converter

with 3 year Warranty

RECOM

1 - 2 Watt Single Output



EN-60950-1 Certified
UL-60950-1 Certified

RAC01-C

RAC02-C

Derating Graph (Ambient Temperature)

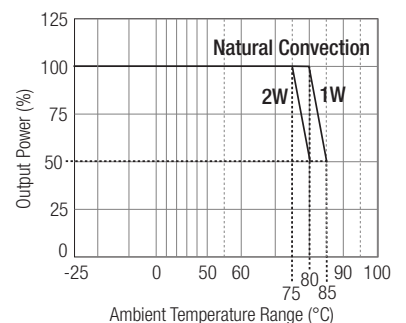

Refer to Application Notes

POWERLINE

AC/DC-Converter

RAC01-SC

RAC02-SC

Specifications (measured at TA 25°C, full load after warm-up)

Package Weight		25g
Packing Quantity		22 pcs
EMC	Conducted and Radiate	EN55022 Class B
	Noise Immunity	EN55024
MTBF	+25°C	666 x 10 ³ hours
230VAC	+55°C	395 x 10 ³ hours
using MIL-HDBK-217F	+80°C	125 x 10 ³ hours
Certifications:		
UL General Safety	File Nr. E224736	UL-60950-1, 2nd Edition
EN General Safety	SPCLVD 1202026	EN-60950-1, 2nd Edition
CE	Report: 2011-04-19	EN55022 Class B

Notes:

Note1: Measured @ 230VAC / 50Hz / Ta=25°C with constant resistant mode at full load.

Note2: If used @ 115VAC / 60Hz with full load, max. capacitive load is less, please contact RECOM for detailed information.

RAC01-05SC

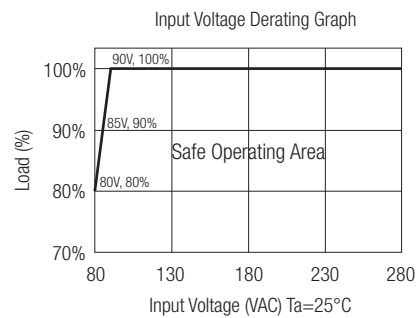
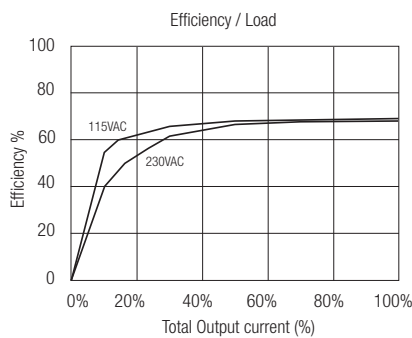

Standard Package Style and Pinning

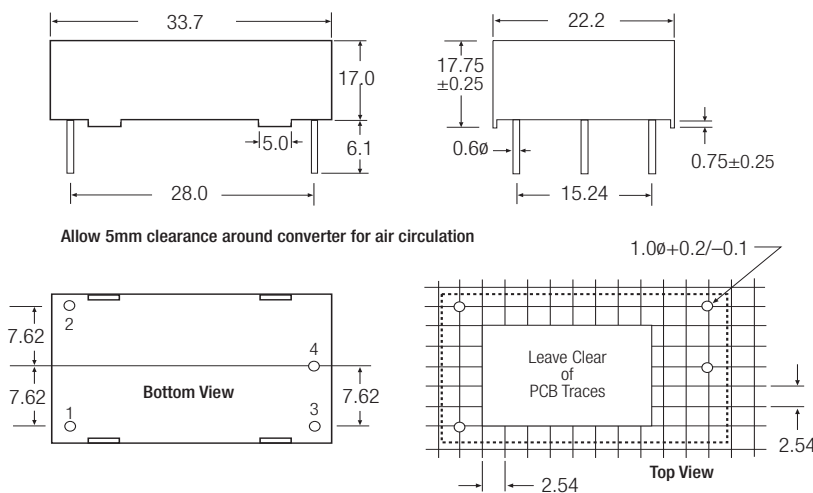

Pin Connections

Pin #	Single Output
1	VAC in (N)
2	VAC in (L)
3	-VDC out
4	+VDC out

Tolerance ± 0.5 mm unless otherwise specified

Recommended Application Circuit

Compact single output regulated power supply

Suggested fuse rating: 1A Slow Blow.

An external MOV is required for 230VAC operation. The varistor should comply with IEC-61051-2 e.g. Epcos S14 series

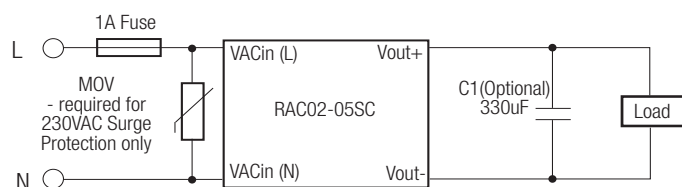

Add C1 to reduce output ripple (use low ESR type)

The product information and specifications are subject to change without prior notice. All products are designed for non-safety critical commercial and industrial applications. The Buyer agrees to implement safeguards that anticipate the consequences of any failures that might cause harm, loss of life and/or damage property.

Features

Regulated Converters

- 35mW max of No Load Power Consumption
- Output CV/CC Control
- Isolated Output 3kVAC / 1 min
- Short Circuit Protection
- Overvoltage Protection
- Meet EN55022 and FCC Class B
- Built-In Fusible Resistor

Selection Guide

Part Number	Output Voltage (VDC)	Max. Current (Io, max)	Total Regulation ⁽³⁾	Ripple & Noise ⁽⁴⁾	Efficiency (Typ.)	Max. Capacitive Load ⁽¹⁺²⁾
RAC02-3.3SC/277	3.3	600mA	±6%	300mV	67%	24000µF
RAC02-05SC/277	5	400mA	±6%	200mV	71%	7500µF
RAC02-12SC/277	12	167mA	±6%	200mV	74%	1200µF
RAC02-24SC/277	24	83mA	±6%	200mV	76%	200µF

Specifications (measured at TA 25°C, full load after warm-up)

Input Voltage Range (with Derating)	80-305VAC or 110-430VDC	
Input Frequency	47-440Hz	
Input Current (full load)	115VAC/230VAC	47mA / 30mA typ.
Inrush Current	115VAC/230VAC	15A / 30A max.
No Load Power Consumption	80-305VAC	35mW max.
Output Voltage (Vout nom.)	3.3V-24V	
Output Voltage Tolerance	±6% max.	
Minimum Load	2%	
Line Voltage Regulation	LL-HL at full Load	±1.5% max.
Load Voltage Regulation	2-100% Load	see Selection Guide
Switching Frequency	at full Load	45kHz typ.
Isolation Voltage	Input-Output	3kVAC / 1 minute
Leakage Current	80-305VAC	10uA max.
Isolation Resistance	1GΩ min	
Short Circuit Protection	Continuous, Auto Restart	
Over-Voltage Protection	Zener clamp, set at 4.4~5.0V for 3.3V and 110~140% of its nominal output voltage for others.	
Operating Temperature Range	natural convection, without derating	-25°C to +75°C
	natural air convection, with derating	-25°C to +85°C
	Case Temperature	90°C max
Storage Temperature Range	-40°C to +85°C	
Case Material	UL94V-0 black plastic	
Potting Material	Silicon	
Relative Humidity	95% RH max.	
Package Weight	24.5g typ.	
Package Quantity	22 pcs	
MTBF (using MIL-HDBK217F)	TA = 25°C	> 1300x10 ³ hours
	TA = 75°C	> 165x10 ³ hours
Physical	Dimension (LxWxH)	33.7 x 22.2 x 17.75 mm
EMI	EN55022, Class B	
Safety Standard		
IEC/EN General Safety	Report: SPCLVD1208051	IEC/EN-60950-1
UL General Safety	Report: E224736-A17-UL	UL-60950-1

continued on next page

POWERLINE

AC/DC-Converter

with 3 year Warranty

RECOM

2 Watt Single Output

eFUS
E224736



EN-60950-1 Certified
UL-60950-1 Certified

RAC02-SC/277

Derating Graph (Ambient Temperature)

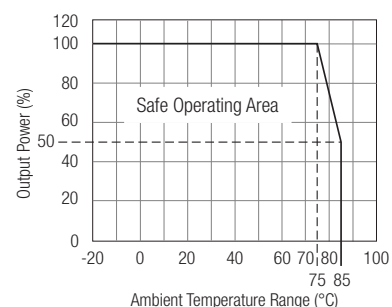

Refer to Application Notes

Specifications (measured at TA 25°C, full load after warm-up)

Notes:

Note1: Measured @ 230VAC / 50Hz / Ta=25°C with constant resistant mode at full load.

Note2: If used @ 115VAC / 60Hz with full load, max. capacitive load is less, please contact RECOM for detailed information

Note3: „Total Regulation“ is the output voltage tolerance which includes initial voltage accuracy, thermal drift, lineregulation and load regulation at rated input voltage and load condition.

Note4: „Ripple & Noise“ is maximum peak-to-peak voltage value measured at output within 20MHz bandwidth at rated line voltage and output load ranges, and with a 47 µF low-ESR electrolytic capacitor in parallel with a 0.1 µF ceramic capacitor across the output.

Specifications (measured at TA 25°C, full load after warm-up)

Output V-I Characteristic

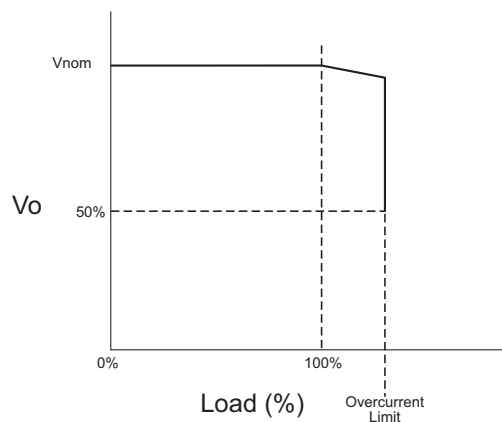

Input Voltage Derating Graph

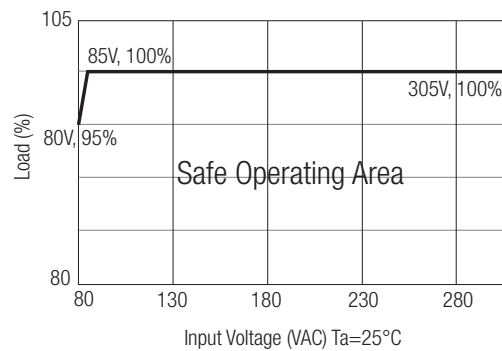

Package Style and Pinning

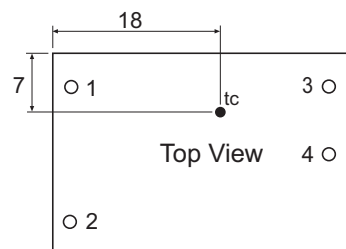
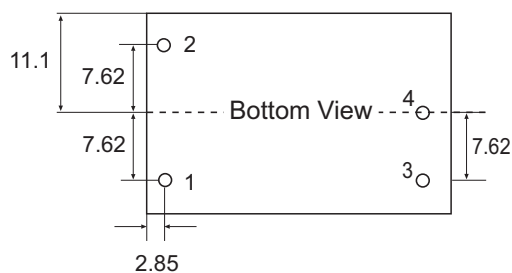
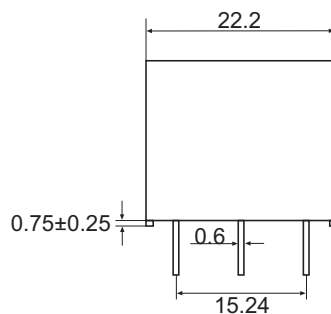
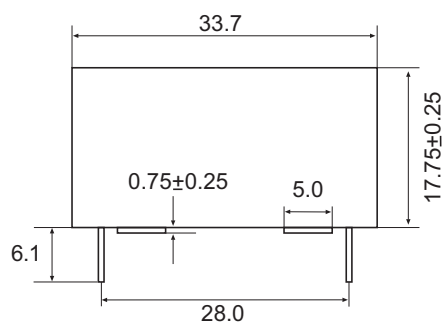

Pin Connections

Pin #	Single Out
1	VAC in (N)
2	VAC in (L)
3	-VDC out
4	+VDC out

Tolerance ±0.5mm unless otherwise specified

The product information and specifications are subject to change without prior notice. All products are designed for non-safety critical commercial and industrial applications. The Buyer agrees to implement safeguards that anticipate the consequences of any failures that might cause harm, loss of life and/or damage property.

Features

Regulated Converters

- Ultracompact Low Profile AC-DC Power Supply
- 3 Watt PCB Mount Package
- Universal Input Voltage Range
- Class II Power Supply with 3kVAC Isolation
- Only 80mW Consumption in Standby
- -25°C to +85°C Operating Temperature
- Low Output Ripple/Noise
- Short Circuit Protected Outputs
- EN, UL and CE Certified

Description

The RAC03-SC series is an ultra-compact universal input AC/DC power module for PCB mounting. It features high efficiency, low standby power, high operating temperature, soft start, low output ripple/noise, overload and short-circuit protection as well as a built-in EMC Class B filter. Output voltages range from 3.3VDC to 24VDC, including a 3.8VDC version designed for battery chargers and GSM modems.

Selection Guide

Part Number	Input Range (VAC)	Output Voltage (VDC)	Output Current (mA)	Efficiency (%)	Max Capacitive Load ⁽¹⁺²⁾
RAC03-3.3SC	80-264	3.3	900	67	6800µF
RAC03-3.8SC	80-264	3.8	900	67	6800µF
RAC03-05SC	80-264	5	600	72	4000µF
RAC03-09SC	80-264	9	333	76	3000µF
RAC03-12SC	80-264	12	250	76	680µF
RAC03-15SC	80-264	15	200	76	470µF
RAC03-24SC	80-264	24	125	78	200µF

Specifications (measured at TA 25°C, full load after warm-up)

Input Voltage Range (with derating)	80-264VAC or 115-370VDC	
Rated Power	3 Watts max.	
Input Frequency Range (for AC Input)	47-63Hz	
Input Current (full load)	115/230VAC	85mA/40mA max.
No Load Power Consumption	80mW typ.	
Inrush Current (<0.5ms)	115/230VAC	30/60A max.
Leakage Current	0.85mA max.	
Output Voltage Tolerance (combined Tolerance, Line Reg and Load Reg at full load)	±5% max.	
Line Voltage Regulation	low line, high line at full load	±3% max.
Load Voltage Regulation	10% to 100% full load	±6% max.
Output Ripple and Noise (20MHz BW limited)	3.3V, 3.8V, 5V Output	120mVp-p max.
	All others	150mVp-p max.
Operating Frequency @ full load	35kHz typ	
Hold-up Time	115 VAC	15ms typ.
	230VAC	80ms typ.
Minimum Load = 0%	specifications valid for 10% minimum load only	
RMS Isolation Voltage	input to output	3kVAC / 1 minute
Isolation Resistance	input to output	1 GΩ min.
Isolation Capacitance	input to output	1000pF typ.
Short Circuit Protection	Hiccup, Automatic Restart	
Operating Temperature Range	(natural convection, without derating)	-25°C to +75°C
	(natural convection, with derating)	-25°C to +85°C
Storage Temperature Range	-40°C to +100°C	
Humidity	non-condensing	95% RH max
Case Material	Plastic Case, Silicon filled (UL94V-0)	
Package Weight	30g	
Packing Quantity	12 pcs	
EMC	Conducted and Radiated	EN 55022 Class B
	Noise Immunity	EN 55024

continued on next page

POWERLINE

AC/DC-Converter

with 3 year Warranty

RECOM

3 Watt Single Output



E224736



EN-60950-1 Certified
UL-60950-1 Certified

RAC03-SC

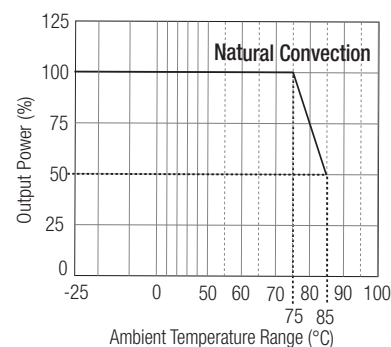
Derating Graph (Ambient Temperature)



Refer to Application Notes

Specifications (measured at TA 25°C, full load after warm-up)

MTBF	+25°C	>550 x 10 ³ hours
230VAC	+55°C	>285 x 10 ³ hours
using MIL-HDBK-217F	+80°C	>76 x 10 ³ hours
Certifications:		
UL General Safety	File Nr. E224736	UL-60950-1, 2nd Edition
EN General Safety	SPCLVD 1202026	EN-60950-1, 2nd Edition
CE	Report: T110809202-E	EN55022 Class B

Notes:

Note1: Measured @ 230VAC / 50Hz / Ta=25°C with constant resistant mode at full load.

Note2: If used @ 115VAC / 60Hz with full load, max. capacitive load is less, please contact RECOM for detailed information.

RAC03-05SC

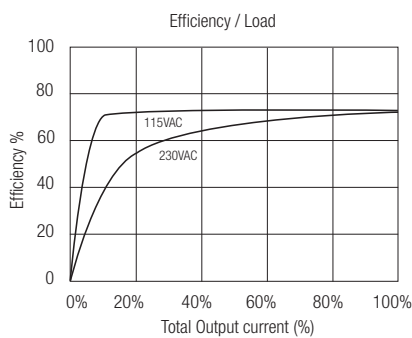

Input Voltage Derating Graph

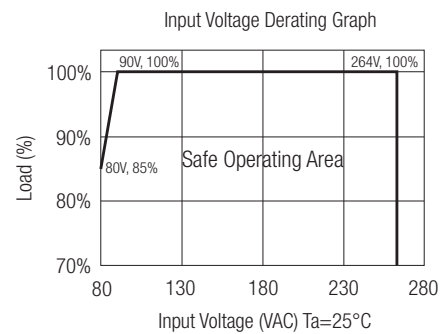

Standard Package Style and Pinning

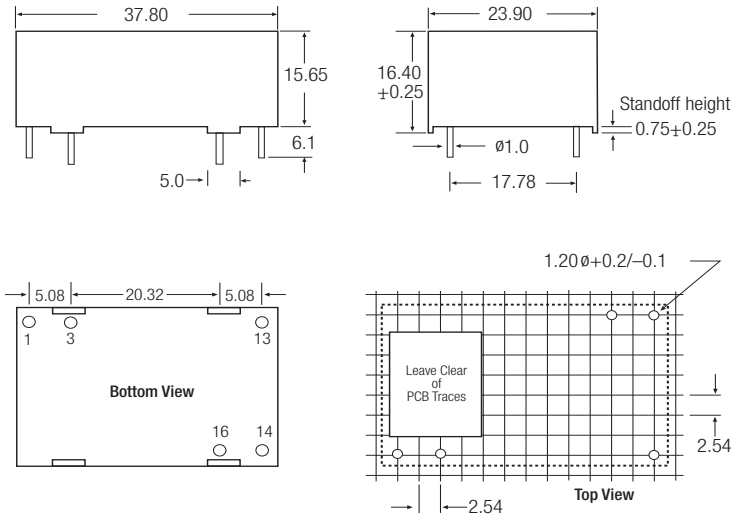

Pin Connections

Pin #	Single Output
1	VAC in (L)
3	VAC in (N)
13	NC
14	-VDC out
16	+VDC out

NC = No Connection

Tolerance ± 0.5 mm unless otherwise specified

Recommended Application Circuit

Compact single output regulated power supply

Suggested fuse rating: 1A Slow Blow

An external MOV is required for 230VAC operation. The varistor should comply with IEC-61051-2. e.g. Epcos S14 Series

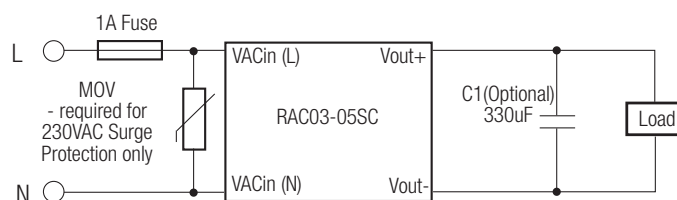

Add C1 to reduce output ripple (use low ESR type)

The product information and specifications are subject to change without prior notice. All products are designed for non-safety critical commercial and industrial applications. The Buyer agrees to implement safeguards that anticipate the consequences of any failures that might cause harm, loss of life and/or damage property.

Features

Regulated Converters

- 30mW max of No Load Power Consumption
- High efficiency up to 80%
- Isolated Output 3kVAC / 1 min
- Short Circuit Protection
- Overvoltage Protection
- Meet EN55022 and FCC Class B
- Built-In Fusible Resistor

Selection Guide

Part Number	Output Voltage (VDC)	Max. Current (Io, max)	Total Regulation ⁽³⁾	Ripple & Noise ⁽⁴⁾	Efficiency (Typ.)	Max. Capacitive Load ⁽¹⁺²⁾
RAC03-3.3SC/277	3.3	900mA	±6%	200mV	71%	47000µF
RAC03-05SC/277	5	600mA	±6%	150mV	76%	15000µF
RAC03-12SC/277	12	250mA	±6%	150mV	78%	2200µF
RAC03-24SC/277	24	125mA	±6%	150mV	80%	390µF

Specifications (measured at TA 25°C, full load after warm-up)

Input Voltage Range (with Derating)	80-305VAC or 110-430VDC	
Input Frequency	47-440Hz	
Input Current (full Load)	115VAC/230VAC	70mA / 45mA typ.
Inrush Current	115VAC/230VAC	15A/30A max.
No Load Power Consumption	80-305VAC / 47-440Hz 30mW max.	
Output Voltage (Vout nom.)	3.3V-24V	
Output Voltage Tolerance	±6% max.	
Minimum Load	2%	
Line Voltage Regulation	LL-HL at full Load	±1% typ. / ±1.5% max.
Load Voltage Regulation	2-100% Load	see Selection Guide
Hold-up Time	115VAC	15ms typ.
	230VAC	80ms typ.
Overcurrent Limit	116% - 156%	
Switching Frequency	at full Load	45kHz typ.
Isolation Voltage	Input-Output	3kVAC / 1 minute
Leakage Current	80-305VAC / 47-440Hz 10µA max.	
Isolation Resistance	1G Ω min	
Short Circuit Protection	Continuous, Auto Restart	
Over-Voltage Protection	Zener clamp, set at 4.4V-5.0V for 3.3V and others	
	112-140% of its nominal output voltage	
Operating Temperature	natural convection, without derating	-25°C to +75°C
	natural air convection, with derating	-25°C to +85°C
Storage Temperature	-40°C to +85°C	
Case Material	UL94V-0 black plastic	
Potting Material	Silicon	
Relative Humidity	95% RH max.	
Package Weight	28g	
Package Quantity	12 pcs	
MTBF (using MIL-HDBK217F)	TA = 25°C	> 1000x10 ³ hours
	TA = 75°C	> 100x10 ³ hours
Physical	Dimension (LxWxH)	38.25 x 24.35 x 17.40 mm
EMI	EN55022, Class B	
Safety Standard		
EC/EN General Safety	Report: SPCLVD1208051	IEC/EN-60950-1
UL General Safety	Report: E224736-A17-UL	UL-60950-1

continued on next page

POWERLINE

AC/DC-Converter
with 3 year Warranty

RECOM

3 Watt Single Output



EN-60950-1 Certified
UL-60950-1 Certified

RAC03-SC/277

Derating Graph (Ambient Temperature)

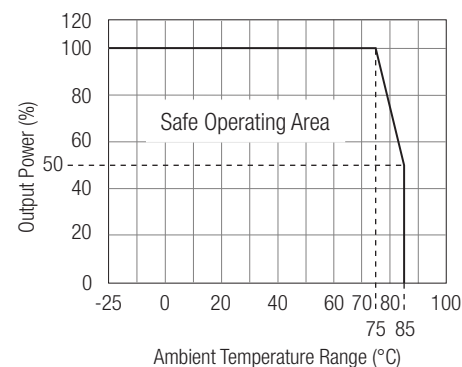

Refer to Application Notes

RAC03-xxSC/277

Series

POWERLINE

AC/DC-Converter

Specifications (measured at TA 25°C, full load after warm-up)

Notes:

Note1: Measured @ 230VAC / 50Hz / Ta=25°C with constant resistant mode at full load.

Note2: If used @ 115VAC / 60Hz with full load, max. capacitive load is less, please contact RECOM for detailed information.

Note3: „Total Regulation“ is the output voltage tolerance which includes initial voltage precise, thermal drift, line regulation and load regulation at rated input voltage and load condition.

Note4: „Ripple & Noise“ is maximum peak-to-peak voltage value measured at output within 20MHz bandwidth at rated line voltage and output load ranges, and with a 47 µF low-ESR electrolytic capacitor in parallel with a 0.1 µF ceramic capacitor across the output.

Output V-I Characteristic

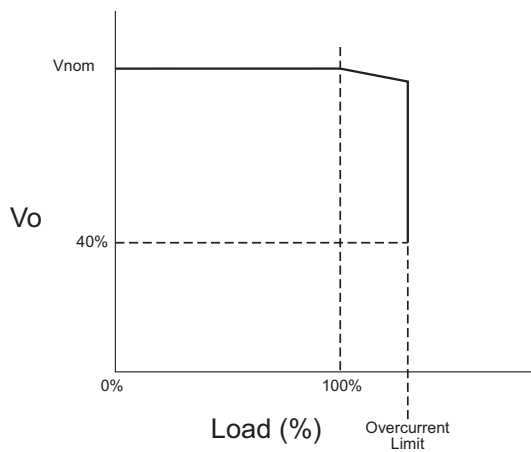

Input Voltage Derating Graph

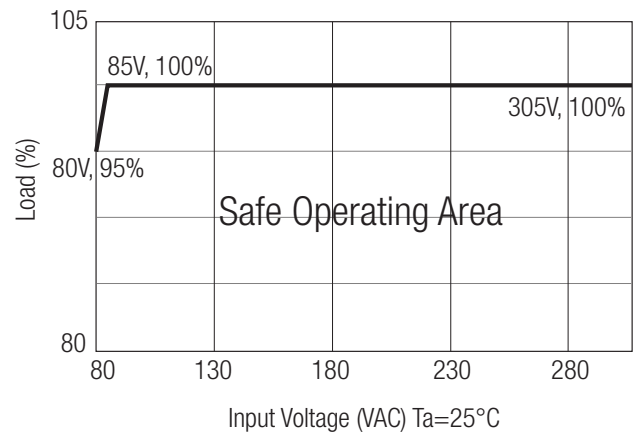

Package Style and Pinning

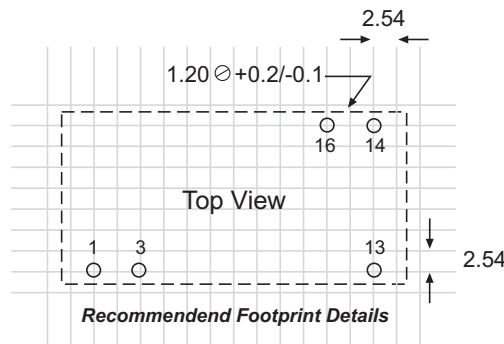
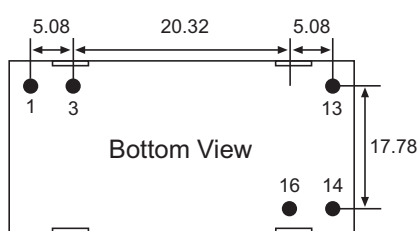
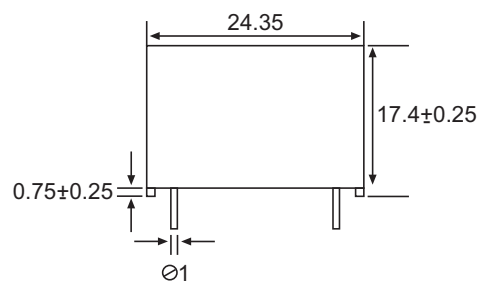
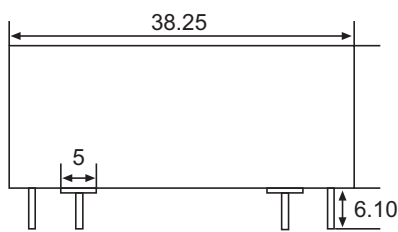

Pin Connections

Pin #	Single Out
1	VAC in (L)
3	VAC in (N)
13	NC
14	-VDC out
16	+VDC out

Tolerance $\pm 0.5\text{mm}$ unless otherwise specified

The product information and specifications are subject to change without prior notice. All products are designed for non-safety critical commercial and industrial applications. The Buyer agrees to implement safeguards that anticipate the consequences of any failures that might cause harm, loss of life and/or damage property.

Features

Regulated Converters

- Universal Input 85-305VAC
- Regulated Power Supply
- Continuous Short Circuit Protection
- Isolated Output 3kVAC / 1 min
- Meet EN55022 and FCC Class B
- Ultra-low Stand-By Power Consumption

Selection Guide

Part Number	Input Range (VAC)	Output Voltage (VDC)	Output Current (mA)	Typical Efficiency (%)	Max. Capacitive Load ⁽¹⁺²⁾
RAC03-3.3SCR/277*	85-305	3.3	900	68	22000
RAC03-05SCR/277*	85-305	5	600	70	10000
RAC03-12SCR/277*	85-305	12	250	74	1500
RAC03-24SCR/277*	85-305	24	125	76	200

* add „-Tray“ for Tray packaging, e.g. RAC03-05SCR/277-Tray

Specifications (measured at TA 25°C, full load after warm-up)

Input Voltage Range	85-305VAC or 120-430VDC	
Rated Power	3 Watts	
Input Frequency Range (for AC Input)	47-440Hz	
Input Current (Full Load)	115VAC / 230VAC	70mA / 45mA typ.
No Load Power Consumption	85-305VAC / 47-440Hz	75mW max.
Inrush Current (<2ms)	115VAC	15A max.
	230VAC	30A max.
Output Voltage	3.3V-24V	
Output Voltage Tolerance ⁽³⁾	3.3V	±4% typ. / ±8% max.
	5V	±3.5% typ. / ±5% max.
	12V / 24V	±3% typ. / ±4% max.
Output Current	see Selection Guide	
Output Ripple & Noise ⁽⁴⁾	3.3V	250mVp-p
	5V	200mVp-p
	12V / 24V	150mVp-p
Switching Frequency	@ Full Load	45kHz typ.
Hold-up Time	115VAC	18ms min.
Minimum Load	10%	
Line Voltage Regulation	LL-HL @ Full Load	±0.7% typ. / ±1% max.
Load Regulation (10%-100% Load)	3.3V	±5.5% typ. / ±9% max.
	5V	±5% typ. / ±7.5% max.
	12V, 24V	±4% typ. / ±5.5% max.
Leakage Current	85-305VAC / 47-440Hz	10uA max.
Isolation Voltage	3kVAC / 1minute	
Isolation Resistance	1GΩ min	
Short Circuit Protection	Continuous, Auto Restart	
Over Current Limit	105% - 150%	
Over Voltage Protection (Zener diode clamp)	130%-160%	
Operating Temperature Range	natural convection, without derating	-25°C to +75°C
	natural air convection, with derating	-25°C to +85°C
Storage Temperature Range	-40°C to +85°C	
Relative Humidity	95% RH max.	
Case Material	UL94V-0 Black Plastic	
Potting Material	Epoxy	

continued on next page

POWERLINE

AC/DC-Converter

with 3 year Warranty

RECOM

3 Watt Single Output



CE Marked
UL-60590-1 Certified

RAC03-SCR/277

Derating Graph

(Ambient Temperature)

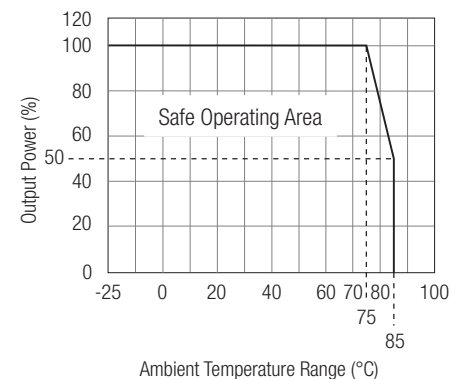

Refer to Application Notes

Specifications (measured at TA 25°C, full load after warm-up)

Package Weight			41g typ.
Package Quantity			12pcs
	„-Tray“-Version		72pcs
Physical Dimension (LxWxH)			50.3 x 50.3 x 11.0mm
RoHS			Test Report: KA/2012/91224
EMC			EN55022 Class B
Certifications			
UL General Safety	File Number: E224736	UL-60950-1	
EN General Safety	Report: TI20925N01-E	EN-55022: 2010 Class B, EN-55024:2010	
MTBF	TA = 25°	1300 x 10 ³ hours	
(using MIL-HDBK-217F)	TA = 75°	160 x 10 ³ hours	

Notes:

Note1: Measured @ 230VAC / 50Hz / Ta=25°C with constant resistant mode at full load.

Note2: If used @ 115VAC / 60Hz with full load, max. capacitive load is less, please contace RECOM for detailed information.

Note3: The “output voltage tolerance” includes initial voltage accuracy, thermal drift, line regulation and load regulation at rated input voltage and load conditions.

Note4: “Ripple and Noise” is the maximum peak-to-peak voltage value measured at the output with a 20 MHz bandwidth, at rated line voltage at full load.

Ambient Temperature vs. Input Voltage

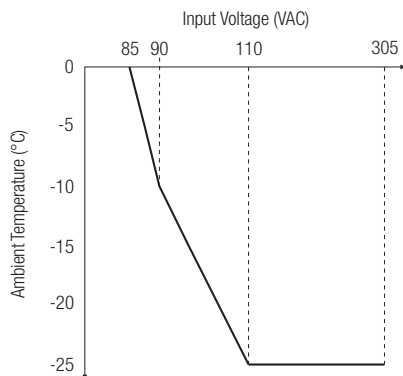

Efficiency vs. Load

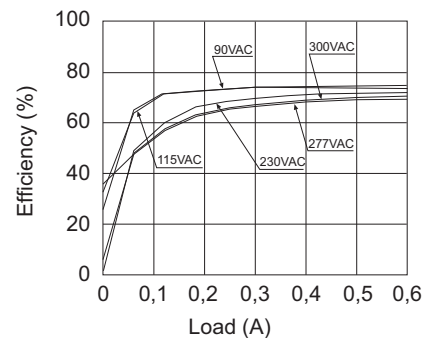

Mechanical Dimension

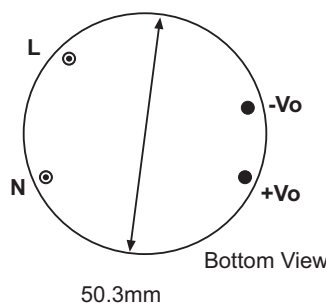
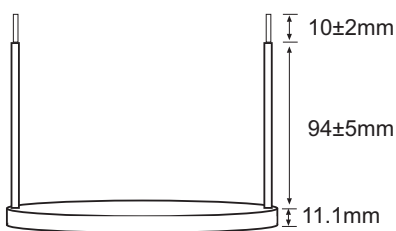

Wire Connections

Wire #	Color	AWG#	Length	Terminal
1	Brown	AWG#22	1015	VAC in (L)
2	Blue	AWG#22	1015	VAC in (N)
3	Red	AWG#22	1430	+VDC out
4	Black	AWG#22	1430	-VDC out

Tolerance ±0.5mm unless otherwise specified

The product information and specifications are subject to change without prior notice. All products are designed for non-safety critical commercial and industrial applications. The Buyer agrees to implement safeguards that anticipate the consequences of any failures that might cause harm, loss of life and/or damage property.

Features

Regulated Converters

- Ultracompact AC-DC Power Supply
- 4 Watt PCB Mount Package
- Universal Input Voltage Range including 277VAC
- 3kVAC Isolation (Class II)
- Very Low No Load Input Current
- Dual output version for standby relay circuits
- Short Circuit Protected
- EN/UL Certified, CE Marked.

Description

The RAC04 series is an ultra-compact universal input AC/DC power module for PCB mounting. It features ultralow no-load power consumption, short circuit, overload and output overvoltage protection as well as a built-in EMC Class B filter. A high input voltage version (suffix /277) is also available for input voltages of up to 305VAC or 430VDC.

Selection Guide

Part Number	Input Range (VAC)* (Std)	Input Range (VAC)* (/277)	Output Voltage (VDC)	Output Current (mA)	Efficiency (%)	Max Capacitive Load
RAC04-3.3SA	90-264	90-305	3.3	1200	68	14000µF
RAC04-05SA	90-264	90-305	5	800	72	8000µF
RAC04-09SA	90-264	90-305	9	444	75	2400µF
RAC04-12SA	90-264	90-305	12	333	76	1000µF
RAC04-15SA	90-264	90-305	15	267	76	700µF
RAC04-24SA	90-264	90-305	24	167	77	220µF
RAC04-0512DA	90-264	90-305	5/12	120/250	75	4700/330µF

* add suffix /277 for 90-305VAC input. High input voltage converters are identified by omitting pin 1.

Specifications (typical at 25°C and after warm up time unless otherwise specified)

Input Voltage Range	standard	90-264VAC or 120-370VDC
	/277 versions	90-305VAC or 120-430VDC
Rated Power		4 Watts max
Input Frequency Range (for AC Input)		47-440Hz
Input Current (full load)	115/230VAC	95/65mA max.
	/277	75/55mA max.
No Load Power Consumption	115/230/277VAC	150/210/220mW typ.
Inrush Current (<0.5ms)	115/230VAC	15/25A max.
Leakage Current		0.25mA max
Output Voltage Accuracy (full load)	single outputs	±2%
	3.3V (/277 Version)	±0.5%
Dual output version	5V/12V	±5%/±2%
Line Voltage Regulation (low line, high line at full load)		±0.2% typ
Dual output version	5V/12V	±3%/±0.2% typ
Load Voltage Regulation	3.3V output	±1% typ (
0% to 100% full load)	All others	±0.5% typ
Dual output version	5V/12V	±5%/±0.5% typ
Output Ripple and Noise	3.3V output	<250mVp-p max
(measured @ 20MHz of bandwidth with 0.1µF & 47µF parallel capacitor)	5V output	<200mVp-p max.
	All others	100mVp-p max
Operating Frequency		132kHz typ
Hold-up time		15ms min.
Minimum Load	single outputs	0%
	5V/12V	25%
RMS Isolation Voltage (input to output)		3KVAC / 1minute
Temperature Coefficient		±0.02%/°C typ
Isolation Resistance		100 MΩ max
Short Circuit Protection		Hiccup, Automatic Restart
Output Overvoltage Protection		Zener Clamping Diode
Operating Temperature Range	All others	-40°C to +70°C
(natural convection, with derating)	Dual output version	-40°C to +70°C
Storage Temperature Range		-40°C to +85°C
Humidity		95% RH max

continued on next page

POWERLINE

AC/DC-Converter

with 3 year Warranty

RECOM

4 Watt Single/Dual Output



E196683

EN 55022/55024 Certified

UL-60950-1 Certified

RAC04-A

Derating Graph (Ambient Temperature)

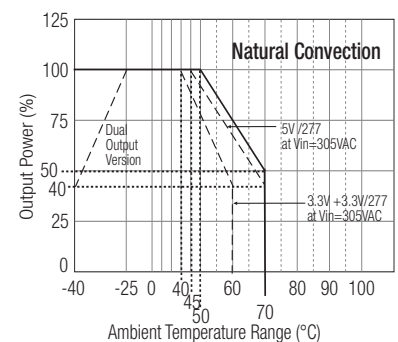

Refer to Application Notes

POWERLINE

AC/DC-Converter

RAC04-5A Series

Specifications (typical at 25°C and after warm up time unless otherwise specified)

Case Material	Epoxy with Fibreglass (UL94V-0)		
Package Weight	26g		
Packing Quantity	12 pcs		
EMC	Conducted and Radiated Noise Immunity	EN 55022 Class B EN 55024	
MTBF (+25°C)	using MIL-HDBK-217F	>350 x 10 ³ hours	

Typical Characteristics

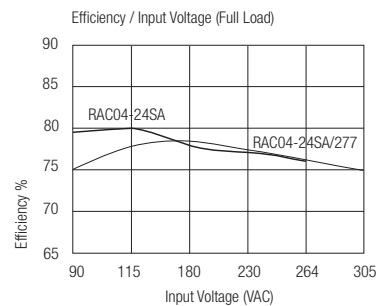
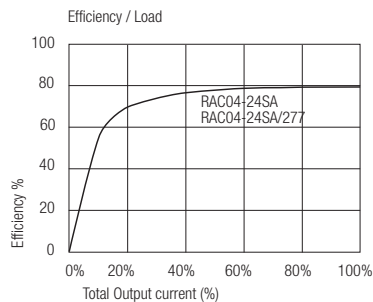

Standard Package Style and Pinning

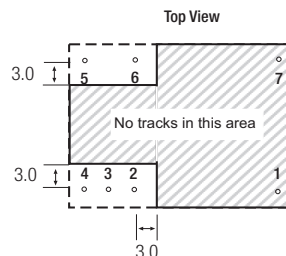
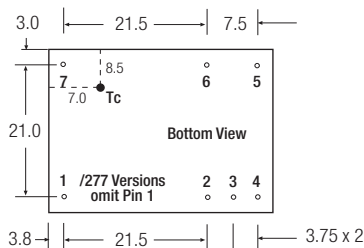
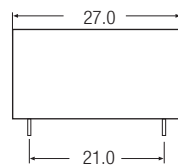
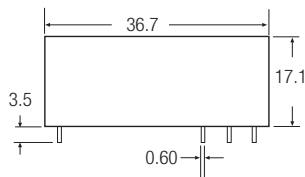

Pin Connections

Pin #	Single Output	Dual Output	/277 Versions
1	NC	NC	No Pin
2	+VDC out	+12V	same
3	-VDC out	Com	same
4	NC	+5V	same
5	VAC in (L)	VAC in (L)	VAC in (L)
6	VAC in (N)	VAC in (N)	VAC in (N)
7	NC	NC	NC

NC = No Connection

XX.X ± 0.5 mm
XX.XX ± 0.25 mm

It is recommended to additionally bond the /277 version of the converter to the PCB if the application is subject to vibration or mechanical shock.

Standard Application Circuit

Standby Relay Application

With 110VAC supply and 10mA standby load, the circuit consumes typically only 150mW.

Once activated by the remote handset, the standard 12V relay can switch a 16A load.

Compact single output regulated power supply

Suggested fuse rating:

1A Slow Blow

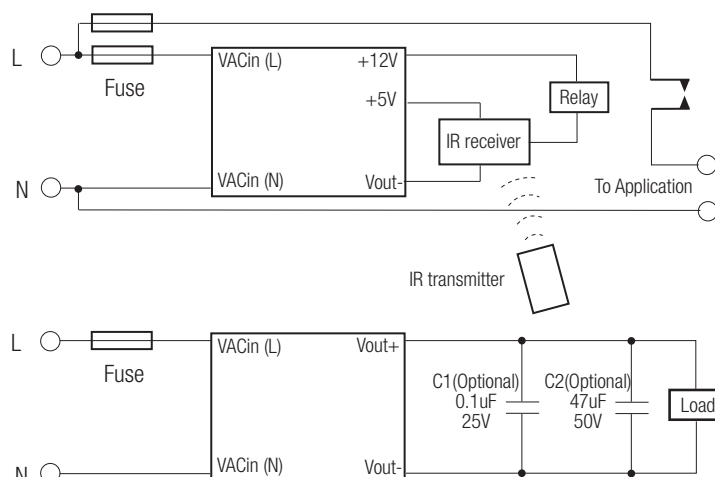

The product information and specifications are subject to change without prior notice. All products are designed for non-safety critical commercial and industrial applications. The Buyer agrees to implement safeguards that anticipate the consequences of any failures that might cause harm, loss of life and/or damage property.

Features

Regulated Converters

- Universal Input 80-264VAC or 115-370VDC
- Operating Temperature Range of -25°C to +85°C
- Isolated Output 3kVAC / 1 min
- Short Circuit and Overcurrent Protection
- Low Output Ripple & Noise
- Low Cost AC/DC Power Supply
- EN, UL and CE certified

Description

The new RAC04-SC modules are available with output voltages of 3.3, 5, 9, 12, 15, and 24V, and the input-to-output isolation is approximately 3kVAC/1min. With a standby consumption of typical 100mW, the mini power supplies are particularly suitable for energy-saving sleep mode and standby applications. Because of its compact design (height <17 mm), it is a versatile solution for home automation and other similar applications. Complete with an integrated input filter, the series has enhanced EMI performance and complies with EN55022, class B. The mini power supplies are also protected against short circuit with fully automatic restart after the error has been solved. The converters are EN/UL60950-1 certified and come complete with a 3 year warranty.

Selection Guide

Part Number	Input Voltage (VAC)	Output Voltage (VDC)	Output Current max. (mA)	Efficiency Typ. (%)	Capacitive Load (1+2) max.
RAC04-3.3SC	80-264	3.3	1200	67	5600µF
RAC04-05SC	80-264	5	800	72	2000µF
RAC04-09SC	80-264	9	444	76	1500µF
RAC04-12SC	80-264	12	333	74	560µF
RAC04-15SC	80-264	15	267	77	470µF
RAC04-24SC	80-264	24	167	77	150µF

Specifications (measured at TA 25°C, nominal input voltage, full load after warm-up)

Input Voltage Range (with Derating)	80-264VAC or 115-370VDC	
Input Frequency (for AC Input)	47-63Hz	
Input Current (Full Load)	115VAC / 230VAC	110mA / 72mA max.
Inrush Current	115VAC / 230VAC	30A / 60A max.
External Input Fuse Required	Recommended Value	1A - 1.5A / Slow Blow Type
No Load Power Consumption	80-264VAC	100mW typ. / 200mW max.
Output Voltage (Vout nom.)	3.3V-24V	
Output Current Range	167mA - 1200mA	
Output Voltage Tolerance	±2% typ. / ±5% max.	
Minimum Load	10% min.	
Output Ripple & Noise ⁽³⁾	(Full Load) 115VAC / 230VAC @ 20MHz limited	200mVp-p max.
Line Voltage Regulation	LL-HL at full Load	±0.5% typ. / ±1% max.
Load Voltage Regulation	10%-100% Load	±1.5% typ. / ±5% max.
Overcurrent Limit	105% - 155%	
Switching Frequency	at Full Load	40kHz typ.
Isolation Voltage	Input-Output	3kVAC / 1 minute
Leakage Current	0.85mA max.	
Isolation Resistance	Input-Output	1G Ω min
Isolation Capacitance	Input-Output	1000pF typ.
Short Circuit Protection	Hiccup, Auto Restart	
Operating Temperature Range	natural convection, without derating	-20°C to +60°C
	natural air convection, with derating	-25°C to +85°C
Storage Temperature Range	-40°C to +100°C	
Case Material	UL94V-0 black plastic	
Potting Material	Silicone	
Relative Humidity	95% RH max.	
Package Weight	30g typ.	
Package Quantity	12 pcs	

continued on next page

POWERLINE

AC/DC-Converter

with 3 year Warranty

RECOM

4 Watt Single Output



CE
E224736



EN-60950-1 certified
UL-60950-1 certified

RAC04-C

Derating Graph (Ambient Temperature)

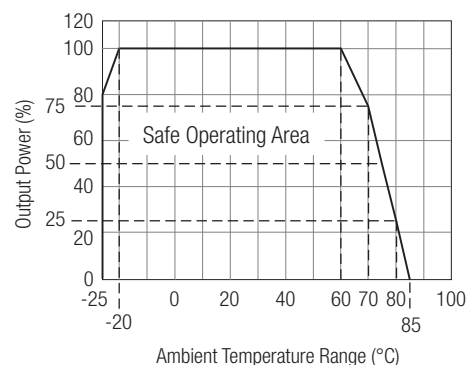

POWERLINE

AC/DC-Converter

RACO4-xxC

Series

Specifications (measured at TA 25°C, nominal input voltage, full load after warm-up)

Physical	Dimension (LxWxH)	37.80 x 23.90 x 16.40 mm
MTBF (+25°C)	MIL-HDBK-217F	500 * 10 ³ hours
EMI	Conducted and Radiated	EN55022, Class B
	Noise Immunity	EN55024
Safety Standard		
EN General Safety		EN-60950-1, 2nd Edition
UL General Safety	Report Number: E224736-A5-UL	UL-60950-1, 2nd Edition

115VAC

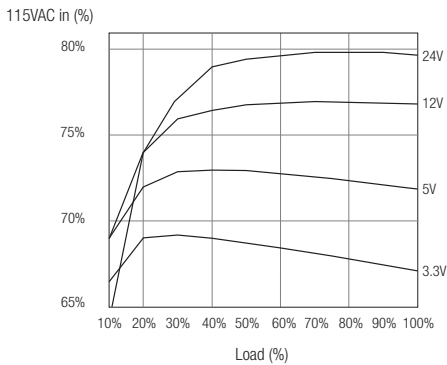

230VAC

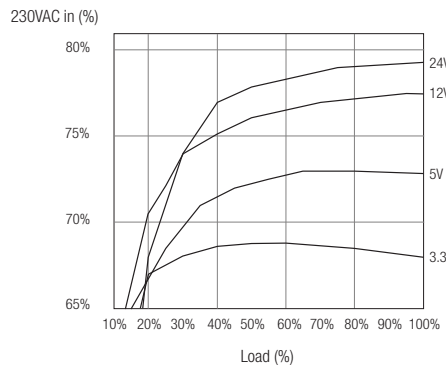

Input Voltage Derating Graph

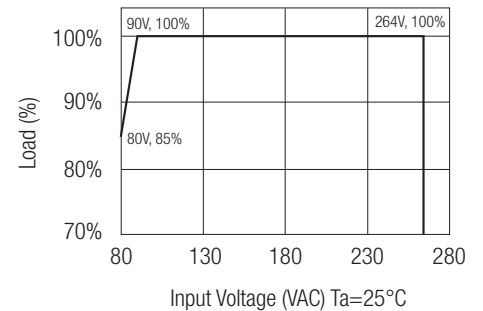

Notes:

1. Measured @230VAC / 50Hz
2. If used @ 115VAC / 60Hz with full load, please contact RECOM for detailed information.
3. To measure the output ripple & noise with short runs by 0.1uF/50V@20MHz, nominal input and full load.

Application Note

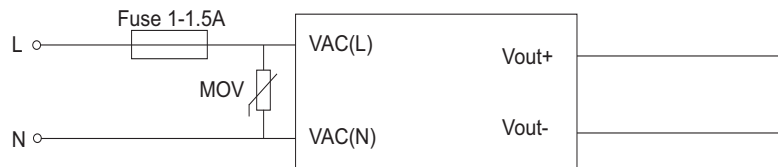

Recommended external input fuse 1.0 - 1.5A / slow blow type.

An external MOV is required for 230VAC operation. (MOV model: shall comply with IEC61051-2, e.g. Epcos S14 Series)

Package Style and Pinning

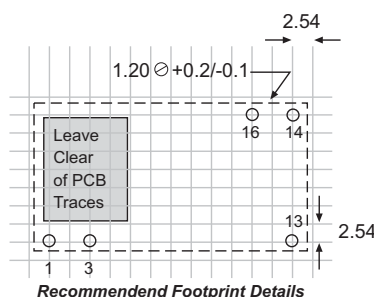
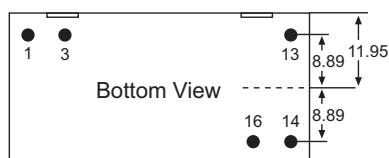
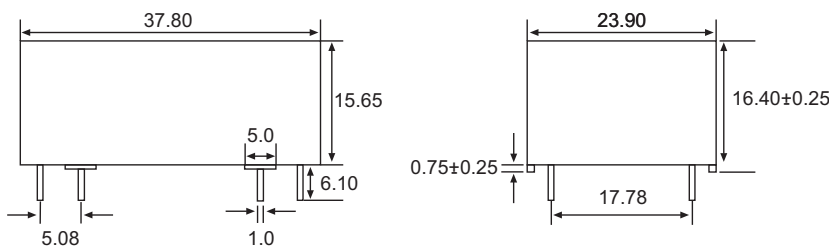

Pin Connections

Pin #	Single Out
1	VAC in (L)
3	VAC in (N)
13	NC
14	-VDC out
16	+VDC out

Tolerance ±0.5mm

Unless otherwise specified

The product information and specifications are subject to change without prior notice. All products are designed for non-safety critical commercial and industrial applications. The Buyer agrees to implement safeguards that anticipate the consequences of any failures that might cause harm, loss of life and/or damage property.

Features

Regulated Converters

- Universal Input 80-264VAC
- 100mW max No load Power Consumption
- Efficiency up to 79%
- High Operating Temperature Range (-40°C to +80°C)
- Isolated Output 3.75kVAC / 1 min
- Continuous Short Circuit Protection
- Meet EN55022 Class B
- EN, UL and CE Certified

Description

The RAC04-C/230 series are fully certified single and dual regulated AC/DC converters in an encapsulated PCB-mount package style with 3.75kVAC isolation and very low standby power consumption. The converters have SC protected single as well as dual outputs and meet EN55022 class B without any external components. Uses include board-level power supplies, home automation, instrumentation systems and standby applications.

Selection Guide

Part Number	Input Voltage (VAC)	Output Voltage (VDC)	Output Current (mA)	Efficiency (Typ.) (%)	Max. Capacitive Load** (µF)
RAC04-3.3SC/230	80-264	3.3	1200	72	10000
RAC04-05SC/230	80-264	5	800	75	7200
RAC04-12SC/230	80-264	12	333	77	1000
RAC04-15SC/230	80-264	15	267	78	820
RAC04-24SC/230	80-264	24	167	79	220
RAC04-0512DC/230	80-264	5/12	720/33	75	4700/100
RAC04-05DC/230	80-264	±5	400	76	3300/3300
RAC04-12DC/230	80-264	±12	166	78	680/680

** measured @115VAC

Specifications (measured at TA 25°C, full load after warm-up)

Input Voltage Range (with Derating)	80-264VAC or 113-373VDC	
Input Frequency	47-440Hz	
Input Current (Full Load)	115VAC/230VAC	98mA / 64mA max.
Inrush Current	115VAC/230VAC	15A / 30A max.
No Load Power Consumption	115VAC/230VAC 50/60Hz	100mW max.
Output Voltage Accuracy (Full Load)	Single Outputs	±2% typ.
	Dual Outputs	±2% typ.
Line Voltage Regulation (90-264VAC)	5V / 12V	±2% / ±10% typ.
	Single Outputs	±0.2% typ.
Load Voltage Regulation (10% - 100% load)	Dual Outputs	±0.2% typ.
	5V / 12V	±0.2% / ±1% typ.
Output Ripple&Noise (measured @ 20MHz of bandwidth with 0.1µF & 47µF parallel capacitors)	3.3V/5V Output	±1% typ.
	All Others	±0.5% typ.
Switching Frequency (Full Load)	5V / 12V	±1% / ±5% typ.
	200mVp-p typ.	
Hold-Up Time	115VAC	15ms min.
Minimum Load		0%
Isolation Voltage	Input-Output	3.75kVAC / 1minute
Leakage Current	230VAC / 50Hz	0.25mA max.
Isolation Resistance		100M Ω min.

continued on next page

POWERLINE

AC/DC-Converter

with 3 year Warranty

RECOM

4 Watt Single & Dual Output



EN-60950-1 certified
UL-60950-1 certified

RAC04-C/230

Derating Graph (Ambient Temperature)

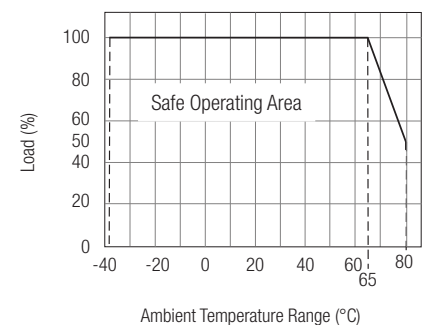

Specifications (measured at TA 25°C, full load after warm-up)

Short Circuit Protection		Auto Recovery
Operating Temperature Range	Natural Convection	-40°C to +65°C (without Derating) -40°C to +80°C (with Derating)
Storage Temperature Range		-40°C to +100°C
Case Material		UL94V-0 Black Plastic
Relative Humidity	Non-condensing	95% RH max.
Package Weight		31.5g typ.
Dimension	(L x W x H)	36.7 x 27.2 x 17.1mm
EMC	Conducted and Radiated	EN55022 Class B
	Noise Immunity	EN55024
MTBF (+25°C)	MIL-HDBK-217F	500 x 10 ³ hours
Certification	CE	EN55022 Class B
	UL General Safety	Report: E224736 UL60950-1, 2nd Edition
	EN General Safety	Report: SPCLVD1210098 EN60950-1, 2nd Edition + A12:2011

Efficiency vs Load

Single Output 115VAC

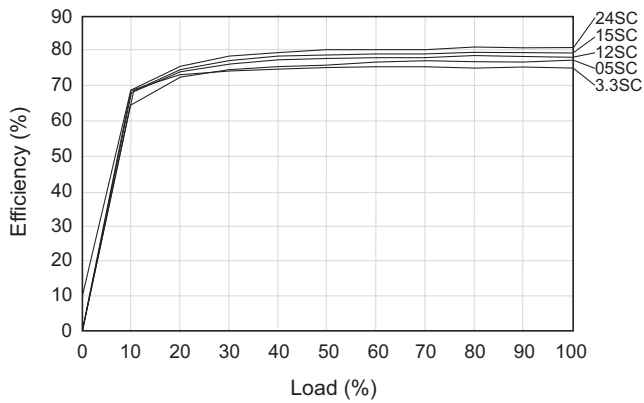

Dual Output 115VAC

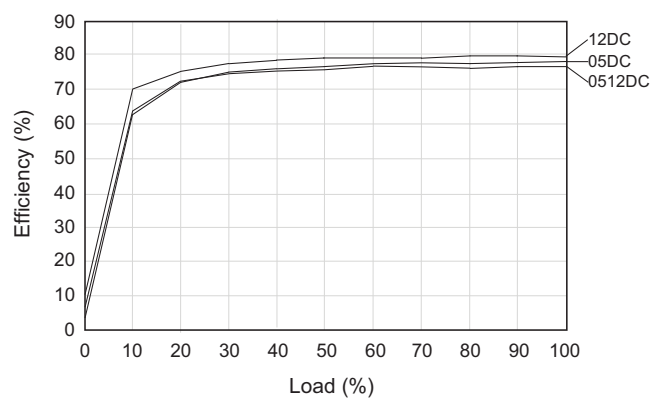

Single Output 230VAC

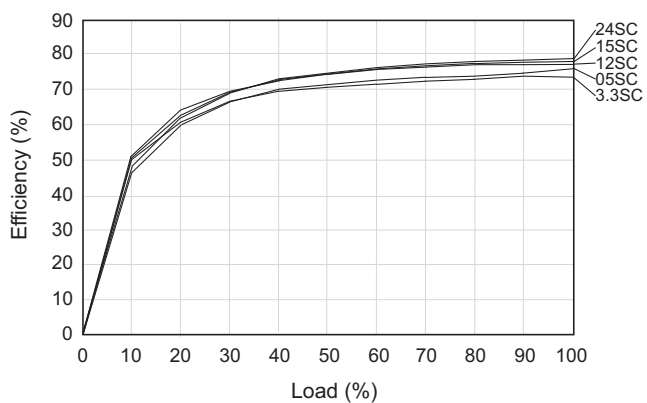

Dual Output 230VAC

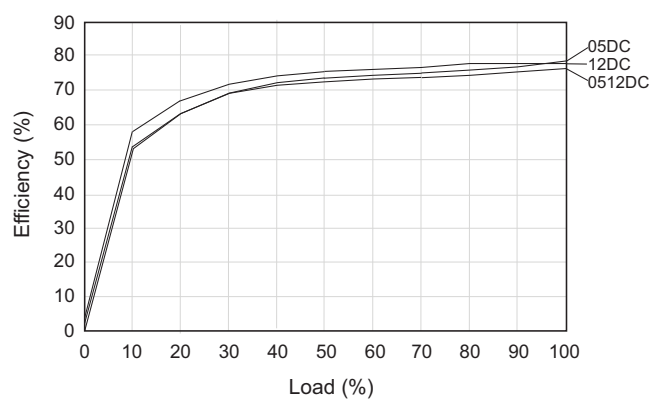

Specifications (measured at TA 25°C, full load after warm-up)

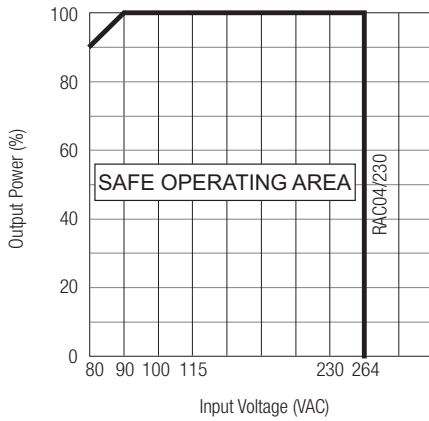

Application Note:

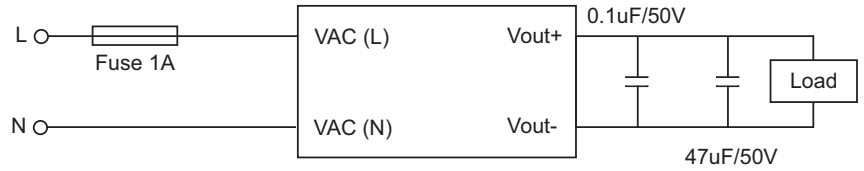

1. Recommended external input fuse 1A/slow blow type.
2. To measure the output ripple & noise connect 0.1uF/50V & 47uF/50V @20MHz, as close to pins as possible with nominal input and full load. Please see above.

Package Style and Pinning

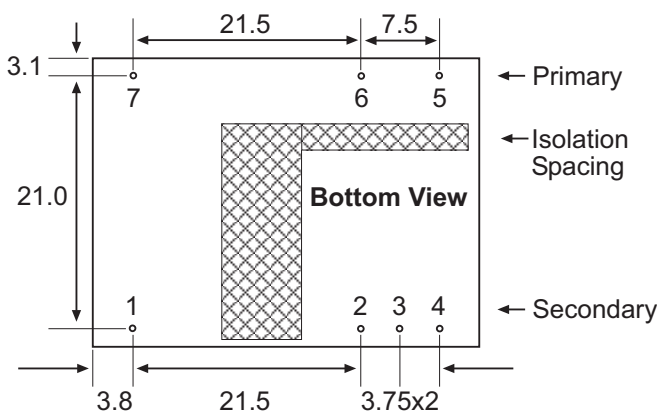
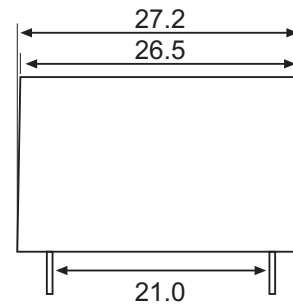
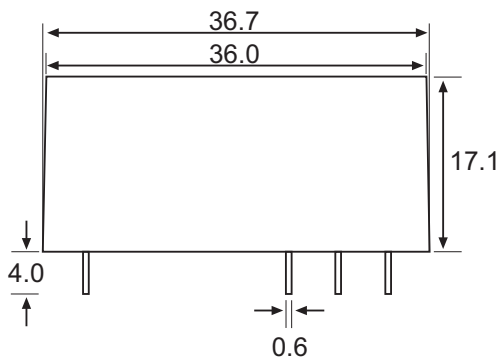

Pin Connections

Pin #	Single Out	Dual Output	Dual Output
1	No Pin	No Pin	No Pin
2	+VDC out	+Vout	+Vout
3	-VDC out	Com	Com
4*	NC	-Vout	+12V
5	VAC in (L)	VAC in (L)	VAC in (L)
6	VAC in (N)	VAC in (N)	VAC in (N)
7*	NC	NC	NC

NC = No Connection

xx.x = ±0.5mm

xx.xx = ±0.25mm

* Pins 4 and 7 are NC but need 4mm minimum clearance to ground for safety.

The product information and specifications are subject to change without prior notice. All products are designed for non-safety critical commercial and industrial applications. The Buyer agrees to implement safeguards that anticipate the consequences of any failures that might cause harm, loss of life and/or damage property.

Features

Regulated Converters

- Universal Input 80-305VAC
- High efficiency up to 79%
- Isolated Output 3.75kVAC / 1 min
- Short Circuit Protection
- Maximum No Load <50mW, Maximum Input Power <0.5W @0.3W Output Power
- Meet EN55022 Class B
- Fixed Output Voltage

Selection Guide

Part Number	Input Voltage (VAC)	Output Voltage (VDC)	Output Current (mA)	Efficiency (Typ.) (%)	Max. Capacitive Load (1+2)
RAC04-3.3SC/277	80-305	3.3	1200	72	10000µF
RAC04-05SC/277	80-305	5	800	75	7200µF
RAC04-12SC/277	80-305	12	333	78	1000µF
RAC04-15SC/277	80-305	15	267	79	820µF
RAC04-24SC/277	80-305	24	167	79	220µF
RAC04-0512DC/277	80-305	5/12	720/33	75	4700/100µF
RAC04-05DC/277	80-305	±5	±400	76	±3300µF
RAC04-12DC/277	80-305	±12	±166	78	±680µF

Specifications (measured at TA 25°C, full load after warm-up)

Input Voltage Range (with Derating)	80-305VAC or 113-430VDC	
Input Frequency	47-440Hz	
Input Current (Full Load)	115VAC/230VAC	98mA / 64mA max.
Inrush Current	115VAC/230VAC	15A / 30A max.
No Load Power Consumption	115VAC/230VAC/277VAC / 50/60Hz	50mW max.
Output Voltage Accuracy (Full Load)	Single Outputs	±2% typ.
	Dual Outputs	±2% typ.
Line Voltage Regulation (90-305VAC)	5V/12V	±2% / ±10% typ.
	Single Outputs	±0.2% typ.
	Dual Outputs	±0.2% typ.
Load Voltage Regulation	5V/12V	±0.2% / ±1% typ.
	3.3V/5V Output	±1% typ.
(5V Minimum Load 5% @12V Full Load)	All Others	0.5% typ.
	5V/12V	±1% / ±5% typ.
Output Ripple&Noise	200mVp-p typ.	
(measured @ 20MHz BW with 0.1µF & 47µF parallel capacitor)		
Switching Frequency (Full Load)	67kHz	
Hold-Up Time (@115VAC)	15ms min.	
Minimum Load	5V/12V	5% / 0% typ.
	All Others	0%
Isolation Voltage	Input-Output	3.75kVAC / 1 minute
Leakage Current	277VAC / 50Hz	0.25mA max.
Isolation Resistance	100M Ω min.	
Short Circuit Protection	Auto Recovery	
Operating Temperature Range	-25°C to +65°C (without Derating)	
(Natural Convection, with Derating)	-25°C to +80°C (with Derating)	
Storage Temperature Range	-40°C to +100°C	
Case Material	UL94V-0 Black Plastic	

continued on next page

POWERLINE

AC/DC-Converter

with 3 year Warranty

RECOM

4 Watt Single / Dual Output



EN-60950-1 Certified

UL-60950-1 Certified

RAC04-C/277

Derating Graph (Ambient Temperature)

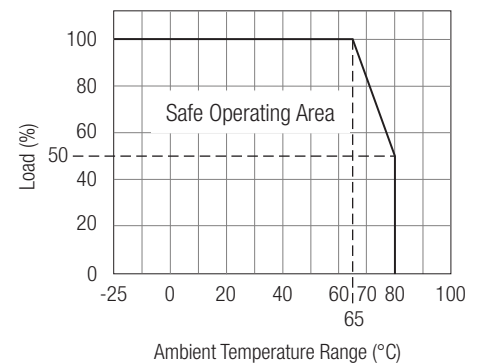

Refer to Application Notes

Specifications (measured at TA 25°C, full load after warm-up)

Relative Humidity	Non Condensing	95% RH max.
Package Weight		31.5g typ.
Physical Dimenstions	(LxWxH)	36.7x27.2x17.1 mm
EMC	Conducted and Radiated	EN55022 Class B
	Noise Immunity	EN55024
MTBF (+25°C)	MIL-HDBK-217F	500 x 10 ³ hours
Certification	UL General Safety (Report: E224736-A18-UL) EN General Safety (Report: SPCLVD1310079-1) CB General Safety (Report: 131055-1CB-M1)	UL60950-1, 2nd Edition EN60950-1, 2006 IEC 60950-1: 2005; 2nd Edition

Notes:

Note1: Measured @ 230VAC / 50Hz / Ta=25°C with constant resistant mode at full load.

Note2: If used @ 115VAC / 60Hz with full load, max. capacitive load is less, please contace RECOM for detailed information.

Specifications (measured at TA 25°C, full load after warm-up)

RAC04-3.3SC/277

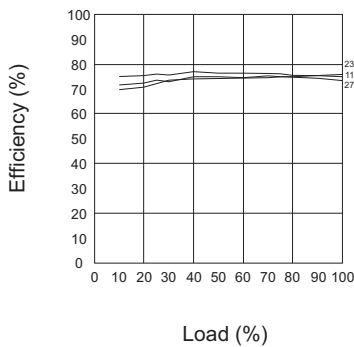

RAC04-05SC/277

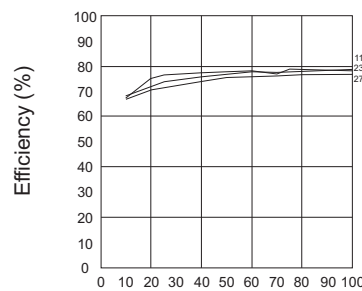

RAC04-12SC/277

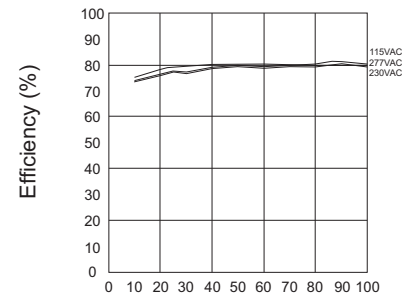

RAC04-15SC/277

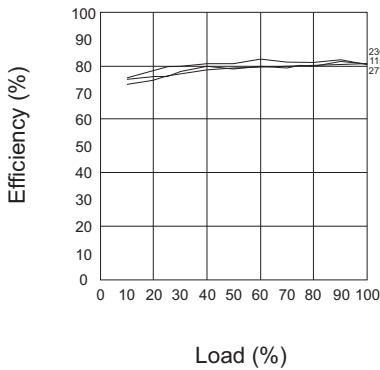

RAC04-05DC/277

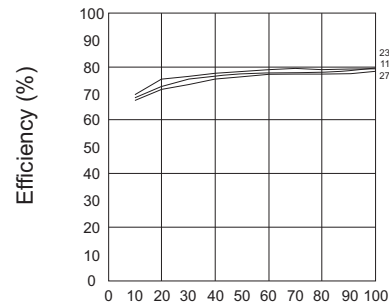

RAC04-12DC/277

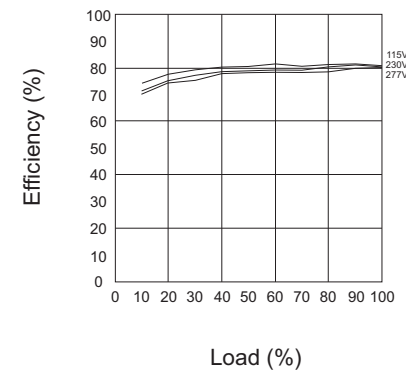

RAC04-0512DC/277

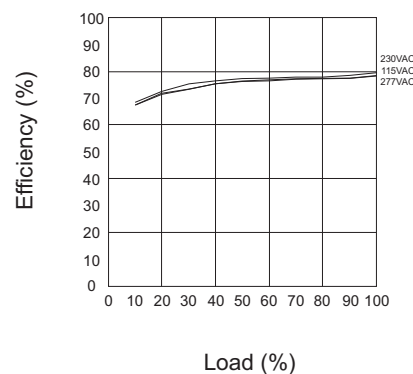

Specifications (measured at TA 25°C, full load after warm-up)

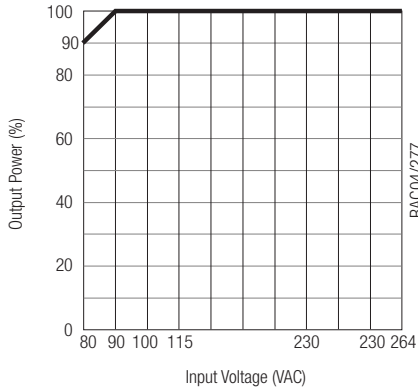

Application Note:

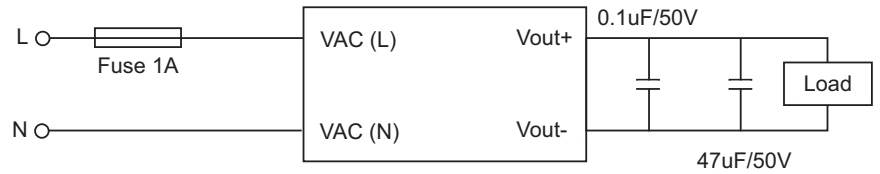

1. Recommended external input fuse 1A/slow blow type.
2. To measure the output ripple & noise short runs by 0.1uF/50V&47uF/50V @20MHz, nominal input and full load. Please see as above.
3. That Pin 7 is NC but need 4mm minimum clearance to ground for safety.

Package Style and Pinning

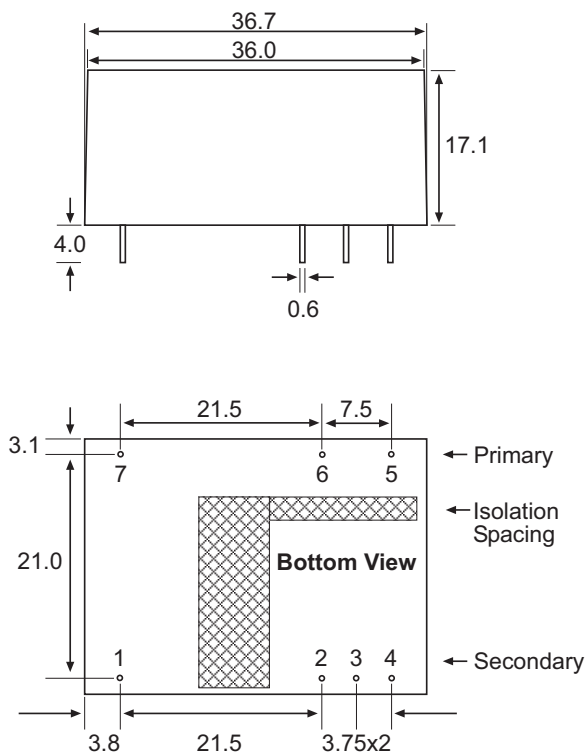

Pin Connections

Pin #	Single Out	Dual Output	Dual Output
1	No Pin	No Pin	No Pin
2	+VDC out	+Vout	+Vout
3	-VDC out	Com	Com
4	NC	-Vout	+12V
5	VAC in (L)	VAC in (L)	VAC in (L)
6	VAC in (N)	VAC in (N)	VAC in (N)
7	NC	NC	NC

NC = No Connection
xx.x = ±0.5mm
xx.xx = ±0.25mm

Features

Regulated Converters

- AC-DC Power Supply
- 5 Watt PCB Mount Package
- Universal Input Voltage Range
- 3000VAC Isolation
- Low Output Ripple and Noise
- Short Circuit Protected
- UL Approved, CE Marked

Description

Compact UL certified switching AC/DC power module for PCB, screw-terminal connection or DIN-rail mounting.

Selection Guide

Part Number	Input Range (VAC)	Output Voltage (VDC)	Output Current (mA)	Efficiency (%)	Max Capacitive Load
RAC05-3.3SA	90-264	3.3	1500	62	40000µF
RAC05-05SA	90-264	5	1000	65	19000µF
RAC05-12SA	90-264	12	416	70	4000µF
RAC05-15SA	90-264	15	333	70	3500µF
RAC05-24SA	90-264	24	200	71	900µF
RAC05-05DA	90-264	±5	±500	70	±9500µF
RAC05-12DA	90-264	±12	±200	67	±1400µF
RAC05-15DA	90-264	±15	±160	67	±950µF

*add suffix "-E" for extended temperature range, e.g. RAC05-05SA-E

*add suffix "-ST" for screw terminal module e.g. RAC05-05SA-ST, RAC05-05DA-E-ST

Specifications (typical at 25°C and after warm up time unless otherwise specified)

Input Voltage Range	90-264VAC or 120-370VDC	
Rated Power	5 Watts max	
Input Frequency Range (for AC Input)	47-440Hz	
Input Current (full load)	115VAC/230VAC	120mA /70mA max.
No Load Power Consumption	115VAC/230VAC	1.18W max.
Inrush Current (<2ms)	115VAC	10A max. (-E = 23A max.)
	230VAC	20A max. (-E = 46A max.)
Leakage Current	0.75mA max	
Output Voltage Accuracy (full load)	±2%	
Line Voltage Regulation (low line, high line at full load)	±0.3% typ	
Load Voltage Regulation (5% to 100% full load)	±0.5% typ	
Output Ripple and Noise (20MHz limited)	Ripple	<0.2% Vout + 40mVp-p max
	Noise	0.5% Vout + 50mVp-p max
Operating Frequency	100kHz typ	
Efficiency at full Load	see table	
RMS Isolation Voltage (input to output)	3kVAC / 1minute	
Temperature Coefficient	±0.02%/°C typ	
Isolation Resistance	100 MΩ max	
Short Circuit Protection	Hiccup, Automatic Restart	
Operating Temperature Range	Standard	-25°C to +70°C
(free air convection, with derating)	Suffix -E	-40°C to +70°C
Storage Temperature Range	-40°C to +85°C	
Humidity	95% RH max	
Case Material	Epoxy with Fibreglass (UL94V-0)	
Package Weight	80g	
Packing Quantity	5 pcs (-ST Version: 1 pc)	
EMC	EN 55022 ClassB / EN 50082-1	
MTBF (+25°C)	using MIL-HDBK-217F	300 x 10 ³ hours

POWERLINE

AC/DC-Converter

with 3 year Warranty

RECOM

5 Watt Single/Dual Output

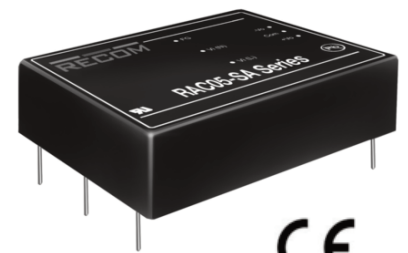

UL-60950-1 Certified

RAC05-A

Derating Graph (Ambient Temperature)

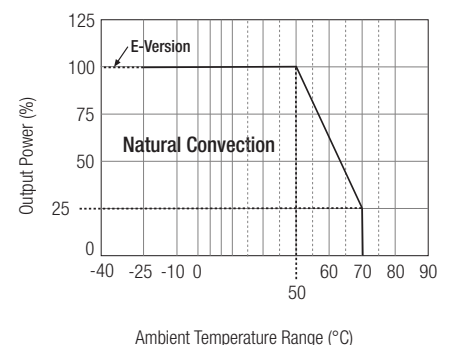

Refer to Application Notes

www.recom-international.com

POWERLINE

AC/DC-Converter

RAC05-S_DA Series

Screw Terminal Module Option (suffix -ST)

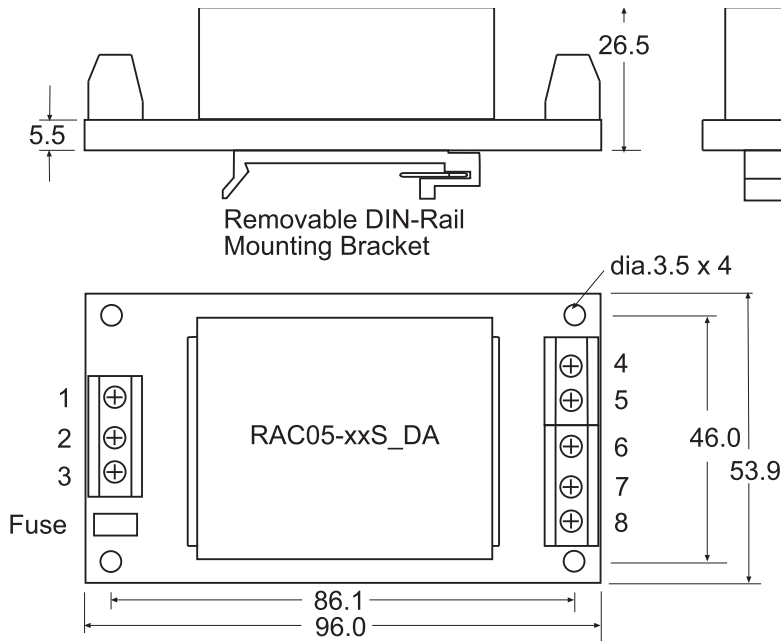

Pin Connections-

Pin #	Single Out	Dual Out
1	FG	FG
2	VAC in (N)	VAC in (N)
3	VAC in (L)	VAC in (L)
4	NC	NC
5	-VDC out	-VDC out
6	NC	Com
7	+VDC out	+VDC out
8	NC	NC

NC = No Connection

Standard Package Style and Pinning

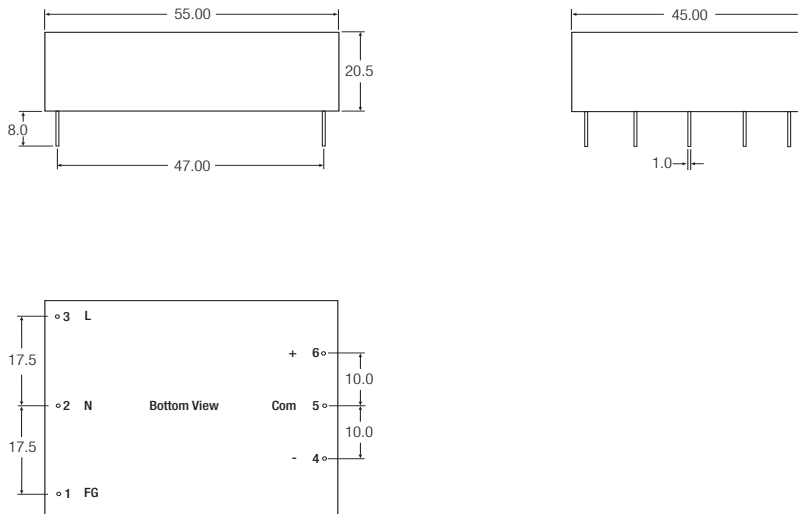

Pin Connections-

Pin #	Single Out	Dual Out
1	FG	FG
2	VAC in (N)	VAC in (N)
3	VAC in (L)	VAC in (L)
4	-VDC out	-VDC out
5	No Pin	Com
6	+VDC out	+VDC out

XX.X ± 0.5 mm
XX.XX ± 0.25 mm

Standard Application Circuit

Suggested fuse rating
1A Slow Blow

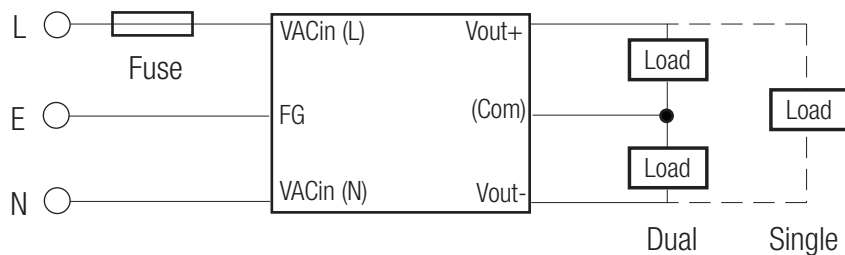

The product information and specifications are subject to change without prior notice. All products are designed for non-safety critical commercial and industrial applications. The Buyer agrees to implement safeguards that anticipate the consequences of any failures that might cause harm, loss of life and/or damage property.

Features

Regulated Converters

- Very Compact AC-DC Power Supply
- 5 Watt PCB Mount Package
- Universal Input Voltage Range
- 3000VAC Isolation
- Low Output Ripple and Noise
- Short Circuit Protected
- Very Low No Load Power Consumption
- UL Certified, CE Marked

Description

Compact UL certified switching AC/DC power module for PCB, screw-terminal connection or DIN-rail mounting.

Selection Guide

Part Number	Input Range (VAC)	Output Voltage (VDC)	Output Current (mA)	Efficiency (%)	Max. Capacitive Load
RAC05-3.3SB	90-264	3.3	1250	68	13800µF
RAC05-05SB	90-264	5	1000	71	6000µF
RAC05-12SB	90-264	12	420	75	1400µF
RAC05-15SB	90-264	15	333	75	1000µF
RAC05-24SB	90-264	24	230	77	170µF

*add suffix "-E" for extended temperature range, e.g. RAC05-05SB-E

*add suffix "-ST" for screw terminal module e.g. RAC05-05SB-ST, RAC05-05SB-E-ST

Specifications (typical at 25°C and after warm up time unless otherwise specified)

Input Voltage Range	90-264VAC or 120-370VDC	
Rated Power	5 Watts max.	
Input Frequency Range (for AC Input)	47-440Hz	
Input Current (full load)	115VAC/230VAC	110mA / 70mA max.
No Load Power Consumption	115VAC/230VAC	80mW max.
Inrush Current (<2ms)	115VAC	10A max. (-E = 23A max.)
	230VAC	20A max. (-E = 46A max.)
Leakage Current	0.75mA max.	
Output Voltage Accuracy (Full load)	±2%	
Line Voltage Regulation (low line, high line at full load)	±0.3% typ.	
Load Voltage Regulation (5% to 100% full load)	±0.5% typ.	
Output Ripple and Noise (20MHz limited)	Noise	0.5% Vout + 50mVp-p max.
	Ripple	<0.2% Vout + 40mVp-p max.
Operating Frequency	132kHz typ.	
Efficiency at Full Load	see table	
RMS Isolation Voltage (input to output)	3kVAC / 1minute	
Temperature Coefficient	±0.02%/°C typ.	
Isolation Resistance	100 MΩ max.	
Short Circuit Protection	Hiccup, Automatic Restart	
Operating Temperature Range	Standard	-25°C to +70°C
(free air convection, with derating)	Suffix -E	-40°C to +70°C
Storage Temperature Range	-40°C to +85°C	
Humidity	95% RH max.	
Case Material	Epoxy with Fibreglass (UL94V-0)	
Package Weight	30g	
Packing Quantity	9 pcs (-ST Version: 1 pc)	
EMC	EN 55022 Class B / EN 55024	
MTBF (+25°C)	using MIL-HDBK-217F	360 x 10 ³ hours

POWERLINE

AC/DC-Converter

with 3 year Warranty

RECOM

5 Watt Single Output



UL-60950-1 Certified

RAC05-B

Derating Graphs (Ambient Temperature)

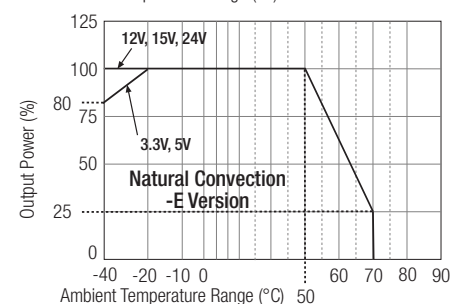
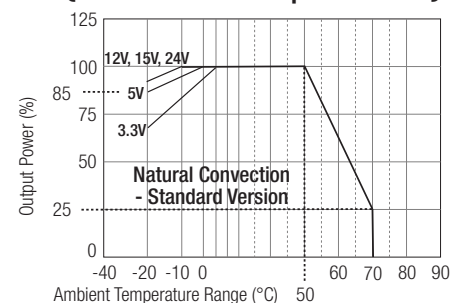

Refer to Application Notes

www.recom-international.com

POWERLINE

AC/DC-Converter

RAC05-SB Series

Screw Terminal Module Option (suffix -ST)

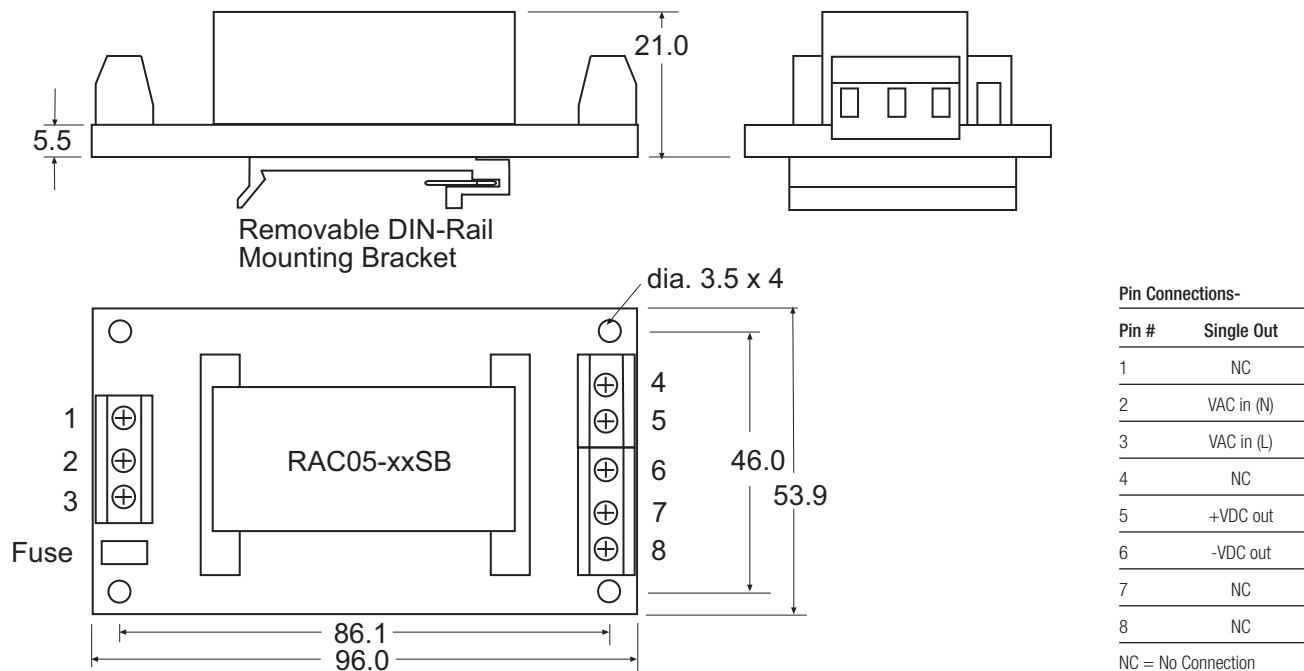

Package Style and Pinning

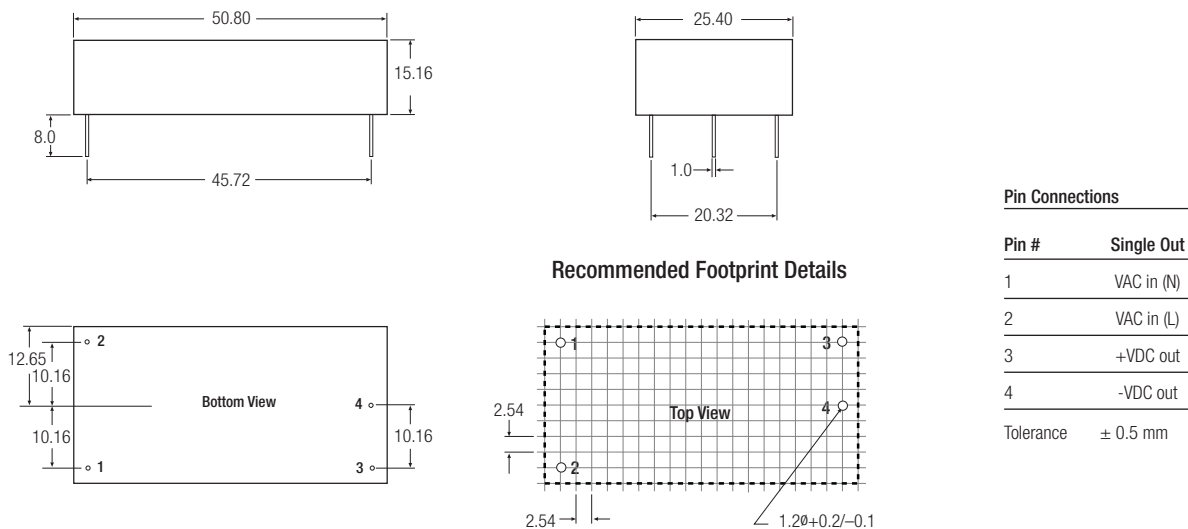

Standard Application Circuit

Suggested fuse rating
1A Slow Blow

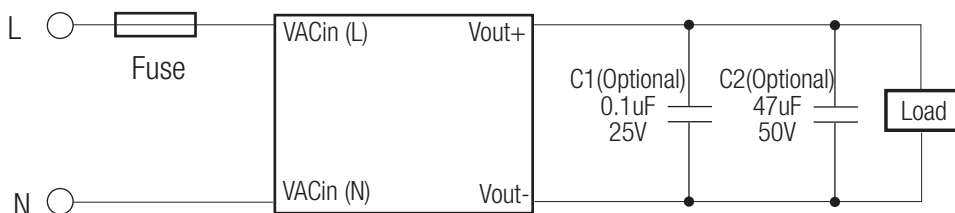

Please Read Application Notes

The product information and specifications are subject to change without prior notice. All products are designed for non-safety critical commercial and industrial applications. The Buyer agrees to implement safeguards that anticipate the consequences of any failures that might cause harm, loss of life and/or damage property.

RAC05-B

Features

Regulated Converters

- Universal Input 80-264VAC
- High efficiency up to 77%
- Isolated Output 3kVAC / 1 min
- Short Circuit Protection
- Meet EN55022 Class B
- Low Standby Power Consumption

Description

Compact, low cost, high efficiency, universal input switching AC/DC power module for PCB or wired mounting with single or dual outputs. CE marked and UL/cUL certified.

Selection Guide

Part Number	Input Voltage (VAC)	Output Voltage (VDC)	Output Current (max.)	Efficiency (Typ.)	Max. Capacitive Load (1+2)
RAC05-3.3SC*	80-264	3.3	1250	70	12000µF
RAC05-05SC*	80-264	5	1000	73	6800µF
RAC05-09SC*	80-264	9	556	75	2500µF
RAC05-12SC*	80-264	12	420	76	1500µF
RAC05-15SC*	80-264	15	340	76	750µF
RAC05-24SC*	80-264	24	210	77	330µF
RAC05-05DC*	80-264	±5	±500	73	±3000µF
RAC05-12DC*	80-264	±12	±210	76	±560µF
RAC05-15DC*	80-264	±15	±170	76	±220µF

* add suffix /W for wired version

Specifications (measured at TA 25°C, full load after warm-up)

Input Voltage Range (with derating)	80-264VAC or 115-370VDC	
Rated Power	5 Watts max.	
Input Frequency (for AC Input)	47-440Hz	
Input Current (Full Load)	115VAC / 230VAC	110mA / 70mA typ.
Inrush Current (<2ms)	115VAC / 230VAC	30A / 60A max.
Minimum Load (Specifications valid with 5% min.)	0%	
No Load Power Consumption	0.25W max.	
Recommended External Input Fuse	1.5A / Slow Blow Type	
Output Voltage Accuracy (Full Load)	115VAC / 230VAC	±2% max.
Line Voltage Regulation (Full Load)	LL-HL	±0.3% typ.
Load Voltage Regulation	5-100% Load	±0.5% typ.
Output Ripple&Noise @115/230VAC	3.3V	120mV max.
(20MHz limited with 100nF across output)	All Others	150mV max.
Switching Frequency (Full Load)	132kHz typ.	
Efficiency (Full Load)	see Selection Guide	
Hold-Up Time (Full Load)	115VAC	10ms typ.
Leakage Current	0.85mA max.	
Isolation Voltage	Input-Output	3kVAC / 1minute
Isolation Capacitance	Input-Output	1000pF typ.
Isolation Resistance	Input-Output	1G Ω min.
Short Circuit Protection	Hiccup, Automatic Restart	
Oversvoltage Protection (of Nominal Output Voltage)	3.3V	4.8V - 5.4V
Operating Temperature Range (Natural Convection)	-25°C to +55°C (without Derating) -25°C to +75°C (with Derating)	
Storage Temperature Range	-40°C to +100°C	
Case Material	UL94V-0 Black Plastic	

continued on the next page

POWERLINE

AC/DC-Converter

with 3 year Warranty

RECOM

5 Watt Single / Dual Output

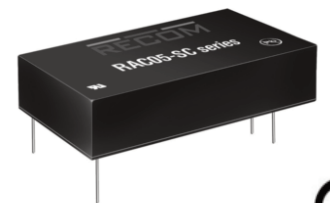

EN-60950-1 Certified
UL-60950-1 Certified

RAC05-C

Derating Graph

(Ambient Temperature)

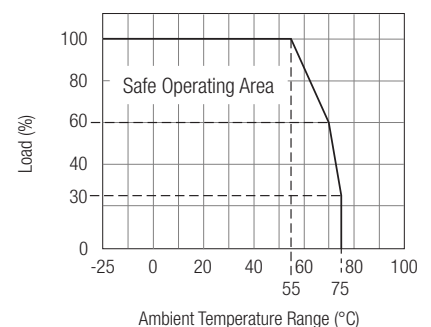

Refer to Application Notes

Specifications (measured at TA 25°C, full load after warm-up)

Potting Material		Epoxy UL94V-0
Relative Humidity		95% RH max.
Package Weight		35g / 38g
Packing Quantity	Single Output	10pcs
	Dual Output	9pcs
	Wired Version	1pc
MTBF (25°C)	Using MIL-HDBK 217F	>400 x 10 ³ hours
(65°C)	Using MIL-HDBK 217F	>200 x 10 ³ hours
Emmissions	CE	EN 55022: 2006 + A1: 2007 / Class B
	EMC	EN 55024:1998 + A1:2001 + A2:2003
	Harmonics	EN 61000-3-2:2006 / Class A
	Flicker	EN 61000-3-3:1995 + A1:2001 +A2:2005
Immunity	ESD	IEC 61000-4-2 / Criterion B
	RS	IEC 61000-4-3 / Criterion A
	EFT	IEC 61000-4-4 / Criterion B
	Surge	IEC 61000-4-5 / Criterion B
	CS	IEC 61000-4-6 / Criterion A
	PMF	IEC 61000-4-8 / Criterion A
	Voltage Variations	IEC 61000-4-11 / Criteria B + C
Certifications:		
UL General Safety	Report: E224736	UL-60950-1, 2nd Edition
cUL	Report: E224736	C22.2 No. 60950-1-07, 2nd Edition
EN General Safety	Report: SPCLVD1211033-1	EN-60950-:2006 + A12:2011
CE		EN55022 Class B

Notes:

Note1: Measured @230VAC / 50Hz / Ta=25°C with constant resistant mode at full load.

Note2: If used @115VAC / 60Hz with full load, max. capacitive load is less, please contact RECOM for detailed information

Typical Characteristics

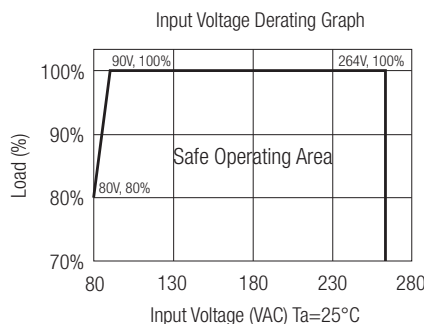
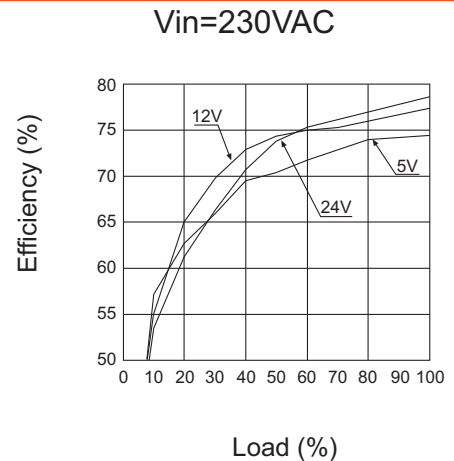
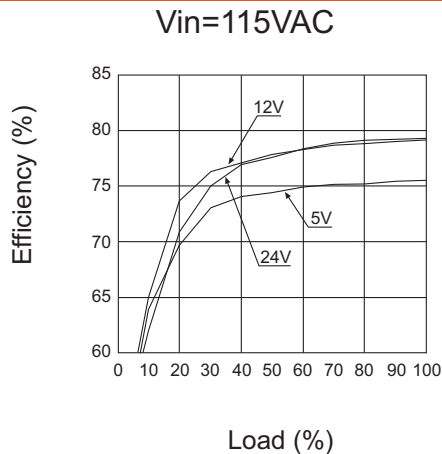

Package Style and Pinning

PCB Mout Version (Standard)

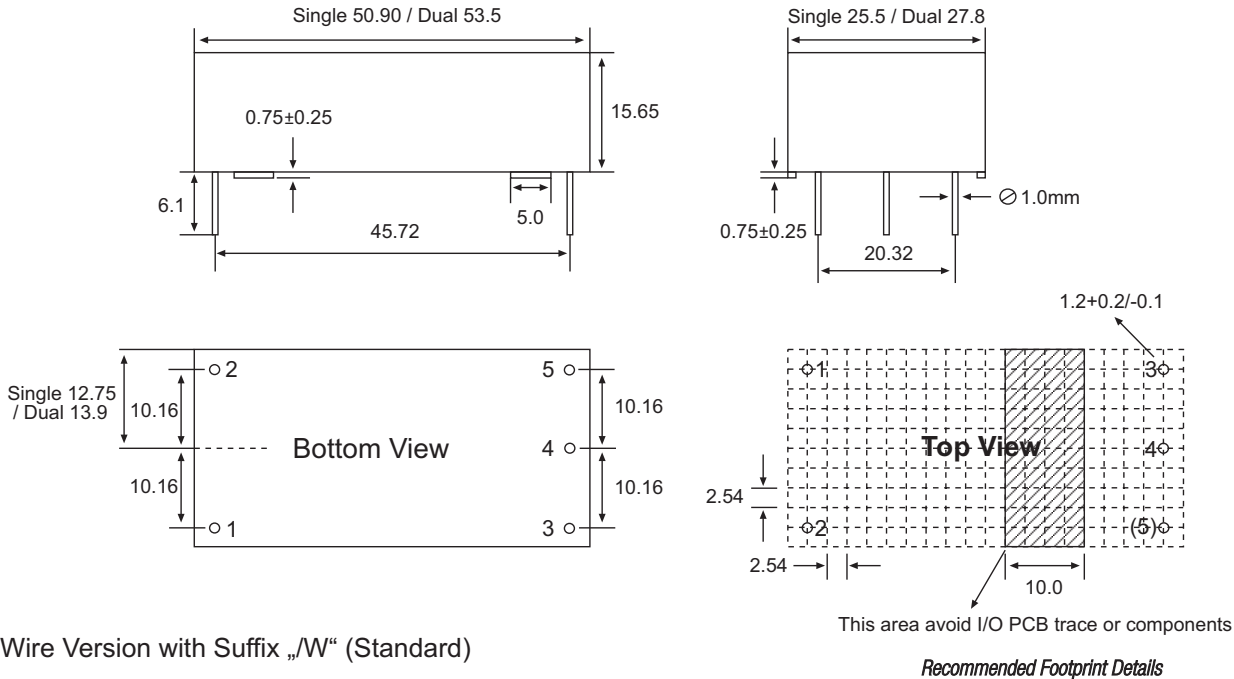

Wire Version with Suffix „W“ (Standard)

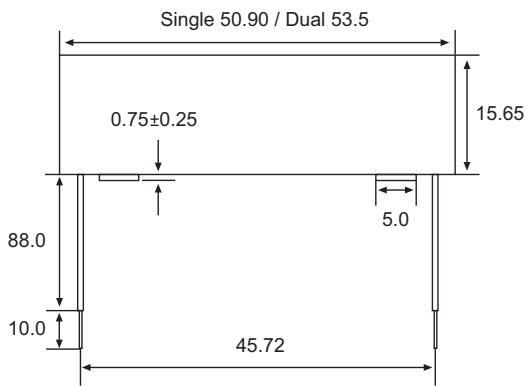

Pin Connections

Pin #	Single Out	Dual Out
1	VAC in (N)	VAC in (N)
2	VAC in (L)	VAC in (L)
3	+VDC out	+VDC out
4	-VDC out	Com
5	no Pin	-VDC out

NC = No Connection
xx.x = ±0.5mm
xx.xx = ±0.25mm

Wire Connections

Pin #			Single out	Dual out
1 (Blue)	AWG#22	1015	VAC in (N)	VAC in (N)
2 (Brown)	AWG#22	1015	VAC in (L)	VAC in (L)
3 (Red)	AWG#22	1007	+VDC out	+VDC out
4 (Black)	AWG#22	1007	-VDC out	Common
5 (Orange)	AWG#22	1007	no Wire	-VDC out

NC = No Connection
xx.x = ±0.5mm
xx.xx = ±0.25mm

Features

Regulated Converters

- Very Compact AC-DC Power Supply
- 6 Watt PCB Mount Package
- Single and Dual Output Versions
- Universal Input Voltage Range
- Class II Power Supply with 3kVAC Isolation
- Low Output Ripple and Noise
- Short Circuit, Overload, Overtemp Protected
- Low Standby Power Consumption
- UL/cUL Certified, CE Marked

Description

Compact, low cost, high efficiency, universal input switching AC/DC power module for PCB or wired mounting with single or dual outputs. CE marked and UL/cUL Certified.

Selection Guide

Part Number	Input Range (VAC)	Output Voltage (VDC)	Output Current (mA)	Efficiency (%)	Max Capacitive Load ⁽¹⁺²⁾
RAC06-3.3SC*	80-264	3.3	1500	70	12000µF
RAC06-05SC*	80-264	5	1200	75	6800µF
RAC06-09SC*	80-264	9	667	77	2500µF
RAC06-12SC*	80-264	12	500	78	1500µF
RAC06-15SC*	80-264	15	400	79	750µF
RAC06-24SC*	80-264	24	250	79	330µF
RAC06-05DC*	80-264	±5	±600	75	±3300µF
RAC06-12DC*	80-264	±12	±250	78	±680µF
RAC06-15DC*	80-264	±15	±200	79	±330µF

* add suffix /W for wired version

Specifications (measured at TA 25°C, full load after warm-up)

Input Voltage Range (with derating)	80-264VAC or 115-370VDC	
Rated Power	6 Watts max.	
Input Frequency Range (for AC Input)	47-440Hz	
Input Current (full load)	115/230VAC	120mA / 78mA typ.
No Load Power Consumption	250mW max.	
Inrush Current (<2ms)	115/230VAC	30A/60A max.
Holdup Time (Full Load)	115VAC	10ms typ.
Leakage Current	0.85mA max.	
Output Voltage Accuracy (Full load)	±2% max.	
Line Voltage Regulation (low line, high line at full load)	±0.3% typ.	
Load Voltage Regulation (5% to 100% full load)	±0.5% typ.	
Output Ripple and Noise (20MHz BW)	3.3V Output	120mVp-p max.
(with 100nF across each output)	All Others	150mVp-p max.
Operating Frequency (full load)	132kHz typ.	
Minimum Load = 0%	specifications valid for 5% minimum load only	
RMS Isolation Voltage (input to output)	3kVAC / 1minute	
Isolation Resistance (input to output)	1 GΩ min.	
Isolation Capacitance (input to output)	1000pF typ.	
Short Circuit Protection	Hiccup, Automatic Restart	
Overload Protection	115VAC/230VAC	115% ~ 145%
Output Overvoltage Protection	Zener Diode Clamp	
(set at 4.8V - 5.4V for 3.3V and others 110% - 135% of its Nominal Output Voltage)		

continued on next page

POWERLINE

AC/DC-Converter

with 3 year Warranty

RECOM

6 Watt Single/Dual Output



E224736

EN-60950-1 Certified

UL-60950-1 Certified

RAC06-C

Derating Graph (Ambient Temperature)

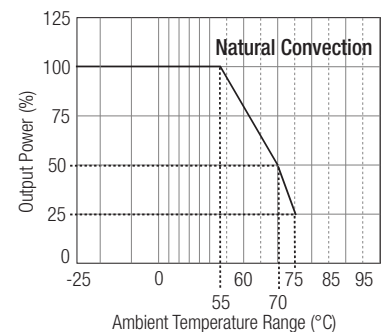

Refer to Application Notes

Specifications (measured at TA 25°C, full load after warm-up)

Operating Temperature Range	(free air convection, without derating)	-25°C to +55°C
	(free air convection, with derating)	-25°C to +75°C
Storage Temperature Range		-40°C to +100°C
Recommended External Input Fuse		1.5A Slow Blow
Humidity		95% RH max.
Case Material	Plastic Case filled with Epoxy (UL94V-0)	
Package Weight	Single/Dual	35g/38g
Packing Quantity	Single Output	10 pcs
	Dual Output	9 pcs
	/W Version	1 pc
Emissions	CE	EN 55022: 2006 + A1: 2007 / Class B
	EMC	EN 55024:1998 + A1:2001 + A2:2003
	Harmonics	EN 61000-3-2:2006 / Class A
	Flicker	EN 61000-3-3:1995 + A1:2001 +A2:2005
Immunity	ESD	IEC 61000-4-2 / Criterion B
	RS	IEC 61000-4-3 / Criterion A
	EFT	IEC 61000-4-4 / Criterion B
	Surge	IEC 61000-4-5 / Criterion B
	CS	IEC 61000-4-6 / Criterion A
	PMF	IEC 61000-4-8 / Criterion A
	Voltage Variations	IEC 61000-4-11 / Criteria B + C
MTBF (+25°C)	using MIL-HDBK-217F	>400 x 10 ³ hours
	(+65°C)	>200 x 10 ³ hours
Certifications:		
UL General Safety	Report: E224736	UL-60950-1, 2nd Edition
cUL	Report: E224736	C22.2 No. 60950-1-07, 2nd Edition
EN General Safety	Report: SPCLVD1211033-1	EN-60950-1:2006 + A12:2011
CE		EN55022 Class B

Notes:

Note1: Measured @ 230VAC / 50Hz / Ta=25°C with constant resistant mode at full load.

Note2: If used @ 115VAC / 60Hz with full load, max. capacitive load is less, please contact RECOM for detailed information.

Single Output

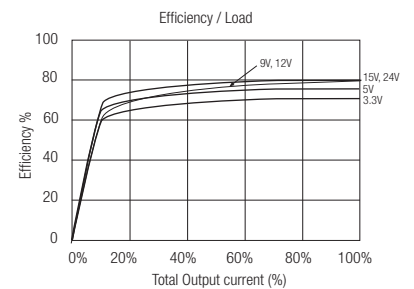

Dual Output

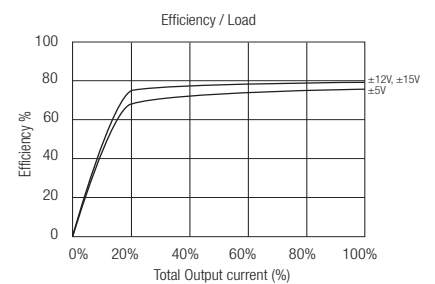

Input Voltage Derating Graph

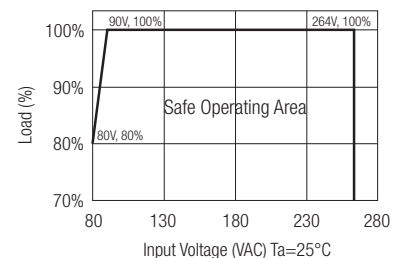

Package Style and Pinning

PCB Mounting Version (Standard)

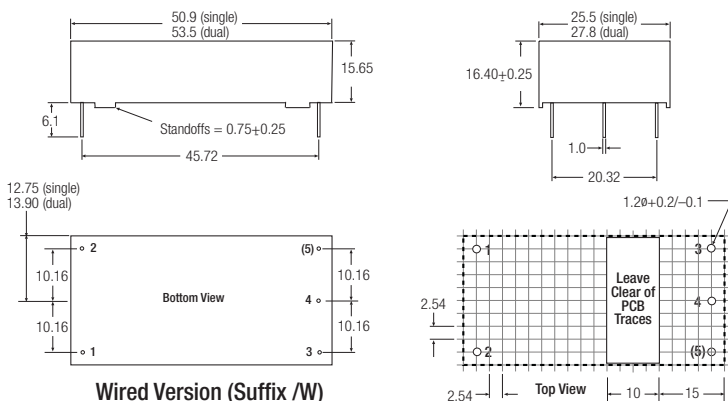

Pin Connections

Pin #	Single Out	Dual Out
1	VAC in (N)	VAC in (N)
2	VAC in (L)	VAC in (L)
3	+VDC out	+VDC out
4	-VDC out	Com
5	No Pin	-VDC out
Tolerance	± 0.5 mm	

Wire Connections

Wire	AWG#22	Single Out	Dual Out
Blue	1015	VAC in (N)	VAC in (N)
Brown	1015	VAC in (L)	VAC in (L)
Red	1007	+VDC out	+VDC out
Black	1007	-VDC out	Com
Orange	1007		-VDC out

Recommended Footprint Details

The product information and specifications are subject to change without prior notice. All products are designed for non-safety critical commercial and industrial applications. The Buyer agrees to implement safeguards that anticipate the consequences of any failures that might cause harm, loss of life and/or damage property.

Features

Regulated Converters

- Compact AC-DC Power Supply
- 10 Watt PCB Mount Package
- Universal Input Voltage Range
- 3000VAC Isolation
- Low Output Ripple and Noise
- Short Circuit Protected
- UL Certified, CE Marked

Description

Compact UL certified switching AC/DC power module for PCB, screw-terminal connection or DIN-rail mounting.

Selection Guide

Part Number	Input Range (VAC)	Output Voltage (VDC)	Output Current (mA)	Efficiency (%)	Max. Capacitive Load
RAC10-3.3SA	90-264	3.3	3000	65	70000µF
RAC10-05SA	90-264	5	2000	71	35000µF
RAC10-12SA	90-264	12	833	76	11000µF
RAC10-15SA	90-264	15	666	75	7000µF
RAC10-24SA	90-264	24	426	76	2300µF
RAC10-05DA	90-264	±5	±800	73	±22000µF
RAC10-12DA	90-264	±12	±380	75	±3000µF
RAC10-15DA	90-264	±15	±300	74	±2000µF

*add suffix "-E" for extended temperature range, e.g. RAC10-05SA-E

*add suffix "-ST" for screw terminal module e.g. RAC10-05SA-ST, RAC010-05DA-E-ST

Specifications (typical at 25°C and after warm up time unless otherwise specified)

Input Voltage Range	90-264VAC or 120-370VDC	
Rated Power	10 Watts max.	
Input Frequency Range (for AC Input)	47-440Hz	
Input Current (full load)	115VAC/230VAC	200mA / 130mA max.
No Load Power Consumption	115VAC/230VAC	1.65W max.
Inrush Current (<2ms)	115VAC	10A max. (-E = 23A max.)
	230VAC	20A max. (-E = 46A max.)
Leakage Current	0.75mA max.	
Output Voltage Accuracy (Full load)	±2%	
Line Voltage Regulation (low line, high line at full load)	±0.3% typ.	
Load Voltage Regulation (5% to 100% full load)	±0.5% typ.	
Output Ripple and Noise (20MHz limited)	Noise	0.5% Vout + 50mVp-p max.
	Ripple	<0.2% Vout + 40mVp-p max.
Operating Frequency	100kHz typ.	
Efficiency at Full Load	see table	
RMS Isolation Voltage (input to output)	3kVAC / 1minute	
Temperature Coefficient	±0.02%/°C typ.	
Isolation Resistance	100 MΩ min.	
Short Circuit Protection	Hiccup, Automatic Restart	
Operating Temperature Range	Standard	-25°C to +70°C
(free air convection, with derating)	Suffix -E	-40°C to +70°C
Storage Temperature Range	-40°C to +85°C	
Humidity	95% RH max.	
Case Material	Epoxy with Fibreglass (UL94V-0)	
Package Weight	92g	
Packing Quantity	5 pcs (-ST Version: 1 pc)	
EMC	EN 55022 Class B / EN 50082-1	
MTBF (+25°C)	using MIL-HDBK-217F	250 x 10 ³ hours

POWERLINE

AC/DC-Converter

with 3 year Warranty

RECOM

10 Watt Single/Dual Output



UL-60950-1 Certified

RAC10-A

Derating Graph (Ambient Temperature)

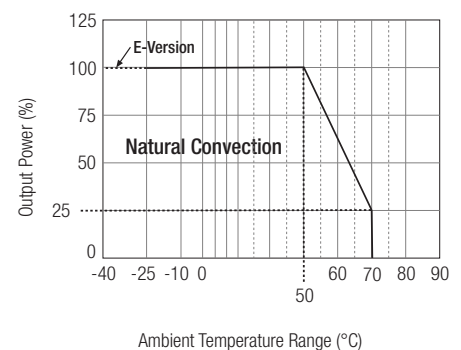

Refer to Application Notes

POWERLINE

AC/DC-Converter

RAC10-S_DA Series

Screw Terminal Module Option (suffix -ST)

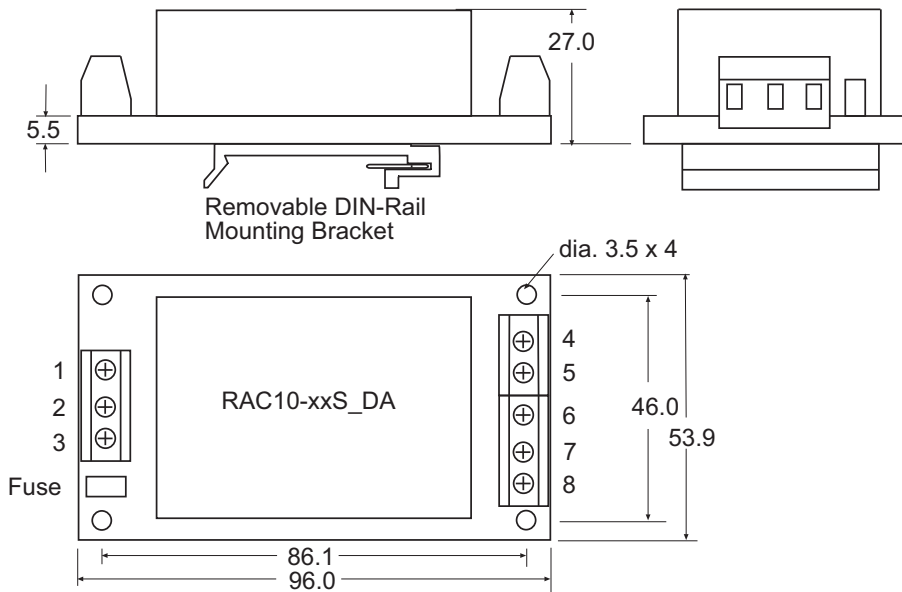

Pin Connections

Pin #	Single Out	Dual Out
1	FG	FG
2	VAC in (N)	VAC in (N)
3	VAC in (L)	VAC in (L)
4	NC	NC
5	-VDC out	-VDC out
6	NC	Com
7	+VDC out	+VDC out
8	NC	NC

NC = No Connection

Standard Package Style and Pinning

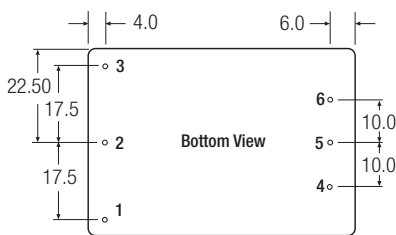
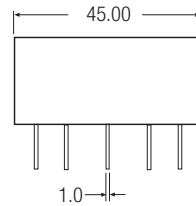
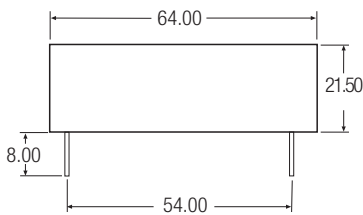

Pin Connections-

Pin #	Single Out	Dual Out
1	FG	FG
2	VAC in (N)	VAC in (N)
3	VAC in (L)	VAC in (L)
4	-VDC out	-VDC out
5	No Pin	Com
6	+VDC out	+VDC out

XX.X ± 0.5 mm
XX.XX ± 0.25 mm

RAC10-A

Standard Application Circuit

Suggested fuse rating
2A Slow Blow

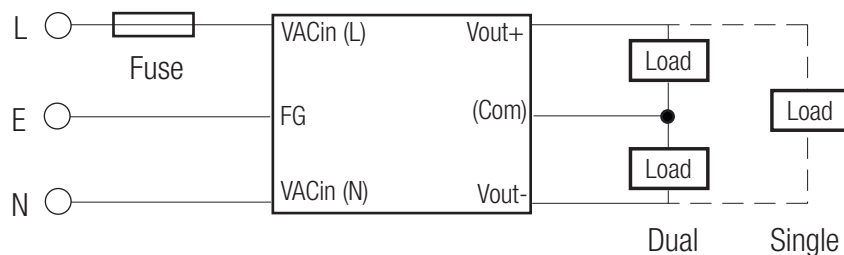

The product information and specifications are subject to change without prior notice. All products are designed for non-safety critical commercial and industrial applications. The Buyer agrees to implement safeguards that anticipate the consequences of any failures that might cause harm, loss of life and/or damage property.

Features

Regulated Converters

- Compact AC-DC Power Supply
- 10 Watt PCB Mount Package
- Universal Input Voltage Range
- 3000VAC Isolation
- Low Output Ripple and Noise
- Short Circuit Protected
- UL Certified, CE Marked

Description

Compact UL certified switching AC/DC power module for PCB, screw-terminal connection or DIN-rail mounting. Pin compatible with RAC5-xxSB models.

Selection Guide

Part Number	Input Range (VAC)	Output Voltage (VDC)	Output Current (mA)	Efficiency typ. (%)	Max. Capacitive Load
RAC10-3.3SB	90-264	3.3	2500	72	75000µF
RAC10-05SB	90-264	5	2000	75	40000µF
RAC10-12SB	90-264	12	833	77	8500µF
RAC10-15SB	90-264	15	667	77	3500µF
RAC10-24SB	90-264	24	417	77	1200µF

*add suffix "-E" for extended temperature range, e.g. RAC10-05SB-E

*add suffix "-ST" for screw terminal module e.g. RAC10-05SB-ST, RAC10-05SB-E-ST

Specifications (typical at 25°C and after warm up time unless otherwise specified)

Input Voltage Range	90-264VAC or 120-370VDC	
Rated Power	10 Watts max.	
Input Frequency Range (for AC Input)	47-440Hz	
Input Current (full load)	115VAC/230VAC	220mA/ 150mA max.
No Load Power Consumption	230VAC	490mW max.
Inrush Current (<2ms)	115VAC	10A max. (-E = 23A max.)
	230VAC	20A max. (-E = 46A max.)
Leakage Current	0.25mA max.	
Output Voltage Accuracy (Full load)	±2%	
Line Voltage Regulation (low line, high line at full load)	±0.3% typ.	
Load Voltage Regulation (5% to 100% full load)	±0.5% typ.	
Output Ripple and Noise (20MHz limited)	Noise	0.5% Vout + 50mVp-p max.
	Ripple	<0.2% Vout + 40mVp-p max.
Operating Frequency	125kHz typ.	
Efficiency at Full Load	see table	
RMS Isolation Voltage (input to output)	3kVAC / 1 minute	
Temperature Coefficient	±0.02%/°C typ.	
Isolation Resistance	100 MΩ min.	
Short Circuit Protection	Hiccup, Automatic Restart	
Operating Temperature Range	Standard	-25°C to +70°C
(free air convection, with derating)	Suffix -E	-40°C to +70°C
Storage Temperature Range	-40°C to +85°C	
Humidity	20%-85% RH	
Case Material	Epoxy with Fibreglass (UL94V-0)	
Package Weight	51g	
Packing Quantity	8 pcs (-ST Version: 1 pc)	
EMC	EN 55022 Class B / EN 55024	
MTBF (+25°C)	using MIL-HDBK-217F	330 x 10 ³ hours

POWERLINE

AC/DC-Converter

with 3 year Warranty



10 Watt Single Output

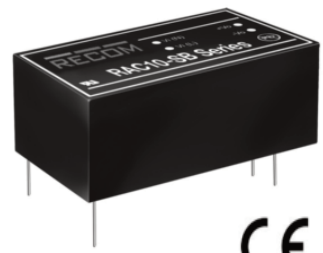

E196683

UL-60950-1 Certified

RAC10-B

Derating Graph

(Ambient Temperature)

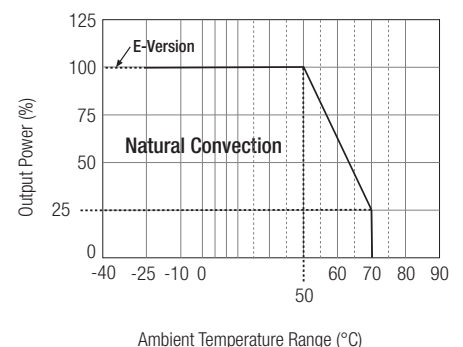

Please Read Application Notes

POWERLINE

AC/DC-Converter

RAC10-SB Series

Screw Terminal Module Option (suffix -ST)

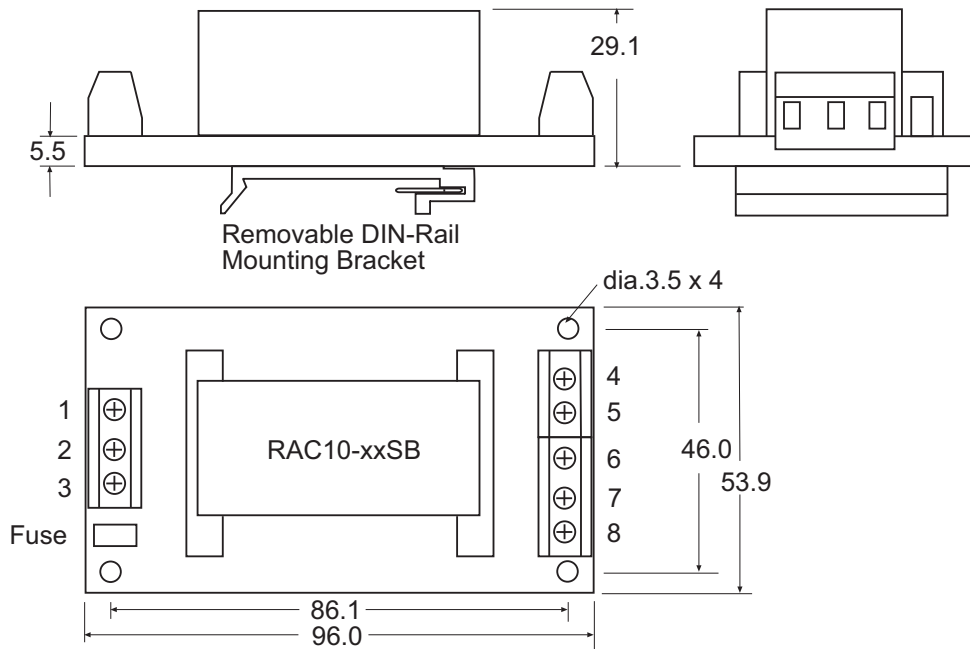

Pin Connections

Pin #	Single Out
1	NC
2	VAC in (N)
3	VAC in (L)
4	NC
5	+VDC out
6	-VDC out
7	NC
8	NC

NC = No Connection

Standard Package Style and Pinning

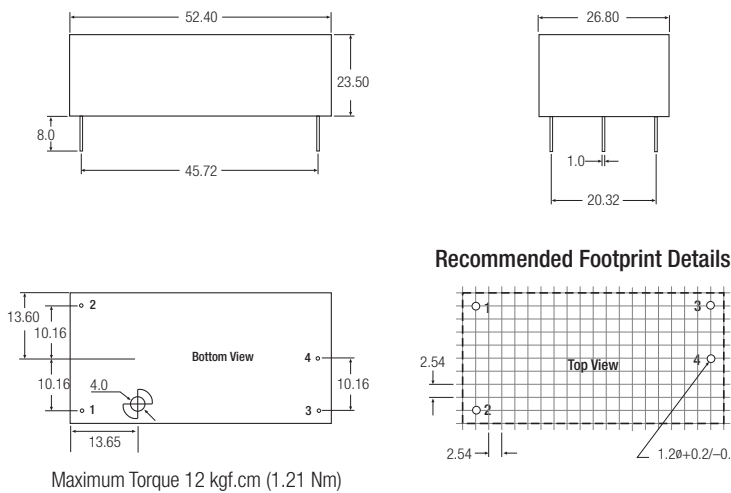

Pin Connections

Pin #	Single Out
1	VAC in (N)
2	VAC in (L)
3	+VDC out
4	-VDC out

XX.X ± 0.5 mm
XX.XX ± 0.25 mm

Standard Application Circuit

Suggested fuse rating
2A Slow Blow

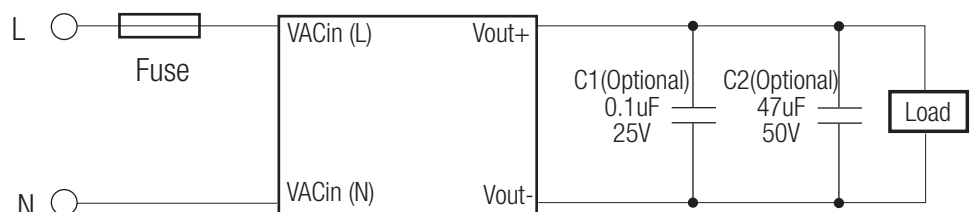

The product information and specifications are subject to change without prior notice. All products are designed for non-safety critical commercial and industrial applications. The Buyer agrees to implement safeguards that anticipate the consequences of any failures that might cause harm, loss of life and/or damage property.

Features

Regulated Converters

- Very Compact Low AC/DC Power Supply
- High Efficiency
- Single & Dual Output Options
- Continuous Short Circuit Protection
- Isolated Output 3.75kVAC/1 min
- EN55022 Class B Compliant
- High Operating Temperature
- Low Standby Power Consumption

POWERLINE

AC/DC-Converter
with 3 year Warranty



10 Watt Single / Dual Output



CE
E224736



EN60950-1 Certified
UL60950-1 Certified
CE marked

RAC10-C/277

Derating-Graph (Ambient Temperature)

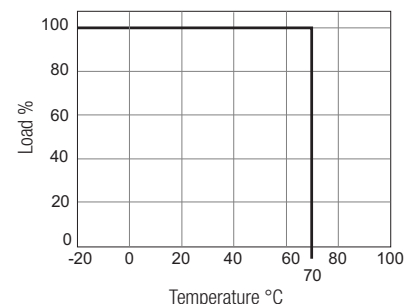

Selection Guide

Part Number	Input Range (VAC)	Output Voltage (VDC)	Output Current (mA)	Efficiency (typ.) (%)	Max. Capacitive Load (µF) ⁽¹⁺²⁾
RAC10-3.3SC/277	80-305	3.3	2500	75	50000
RAC10-05SC/277	80-305	5	2000	78	36000
RAC10-12SC/277	80-305	12	840	80	8600
RAC10-15SC/277	80-305	15	670	78	6000
RAC10-24SC/277	80-305	24	420	80	2700
RAC10-05DC/277	80-305	±5	±1000	77	±21000
RAC10-12DC/277	80-305	±12	±420	79	±3700
RAC10-15DC/277	80-305	±15	±340	79	±2900

Specifications (measured at TA 25°C, full load after warm-up)

Input Voltage Range (with Derating)	80-305VAC or 113-430VDC	
Rated Power	10 Watts	
Input Frequency Range (for AC Input)	47-63Hz	
Input Current (full load)	115VAC	250mA typ.
	230VAC	160mA typ.
No Load Power Consumption	230VAC	300mW max.
Inrush Current (cold Start-Up)	115VAC	15A max.
	230VAC	30A max.
Leakage Current	250VAC/50Hz	0.25mA max.
External Fuse Recommended	1.5A slow blow type	
Output Voltage Accuracy	3.3V	±3% typ.
	all others	±2% typ.
Line Voltage Regulation	(low line, high line at full load)	±0.3% typ.
Load Voltage Regulation	3.3V, 5V	-1.5% typ.
(0 -100% Load)	12V	±1% typ.
	all others	±0.5% typ.
Minimum Load	0%	
Output Ripple and Noise	3.3V / 5V	50mVp-p typ.
(with 0.1µF across outputs	12V / 15V / 24V	125mVp-p typ.
@20mHz bandwidth)	±5	200mVp-p typ.
	±12	125mVp-p typ.
	±15	200mVp-p typ.
Operating Frequency	100kHz	
Hold-up time	230VAC/50Hz	60ms min.
Isolation Voltage (input to output)	3.75kVAC / 1minute	
Short Circuit Protection	Hiccup, Automatic Restart	

continued on next page

Refer to Application Notes

Specifications (measured at TA 25°C, full load after warm-up)

Output Overvoltage Protection		Latch off
Overcurrent Protection		Automatic Recovery
Operating Temperature Range	(free air convection, with derating)	-20°C to +70°C
Storage Temperature Range		-40°C to +75°C
Humidity		95% RH max.
Case Material		Epoxy with Fibreglass (UL94V-0)
Dimension (L x W x H)		52.4 x 27.4 x 23.5mm
Package Weight		62g±5g
EMC	EMI	EN 55022 Class B
	EMS	EN 55024
Certifications	UL General Safety (Report: E224736)	UL60950-1
	EMC (Report: T121026N02-E)	EN55022, EN55024
MTBF (+25°C)	using MIL-HDBK-217F	320 x 10 ³ hours
	(+70°C)	using MIL-HDBK-217F

Input Voltage vs Load

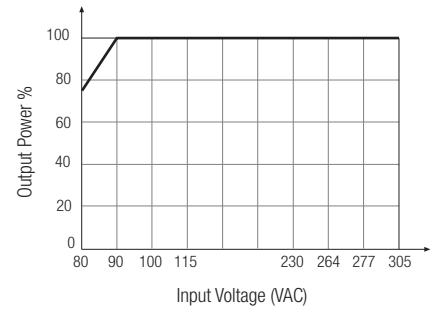

Notes:

Note1: Measured @ 230VAC / 50Hz / Ta=25°C with constant resistant mode at full load.

Note2: If used @ 115VAC / 60Hz with full load, max. capacitive load is less, please contact RECOM for detailed information.

Characteristics (measured @ 115/230VAC, 50/60Hz after warm up)

RAC10-xxSC/277

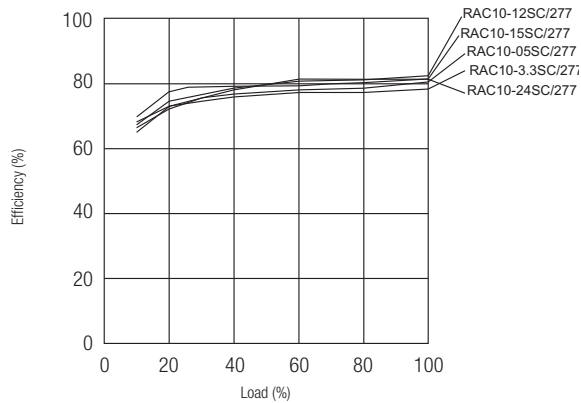

RAC10-xxDC/277

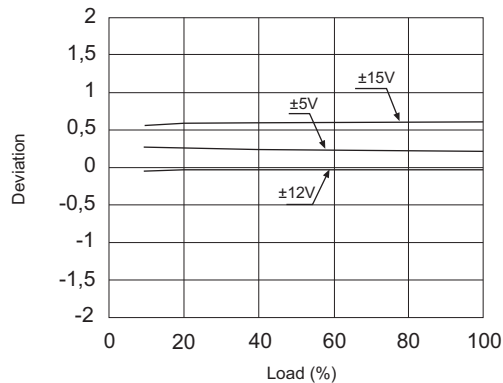
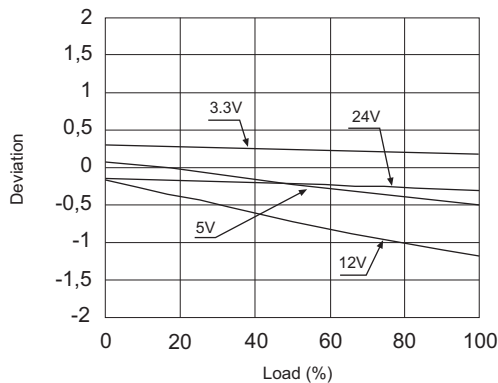
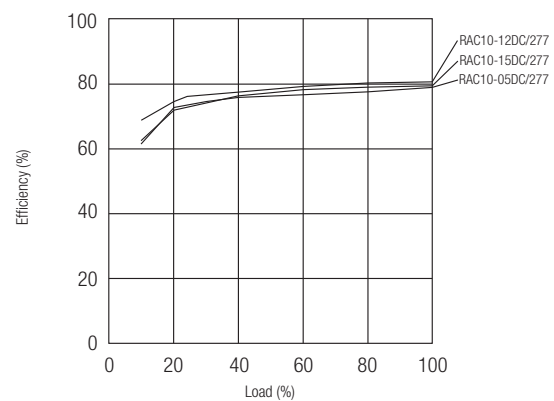

Application Notes

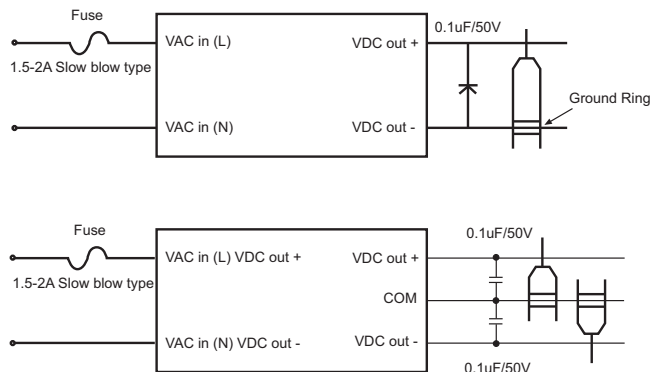

1. Recommended external input fuse 1.5A / slow blow type.
2. Do not use scope ground lead to measure the output ripple & noise.

Standard Application Circuit

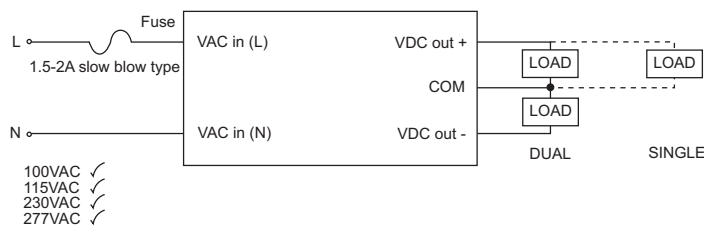

Standard Package Style and Pinning

RAC10-xxSC/277

RAC10/277

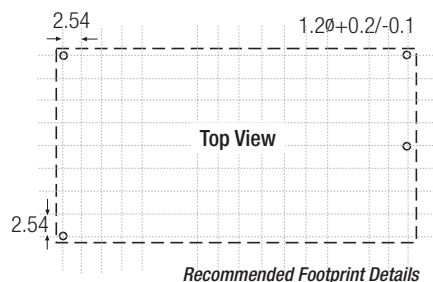
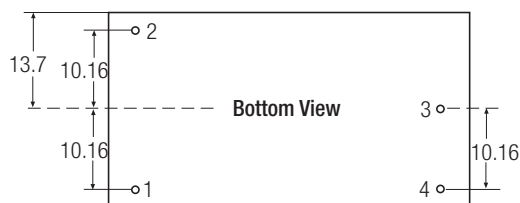
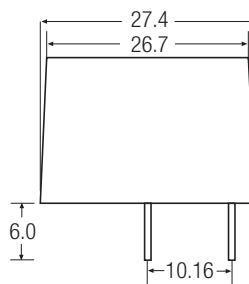
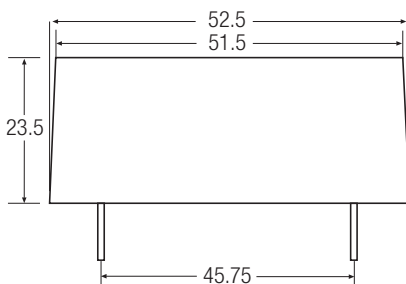

Pin Connections-

Pin #	Single Out
1	VAC in (N)
2	VAC in (L)
3	-VDC out
4	+VDC out

XX.X ± 0.5 mm
XX.XX ± 0.25 mm

Recommended Footprint Details

POWERLINE

AC/DC-Converter

RAC10-xxS_DC /277 Series

Standard Package Style and Pinning

RAC10-xxDC/277

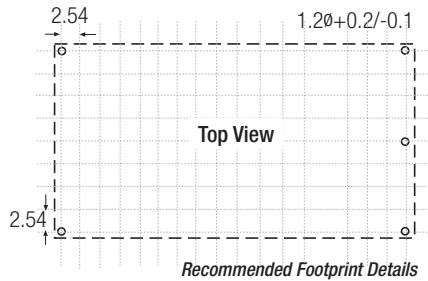
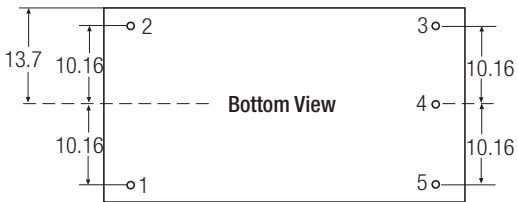
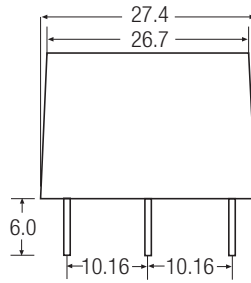
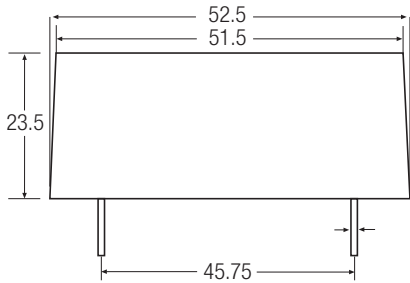

Recommended Footprint Details

Pin Connections-

Pin #	Single Out
1	VAC in (N)
2	VAC in (L)
3	-VDC out
4	COM
5	+VDC out

XX.X ± 0.5 mm
XX.XX ± 0.25 mm

The product information and specifications are subject to change without prior notice. All products are designed for non-safety critical commercial and industrial applications. The Buyer agrees to implement safeguards that anticipate the consequences of any failures that might cause harm, loss of life and/or damage property.

Features

Regulated Converters

- Compact AC-DC Power Supply
- 15 Watt PCB Mount Package
- Universal Input Voltage Range
- 3000VAC Isolation
- Low Output Ripple and Noise
- Short Circuit Protected
- UL Certified, CE Marked

Description

Compact UL certified switching AC/DC power module for PCB, screw-terminal connection or DIN-rail mounting.

Selection Guide

Part Number	Input Range (VAC)	Output Voltage (VDC)	Output Current (mA)	Efficiency (%)	Max. Capacitive Load
RAC15-05SA	90-264	5	3000	74	31000µF
RAC15-12SA	90-264	12	1250	79	4500µF
RAC15-15SA	90-264	15	1000	78	2700µF
RAC15-24SA	90-264	24	625	80	900µF
RAC15-05DA	90-264	±5	±1500	76	±13500µF
RAC15-12DA	90-264	±12	±650	79	±2700µF
RAC15-15DA	90-264	±15	±500	77	±1400µF
RAC15-0512TA	90-264	5/±12	2000/±200	73	14000/±900µF
RAC15-0515TA	90-264	5/±15	2000/±150	73	14000/±680µF

*add suffix "-E" for extended temperature range, e.g. RAC15-05SA-E

*add suffix "-ST" for screw terminal module e.g. RAC15-05DA-ST, RAC10-0512TA-E-ST

Specifications (typical at 25°C and after warm up time unless otherwise specified)

Input Voltage Range	90-264VAC or 120-370VDC	
Rated Power	15 Watts max.	
Input Frequency Range (for AC Input)	47-440Hz	
Input Current (full load)	115VAC/230VAC	310mA / 170mA max.
No Load Power Consumption	115VAC/230VAC	1.37W max.
Inrush Current (<2ms)	115VAC	10A max. (-E = 23A max.)
	230VAC	20A max. (-E = 46A max.)
Leakage Current	0.75mA max.	
Output Voltage Accuracy (Full load)	±2%	
Line Voltage Regul. (low line, high line at full load)	Single, Dual	±0.5% typ.
	Triple	±1%/±5% typ.
Load Voltage Regulation (5% to 100% full load)	Single	±0.5% typ.
	Dual	±3% typ.
	Triple	±2%/±5% typ.
Output Ripple and Noise (20MHz limited)	Noise	0.5% Vout + 50mVp-p max.
	Ripple	<0.2% Vout + 40mVp-p max.
Operating Frequency	100kHz typ.	
Efficiency at Full Load	see table	
RMS Isolation Voltage (input to output)	3kVAC / 1 minute	
Temperature Coefficient	±0.02%/°C typ.	
Isolation Resistance	100 MΩ max.	
Short Circuit Protection	Hiccup, Automatic Restart	
Operating Temperature Range	Standard	-25°C to +70°C
(free air convection, with derating)	Suffix -E	-40°C to +70°C
Storage Temperature Range	-40°C to +85°C	
Humidity	95% RH max.	
Case Material	Epoxy with Fibreglass (UL94V-0)	
Package Weight	114g	
Packing Quantity	3 pcs (-ST Version: 1 pc)	
EMC	EN 55022 Class B / EN 55024	
MTBF (+25°C)	using MIL-HDBK-217F	200 x 10 ³ hours

POWERLINE

AC/DC-Converter

with 3 year Warranty

RECOM

15 Watt Single/Dual & Triple Output



UL-60950-1 Certified

RAC15-A

Derating Graph (Ambient Temperature)

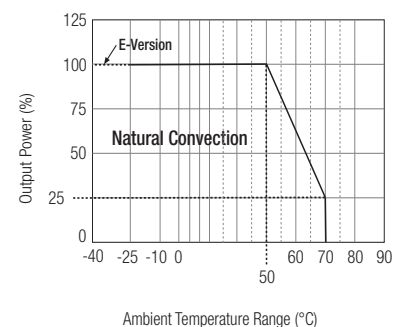

Refer to Application Notes

POWERLINE

AC/DC-Converter

RAC15-S_D_TA Series

Screw Terminal Module Option (suffix -ST)

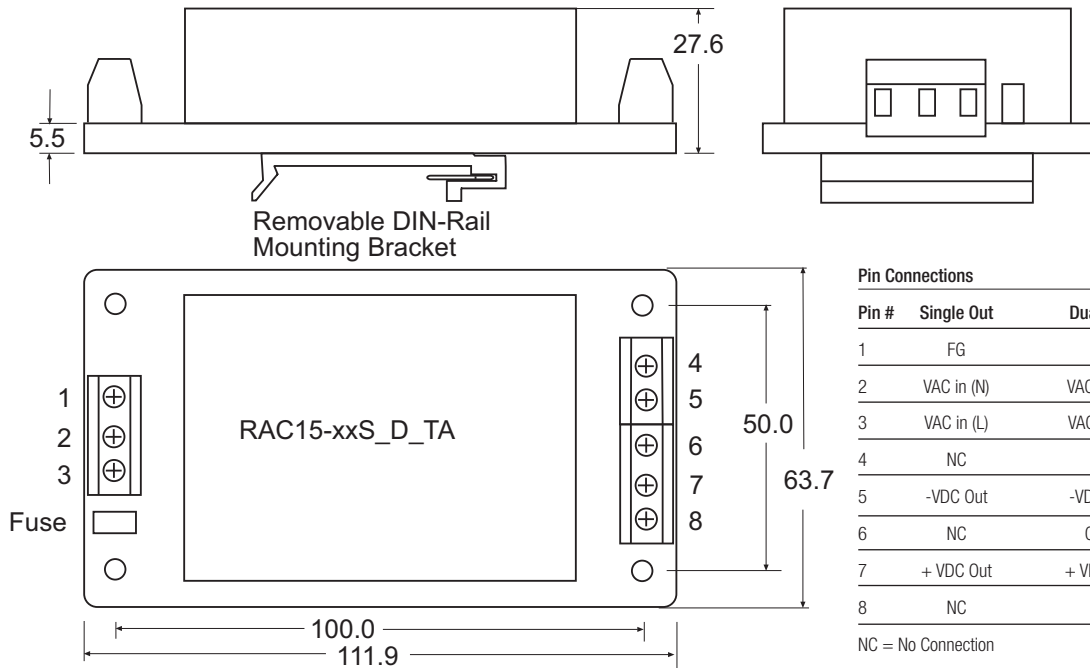

Standard Package Style and Pinning

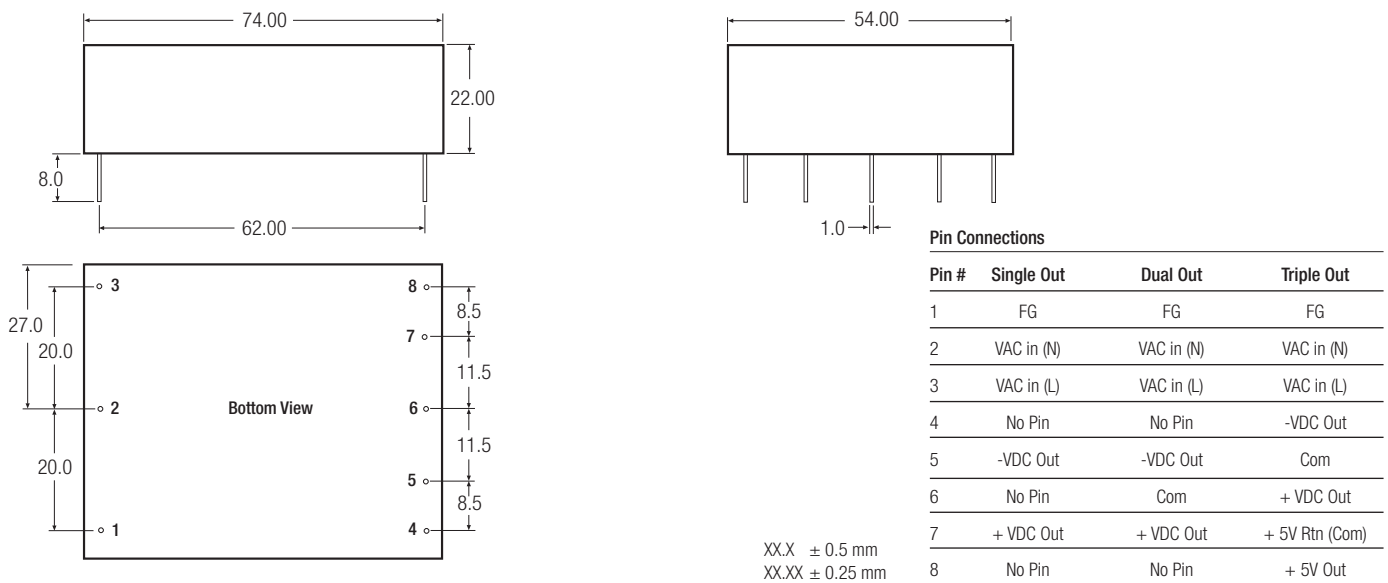

Standard Application Circuit

Suggested fuse rating

2A Slow Blow

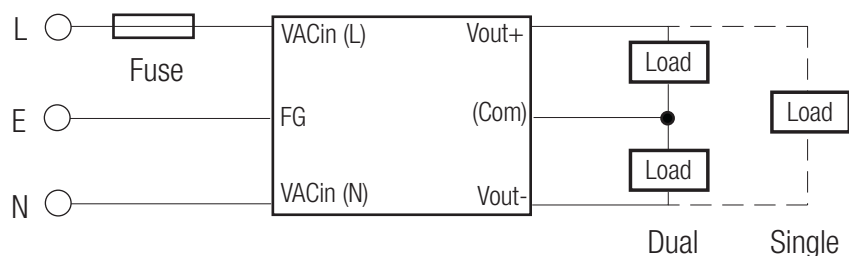

The product information and specifications are subject to change without prior notice. All products are designed for non-safety critical commercial and industrial applications. The Buyer agrees to implement safeguards that anticipate the consequences of any failures that might cause harm, loss of life and/or damage property.

Features

Regulated Converters

- Compact AC-DC Power Supply
- 20 Watt PCB Mount Package
- Universal Input Voltage Range
- 3000VAC Isolation
- Low Output Ripple and Noise
- Short Circuit Protected
- High Efficiency
- UL Certified, CE Marked

Description

Compact universal input voltage switching power module for PCB or DIN-rail mounting available with single, dual or triple output voltages

Selection Guide

Part Number	Input Range (VAC)	Output Voltage (VDC)	Output Current (mA)	Efficiency (%)	Capacitive Load (max)
RAC20-3.3SA	90-264	3.3	4500	75	25000µF
RAC20-05SA	90-264	5	4000	79	13000µF
RAC20-09SA	90-264	9	2230	82	1100µF
RAC20-12SA	90-264	12	1670	83	920µF
RAC20-15SA	90-264	15	1340	83	820µF
RAC20-24SA	90-264	24	840	84	600µF
RAC20-05DA	90-264	±5	±2000	79	±4300µF
RAC20-12DA	90-264	±12	±833	82	±560µF
RAC20-15DA	90-264	±15	±677	82	±220µF
RAC20-0512TA	90-264	5/±12	+2800/±250	81	3500/±200µF
RAC20-0515TA	90-264	5/±15	+2800/±200	81	3500/±150µF

*add suffix "-ST" for screw terminal module e.g. RAC20-05SA-ST, RAC20-05DA-ST, RAC20-0512TA-ST

Specifications (typical at 25°C and after warm up time unless otherwise specified)

Input Voltage Range	90-264VAC or 100-375VDC	
Rated Power	20 Watts max	
Input Frequency Range (for AC Input)	47-440Hz	
Input Current (full load)	115VAC/230VAC	400mA/ 230mA max.
No Load Power Consumption	115VAC/230VAC	470mW max.
Inrush Current (<2ms)	115VAC/230VAC	30A/ 50A max.
Leakage Current	0.25mA max	
Output Voltage Accuracy (Full load)	±2% max	
Line Voltage Regulation (low line, high line at full load)	- Single /Dual Output	±0.5% max
	- Triple Output	±1%/ ±5% max
Load Voltage Regulation (10% to 100% symmetric load)	- Single	±1% max
	- Dual	±3% max
	- Triple	±2% /±5% max
Output Ripple and Noise ⁽¹⁾	Noise	<0.9% Vout + 50mVp-p max.
	Ripple	<0.2% Vout + 40mVp-p max.
Minimum Load	Single/Dual = 0%, Triple = 10% main /20% auxilliary	
Operating Frequency	100kHz typ	
RMS Isolation Voltage (input to output)	3kVAC / 1 minute	
Temperature Coefficient	±0.02%/°C typ	
Over-Current Protection	105% typ	
Short Circuit Protection	Continuous, Automatic Restart	
Over-Voltage Protection	Zener Diode Clamp	
Operating Temperature Range (free air convection, with derating)	-25°C to +70°C	
Storage Temperature Range	-40°C to +85°C	

continued on next page

POWERLINE

AC/DC-Converter

with 3 year Warranty

RECOM

20 Watt Single/Dual & Triple Output



UL-60950-1 Certified

RAC20-A

Derating Graph (Ambient Temperature)

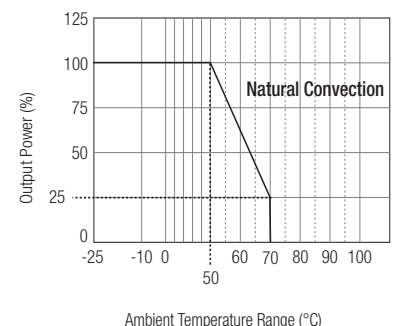

Refer to Application Notes

Specifications (typical at 25°C and after warm up time unless otherwise specified)

Humidity	95% RH max.
Case Material	Epoxy with Fibreglass (UL94V-0)
Package Weight	110g
Packing Quantity	3 pcs (-ST Version: 1 pc)
EMC	EN 55022 Class B / EN 55024
MTBF (+25°C)	using MIL-HDBK-217F >200 x 10 ³ hours

Notes:

Note 1: Ripple & Noise measured with 20MHz BW probe and 0.1µF + 47µF capacitors in parallel across the outputs.

Note 2: Suggested input fuse rating 2A Slow Blow

Screw Terminal Module Option (suffix -ST)

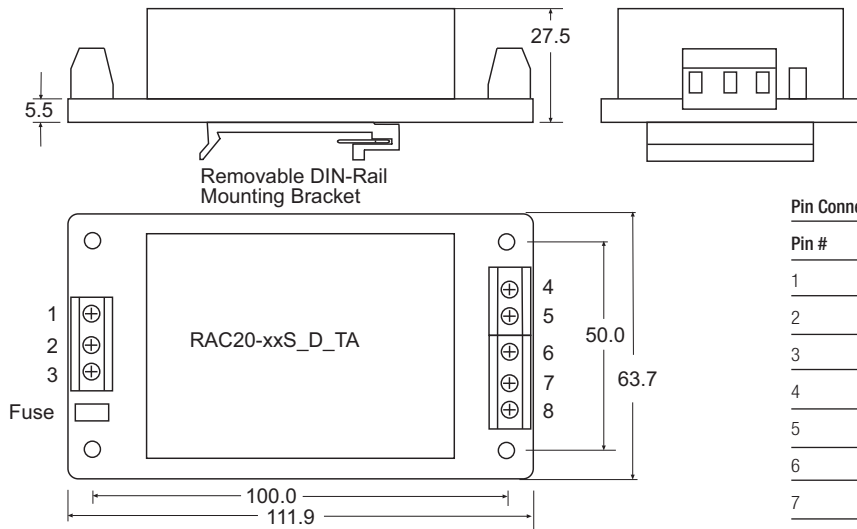

Pin Connections

Pin #	Single Out	Dual Out	Triple Out
1	FG	FG	FG
2	VAC in (N)	VAC in (N)	VAC in (N)
3	VAC in (L)	VAC in (L)	VAC in (L)
4	NC	NC	-VDC out
5	-VDC Out	-VDC Out	Com
6	NC	Com	-VDC out
7	+VDC out	+VDC out	+5V Rtn
8	NC	NC	+5Vout

NC = No Connection

Package Style and Pinning

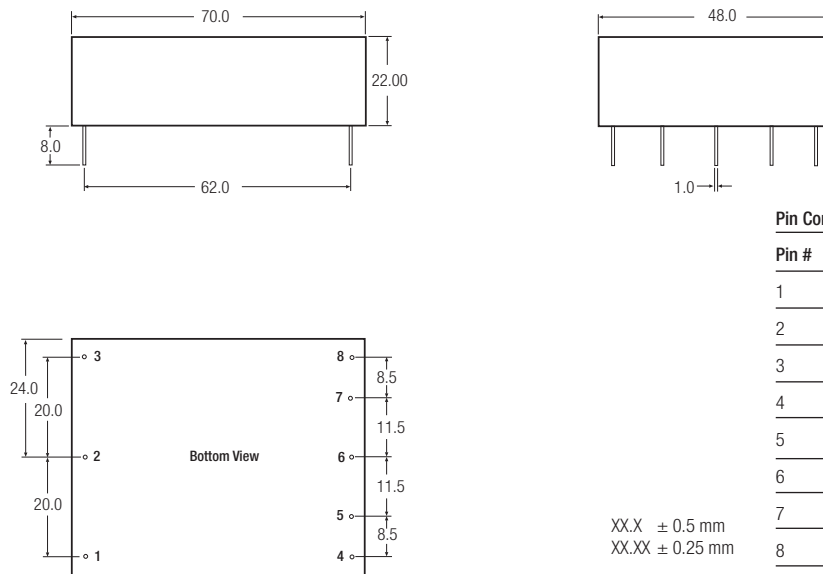

Pin Connections

Pin #	Single Out	Dual Out	Triple Out
1	FG	FG	FG
2	VAC in (N)	VAC in (N)	VAC in (N)
3	VAC in (L)	VAC in (L)	VAC in (L)
4	No Pin	No Pin	-VDC Out
5	-VDC Out	-VDC Out	Com
6	No Pin	Com	+ VDC Out
7	+ VDC Out	+ VDC Out	+ 5V Rtn (Com)
8	No Pin	No Pin	+ 5V Out

XX.X ± 0.5 mm
XX.XX ± 0.25 mm

The product information and specifications are subject to change without prior notice. All products are designed for non-safety critical commercial and industrial applications. The Buyer agrees to implement safeguards that anticipate the consequences of any failures that might cause harm, loss of life and/or damage property.

Features

Regulated Converters

- Compact AC-DC Power Supply
- 20 Watt PCB Mount Package
- Universal Input Voltage Range
- 3000VAC Isolation
- Low Output Ripple and Noise
- Short Circuit Protected
- Low Temperature Operation
- Anti Vibration Mechanical Fixing
- CE Marked

Description

Compact switching AC/DC power module for PCB, screw-terminal connection or DIN-rail mounting. The converter is pin compatible with the RAC05-SB and RAC10-SB models. A threaded insert is provided for additional mechanical fixing.

Selection Guide

Part Number	Input Range (VAC)	Output Voltage (VDC)	Output Current (mA)	Typical Efficiency (%)	Maximum Power (W)	Max. Capacitive Load
RAC20-3.3SB	90-264	3.3	3600	74	11.9W	4500µF
RAC20-05SB	90-264	5	3600	78	18W	3500µF
RAC20-12SB	90-264	12	1660	82	20W	1800µF
RAC20-15SB	90-264	15	1330	83	20W	1500µF
RAC20-24SB	90-264	24	833	83	20W	1200µF

*add suffix "-ST" for screw terminal module e.g. RAC20-05SB-ST

Specifications (typical at 25°C and after warm up time unless otherwise specified)

Input Voltage Range	90-264VAC or 120-370VDC	
Rated Power	20 Watts max.	
Input Frequency Range (for AC Input)	47-440Hz	
Input Current (full load)	115VAC/230VAC	385mA / 250mA max.
No Load Power Consumption	115VAC/230VAC	470mW max.
Inrush Current (<2ms)	115VAC	20A max.
	230VAC	40A max.
Leakage Current	0.75mA max.	
Output Voltage Accuracy (Full load)	±2%	
Line Voltage Regulation (low line, high line at full load)	±0.5% typ.	
Load Voltage Regulation (5% to 100% full load)	±1% typ.	
Output Ripple and Noise ⁽²⁾	Ripple (3.3V, 5V)	75mVp-p max.
	Noise (3.3V, 5V)	120mVp-p max.
	Others (Ripple and Noise)	1% Vout
Operating Frequency	100 - 130kHz typ.	
Minimum Load	0%	
Isolation Voltage (input to output)	3000VAC min.	
Temperature Coefficient	±0.02%/°C typ.	
Isolation Resistance	100 MΩ min.	
Short Circuit Protection	Continuous, Automatic Restart	
Operating Temp. Range	(Natural Convection, with derating)	-40°C to +70°C
	3.3V, 5V (no derating)	-40°C to +40°C
	Others (no derating)	-40°C to +45°C
Storage Temperature Range	-40°C to +85°C	
Humidity	95% RH max.	
Case Material	Epoxy with Fibreglass (UL94V-0)	
Package Weight	59g	
Packing Quantity	5 pcs (-ST Version: 1 pc)	
EMC	designed to meet EN 55022 Class B / EN 55024	
MTBF (+25°C)	using MIL-HDBK-217F	>250 x 10 ³ hours

continued on next page

POWERLINE

AC/DC-Converter

with 3 year Warranty

RECOM

20 Watt Single Output

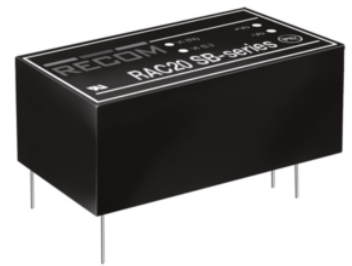

CE Marked

RAC20-B

Derating Graph (Ambient Temperature)

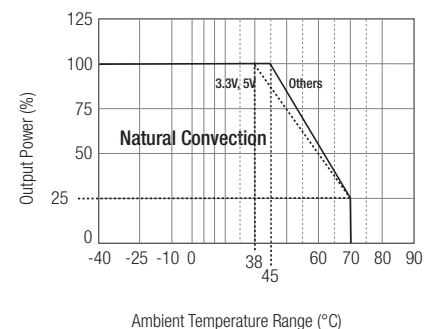

Refer to Application Notes

POWERLINE

AC/DC-Converter

RAC20-SB Series

Specifications (typical at 25°C and after warm up time unless otherwise specified)

Notes:

Note 1: Ripple & Noise measured with 20MHz BW probe and 0.47µF capacitor in parallel across the outputs.

Note 2: Suggested input fuse rating 2A Slow Blow

Screw Terminal Module Option (suffix -ST)

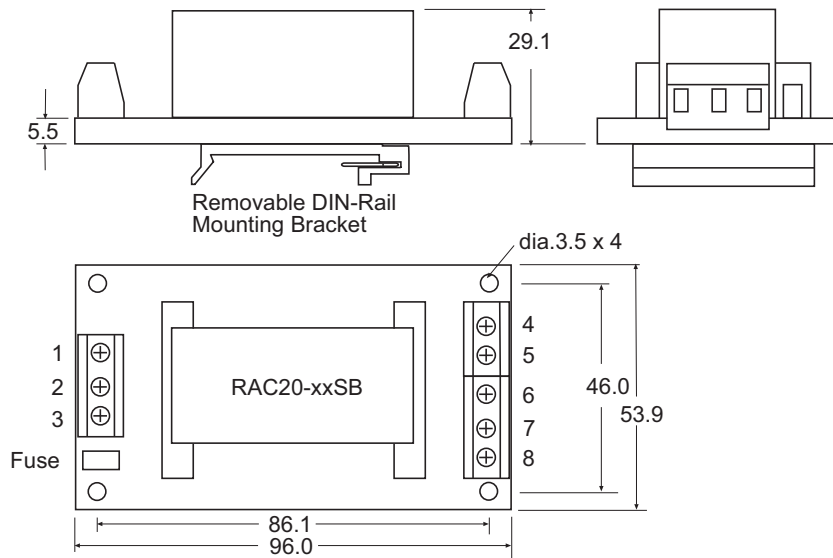

Pin Connections

Pin #	Single Out
1	NC
2	VAC in (L)
3	VAC in (N)
4	NC
5	+VDC out
6	-VDC out
7	NC
8	NC

NC = No Connection

RAC20-B

Standard Package Style and Pinning

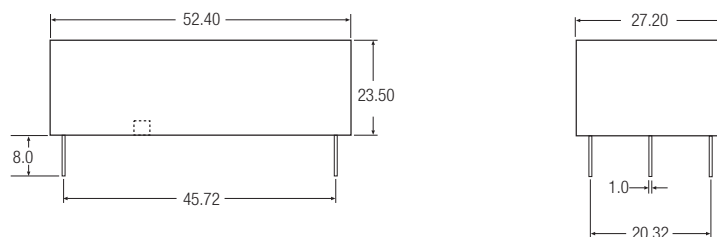

Pin Connections

Pin #	Single Out
1	VAC in (L)
2	VAC in (N)
3	+VDC out
4	-VDC out

XX.X ± 0.5 mm
XX.XX ± 0.25 mm

Recommended Footprint Details

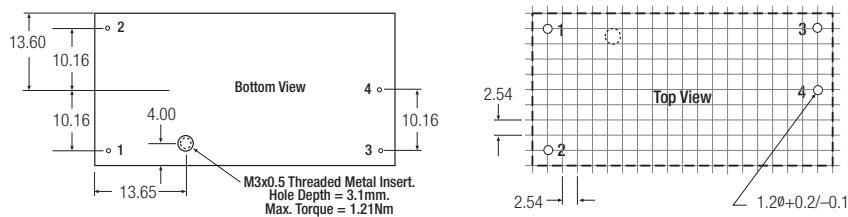

The product information and specifications are subject to change without prior notice. All products are designed for non-safety critical commercial and industrial applications. The Buyer agrees to implement safeguards that anticipate the consequences of any failures that might cause harm, loss of life and/or damage property.

Features

Regulated Converters

- AC-DC Power Supply
- 30 Watt PCB Mount Package
- Universal Input Voltage Range
- 3000VAC Isolation
- Low Output Ripple and Noise
- Short Circuit Protected
- Triple Output with Independent Outputs
- UL Certified, CE Marked

Description

Compact UL certified switching AC/DC power module for PCB, screw-terminal connection or DIN-rail mounting.

Selection Guide

Part Number	Input Range (VAC)	Output Voltage (VDC)	Output Current (mA)	Efficiency (%)	Max. Capacitive Load
RAC30-3.3SA	90-264	3.3	6000	75	80000µF
RAC30-05SA	90-264	5	6000	79	70000µF
RAC30-12SA	90-264	12	2500	82	14000µF
RAC30-15SA	90-264	15	2000	82	11000µF
RAC30-24SA	90-264	24	1250	82	5900µF
RAC30-05DA	90-264	±5	±3000	79	±50000µF
RAC30-12DA	90-264	±12	±1250	82	±14000µF
RAC30-15DA	90-264	±15	±1000	80	±10000µF
RAC30-0512DA	90-264	5/12	3000/1250	79	13200/±6400µF
RAC30-0512TA	90-264	5/±12	3000/±630	79	15000/±5400µF
RAC30-0515TA	90-264	5/±15	3000/±500	78	10000/3200µF

*add suffix "-E" for extended temperature range, e.g. RAC30-05SA-E

*add suffix "-ST" for screw terminal module e.g. RAC30-05DA-ST, RAC30-0512TA-E-ST

Specifications (typical at 25°C and after warm up time unless otherwise specified)

Input Voltage Range	90-264VAC or 120-370VDC	
Rated Power	30 Watts max.	
Input Frequency Range (for AC Input)	47-440Hz	
Input Current (full load)	115VAC/230VAC	520mA/ 320mA max.
No Load Power Consumption	115VAC/230VAC	2.58W max.
Inrush Current (<2ms)	115VAC	10A max. (-E = 23A max.)
	230VAC	20A max. (-E = 46A max.)
Leakage Current	0.75mA max.	
Output Voltage Accuracy (Full load)	±2%	
Line Voltage Regul. (low line, high line at full load) ⁽²⁾	Single, Dual	±1% typ.
	Double, Triple	±1%/±5% typ.
Load Voltage Regulation (5% to 100% full load)	Single, Dual	±1%, ±3%typ.
	Double, Triple	±2%/±6% typ.
Minimum Load	Single	3.3V: 5%/ 5V: 8%/ 12V, 15V, 24V: 2%
	Dual	±5V: 2%/ ±12V: 3%/ ±15V: 1%
	Double, Triple	20%
Output Ripple and Noise (20MHz limited)	Noise	0.5% Vout + 50mVp-p max.
	Ripple	<0.2% Vout + 40mVp-p max.
Operating Frequency	100kHz typ.	
Efficiency at Full Load	see table	
RMS Isolation Voltage (input to output)	3kVAC min.	
Temperature Coefficient	±0.02%/°C typ.	
Isolation Resistance	100 MΩ max.	
Short Circuit Protection	Continuous, Automatic restart	

continued on next page

POWERLINE

AC/DC-Converter

with 3 year Warranty

RECOM

30 Watt Single/Dual/ Double & Triple Output



UL-60950-1 Certified

RAC30-A

Derating Graph (Ambient Temperature)

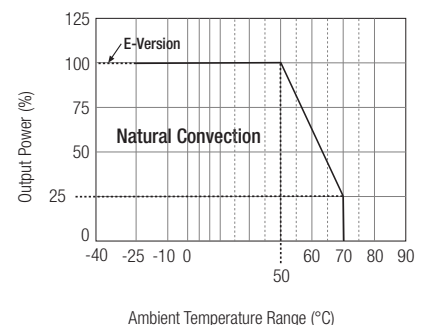

Refer to Application Notes

POWERLINE

AC/DC-Converter

RAC30-S_D_TA Series

Specifications (typical at 25°C and after warm up time unless otherwise specified)

Operating Temperature Range (free air convection, with derating)	Standard Suffix -E	-25°C to +70°C -40°C to +70°C
Storage Temperature Range		-40°C to +85°C
Humidity		95% RH max.
Case Material		Epoxy with Fibreglass (UL94V-0)
Package Weight		212g
Packing Quantity		2 pcs (-ST Version: 1 pc)
EMC		EN 55022 Class B / EN 55024
MTBF (+25°C)	using MIL-HDBK-217F	200 x 10 ³ hours

Notes:

Note 1: Suggested input fuse rating 3.15A Slow Blow

Note 2: Triple output version has +/-Vout common that is not connected to +5V Return pin internally.

Screw Terminal Module Option (suffix -ST)

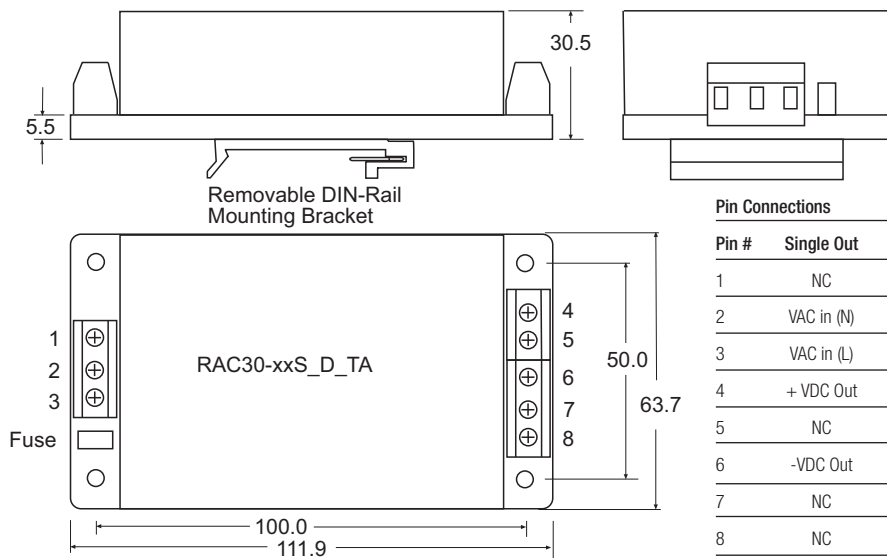

Pin Connections

Pin #	Single Out	Dual Out	0512DA	Triple Out
1	NC	NC	NC	NC
2	VAC in (N)	VAC in (N)	VAC in (N)	VAC in (N)
3	VAC in (L)	VAC in (L)	VAC in (L)	VAC in (L)
4	+ VDC Out	+VDC Out	+12V Out	+ VDC Out
5	NC	NC	+5V Out	+5V Out
6	-VDC Out	Com	+12V Rtn	Com
7	NC	NC	+5V Rtn	+5V Rtn
8	NC	-VDC Out	NC	-VDC Out

NC = No Connection

Standard Package Style and Pinning

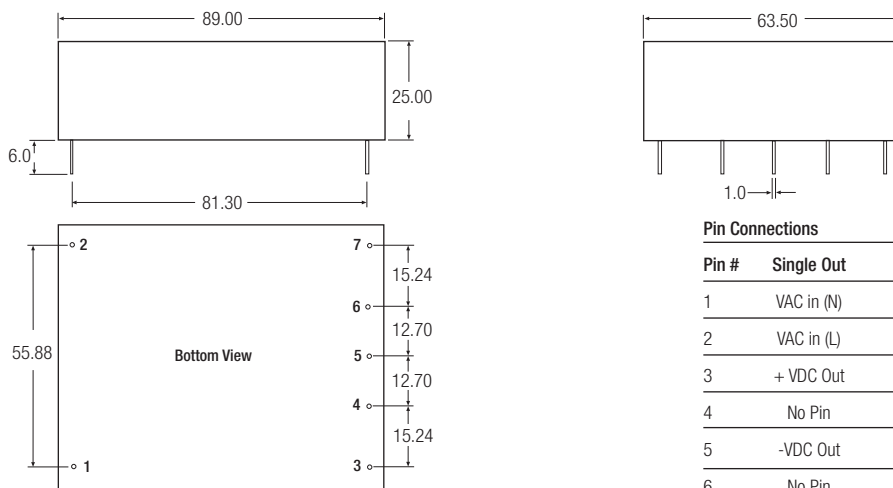

Pin Connections

Pin #	Single Out	Dual Out	0512DA	Triple Out
1	VAC in (N)	VAC in (N)	VAC in (N)	VAC in (N)
2	VAC in (L)	VAC in (L)	VAC in (L)	VAC in (L)
3	+ VDC Out	+VDC Out	+12V Out	+ VDC Out
4	No Pin	No Pin	+5V Out	+5V Out
5	-VDC Out	Com	+12V Rtn	Vout Com
6	No Pin	No Pin	+5V Rtn	+5V Rtn
7	NC	-VDC Out	No Pin	-VDC Out

XX.X ± 0.5 mm
XX.XX ± 0.25 mm

The product information and specifications are subject to change without prior notice. All products are designed for non-safety critical commercial and industrial applications. The Buyer agrees to implement safeguards that anticipate the consequences of any failures that might cause harm, loss of life and/or damage property.

Features

Regulated Converters

- Compact 40W AC-DC Power Supply
- Universal Input Voltage Range
- 3000VAC Isolation
- Low Output Ripple and Noise
- Short Circuit Protected
- Triple Output with Independent Outputs
- Suitable for Industrial Applications
- CE Marked

Description

Compact switching power module for PCB or DIN-rail mounting

Selection Guide

Part Number	Input Range (VAC)	Output Voltage (VDC)	Output Current (mA)	Efficiency (%)	Max. Capacitive Load
RAC40-05SB	90-264	5	8000	81	40000µF
RAC40-12SB	90-264	12	3333	84	8600µF
RAC40-15SB	90-264	15	2666	83	6600µF
RAC40-24SB	90-264	24	1667	83	1400µF
RAC40-05DB	90-264	±5	±4000	81	±12000µF
RAC40-12DB	90-264	±12	±1666	83	±4400µF
RAC40-15DB	90-264	±15	±1333	83	±1000µF
RAC40-0512DB	90-264	5/12	5000/1250	82	10000/470µF
RAC40-0512TB	90-264	5/±12	+5000/±600	82	10000/±780µF
RAC40-0515TB	90-264	5/±15	+5000/±500	81	10000/±900µF

*add suffix "-ST" for screw terminal module e.g. RAC40-05SB-ST, RAC40-05DB-ST, RAC40-0512TB-ST

Specifications (typical at 25°C and after warm up time unless otherwise specified)

Input Voltage Range	90-264VAC or 100-375VDC
Rated Power	40 Watts max.
Input Frequency Range (for AC Input)	47-440Hz
Input Current (full load)	115VAC/230VAC 860mA/ 460mA max.
No Load Power Consumption	115VAC/230VAC 720mW max.
Inrush Current (<2ms)	115VAC/230VAC 30A / 50A max.
Leakage Current	0.75mA max.
Holdup time	10ms min.
Output Voltage Accuracy (Full load) ⁽²⁾	Single, Dual Outputs ±2% typ. Double/Triple: Main Output ±3% typ., Secondary Output(s) ±5% typ.
Line Voltage Regulation (low line, high line at full load)	Single, Dual Outputs ±0.5% typ. Double/Triple: Main Output ±0.5% typ., Secondary Output(s) ±5% typ.
Load Voltage Regulation (10% to 100% Load)	(1% to 100% Load) Single: ±1% typ. Dual: Main Output ±1% typ., Secondary Output ±1% typ.
(10% to 100% Load)	Double: Main Output ±2% typ., Secondary Output ±6% typ.
(10% to 100% Load)	Triple: Main Output ±3% typ., Secondary Outputs ±7% typ.
Cross Regulation	Dual: Main Output ±5%, Secondary Output ±5% typ. Double: Main Output ±1% typ., Secondary Output ±7% typ. Triple: Main output ±3% typ., Secondary Outputs ±7% typ.
Output Ripple and Noise (20MHz limited, 0.1µF and 47µF across outputs)	1% Vout max.
Operating Frequency	132kHz typ.
RMS Isolation Voltage (input to output)	3kVAC / 1 minute
Temperature Coefficient	±0.01%/°C typ.
Isolation Resistance	100 MΩ min.
Short Circuit Protection	Continuous, Automatic Restart
Overcurrent Protection	105% typ.
Over Temperature Protection	100°C
Operating Temperature Range (free air convection, with derating)	-40°C to +70°C
Storage Temperature Range	-40°C to +85°C

continued on next page

POWERLINE

AC/DC-Converter

with 3 year Warranty

RECOM

40 Watt Single/Dual/ Double & Triple Output



RAC40-B

Derating Graph (Ambient Temperature)

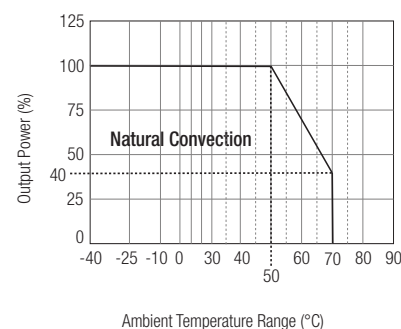

Refer to Application Notes

Specifications (typical at 25°C and after warm up time unless otherwise specified)

Humidity		95% RH
Case Material		Epoxy with Fibreglass (UL94V-0)
Package Weight		280g
suffix (-ST)		300g
Packing Quantity		2 pcs (-ST Version: 1 pc)
EMC		EN 55022 Class B, EN55024
MTBF (+25°C)	using MIL-HDBK-217F	200~400 x 10 ³ hours

Notes:

Note 1: Suggested input fuse rating 3.15A Slo Blo

Note 2: Triple output version has +/-Vout common that is not connected to +5V Return pin internally.

Screw Terminal Module Option (suffix -ST)

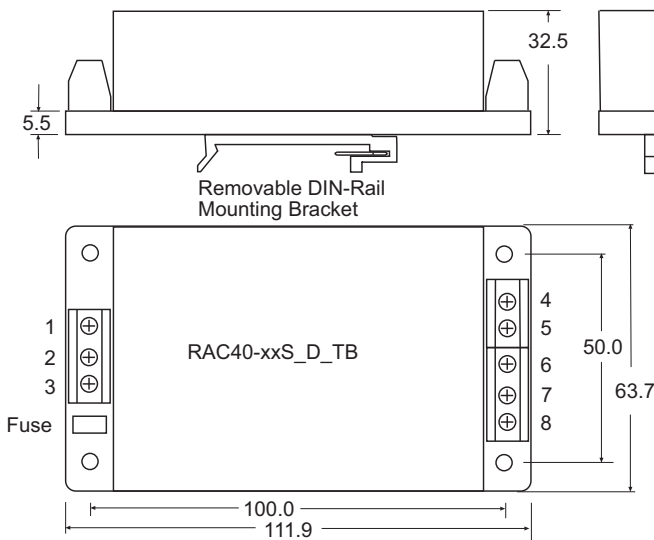

Pin Connections

Pin #	Single Out	Dual Out	Double Out	Triple Out
1	NC	NC	NC	NC
2	VAC in (L)	VAC in (L)	VAC in (L)	VAC in (L)
3	VAC in (N)	VAC in (N)	VAC in (N)	VAC in (N)
4	+VDC out	+VDC out	+12V Out	+VDC out
5	NC	NC	+5V Out	+5V Out
6	-VDC out	Com	+12V Rtn	Com
7	NC	NC	+5V Rtn	+5V Rtn
8	NC	-VDC out	NC	-VDC out

NC = No Connection

Package Style and Pinning

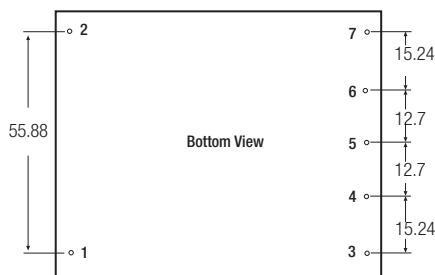
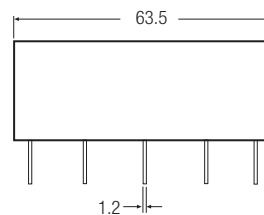
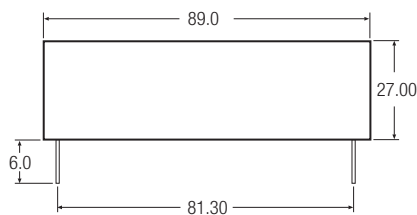

Tolerance = ± 0.5 mm

Pin Connections

Pin #	Single Out	Dual Out	Double Out	Triple Out
1	VAC in (L)	VAC in (L)	VAC in (L)	VAC in (L)
2	VAC in (N)	VAC in (N)	VAC in (N)	VAC in (N)
3	+VDC out	+VDC out	+12V Out	+VDC out
4	No Pin	No Pin	+5V Out	+5V Out
5	-VDC out	Com	+12V Rtn	Vout Com
6	No Pin	No Pin	+5V Rtn	+5V Rtn
7	NC	-VDC out	No Pin	-VDC out

The product information and specifications are subject to change without prior notice. All products are designed for non-safety critical commercial and industrial applications. The Buyer agrees to implement safeguards that anticipate the consequences of any failures that might cause harm, loss of life and/or damage property.

Features

Regulated Converters

- AC-DC Power Supply
- 60 Watt PCB Mount Package
- Universal Input Voltage Range
- 4kVAC Isolation RMS
- Low Output Ripple and Noise
- Short Circuit Protected
- Output Trim
- UL Certified, CE Marked

Description

Compact high power switching power module for PCB mounting. This switching converter has an universal AC or DC input voltage range with single high current outputs which are trimmable to compensate for any voltage drops on the output connections. Threaded inserts ensure mechanical fixing.

Selection Guide

Part Number	Input Range (VAC)	Output Voltage (VDC)	Output Current (mA)	Output Power (W)	Efficiency at 230V %	Max Capacitive Load
RAC60-05SB	85-265	5	10000	50	82	80000µF
RAC60-09SB	85-265	9	6600	60	84	28000µF
RAC60-12SB	85-265	12	5000	60	86	14000µF
RAC60-15SB	85-265	15	4000	60	86	12000µF
RAC60-24SB	85-265	24	2500	60	86	4000µF
RAC60-48SB	85-265	48	1250	60	86	950µF

Specifications (typical at 25°C and after warm up time unless otherwise specified)

Input Voltage Range	85-265VAC or 100-370VDC	
Rated Power	60 Watts max.	
Input Frequency Range (for AC Input)	47-63Hz	
Input Current (full load)	115VAC/230VAC	2A/ 1A max.
No Load Power Consumption	115VAC/230VAC	520mW max.
Inrush Current (<2mS)	115VAC/230VAC	30A/ 50A max.
Leakage Current	3.5mA max.	
Output Voltage Accuracy (Full load)	±2%	
Line Voltage Regulation (LL to HL at full load)	Single	±1% typ.
Load Voltage Regulation (5% to 100% full load)	Single	±1% typ.
Minimum Load	1%	
Output Noise (20MHz limited)	0.5%Vout + 50mVp-p max	
Output Ripple (20MHz limited)	<0.2%Vout + 40mVp-p max	
Output Trim	±10%	
Operating Frequency	100kHz typ.	
Efficiency at Full Load	see table	
RMS Isolation Voltage (input to output)	4kVAC / 1 minute	
Temperature Coefficient	±0.02%/°C typ.	
Isolation Resistance	100 MOhm max.	
Short Circuit Protection	Continuous, Hiccup, Automatic Restart	
Operating Temperature Range	free air convection, with derating	-40°C to +70°C
Storage Temperature Range	-40°C to +85°C	
Humidity	95% RH max.	
Case Material	Plastic Resin with Fibreglass (UL94V-0)	
Package Weight	310g	
Packing Quantity	1 pc	
EMC	EN 55011 Class B / EN 55022 Class B / EN 60601-1-2/ EN61000-3-2 -3 EN 55024 / EN61000-4-2 -3 -4 -5 -6 - 8 -11	
MTBF (using MIL-HDBK-217F, 25°C)	>130 x 10 ³ hours	

POWERLINE

AC/DC-Converter

with 3 year Warranty

RECOM

60 Watt Single Output



UL-60950-1 Certified

RAC60-B

Derating Graph (Ambient Temperature)

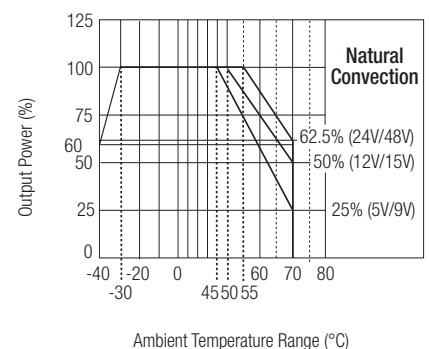

Refer to Application Notes

POWERLINE

AC/DC-Converter

RAC60-SB Series

Package Style and Pinning

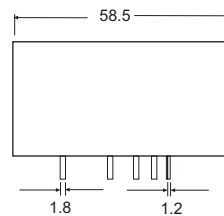
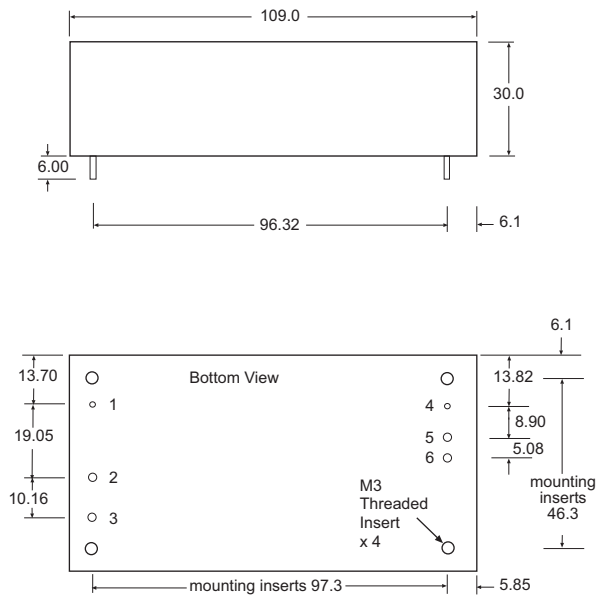

Pin Connections – Single Output

Pin #	Dia.(mm)	Function
1	1.2	FG
2	1.8	VAC in (L)
3	1.8	VAC in (N)
4	1.2	Trim
5	1.8	-VDC Out
6	1.8	+VDC Out

Tolerance ± 0.5 mm

Output Trim Adjustment

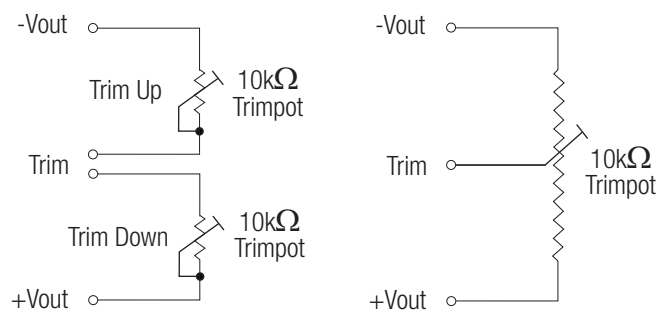

Standard Application Circuit

Suggested fuse rating
4A Slow Blow

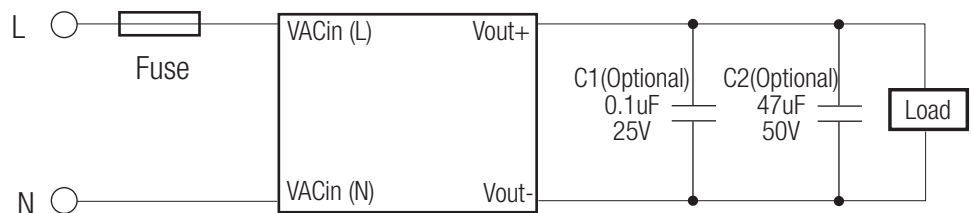

The product information and specifications are subject to change without prior notice. All products are designed for non-safety critical commercial and industrial applications. The Buyer agrees to implement safeguards that anticipate the consequences of any failures that might cause harm, loss of life and/or damage property.

POWERLINE - CONTENTS

RECOM

Powerline DC/DC Converters

8W - 60W, Single, Dual and Triple Outputs
12VDC, 24VDC and 48VDC 2:1 Inputs
24VDC and 48VDC 4:1 Inputs
Power Modules

PowerlinePlus DC/DC Converters

20W - 50W, Single and Dual Outputs
12VDC, 24VDC and 48VDC 2:1 Inputs
24VDC and 48VDC 4:1 Inputs
Built-in Heatsink and Class B Filter

Powerline AC/DC Converters

3W - 100W, Single, Dual and Triple Outputs
Universal Input Voltage
PCB Mounting and Screw Terminal Options

POWERLINE DC/DC - CONTENTS

Regulated Converters

Series	Isolation (kV)	Power (Watts)	Input Voltages (VDC)	Output Voltages (VDC)	Case Dimensions mm	Heatsink Part No.* (Power Module)	Page No.
RP08-A	1.6	8	9-18, 18-36, 36-75	3.3, 5, 12, 15 ±5, ±12, ±15	DIP24 (SMD)	N/A	P1
RP08-AW	1.6	8	9-36, 18-75	3.3, 5, 12, 15 ±5, ±12, ±15	DIP24 (SMD)	N/A	P5
RP10-E	1.6	10	9-18, 18-36, 36-75	5, 12, 15 ±5, ±12, ±15	50.8 x 25.4 x 10.2 (2" x 1")	7G-0020C	P10
RP10-EW	1.6	10	9-36, 18-75	5, 12, 15 ±5, ±12, ±15	50.8 x 25.4 x 10.2 (2" x 1")	7G-0020C	P14
RP12-A	1.6	12	9-18, 18-36, 36-75	3.3, 5, 12, 15 ±5, ±12, ±15	DIP24	N/A	P18
RP12-AW	1.6	12	9-36, 18-75	3.3, 5.1, 12, 15 ±5, ±12, ±15	DIP24	N/A	P22
RP15-B	1.6	15	9-18, 18-36, 36-75	3.3, 5.1, 12, 15 ±5, ±12, ±15	DIP24	N/A	P25
RP15-BW	1.6	15	9-18, 18-36, 36-75	3.3, 5.1, 12, 15 ±5, ±12, ±15	DIP24	N/A	P29
RP15-SOF	2.25	15	18-36, 36-75	3.3, 5, 12, 15	27.9 x 23.9 x 8.5	Open Frame SMD	P33
RP15-SOFW	2.25	15	9-36, 18-75	3.3, 5, 12, 15	27.9 x 23.9 x 8.5	Open Frame SMD	P37
RP15-A	1.6	15	9-18, 18-36, 36-75	3.3, 5, 12, 15 ±5, ±12, ±15	25.4 x 25.4 x 10.2 (1" x 1")	7G-0047C	P41
RP15-AW	1.6	15	9-36, 18-75	3.3, 5, 12, 15 ±5, ±12, ±15	25.4 x 25.4 x 10.2 (1" x 1")	7G-0047C	P45
RP15-F	1.6	15	9-18, 18-36, 36-75	3.3, 5, 12, 15 ±5, ±12, ±15	50.8 x 25.4 x 10.2 (2" x 1")	7G-0020C	P49
RP15-FW	1.6	15	9-36, 18-75	3.3, 5, 12, 15 ±5, ±12, ±15	50.8 x 25.4 x 10.2 (2" x 1")	7G-0020C	P53
RP20-A	1.6	20	9-18, 18-36, 36-75	3.3, 5, 12, 15 ±12, ±15	25.4 x 25.4 x 10.2 (1" x 1")	7G-0047C	P56
RP20-AW	1.6	20	9-36, 18-75	3.3, 5, 12, 15 ±12, ±15	25.4 x 25.4 x 10.2 (1" x 1")	7G-0047C	P60
RP20-F	1.6	20	9-18, 18-36, 36-75	3.3, 5, 12, 15 ±12, ±15	50.8 x 25.4 x 10.2 (2" x 1")	7G-0020C	P64
RP20-FW	1.6	20	9-36, 18-75	3.3, 5, 12, 15 ±5, ±12, ±15	50.8 x 25.4 x 10.2 (2" x 1")	7G-0020C	P68
RP30-E	1.6	30	9-18, 18-36, 36-75	3.3, 5, 12, 15 ±12, ±15	50.8 x 40.6 x 10.2 (2" x 1.6")	7G-0011C RPM30-E	P71 P101
RP30-EW	1.6	30	10-40, 18-75	3.3, 5, 12, 15 ±12, ±15	50.8 x 40.6 x 10.2 (2" x 1.6")	7G-0011C RPM30-EW	P75 P101
RP30-F	1.6	30	9-18, 18-36, 36-75	3.3, 5, 12, 15 ±5, ±12, ±15	50.8 x 25.4 x 10.2 (2" x 1")	7G-0020C	P79
RP30-FW	1.6	30	9-36, 18-75	3.3, 5, 12, 15 ±5, ±12, ±15	50.8 x 40.6 x 10.2 (2" x 1")	7G-0020C	P84
RP40-G	1.6	40	9-18, 18-36, 36-75	3.3, 5, 12, 15 ±12, ±15 5±12, 5±15	50.8 x 50.8 x 10.2 (2" x 2")	7G-0026C RPM40-G	P89 P101
RP40-GW	1.6	40	9-36, 18-75	3.3, 5, 12, 15 ±12, ±15	51.3 x 51.3 x 10.2 (2" x 2")	7G-0026C RPM40-GW	P93 P101
RP60-G	1.6	60	18-36, 36-75	3.3, 5, 12, 15	51.3 x 51.3 x 10.2 (2" x 2")	7G-0026C RPM60-G	P97 P101

*Heatsinks include mounting clips and double-sided adhesive pad. Add -HC to part number for pre-assembled heatsinks

Recom Power Module is a panel mounting adapter with screw terminals, built-in EMC Filter and DIN rail bracket. Refer to end of section for more details.

Features

Regulated Converters

- 2:1 Wide Input Voltage Range
- 8 Watts Regulated Output Power
- 1.6kVDC Isolation
- UL Certified
- Low Profile, 10.2 mm Height
- Over Current Protection
- Five-Sided Shield
- Standard DIP24 and SMD-Pinning
- Efficiency to 87 %

Description

The RP08-A series DC/DC converters are certified to UL 60950-1 and cUL 60950-1. This makes them ideal for all telecom and industrial applications where approved safety standards are required.

The DIP24 package is available in both pinned and SMD case styles and meets military standards for thermal shock and vibration tolerance.

Selection Guide

Part Number	Input Range VDC	Output Voltage VDC	Output Current mA	Input ⁽⁴⁾ Current mA	Efficiency ⁽⁵⁾ %	Capacitive ⁽⁶⁾ Load max.
RP08-123.3SA**	9-18	3.3	2000	724	80	3300µF
RP08-1205SA**	9-18	5	1500	801	83	1600µF
RP08-1212SA**	9-18	12	666	833	88	350µF
RP08-1215SA**	9-18	15	533	843	87	240µF
RP08-243.3SA**	18-36	3.3	2000	362	80	3300µF
RP08-2405SA**	18-36	5	1500	396	83	1600µF
RP08-2412SA**	18-36	12	666	416	86	350µF
RP08-2415SA**	18-36	15	533	416	85	240µF
RP08-483.3SA**	36-75	3.3	2000	181	80	3300µF
RP08-4805SA**	36-75	5	1500	198	83	1600µF
RP08-4812SA**	36-75	12	666	208	86	350µF
RP08-4815SA**	36-75	15	533	208	86	240µF
RP08-1205DA**	9-18	±5	±800	843	83	±1000µF
RP08-1212DA**	9-18	±12	±333	833	87	±160µF
RP08-1215DA**	9-18	±15	±267	834	85	±100µF
RP08-2405DA**	18-36	±5	±800	427	82	±1000µF
RP08-2412DA**	18-36	±12	±333	422	86	±160µF
RP08-2415DA**	18-36	±15	±267	411	85	±100µF
RP08-4805DA**	36-75	±5	±800	211	85	±1000µF
RP08-4812DA**	36-75	±12	±333	206	87	±160µF
RP08-4815DA**	36-75	±15	±267	206	87	±100µF

** add Suffix SMD for SMD package

POWERLINE

DC/DC-Converter

with 3 year Warranty

RECOM

8 Watt DIP24/SMD Single & Dual Output

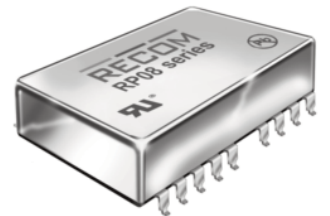

**UL-60950-1 Certified
E196683**

RP08

Derating Graph (Ambient Temperature)

RP08-4805SA

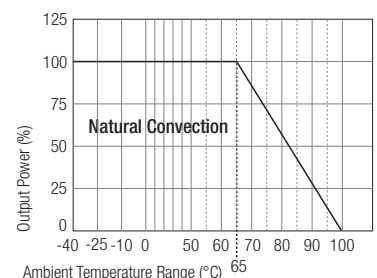

Derating graphs are valid only for the shown part numbers. If you need detailed derating-information about a part-number not shown here please contact our technical support service at info@recom-development.at

Refer to Application Notes

Specifications (typical at nominal input and 25°C unless otherwise noted)

Input Voltage Range ⁽⁹⁾	12V nominal input	9-18VDC
	24V nominal input	18-36VDC
	48V nominal input	36-75VDC
Input Filter		PI Type
Input Surge Voltage (100 ms max.)	12V Input	36VDC
	24V Input	50VDC
	48V Input	100VDC
Input Reflected Ripple (nominal Vin and full load)		20mA _{p-p}
Start Up Time (nominal Vin and constant resistor load)		600ms typ.
Remote ON/OFF ⁽⁷⁾	DC-DC ON	Open or 3.0V < Vr < 12V
	DC-DC OFF	Short or 0V < Vr < 1.2V
Remote OFF input current	Nominal input	2.5mA
Output Power		8W max.
Output Voltage Accuracy (full Load and nominal Vin)		±2%
Minimum Load ⁽¹⁾		10% of full load
Line Regulation (low line, high line at full load)		±0.2%
Load Regulation (25% to 100% full load)	Single	±0.5%
	Dual	±1%
Cross Regulation (asymmetrical 25% <-> 100% load)		±5%
Ripple and Noise (20MHz bandwidth, with 1µF MLCC on output)		50mV _{p-p}
Temperature Coefficient		±0.02%/°C max.
Transient Response (25% load step change)		200µs
Over Load Protection (% of full load at nominal Vin)		150% typ
Undervoltage Lockout		none
Short Circuit Protection		Continuous, automatic recovery
Efficiency		see „Selection Guide“ table
Isolation Voltage (rated for one minute)	In to out	1600VDC
	I/O to case	DIP type 1600VDC
	I/O to case	SMD type 1000VDC
Isolation Resistance		1 GΩ min.
Isolation Capacitance		300pF max.
Operating Frequency		100kHz min.
Approved to Safety Standards		UL 1950, EN60950
Operating Temperature Range		-40°C to +85°C(with derating)
Maximum Case Temperature		+100°C
Storage Temperature Range		-55°C to +125°C
Thermal Impedance	Natural convection	20°C/Watt
Thermal Shock		MIL-STD-810D
Vibration		10-55Hz, 10G, 30 Min. along X, Y and Z
Relative Humidity		5% to 95% RH

continued on next page

Specifications (typical at nominal input and 25°C unless otherwise noted)

Case Material		Nickel plated copper
Base Material		Non-conductive black plastic
Potting Material		Epoxy (UL94-V0)
Conducted Emissions ⁽⁸⁾	EN55022	Level A
Radiated Emissions	EN55022	Level A
ESD	EN61000-4-2	Perf. Criteria B
Radiated Immunity	EN61000-4-3	Perf. Criteria B
Fast Transient	EN61000-4-4	Perf. Criteria B
Surge	EN61000-4-5	Perf. Criteria B
Conducted Immunity	EN61000-4-6	Perf. Criteria B
Weight	DIP	16g
	SMD	18g
Packing Quantity	Refer to App Notes for tube dimensions	7 pcs per Tube
Dimensions	DIP	31.8 x 20.3 x 10.2mm
	SMD	32.0 x 20.3 x 10.9mm
MTBF ⁽²⁾		3165 x 10 ³ hours

Notes:

1. The RP08 series requires a minimum of 10% loading on the output to maintain specified regulation. Operation under no-load condition will not damage these devices, however they may not meet all listed specification.
2. BELLCORE TR-NWT-000332. Case I: 50% Stress, Temperature at 40°C (Ground fixed and controlled environment).
3. Start up voltage : 10VDC
4. Maximum value at nominal input voltage and full load of standard type.
5. Typical value at nominal input voltage and full load.
6. Test by minimum Vin and constant resistor load.
7. The ON/OFF control pin voltage is referenced to negative input.
8. Vin=12V, fit a 4.7µF 1210 MLCC capacitor across the input pins to meet EN55022 Class A. 24V and 48V Types meet Class A without external components See application notes for Class B Filter suggestion.

Package Style and Pinning (mm)

DIP24 Package Style

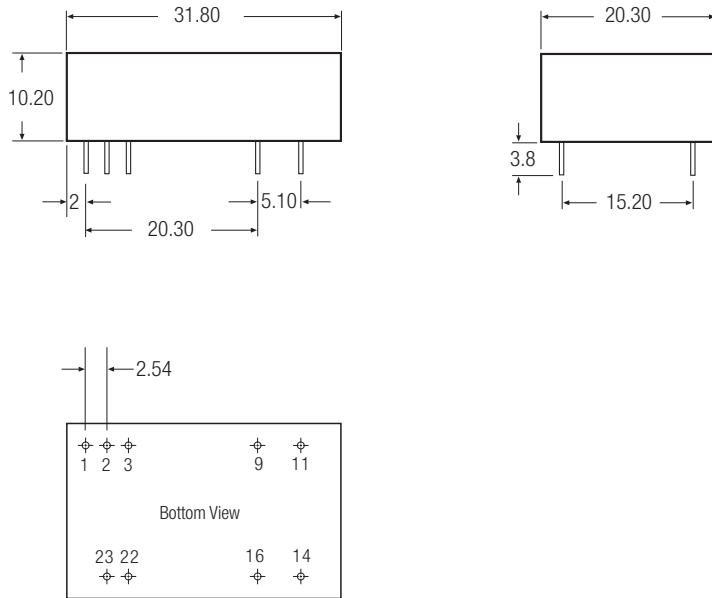

Pin Connections

Pin #	Single	Dual
1	ON/OFF	ON/OFF
2	-Vin	-Vin
3	-Vin	-Vin
9	NC	Com
11	NC	-Vout
14	+Vout	+Vout
16	-Vout	Com
22	+Vin	+Vin
23	+Vin	+Vin

NC = No Connection

Pin Pitch Tolerance ± 0.35 mm

SMD Package Style

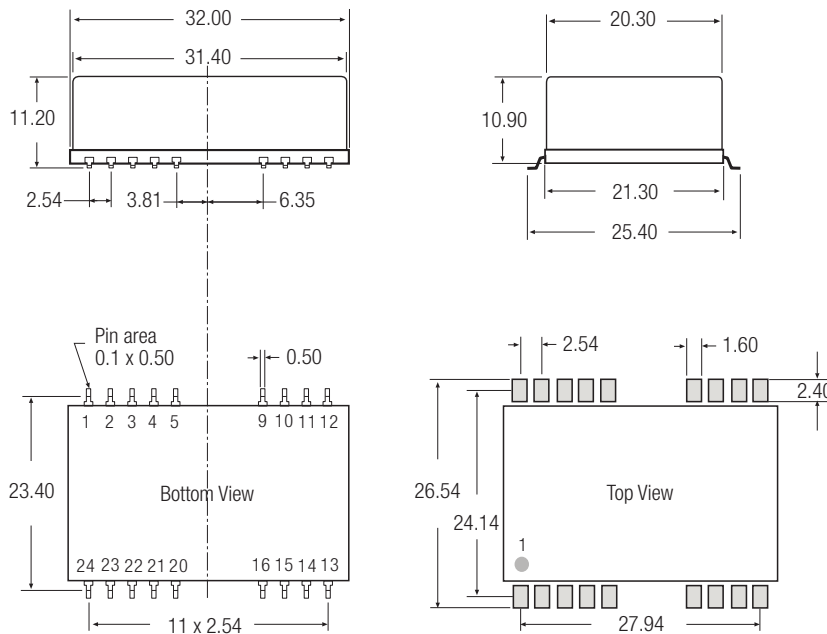

SMD Package Style

Same spec. as the original DIP spec. and pin definition, excl. of the SMD type pin.

Pin Connections

Pin #	Single	Dual
1	ON/OFF	ON/OFF
2	-Vin	-Vin
3	-Vin	-Vin
9	NC	Com
11	NC	-Vout
14	+Vout	+Vout
16	-Vout	Com
22	+Vin	+Vin
23	+Vin	+Vin
Others	NC	NC

NC = No Connection

Pin Pitch Tolerance ± 0.35 mm

The product information and specifications are subject to change without prior notice. All products are designed for non-safety critical commercial and industrial applications. The Buyer agrees to implement safeguards that anticipate the consequences of any failures that might cause harm, loss of life and/or damage property.

Features

Regulated Converters

- 4:1 Wide Input Voltage Ranges
- High Input Voltage Range (110VDC)
- 8 Watts Regulated Output Power
- 1.6kVDC Isolation
- Protected Outputs
- Five-Sided Shield
- No Derating to 81°C Ambient
- Standard DIP24 and SMD-Pinning
- Efficiency up to 88 %

Description

The RP08-AW series wide range input DC/DC converters are certified to UL 60950-1 and cUL 60950-1. This makes them ideal for all telecom and industrial applications where approved safety standards are required.

The 24V and 110VDC input versions have been especially designed for railway applications.

The DIP24 package is available in both pinned and SMD case styles and meets military standards for thermal shock and vibration tolerance.

Selection Guide 24V, 48 and 110V Wide Input Types

Part Number	Input Range VDC	Output Voltage VDC	Output Current mA	Input Current mA ^(4,5)	Efficiency % ⁽⁶⁾	Capacitive Load max. ⁽⁷⁾
RP08-243.3SAW**	9-40 ⁽⁹⁾	3.3	2400	40/407	85	1330µF
RP08-2405SAW**	9-40 ⁽⁹⁾	5	1600	40/402	87	1330µF
RP08-2412SAW**	9-40 ⁽⁹⁾	12	666	25/407	86	288µF
RP08-2415SAW**	9-40 ⁽⁹⁾	15	533	25/407	86	200µF
RP08-483.3SAW**	18-75	3.3	2400	20/204	85	1330µF
RP08-4805SAW**	18-75	5	1600	20/201	87	1330µF
RP08-4812SAW**	18-75	12	666	13/201	87	288µF
RP08-4815SAW**	18-75	15	533	13/198	88	200µF
RP08-1103.3SAW**	43-160	3.3	2400	8/90	85	1330µF
RP08-11005SAW**	43-160	5	1600	8/90	85	1330µF
RP08-11012SAW**	43-160	12	666	4/88	86	288µF
RP08-11015SAW**	43-160	15	533	4/88	86	200µF
RP08-2405DAW**	9-40 ⁽⁹⁾	±5	±800	20/417	84	±900µF
RP08-2412DAW**	9-40 ⁽⁹⁾	±12	±333	25/407	86	±133µF
RP08-2415DAW**	9-40 ⁽⁹⁾	±15	±267	25/407	86	±90µF
RP08-4805DAW**	18-75	±5	±800	10/208	84	±900µF
RP08-4812DAW**	18-75	±12	±333	13/201	87	±133µF
RP08-4815DAW**	18-75	±15	±267	13/201	87	±90µF
RP08-11005DAW**	43-160	±5	±800	5/93	82	±900µF
RP08-11012DAW**	43-160	±12	±333	5/90	85	±133µF
RP08-11015DAW**	43-160	±15	±267	5/90	85	±90µF

** add Suffix SMD for SMD package

POWERLINE

DC/DC-Converter

with 3 year Warranty

RECOM

8 Watt

DIP24/SMD,

Single &

Dual Output

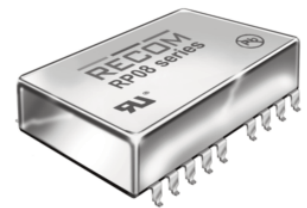

**UL-60950-1 Certified
E196683
(Except 110VDC Input
- UL Pending)**

RP08-W

Derating Graph

(Ambient Temperature)

RP08-4805SAW

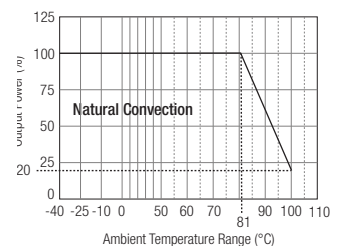

Derating graphs are valid only for the shown part numbers. If you need detailed derating information about a part-number not shown here please contact our technical support service at info@recom-development.at

Refer to Application Notes

Specifications (typical at nominal input and 25°C unless otherwise noted)

Input Voltage Range	24VDC Input	9-40VDC ⁽⁹⁾
	48VDC Input	18-75VDC
	110VDC Input	43-160VDC
Input Filter		Pi Type
Input Surge Voltage (100ms max)	24VDC Input	50VDC
	48VDC Input	100VDC
	110VDC Input	170VDC
Undervoltage Lockout	24VDC Input	Startup: 9V, Shutdown 8V
	48VDC Input	Startup: 18V, Shutdown 16V
	110VDC Input	Startup: 43V, Shutdown 42V
Input Reflected Ripple (nominal Vin and full load)		20mA _{p-p}
Start Up Time (nominal Vin and constant resistor load)		450ms typ.
Remote ON/OFF ⁽¹⁾	DC-DC ON	Open or 3.0V < Vr < 12V
	DC-DC OFF	Short or 0V < Vr < 1.2V
Remote OFF input current	Nominal input	2.5mA
Output Power		8W max.
Output Voltage Accuracy (full Load and nominal Vin)		±1%
Minimum Load		0%
Line Regulation (low line, high line at full load)		±0.2%
Load Regulation (0% to 100% Load)	Single (0% to 100% Load)	±0.5%
	Dual (0% to 100% Load)	±1.0%
	Single (10% to 90% Load)	±0.3%
	Dual (10% to 90% Load)	±0.8%
Cross Regulation Dual Output (asymmetrical 25% <-> 100% load)		±5%
Ripple and Noise (20MHz bandwidth, with 1µF MLCC on output)		75mV _{p-p}
Temperature Coefficient		±0.02%/°C max.
Transient Response (25% load step change)		250µs
Input Voltage Variation, dv/dt	complies with ETS300 132, part 4.4	5V/ms
Over Load Protection (% of full load at nominal Vin)		150% typ
Overvoltage Protection	3.3V	3.9V
	5.1V	6.2V
Single output only		
Zener Diode Clamp	12V	15V
	15V	18V
Undervoltage Lockout		See Application Notes
Short Circuit Protection		Continuous, automatic recovery
Efficiency		see „Selection Guide“ table
Isolation Voltage (rated for one minute)	In to Out and I/O to Case	1600VDC
	I/O to Case (SMD)	1000VDC
Isolation Resistance		1 GΩ min.
Isolation Capacitance		1500pF max.
Operating Frequency		300kHz typ.
Operating Temperature Range (no derating)	5, 12, 15, ±12, ±15V	-40°C to +78°C
	3.3, ±5V	-40°C to +74°C
	(with derating)	All types
Maximum Case Temperature		+105°C
Storage Temperature Range		-55°C to +125°C
Thermal Impedance	Natural convection	20°C/Watt

continued on next page

Specifications (typical at nominal input and 25°C unless otherwise noted)

Case Material	Nickel-coated copper with non-conductive black plastic base	
Potting Material	Epoxy (UL94-V0)	
Weight	18g (DIP), 20g (SMD)	
Packing Quantity	Refer to App Notes for tube dimensions	7pcs per Tube
Packing Quantity	Refer to App Notes for tube dimensions	7pcs per Tube
Conducted Emissions ⁽⁹⁾	EN55022	Class A
Radiated Emissions	EN55022	Class B
ESD	EN61000-4-2	Perf. Criteria A
Radiated Immunity	EN61000-4-3	Perf. Criteria A
Fast Transient ⁽⁹⁾	EN61000-4-4	Perf. Criteria A
Surge ⁽⁹⁾	EN61000-4-5	Perf. Criteria A
Conducted Immunity	EN61000-4-6	Perf. Criteria A
Thermal Shock	MIL-STD-810F	
Vibration	10-55Hz, 10G, 30 Min. along X, Y and Z	
Relative Humidity	5% to 95% RH	
MTBF ⁽²⁾	Bellcore-TR-NWT-000332	2350 x 10 ³ hours
	MIL-HDBK-217F	1078 x 10 ³ hours

Notes :

1. The ON/OFF control pin voltage is referenced to negative input.
2. BELLCORE TR-NWT-000332. Case I: 50% Stress, Temperature at 40°C (Ground Benign and controlled environment). Mil-HDBK-217F, Notice 2, Full Load, 25°C, Ground Benign.
3. Vin=24V, fit a 1.0µF/50V 1210 MLCC capacitor across the input pins to meet EN55022 Class A.
Vin=48V, fit a 0.47µF/100V 1810 MLCC capacitor across the input pins to meet EN55022 Class A.
Vin=110V, fit 2x 0.47µF/250V 1810 MLCC capacitor in parallel across the input pins to meet EN55022 Class A
See application notes for Class B Filter suggestion.
4. Typical value at nominal input voltage and no load.
5. Maximum value at nominal input voltage and full load
6. Typical value at nominal input voltage and full load.
7. Test by minimum Vin and constant resistor load.
8. Meets EN61000-4-4,-5 with a capacitor across the input. Recom suggests Nippon Chemi-Con KY series, 220µF/100V (24V and 48V) or 150µF/200V (110V)
9. The 24V input voltage range can be used up to 40VDC for 1 second. For a continuous input voltage, 36V is the limit.

Typical Performance Graphs

RP08-4805SAW

Efficiency VS Input Voltage

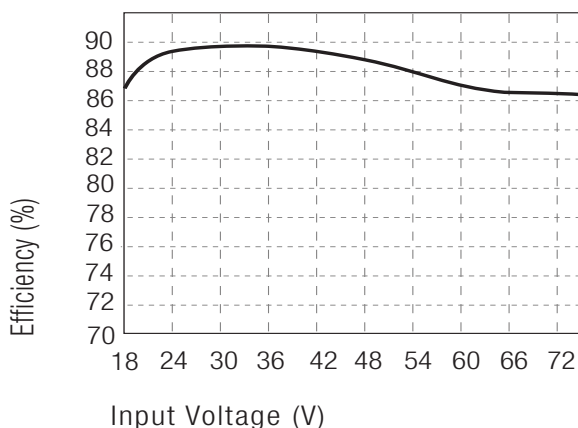

Efficiency VS Output load

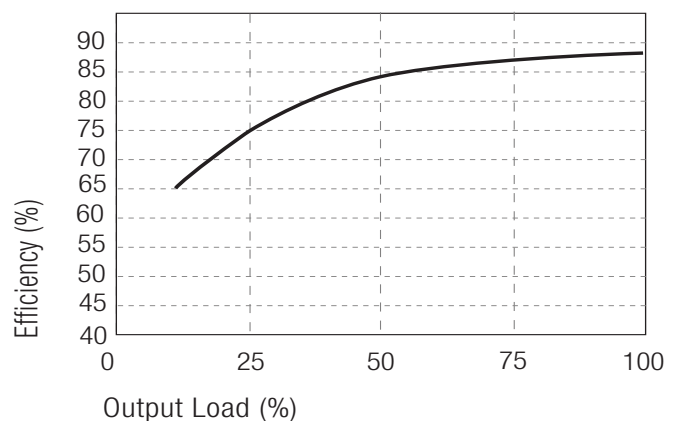

Class B Filter

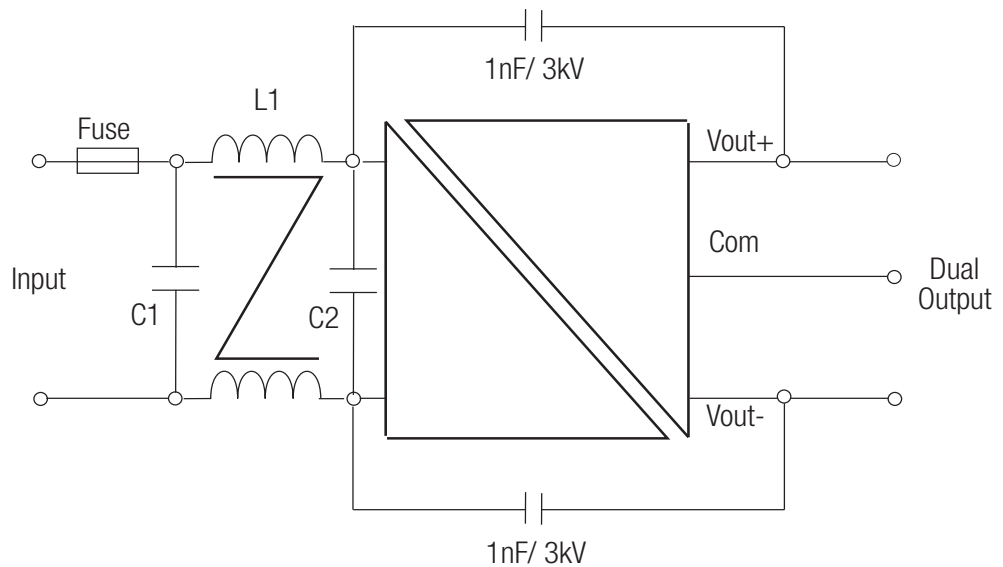
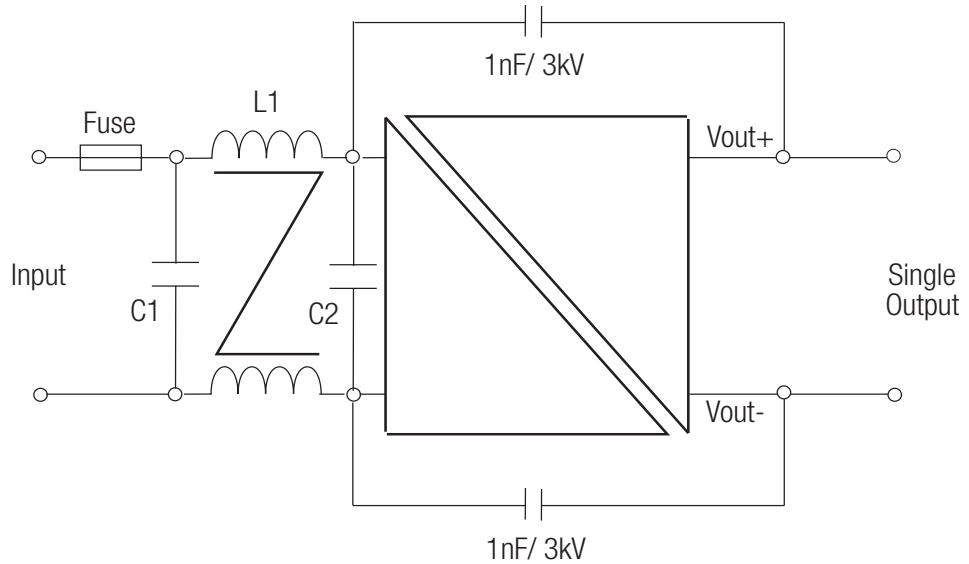

Vin=24V: C1=4.7μF/50V 1812 MLCC, L1 = Würth 7448229004 350μH , C2=omit

Vin=48V: C1= 1.5μF/100V 1812 MLCC, L1 = Würth 7448229004 350μH, C2=1.5μF/100V 1812 MLCC

Vin=110V: C1= 0.47μF/250V 1812 MLCC, L1 = Würth 7448229004 350μH, C2=0.47μF/250V 1812 MLCC

Package Style and Pinning (mm)

DIP24 Package Style

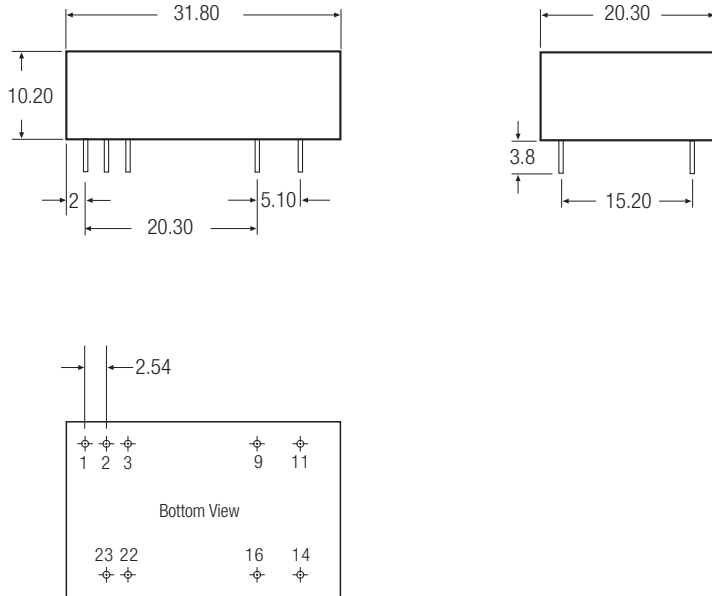

Pin Connections

Pin #	Single	Dual
1	ON/OFF	ON/OFF
2	-Vin	-Vin
3	-Vin	-Vin
9	NC	Com
11	NC	-Vout
14	+Vout	+Vout
16	-Vout	Com
22	+Vin	+Vin
23	+Vin	+Vin

NC = No Connection

Pin Pitch Tolerance ± 0.35 mm

SMD Package Style and Pinning (mm) (Same spec. as the original DIP spec. and pin definition, excl. of the SMD Typ pin.)

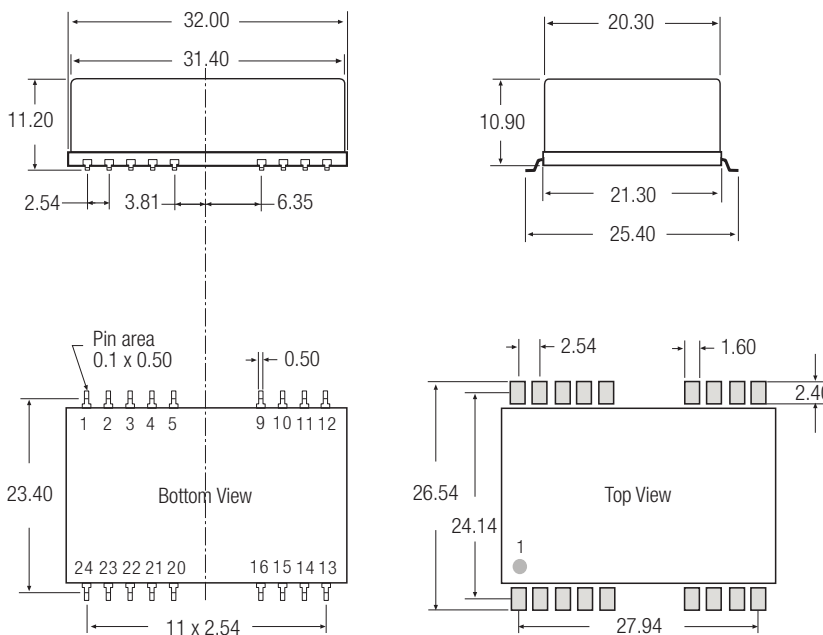

Pin Connections

Pin #	Single	Dual
1	ON/OFF	ON/OFF
2	-Vin	-Vin
3	-Vin	-Vin
9	NC	Com
11	NC	-Vout
14	+Vout	+Vout
16	-Vout	Com
22	+Vin	+Vin
23	+Vin	+Vin
Others	NC	NC

NC = No Connection

Pin Pitch Tolerance ± 0.35 mm

The product information and specifications are subject to change without prior notice. All products are designed for non-safety critical commercial and industrial applications. The Buyer agrees to implement safeguards that anticipate the consequences of any failures that might cause harm, loss of life and/or damage property.

Features

- 2:1 Wide Input Voltage Range
- 10 Watts Output Power
- 1.6kVDC Isolation
- UL Certified
- Fixed Operating Frequency
- Six-Sided Continuous Shield
- Standard 50.8 x 25.4 x 10.2mm Package
- Efficiency to 86 %

Description

The RP10-E series DC/DC converters are certified to UL 60950-1 and cUL 60950-1. This makes them ideal for all telecom and industrial applications where approved safety standards are required. The industry standard 2" x 1" package meets military standards for thermal shock and vibration tolerance and is available with an optional remote on/off control pin. This series is also available with the /M1 option which is particularly suitable for extended temperature range applications.

Selection Guide 12V, 24V and 48V Input Types

Part Number	Input Range VDC	Output Voltage VDC	Output Current mA	Input Current mA ⁽⁴⁾	Efficiency % ⁽⁵⁾	Capacitive Load max. ⁽⁶⁾
RP10-1205SE	9-18	5	2000	1082	81	4700µF
RP10-1212SE	9-18	12	830	1064	82	690µF
RP10-1215SE	9-18	15	670	1088	81	470µF
RP10-2405SE	18-36	5	2000	534	82	4700µF
RP10-2412SE	18-36	12	830	519	84	690µF
RP10-2415SE	18-36	15	670	523	84	470µF
RP10-4805SE	36-75	5	2000	260	84	4700µF
RP10-4812SE	36-75	12	830	253	86	690µF
RP10-4815SE	36-75	15	670	258	85	470µF
RP10-1205DE	9-18	±5	±1000	1068	82	±680µF
RP10-1212DE	9-18	±12	±416	1053	83	±330µF
RP10-1215DE	9-18	±15	±333	1041	84	±110µF
RP10-2405DE	18-36	±5	±1000	548	80	±680µF
RP10-2412DE	18-36	±12	±416	520	84	±330µF
RP10-2415DE	18-36	±15	±333	520	84	±110µF
RP10-4805DE	36-75	±5	±1000	267	82	±680µF
RP10-4812DE	36-75	±12	±416	254	86	±330µF
RP10-4815DE	36-75	±15	±333	260	84	±110µF

* add suffix /M1 for higher efficiencies and extended temperature range.

* add suffix /P for CTRL function with Positive Logic (1=ON, 0=OFF)

* add suffix /N for CTRL function with Negative Logic (0=ON, 1=OFF)

* add suffix -HC for premounted heatsink and clips

Ordering Examples

RP10-1205SE/P = 12V Input, 5V Output, Standard Temp. Range, Positive Logic CTRL pin fitted

RP10-4805DE/M1-HC = 48V Input, ±5V Output, Extended Temp. Range, No CTRL pin, Heatsink fitted

POWERLINE

DC/DC-Converter

with 3 year Warranty

RECOM

10 Watt

2" x 1"

Single &

Dual Output



UL-60950-1 Certified
E196683

RP10-E

Refer to Application Notes

Derating Graph (Ambient Temperature)

RP10-2405SE

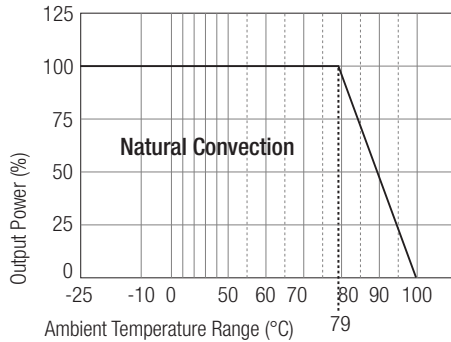

RP10-2405SE With Heat Sink

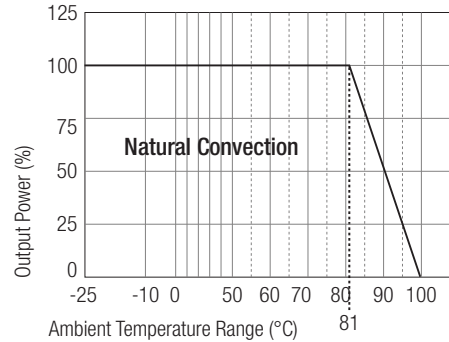

RP10-2405DE

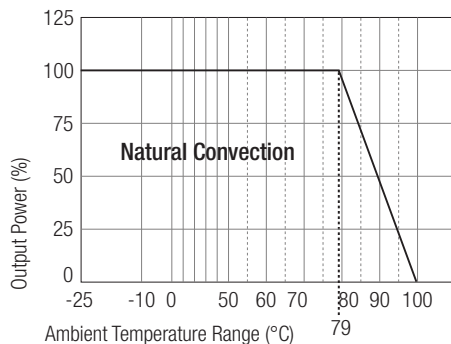

RP10-2405DE With Heat Sink

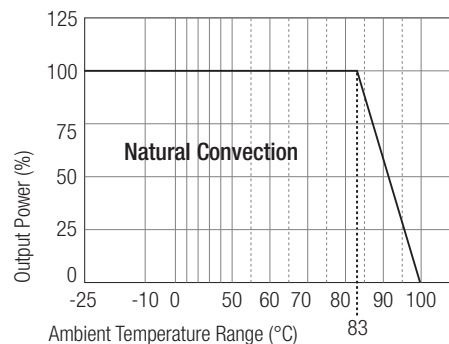

RP10-4805SE

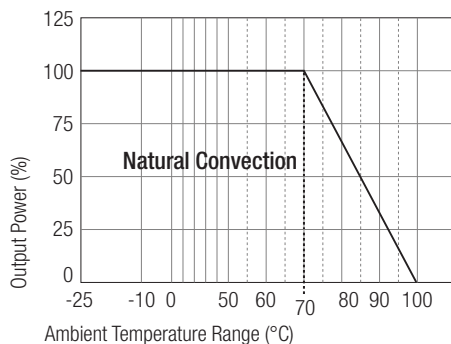

RP10-2405SE_DE/M1

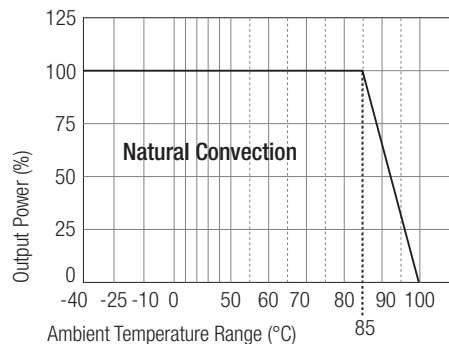

RP10-4805SE/M1

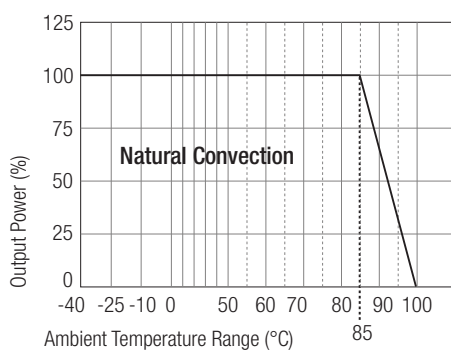

RP10-2405SE_DE/M1 With Heat Sink

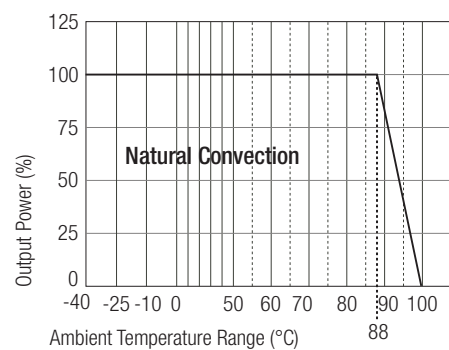

RP10-E

Derating graphs are valid only for the shown part numbers. If you need detailed derating-information about a part-number not shown here please contact our technical support service at info@recom-development.at

Specifications (typical at nominal input and 25°C unless otherwise noted)

Input Voltage Range	12V nominal input	9-18VDC
	24V nominal input	18-36VDC
	48V nominal input	36-75VDC
Input Filter		Pi Type
Input Surge Voltage (100 ms max.)	12V Input	36VDC
	24V Input	50VDC
	48V Input	100VDC
Input Reflected Ripple (nominal Vin and full load) ⁽³⁾		30mA _{p-p}
Start Up Time (nominal Vin and constant resistor load)		20ms typ.
Remote ON/OFF ⁽⁷⁾		
(Positive logic)	DC-DC ON	Open or 3.5V < Vr < 12V
	DC-DC OFF	Short or 0V < Vr < 1.2V
(Negative logic)	DC-DC ON	Short or 0V < Vr < 1.2V
	DC-DC OFF	Open or 3.5V < Vr < 12V
Remote OFF input current	Nominal input	20mA
Output Power		10W max.
Output Voltage Accuracy (full Load and nominal Vin)		±2%
Minimum Load ⁽¹⁾		10% of full load
Line Regulation (low line, high line at full load)		±1%
Load Regulation (25% to 100% full load)	Single	±1%
	Dual	±2%
Cross Regulation (asymmetrical 25% <-> 100% load)		±5%
Ripple and Noise (20MHz bandwidth, with 1µF MLCC on output)	Single	50mV _{p-p}
	Dual	75mV _{p-p}
Temperature Coefficient		±0.02%/°C max.
Transient Response (25% load step change)		500µs
Over Voltage Protection	3.3V output	3.9V
Zener diode clamp	5V output	6.2V
	12V output	15V
	15V output	18V
Over Load Protection (% of full load at nominal Vin)		150% typ
Undervoltage Lockout		none
Short Circuit Protection		Hiccup, automatic recovery
Efficiency		see „Selection Guide“ table
Isolation Voltage (rated for one minute)		1600VDC
Isolation Resistance		1 GΩ min.
Isolation Capacitance		300pF max.
Operating Frequency		300kHz typ.
Approved to Safety Standards ⁽⁹⁾		UL 1950, EN60950
Operating Temperature Range (Reference Derating Curve) ⁽¹⁰⁾	Standard	-25°C to +85°C (with derating)
	M1	-40°C to +85°C (non derating)
Maximum Case Temperature		+100°C
Storage Temperature Range		-55°C to +125°C

continued on next page

Specifications (typical at nominal input and 25°C unless otherwise noted)

Thermal Impedance ⁽⁸⁾	Natural convection	12°C/Watt
	Natural convection with Heat Sink	10°C/Watt
Thermal Shock	MIL-STD-810D	
Vibration	10-55Hz, 10G, 30 Min. along X, Y and Z	
Relative Humidity	5% to 95% RH	
Case Material	Nickel plated copper	
Base Material	Non-conductive black plastic	
Potting Material	Epoxy (UL94-V0)	
Conducted Emissions ⁽¹¹⁾	EN55022	Level A
Radiated Emissions	EN55022	Level A
ESD	EN61000-4-2	Perf. Criteria B
Radiated Immunity	EN61000-4-3	Perf. Criteria B
Fast Transient	EN61000-4-4	Perf. Criteria B
Surge	EN61000-4-5	Perf. Criteria B
Conducted Immunity	EN61000-4-6	Perf. Criteria B
Weight	27g	
Packing Quantity	Refer to App Notes for tube dimensions	9 pcs per Tube
Dimensions	50.8 x 25.4 x 10.2mm	
MTBF ⁽²⁾	1976 x 10 ³ hours	

Package Style and Pinning (mm)

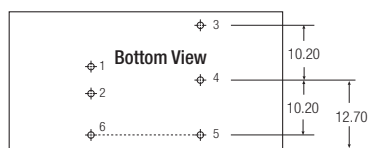
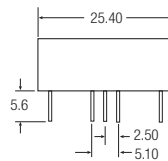
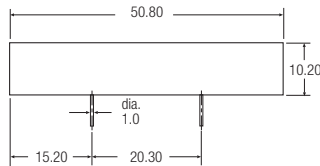

Pin Connections

Pin #	Single	Dual
1	+Vin	+Vin
2	-Vin	-Vin
3	+Vout	+Vout
4	No Pin	Com
5	-Vout	-Vout
6*	CTRL*	CTRL*

*Optional. See Note 7.

Pin Pitch Tolerance ±0.35 mm

Notes :

- The RP10 (W) series required a minimum 10% loading on the output to maintain specified regulation.
Operation under no-load condition will not damage these devices, however they may not meet all listed specification.
- BELLCORE TR-NWT-000332. Case I: 50% Stress, Temperature at 40°C. (Ground fixed and controlled environment).
- Simulated source impedance of 12µH. 12µH inductor in series with +Vin.
- Maximum value at nominal input voltage and full load of standard type.
- Typical value at nominal input voltage and full load.
- Test by minimum Vin and constant resistor load.
- The ON/OFF control function can be positive or negative logic. The pin voltage is referenced to negative input.
Positive logic ON/OFF is marked with suffix-P (eg. RP10-2405SE/P), Negative logic ON/OFF is marked with suffix-N (eg. RP10-2405SE/N).
If no suffix is specified, the control pin will be omitted.
- Heat sink is optional and P/N: 7G-0020C. Powerline DC/DC Converters can be ordered with pre-mounted heatsinks including antivibration fixing clips (add suffix -HC). See Application Notes for heatsink details.
- The M1 version (RP10-xxxxSE/M1, RP10-xxxxDE/M1) does not carry the UL certification.
- M1 version is more efficient, therefore, it can be operated in a more extensive temperature range than standard version.
- See application notes for EMI-filtering.

The product information and specifications are subject to change without prior notice. All products are designed for non-safety critical commercial and industrial applications.
The Buyer agrees to implement safeguards that anticipate the consequences of any failures that might cause harm, loss of life and/or damage property.

Features

- 4:1 Wide Input Voltage Range
- 10 Watts Output Power
- 1.6kVDC Isolation
- Fixed Operating Frequency
- Six-Sided Continuous Shield
- Standard 50.8 x25.4x10.2mm Package
- Efficiency to 84%

Description

The RP10-EW series wide input range DC/DC converter are certified to UL 60950-1 and cUL 60950-1. This makes them ideal for all telecom and industrial applications where approved safety standards are required.

The industry standard 2" x 1" package meets military standards for thermal shock and vibration tolerance and is available with an optional remote on/off control pin.

This series is also available with the /M2 option which is particularly suitable for extended temperature range applications.

Selection Guide 24V and 48V Input Types

Part Number	Input Range VDC	Output Voltage VDC	Output Current mA	Input ⁽⁴⁾ Current mA	Efficiency ⁽⁵⁾ %	Capacitive ⁽⁶⁾ Load max.
RP10-2405SEW	9-36	5	2000	548	80	4700µF
RP10-2412SEW	9-36	12	830	532	82	690µF
RP10-2415SEW	9-36	15	670	551	80	470µF
RP10-4805SEW	18-75	5	2000	274	80	4700µF
RP10-4812SEW	18-75	12	830	259	84	690µF
RP10-4815SEW	18-75	15	670	262	84	470µF
RP10-2405DEW	9-36	±5	±1000	548	80	±680µF
RP10-2412DEW	9-36	±12	±416	547	80	±330µF
RP10-2415DEW	9-36	±15	±333	548	80	±110µF
RP10-4805DEW	18-75	±5	±1000	271	81	±680µF
RP10-4812DEW	18-75	±12	±416	281	78	±330µF
RP10-4815DEW	18-75	±15	±333	270	81	±110µF

* add suffix /M2 for higher efficiencies and extended temperature range.

* add suffix /P for CTRL function with Positive Logic (1=ON, 0=OFF)

* add suffix /N for CTRL function with Negative Logic (0=ON, 1=OFF)

* add suffix -HC for premounted heatsink and clips

Ordering Examples

RP10-2405SE/P = 24V 4:1 Input, 5V Output, Standard Temp. Range, Positive Logic CTRL pin fitted

RP10-4805DE/M1-HC = 48V 4:1 Input, ±5V Output, Extended Temp. Range, No CTRL, Heatsink fitted

POWERLINE

DC/DC-Converter

with 3 year Warranty

RECOM

10 Watt

2" x 1"

Single &

Dual Output



UL-60950-1 Certified
E196683

RP10-EW

Refer to Application Notes

Derating Graph (Ambient Temperature)

RP10-2405SEW

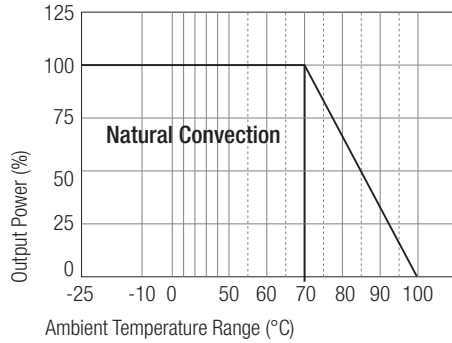

RP10-2405SEW With Heat Sink

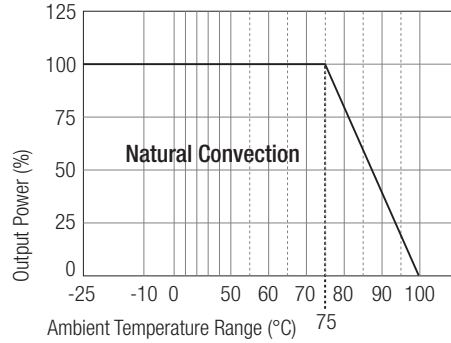

RP10-2405DEW

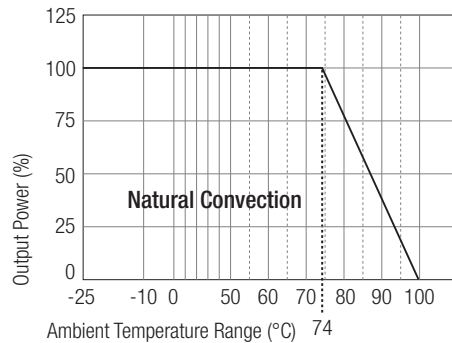

RP10-2405DEW With Heat Sink

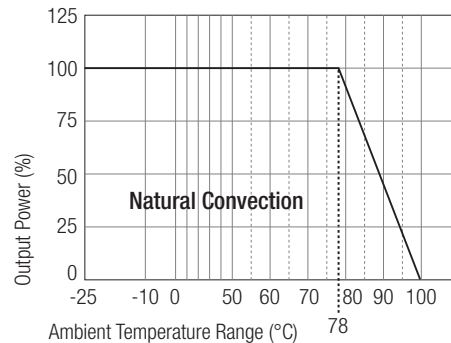

RP10-2405SEW/M2

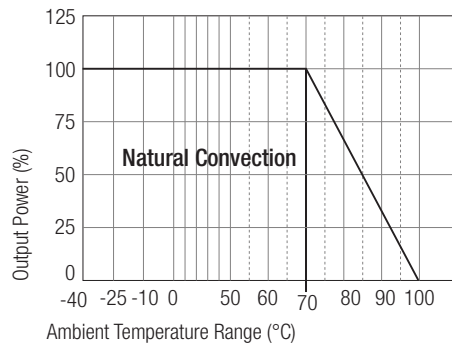

RP10-2405SEW/M2 With Heat Sink

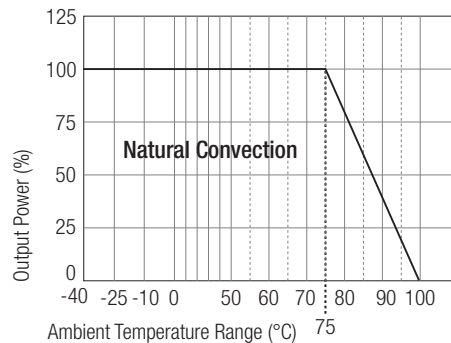

RP10-2405DEW/M2

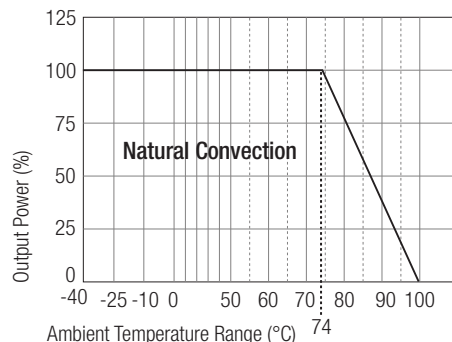

RP10-2405DEW/M2 With Heat Sink

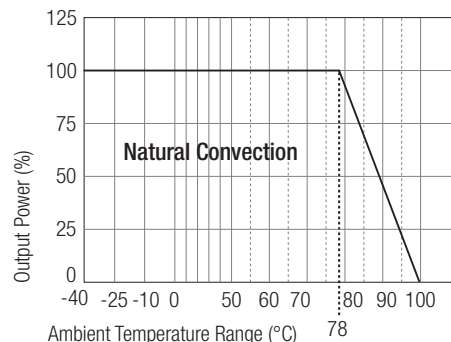

RP10-EW

Derating graphs are valid only for the shown part numbers. If you need detailed derating-information about a part-number not shown here please contact our technical support service at info@recom-development.at

Specifications (typical at nominal input and 25°C unless otherwise noted)

Input Voltage Range	24V nominal input	9-36VDC
	48V nominal input	18-75VDC
Input Filter		Pi Type
Input Surge Voltage (100 ms max.)	24V Input	50VDC
	48V Input	100VDC
Input Reflected Ripple (nominal Vin and full load)		30mA _{p-p}
Start Up Time (nominal Vin and constant resistor load)		20ms typ.
Remote ON/OFF ⁽⁷⁾		
(Positive logic)	DC-DC ON	Open or 3.5V < Vr < 12V
	DC-DC OFF	Short or 0V < Vr < 1.2V
(Negative logic)	DC-DC ON	Short or 0V < Vr < 1.2V
	DC-DC OFF	Open or 3.5V < Vr < 12V
Remote OFF input current	Nominal input	20mA
Output Power		10W max.
Output Voltage Accuracy (full Load and nominal Vin)		±2%
Minimum Load ⁽¹⁾		10% of full load
Line Regulation (low line, high line at full load)		±1%
Load Regulation (25% to 100% full load)	Single	±1%
	Dual	±2%
Cross Regulation (asymmetrical 25%<->100% load)		±5%
Ripple and Noise (20MHz bandwidth, with 1µF MLCC on output)	Single	50mV _{p-p}
	Dual	75mV _{p-p}
Temperature Coefficient		±0.02%/°C max.
Transient Response (25% load step change)		500µs
Over Voltage Protection	5V output	6.2V
Zener diode clamp	12V output	15V
	15V output	18V
Over Load Protection (% of full load at nominal Vin)		150% typ
Undervoltage Lockout		none
Short Circuit Protection		Hiccup, automatic recovery
Efficiency		see „Selection Guide“ table
Isolation Voltage (rated for one minute)		1600VDC
Isolation Resistance		1 GΩ min.
Isolation Capacitance		300pF max.
Operating Frequency		300kHz typ.
Operating Temperature Range ⁽⁹⁾ (Reference Derating Curve)	Standard	-25°C to +85°C(with derating)
	M2	-40°C to +85°C(with derating)
Maximum Case Temperature		+100°C
Storage Temperature Range		-55°C to +125°C
Thermal Impedance ⁽⁸⁾	Natural convection	12°C/Watt
	Natural convection with Heat Sink	10°C/Watt
Thermal Shock		MIL-STD-810D
Vibration		10-55Hz, 10G, 30 Min. along X, Y and Z

continued on next page

Specifications (typical at nominal input and 25°C unless otherwise noted)

Relative Humidity		5% to 95% RH
Case Material		Nickel plated copper
Base Material		Non-conductive black plastic
Potting Material		Epoxy (UL94-V0)
Conducted Emissions ⁽¹⁰⁾	EN55022	Level A
Radiated Emissions	EN55022	Level A
ESD	EN61000-4-2	Perf. Criteria B
Radiated Immunity	EN61000-4-3	Perf. Criteria B
Fast Transient	EN61000-4-4	Perf. Criteria B
Surge	EN61000-4-5	Perf. Criteria B
Conducted Immunity	EN61000-4-6	Perf. Criteria B
Weight		27g
Packing Quantity	Refer to App Notes for tube dimensions	9pcs per Tube
Dimensions		50.8 x 25.4 x 10.2mm
MTBF ⁽²⁾	BELLCORE TR-NWT-000332	1976 x 10 ³ hours
	MIL-HDBK-217F	1416 x 10 ³ hours

Package Style and Pinning (mm)

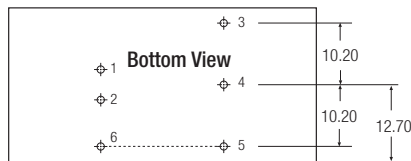
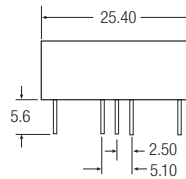
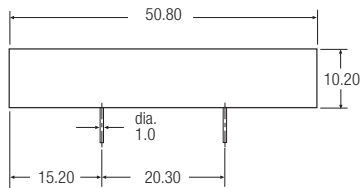

Pin Connections

Pin #	Single	Dual
1	+Vin	+Vin
2	-Vin	-Vin
3	+Vout	+Vout
4	No Pin	Com
5	-Vout	-Vout
6*	CTRL*	CTRL*

* Optional. See Note 7

Pin Pitch Tolerance ± 0.35 mm

Notes :

- The RP10 (W) series required a minimum 10% loading on the output to maintain specified regulation. Operation under no-load condition will not damage these devices, however they may not meet all listed specification.
- BELLCORE TR-NWT-000332. Case I: 50% Stress, Temperature at 40°C. (Ground fixed and controlled environment).
- Simulated source impedance of 12 μ H. 12 μ H inductor in series with +Vin.
- Maximum value at nominal input voltage and full load of standard type.
- Typical value at nominal input voltage and full load.
- Test by minimum Vin and constant resistor load.
- The ON/OFF control function can be positive or negative logic. The pin voltage is referenced to negative input.
Positive logic ON/OFF is marked with suffix-P (eg. RP10-2405SEW/P)
Negative logic ON/OFF is marked with suffix-N (eg. RP10-2405SEW/N).
If no suffix is specified, the control pin will be omitted.
- Heat sink is optional and P/N: 7G-0020C. Powerline DC/DC Converters can be ordered with pre-mounted heatsinks including antivibration fixing clips (add suffix -HC). See Application Notes for heatsink details.
- M2 version is more efficient, therefore, it can be operated in a more extensive temperature range than standard version.
- See application notes for EMI-filtering.

The product information and specifications are subject to change without prior notice. All products are designed for non-safety critical commercial and industrial applications. The Buyer agrees to implement safeguards that anticipate the consequences of any failures that might cause harm, loss of life and/or damage property.

Features

- 2:1 Wide Input Voltage Range
- 12 Watts Output Power
- 1.6kVDC Isolation
- UL Certified
- Over Current Protection
- Five-Sided Shield
- Standard DIP24 and SMD-Pinning
- Efficiency to 88 %

Description

The RP12-A series DC/DC converter are certified to UL 60950-1 and cUL 60950-1. This makes them ideal for all telecom and industrial applications where approved safety standards are required. The DIP24 package is available in both pinned and SMD case styles and meets military standards for thermal shock and vibration tolerance.

Selection Guide 12V, 24V and 48V Input Types

Part Number	Input Range VDC	Output Voltage VDC	Output Current mA	Input ⁽⁴⁾ Current mA	Efficiency ⁽⁵⁾ %	Capacitive ⁽⁶⁾ Load max.
DIP24 (SMD)						
RP12-123.3SA**	9-18	3.3	3500	1646	84	2000µF
RP12-1205SA**	9-18	5	2400	1606	86	2000µF
RP12-1212SA**	9-18	12	1000	1606	86	430µF
RP12-1215SA**	9-18	15	800	1606	86	300µF
RP12-243.3SA**	18-36	3.3	3500	823	85	2000µF
RP12-2405SA**	18-36	5	2400	803	87	2000µF
RP12-2412SA**	18-36	12	1000	803	87	430µF
RP12-2415SA**	18-36	15	800	803	87	300µF
RP12-483.3SA**	36-75	3.3	3500	411	85	2000µF
RP12-4805SA**	36-75	5	2400	401	87	2000µF
RP12-4812SA**	36-75	12	1000	401	87	430µF
RP12-4815SA**	36-75	15	800	401	87	300µF
RP12-1205DA**	9-18	±5	±1200	1687	82	±1250µF
RP12-1212DA**	9-18	±12	±500	1626	87	±200µF
RP12-1215DA**	9-18	±15	±400	1626	87	±120µF
RP12-2405DA**	18-36	±5	±1200	843	83	±1250µF
RP12-2412DA**	18-36	±12	±500	813	88	±200µF
RP12-2415DA**	18-36	±15	±400	813	88	±120µF
RP12-4805DA**	36-75	±5	±1200	422	83	±1250µF
RP12-4812DA**	36-75	±12	±500	406	88	±200µF
RP12-4815DA**	36-75	±15	±400	406	88	±120µF

** add Suffix SMD for SMD package

RP12-A

POWERLINE

DC/DC-Converter

with 3 year Warranty

RECOM

12 Watt DIP24/SMD Single & Dual Output



**UL-60950-1 Certified
E196683**

RP12-A

Derating Graph (Ambient Temperature)

RP12-4805SA

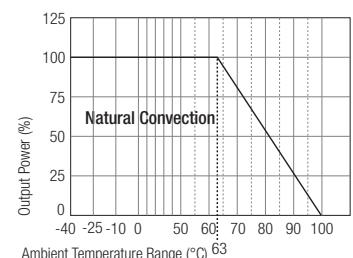

Derating graphs are valid only for the shown part numbers. If you need detailed derating-information about a part-number not shown here please contact our technical support service at info@recom-development.at

Refer to Application Notes

Specifications (typical at nominal input and 25°C unless otherwise noted)

Input Voltage Range	12V nominal input	9-18VDC
	24V nominal input	18-36VDC
	48V nominal input	36-75VDC
Under Voltage Lockout	12V Input DC-DC ON	9VDC
	DC-DC OFF	8VDC
	24V Input DC-DC ON	18VDC
	DC-DC OFF	16VDC
	48V Input DC-DC ON	36VDC
	DC-DC OFF	33VDC
Input Filter		Pi Type
Input Voltage Variation dv/dt	(Complies with ETS300 132 part 4.4)	5V/ms max.
Input Surge Voltage (100 ms max.)	12V Input	36VDC
	24V Input	50VDC
	48V Input	100VDC
Input Reflected Ripple (nominal Vin and full load) ⁽³⁾		20mA _{p-p}
Start Up Time (nominal Vin and constant resistor load)		600ms typ.
Remote ON/OFF ⁽⁷⁾	DC-DC ON	Open or 3.0V < Vr < 12V
	DC-DC OFF	Short or 0V < Vr < 1.2V
Remote OFF input current	Nominal input	2.5mA
Output Power		12W max.
Output Voltage Accuracy (full Load and nominal Vin)		±1.2%
Minimum Load ⁽¹⁾		10% of full load
Line Regulation (low line, high line at full load)	Single	±0.2%
	Dual	±0.5%
Load Regulation (25% to 100% full load)	Single	±0.5%
	Dual	±1%
Cross Regulation (asymmetrical 25% <> 100% load)		±5%
Ripple and Noise (20MHz bandwidth, with 1µF MLCC on output)		85mV _{p-p}
Temperature Coefficient		±0.02%/°C max.
Transient Response (25% load step change)		300µs
Over Voltage Protection	3.3V	3.9V
Zener diode clamp (only single)	5V	6.2V
	12V	15V
	15V	18V
Over Load Protection (% of full load at nominal Vin)		150% typ
Undervoltage Lockout		See Application Notes
Short Circuit Protection		Continuous, automatic recovery
Efficiency		see „Selection Guide“ table
Isolation Voltage (rated for one minute)	In to out	1600VDC min.
	I/O to case	1600VDC min.
Isolation Resistance		1 GΩ min.
Isolation Capacitance		1200pF max.

continued on next page

Specifications (typical at nominal input and 25°C unless otherwise noted)

Operating Frequency		400kHz typ.
Operating Temperature Range		-40°C to +85°C (with derating)
Maximum Case Temperature		+100°C
Storage Temperature Range		-55°C to +125°C
Thermal Impedance	Natural convection	20°C/Watt
Thermal Shock		MIL-STD-810D
Vibration		10-55Hz, 10G, 30 Min. along X, Y and Z
Relative Humidity		5% to 95% RH
Case Material		Nickel plated copper
Base Material		Non-conductive black plastic
Potting Material		Epoxy (UL94-V0)
Conducted Emissions ⁽⁸⁾	EN55022	Class A
Radiated Emissions	EN55022	Class A
ESD	EN61000-4-2	Perf. Criteria B
Radiated Immunity	EN61000-4-3	Perf. Criteria B
Fast Transient	EN61000-4-4	Perf. Criteria B
Surge	EN61000-4-5	Perf. Criteria B
Conducted Immunity	EN61000-4-6	Perf. Criteria B
Weight	DIP	18g
	SMD	20g
Packing Quantity	Refer to App Notes for tube dimensions	7pcs per Tube
Dimensions		31.8 x 20.3 x 10.2mm
MTBF ⁽²⁾		2750 x 10 ³ hours

Notes :

1. The RP12 series requires a minimum of 10% loading on the output to maintain specified regulation. Operation under no-load condition will not damage these devices, however they may not meet all listed specification.
2. BELLCORE TR-NWT-000332. Case I: 50% Stress, Temperature at 40°C (Ground fixed and controlled environment).
3. Simulated source impedance of 12μH. 12μH inductor in series with +Vin.
4. Maximum value at nominal input voltage and full load of standard type.
5. Typical value at nominal input voltage and full load.
6. Test by minimum Vin and constant resistor load.
7. The ON/OFF control pin voltage is referenced to negative input.
8. See application notes for EMI-filtering.

Package Style and Pinning (mm)

DIP24 Package Style

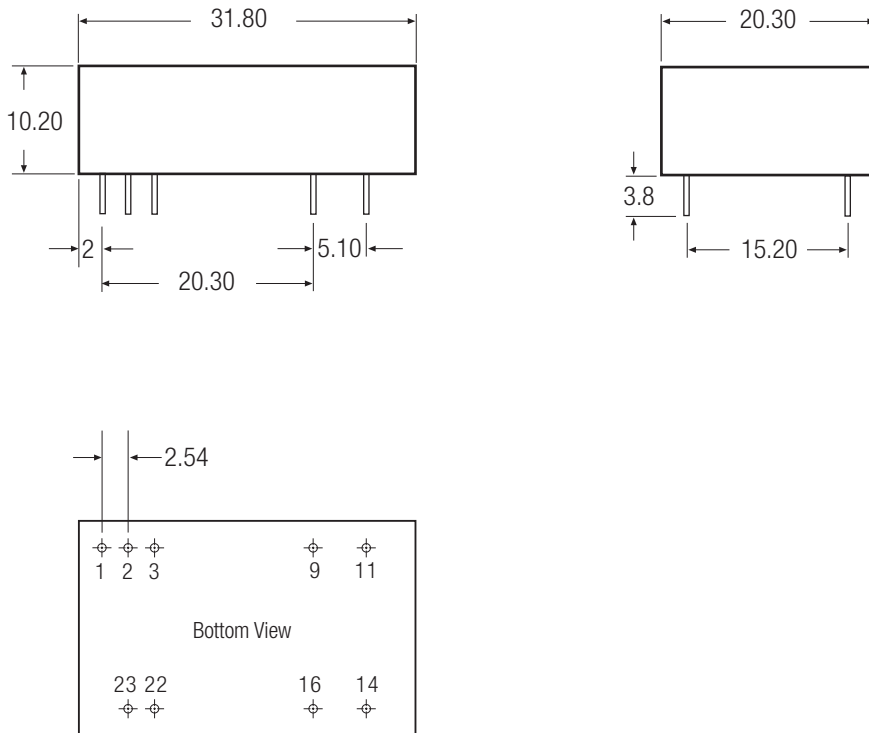

Pin Connections

Pin #	Single	Dual
1	ON/OFF	ON/OFF
2	-Vin	-Vin
3	-Vin	-Vin
9	NC	Com
11	NC	-Vout
14	+Vout	+Vout
16	-Vout	Com
22	+Vin	+Vin
23	+Vin	+Vin

Pin Pitch Tolerance ± 0.35 mm

SMD Package Style and Pinning (mm) (Same sepc. as the original DIP sepc. and pin definition, excl. of the SMD Typ pin.)

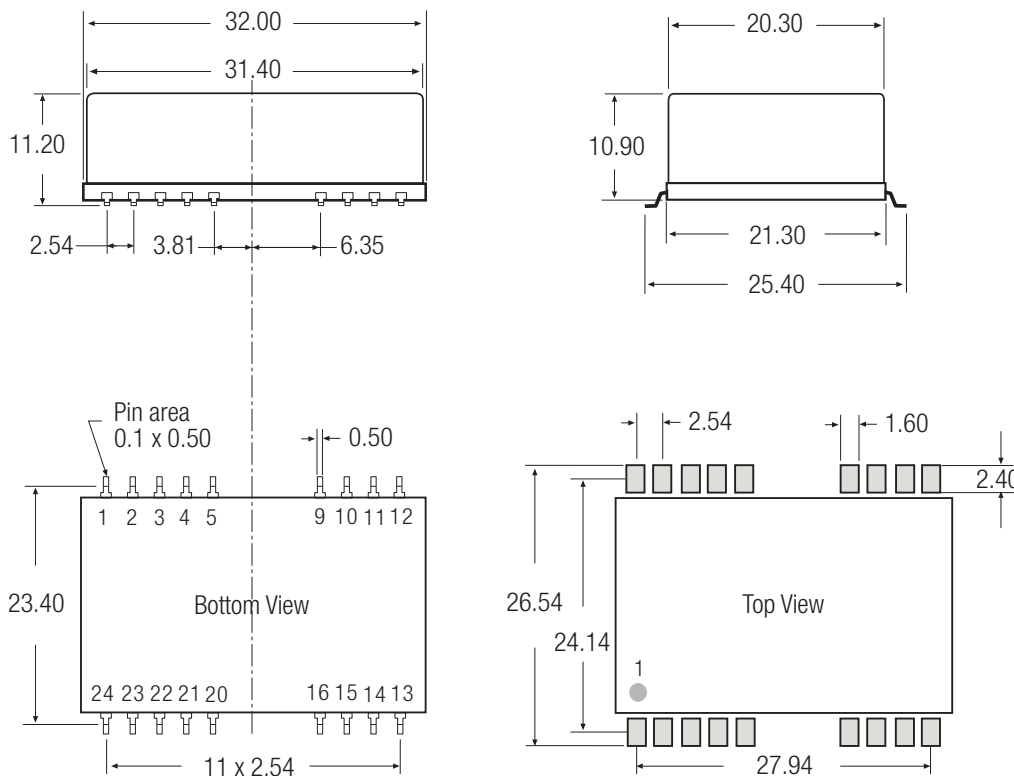

Pin Connections

Pin #	Single	Dual
1	ON/OFF	ON/OFF
2	-Vin	-Vin
3	-Vin	-Vin
9	NC	Com
11	NC	-Vout
14	+Vout	+Vout
16	-Vout	Com
22	+Vin	+Vin
23	+Vin	+Vin
Others	NC	NC

Pin Pitch Tolerance ± 0.35 mm

The product information and specifications are subject to change without prior notice. All products are designed for non-safety critical commercial and industrial applications. The Buyer agrees to implement safeguards that anticipate the consequences of any failures that might cause harm, loss of life and/or damage property.

Features

Regulated Converters

- 4:1 Wide Input Voltage Range
- 12 Watts Regulated Output Power
- 1.6kVDC Isolation
- Over Current and Over Voltage Protection
- Five-Sided Shield
- No Derating to 61°C
- Standard DIP24 Pinning
- Efficiency to 88 %

Description

The RP12-AW series wide range input DC/DC converter are certified to UL 60950-1 and cUL 60950-1. This makes them ideal for all telecom and industrial applications where approved safety standards are required. The DIP24 package is available in both pinned and SMD case styles and meets military standards for thermal shock and vibration tolerance.

Selection Guide 24V and 48V Wide Input Types

Part Number	Input Range VDC	Output Voltage VDC	Output Current mA	Input Current (4,5) mA	Efficiency (6) %	Capacitive (7) Load max.
DIP24 (SMD)						
RP12-243.3SAW**	9-36	3.3	3500	55/602	84	2000µF
RP12-2405SAW**	9-36	5.1	2400	55/614	87	2000µF
RP12-2412SAW**	9-36	12	1000	25/610	86	430µF
RP12-2415SAW**	9-36	15	800	25/610	86	300µF
RP12-483.3SAW**	18-75	3.3	3500	20/301	84	2000µF
RP12-4805SAW**	18-75	5.1	2400	20/307	87	2000µF
RP12-4812SAW**	18-75	12	1000	13/302	87	430µF
RP12-4815SAW**	18-75	15	800	13/298	88	300µF
RP12-2405DAW**	9-36	±5	±1200	20/625	84	±1250µF
RP12-2412DAW**	9-36	±12	±500	25/610	86	±200µF
RP12-2415DAW**	9-36	±15	±400	25/610	86	±120µF
RP12-4805DAW**	18-75	±5	±1200	10/309	85	±1250µF
RP12-4812DAW**	18-75	±12	±500	13/301	87	±200µF
RP12-4815DAW**	18-75	±15	±400	13/301	87	±120µF

** add Suffix SMD for SMD package

POWERLINE

DC/DC-Converter

with 3 year Warranty

RECOM

12 Watt DIP24 & SMD, Single & Dual Output



**UL-60950-1 Certified
E196683**

RP12-AW

Derating Graph (Ambient Temperature)

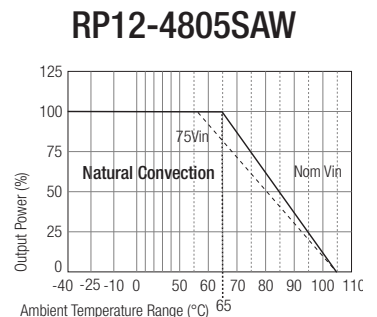

Derating graphs are valid only for the shown part numbers. If you need detailed derating information about a part-number not shown here, please contact our technical support service at: info@recom-development.at

Refer to Application Notes

Specifications (typical at nominal input and 25°C unless otherwise noted)

Input Voltage Range	24V nominal input 48V nominal input	9-36VDC 18-75VDC
Input Filter		Pi Type
Input Surge Voltage (100ms max)		50VDC (24V Type), 100VDC (48V Type)
Input Reflected Ripple (nominal Vin and full load)		20mA _{p-p}
Start Up Time (nominal Vin and constant resistor load)		450ms typ.
Remote ON/OFF ⁽¹⁾	DC-DC ON DC-DC OFF	Open or 3.0V < Vr < 12V Short or 0V < Vr < 1.2V
Remote OFF input current	Nominal input	2.5mA
Output Power		12W max.
Output Voltage Accuracy (full Load and nominal Vin)		±1.2%
Minimum Load		0%
Line Regulation (low line, high line at full load)		±0.2%
Load Regulation (0% to 100% load)		±0.5% Single, ±0.5%
Cross Regulation Dual Output (asymmetric 25% <-> 100% Load)		±5%
Ripple and Noise (20MHz bandwidth, with 1µF MLCC on output)		85mV _{p-p}
Temperature Coefficient		±0.02%/°C max.
Transient Response (25% load step change)		250µs
Input Voltage Variation, dv/dt	complies with ETS300 132, part 4.4	5V/ms
Over Load Protection (% of full load at nominal Vin)		150% typ
Overvoltage Protection (Single)		Zener Diode Clamp
Undervoltage Protection		See Application Notes
Short Circuit Protection		Continuous, automatic recovery
Efficiency		see „Selection Guide“ table
Isolation Voltage (rated for one minute)	In to Out and I/O to case	1600VDC
Isolation Resistance		10 GΩ min.
Isolation Capacitance		1500pF max.
Operating Frequency		400kHz typ.
Operating Temperature Range (No derating)	5.1, 12, 15, ±12, ±15V 3.3, ±5V	-40°C to +65°C -40°C to +61°C
Maximum Case Temperature		+105°C
Storage Temperature Range		-55°C to +125°C
Thermal Impedance	Natural convection	20°C/Watt
Case Material		Nickel plated copper with non-conductive plastic base
Potting Material		Epoxy (UL94-V0)
Weight		18g (DIP), 20g (SMD)
Packing Quantity	Refer to App Notes for tube dimensions	7pcs per Tube
Conducted Emissions ⁽²⁾	EN55022	Class A
Radiated Emissions ⁽²⁾	EN55022	Class A
ESD	EN61000-4-2	Perf. Criteria B
Radiated Immunity	EN61000-4-3	Perf. Criteria A
Fast Transient	EN61000-4-4	Perf. Criteria B

continued on next page

Specifications (typical at nominal input and 25°C unless otherwise noted)

Surge	EN61000-4-5	Pref. Criteria B
Conducted Immunity	EN61000-4-6	Pref. Criteria A
Thermal Shock		MIL-STD-810D
Vibration		10-55Hz, 10G, 30 Min. along X, Y and Z
Relative Humidity		5% to 95% RH
MTMF ⁽²⁾	Bellcore-TR-NWT-000332	2350 x 10 ³ hours

Notes :

1. The ON/OFF control pin voltage is referenced to negative input.
2. BELLCORE TR-NWT-000332. Case I: 50% Stress, Temperature at 40°C (Ground fixed and controlled environment).
3. Requires external filter to meet EN55022 Class A
4. Typical value at nominal input voltage and no load.
5. Maximum value at nominal input voltage and full load
6. Typical value at nominal input voltage and full load.
7. Test by minimum Vin and constant resistor load.

Package Style and Pinning (mm)

DIP24 Package Style

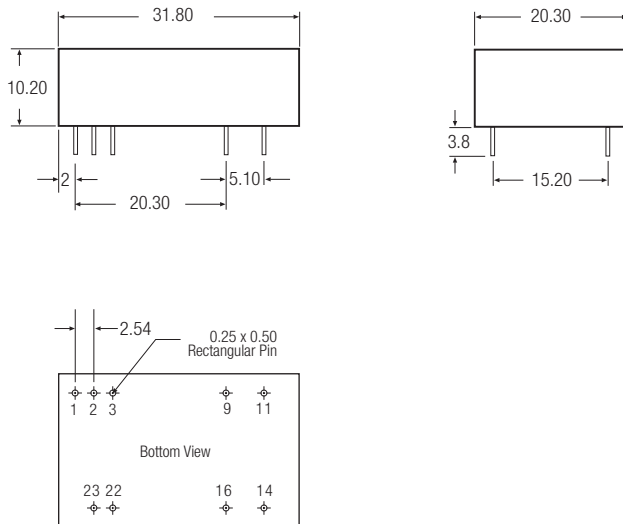

Pin Connections

Pin #	Single	Dual
1	ON/OFF	ON/OFF
2	-Vin	-Vin
3	-Vin	-Vin
9	NC	Com
11	NC	-Vout
14	+Vout	+Vout
16	-Vout	Com
22	+Vin	+Vin
23	+Vin	+Vin

NC = No Connection

Pin Pitch Tolerance ± 0.35 mm

SMD Package Style and Pinning (mm) (Same spec. as the original DIP sepc. and pin definition, excl. of the SMD Typ pin.)

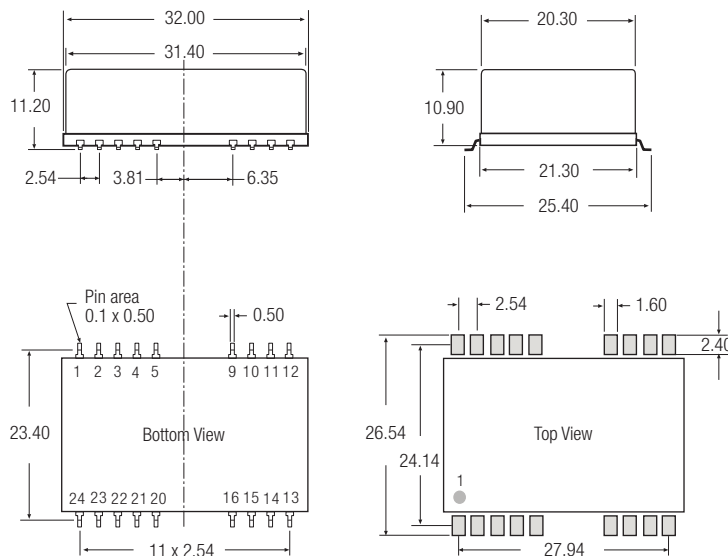

Pin Connections

Pin #	Single	Dual
1	ON/OFF	ON/OFF
2	-Vin	-Vin
3	-Vin	-Vin
9	NC	Com
11	NC	-Vout
14	+Vout	+Vout
16	-Vout	Com
22	+Vin	+Vin
23	+Vin	+Vin
Others	NC	NC

NC = No Connection

Pin Pitch Tolerance ± 0.35 mm

The product information and specifications are subject to change without prior notice. All products are designed for non-safety critical commercial and industrial applications. The Buyer agrees to implement safeguards that anticipate the consequences of any failures that might cause harm, loss of life and/or damage property.

Features

Regulated Converters

- 15 Watts Regulated Output Power
- 2:1 Wide Input Voltage Range
- Six-Sided Shield, meets Class A without external filter
- Standard Pinning
- Remote On/Off Pin
- Fully Protected Outputs
- 1.6kVDC Isolation
- Very Low Quiescent Current
- Efficiency to 91%

Description

The RP15-B series DC/DC converters are high power density converters that offer 15W in the industry standard DIP24 case size with very high efficiency and low quiescent current. The DIP24 package is fully six-sided shielded and meets EN55022 Class A without any external components.

Selection Guide

Part Number	Input Range VDC	Output Voltage VDC	Output Current mA	Input Current mA ⁽²⁾	Efficiency % ⁽³⁾	Capacitive Load max. ⁽⁴⁾
DIP24 (SMD)						
RP15-123.3SB	9-18	3.3	4000	1325/10	87	4700µF
RP15-1205SB	9-18	5.1	3000	1482/10	90	3300µF
RP15-1212SB	9-18	12	1250	1453/5	90	600µF
RP15-1215SB	9-18	15	1000	1453/10	90	400µF
RP15-243.3SB	18-36	3.3	4000	654/6	88	4700µF
RP15-2405SB	18-36	5.1	3000	741/6	90	3300µF
RP15-2412SB	18-36	12	1250	718/4	91	600µF
RP15-2415SB	18-36	15	1000	718/6	91	400µF
RP15-483.3SB	36-75	3.3	4000	327/4	88	4700µF
RP15-4805SB	36-75	5.1	3000	371/4	90	3300µF
RP15-4812SB	36-75	12	1250	363/4	90	600µF
RP15-4815SB	36-75	15	1000	359/4	91	400µF
RP15-1205DB	9-18	±5	±1500	1524/10	86	±1500µF
RP15-1212DB	9-18	±12	±625	1453/6	90	±288µF
RP15-1215DB	9-18	±15	±500	1453/10	90	±200µF
RP15-2405DB	18-36	±5	±1500	753/4	87	±1500µF
RP15-2412DB	18-36	±12	±625	726/6	90	±288µF
RP15-2415DB	18-36	±15	±500	727/6	90	±200µF
RP15-4805DB	36-75	±5	±1500	376/4	87	±1500µF
RP15-4812DB	36-75	±12	±625	363/4	90	±288µF
RP15-4815DB	36-75	±15	±500	363/4	90	±200µF

POWERLINE

DC/DC-Converter

RECOM

15 Watt DIP24 Single & Dual Output



UL-60950-1 Pending

RP15-B

Derating Graph (Ambient Temperature)

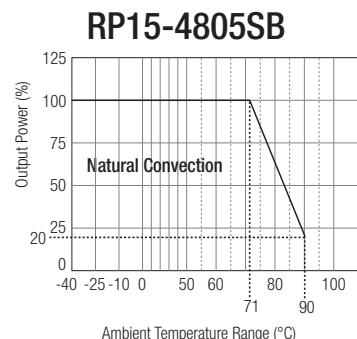

Derating graphs are valid only for the shown part numbers. If you need detailed derating-information about a part-number not shown here please contact our technical support service at info@recom-development.at

Refer to Application Notes

Specifications (typical at nominal input and 25°C unless otherwise noted)

Input Voltage Range ⁽³⁾	12V nominal input	9-18VDC
	24V nominal input	18-36VDC
	48V nominal input	36-75VDC
Input Voltage Undervoltage Lockout	12V nominal input	startup: 9VDC, shutdown: 8VDC
	24V nominal input	startup: 18VDC, shutdown: 16VDC
	48V nominal input	startup: 36VDC, shutdown: 33VDC
Input Filter		PI Type
Input Surge Voltage (100 ms max.)	12V Input	36VDC
	24V Input	50VDC
	48V Input	100VDC
Input Reflected Ripple (nominal Vin and full load)		20mA _{p-p}
Start Up Time (nominal Vin and constant resistor load)		30ms typ.
Remote ON/OFF ⁽⁶⁾	DC-DC ON	Open or 3.0V < Vr < 12V
	DC-DC OFF	Short or 0V < Vr < 1.2V
Remote OFF input current	Nominal input	2.5mA
Output Power		15W max.
Output Voltage Accuracy (full Load and nominal Vin)		±1%
Minimum Load		0%
Line Regulation (low line, high line at full load)	Single	±0.2%
	Dual	±0.5%
Load Regulation	Single (0% to 100% full load)	±0.5%
	Single (10% to 90% full load)	±0.3%
	Dual (0% to 100% full load)	±1%
	Dual (10% to 90% full load)	±0.8%
Cross Regulation (asymmetrical 25%<->100% load)		±5%
Ripple and Noise (20MHz bandwidth limited, with 1µF MLCC on output)		75mV _{p-p}
Temperature Coefficient		±0.02%/°C max.
Transient Response (25% load step change)		250µs
Over Load Protection (% of full load at nominal Vin)		150% typ
Short Circuit Protection		Continuous, automatic recovery
Efficiency		see „Selection Guide“ table
Isolation Voltage (rated for one minute)	Input to Output	1600VDC
	I/O to case	1600VDC
Isolation Resistance		1 GΩ min.
Isolation Capacitance		2000pF max.
Operating Frequency		330kHz typ..
Designed to meet Safety Standards		UL 1950, EN60950
Operating Temperature Range		-40°C to +90°C (with derating)
		-40°C to +71°C (without derating)
Maximum Case Temperature		+105°C
Storage Temperature Range		-55°C to +125°C

continued on next page

Specifications (typical at nominal input and 25°C unless otherwise noted)

Thermal Impedance	Natural convection	20°C/Watt
Thermal Shock		MIL-STD-810F
Vibration		10-55Hz, 10G, 30 Min. along X, Y and Z
Relative Humidity		5% to 95% RH
Case Material		Nickel plated copper
Base Material		Non-conductive black plastic
Potting Material		Silicone (UL94-V0)
Conducted Emissions (without filter)	EN55022	Level A
Conducted Emissions (with filter)	EN55022	Level B
Radiated Emissions	EN55022	Level B
ESD	EN61000-4-2	Perf. Criteria A
Radiated Immunity	EN61000-4-3	Perf. Criteria A
Fast Transient ⁽⁶⁾	EN61000-4-4	Perf. Criteria A
Surge ⁽⁶⁾	EN61000-4-5	Perf. Criteria A
Conducted Immunity	EN61000-4-6	Perf. Criteria A
Weight		14.4g
Packing Quantity	Refer to App Notes for tube dimensions	7 pcs per Tube
Dimensions		31.8 x 20.3 x 10.2mm
MTBF ⁽¹⁾	BELLCORE TR-NWT-000332	3378 x 10 ³ hours
	MIL-HDBK-217F	4645 x 10 ³ hours

Notes:

1. BELLCORE TR-NWT-000332. Case I: 50% Stress, Temperature at 40°C (Ground fixed and controlled environment). MIL-HDBK-217F, Notice 2, Full Load, 25°C, Ground Benign.
2. Full Load/No Load input current at Nominal Vin.
3. Typical value at nominal input voltage and full load.
4. Test by minimum Vin and constant resistor load.
5. The ON/OFF control pin voltage is referenced to negative input.
6. Requires external capacitor to meet EN61000-4-4, -5: Recom suggests Nippon Chemicon KY series, 220µF/100V, ESR=48mOhm)

Typical Performance Graph

RP15-4805SB

Efficiency VS Output load

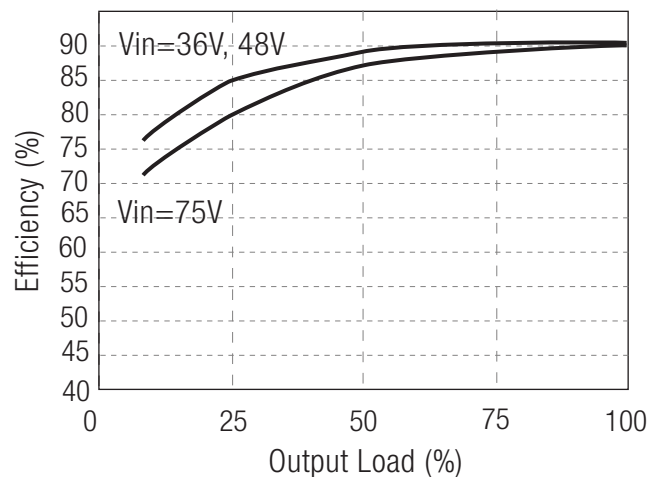

Package Style and Pinning (mm)

DIP24 Package Style

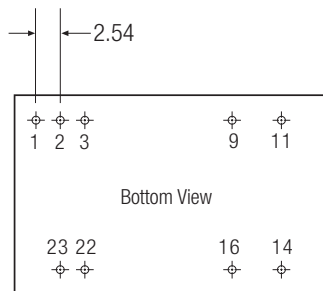
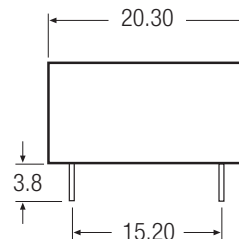
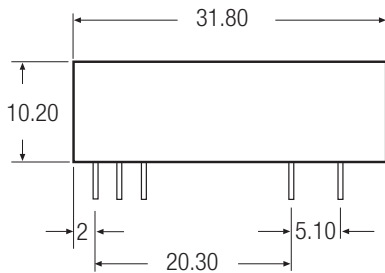

Pin Connections

Pin #	Single	Dual
1	ON/OFF	ON/OFF
2	-Vin	-Vin
3	-Vin	-Vin
9	NC	Com
11	NC	-Vout
14	+Vout	+Vout
16	-Vout	Com
22	+Vin	+Vin
23	+Vin	+Vin

NC = No Connection

Pin Pitch Tolerance ± 0.35 mm

Features

Regulated Converters

- 15 Watts Regulated Output Power
- 4:1 Wide Input Voltage Range
- Six-Sided Shield, meets Class A without external filter
- Standard Pinning
- Remote On/Off Pin
- Fully Protected Outputs
- 1.6kVDC Isolation
- Very Low Quiescent Current
- Efficiency to 90%

Description

The RP15-B series DC/DC converters are high power density converters that offer 15W in the industry standard DIP24 case size with very high efficiency and low quiescent current. The DIP24 package is fully six-sided shielded and meets EN55022 Class A without any external components.

Selection Guide

Part Number	Input Range VDC	Output Voltage VDC	Output Current mA	Input Current mA ⁽²⁾	Efficiency ⁽³⁾ %	Capacitive Load max. ⁽⁴⁾
DIP24 (SMD)						
RP15-243.3SBW	9-36	3.3	4000	654/6	88	4700µF
RP15-2405SBW	9-36	5.1	3000	741/6	90	3300µF
RP15-2412SBW	9-36	12	1250	726/6	90	600µF
RP15-2415SBW	9-36	15	1000	726/6	90	400µF
RP15-483.3SBW	18-75	3.3	4000	323/4	89	4700µF
RP15-4805SBW	18-75	5.1	3000	375/4	89	3300µF
RP15-4812SBW	18-75	12	1250	363/4	90	600µF
RP15-4815SBW	18-75	15	1000	363/4	90	400µF
RP15-2405DBW	9-36	±5	±1500	762/6	86	±1500µF
RP15-2412DBW	9-36	±12	±625	735/6	89	±288µF
RP15-2415DBW	9-36	±15	±500	726/6	90	±200µF
RP15-4805DBW	18-75	±5	±1500	381/4	86	±1500µF
RP15-4812DBW	18-75	±12	±625	368/4	89	±288µF
RP15-4815DBW	18-75	±15	±500	363/4	90	±200µF

POWERLINE

AC/DC-Converter

with 3 year Warranty

RECOM

15 Watt

DIP24

Single &

Dual Output



UL-60950-1 Pending

RP15-BW

Derating Graph

(Ambient Temperature)

RP15-4805SBW

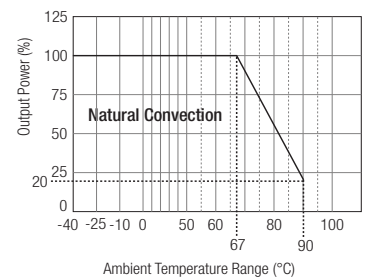

Derating graphs are valid only for the shown part numbers. If you need detailed derating-information about a part-number not shown here please contact our technical support service at info@recom-development.at

Refer to Application Notes

Specifications (typical at nominal input and 25°C unless otherwise noted)

Input Voltage Range ⁽⁹⁾	24V nominal input	9-36VDC
	48V nominal input	18-75VDC
Input Voltage Undervoltage Lockout	24V nominal input	startup: 9VDC, shutdown: 8VDC
	48V nominal input	startup: 18VDC, shutdown: 16VDC
Input Filter		PI Type
Input Surge Voltage (1s max.)	24V Input	50VDC
	48V Input	100VDC
Input Reflected Ripple (nominal Vin and full load)		20mAp-p
Start Up Time (nominal Vin and constant resistor load)		30ms typ.
Remote ON/OFF ⁽⁹⁾	DC-DC ON	Open or 3.0V < Vr < 12V
	DC-DC OFF	Short or 0V < Vr < 1.2V
Remote OFF input current	Nominal input	2.5mA
Output Power		15W max.
Output Voltage Accuracy (full Load and nominal Vin)		±1%
Minimum Load		0%
Line Regulation (low line, high line at full load)		±0.2%
Load Regulation	Single (0% to 100% full load)	±0.5%
	Single (10% to 90% full load)	±0.3%
	Dual (0% to 100% full load)	±1%
	Dual (10% to 90% full load)	±0.8%
Cross Regulation (asymmetrical 25%<->100% load)		±5%
Ripple and Noise (20MHz bandwidth limited, with 1µF MLCC on output)		60mVp-p
Temperature Coefficient		±0.02%/°C max.
Transient Response (25% load step change)		250µs
Over Load Protection (% of full load at nominal Vin)		150% typ
Short Circuit Protection		Continuous, automatic recovery
Efficiency		see „Selection Guide“ table
Isolation Voltage (rated for one minute)	Input to Output	1600VDC
	I/O to case	1600VDC
Isolation Resistance		1 GΩ min.
Isolation Capacitance		2000pF max.
Operating Frequency		330kHz typ.
Designed to meet Safety Standards		UL 60950-1, EN60950-1
Operating Temperature Range		-40°C to +100°C (with derating)
		-40°C to +67°C (without derating)
Maximum Case Temperature		+105°C
Storage Temperature Range		-55°C to +125°C
Thermal Impedance	Natural convection	20°C/Watt
Thermal Shock		MIL-STD-810F
Vibration		10-55Hz, 10G, 30 Min. along X, Y and Z
Relative Humidity		5% to 95% RH

continued on next page

Specifications (typical at nominal input and 25°C unless otherwise noted)

Case Material		Nickel plated copper
Base Material		FR4
Potting Material		Silicone (UL94-V0)
Conducted Emissions (without filter)	EN55022	Level A
Conducted Emissions (with filter)	EN55022	Level B
Radiated Emissions	EN55022	Level B
ESD	EN61000-4-2	Perf. Criteria A
Radiated Immunity	EN61000-4-3	Perf. Criteria A
Fast Transient ⁽⁶⁾	EN61000-4-4	Perf. Criteria A
Surge ⁽⁶⁾	EN61000-4-5	Perf. Criteria A
Conducted Immunity	EN61000-4-6	Perf. Criteria A
Weight		14.4g
Packing Quantity	Refer to App Notes for tube dimensions	7 pcs per Tube
Dimensions		31.8 x 20.3 x 10.2mm
MTBF ⁽¹⁾	BELLCORE TR-NWT-000332	3374 x 10 ³ hours
	MIL-HDBK-217F	4135 x 10 ³ hours

Notes:

1. BELLCORE TR-NWT-000332. Case I: 50% Stress, Temperature at 40°C (Ground fixed and controlled environment). MIL-HDBK-217F, Notice 2, Full Load, 25°C, Ground Benign.
2. Full Load/No Load input current at Nominal Vin.
3. Typical value at nominal input voltage and full load.
4. Test by minimum Vin and constant resistor load.
5. The ON/OFF control pin voltage is referenced to negative input.
6. Requires external capacitor to meet EN61000-4-4, -5: Recom suggests Nippon Chemicon KY series, 220µF/100V, ESR=48mOhm)

Typical Performance Graphs

RP15-4805SBW

Efficiency VS Input Voltage

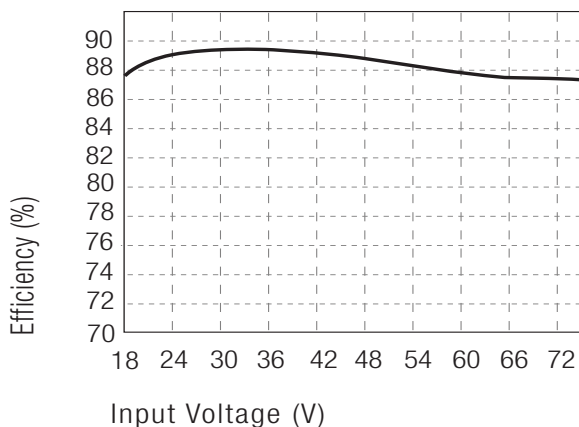

Efficiency VS Output load

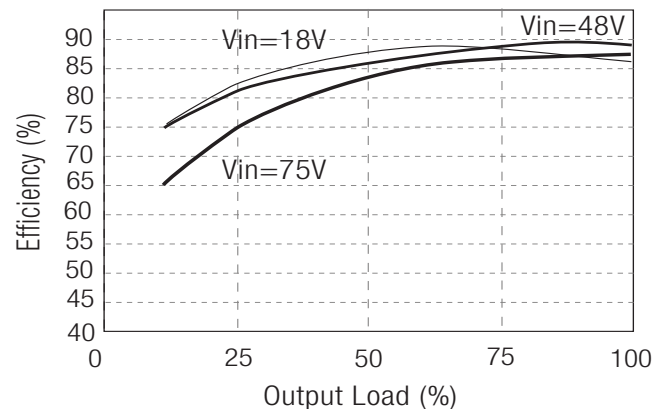

POWERLINE

DC/DC-Converter

RP15-S_DBW Series

Package Style and Pinning (mm)

DIP24 Package Style

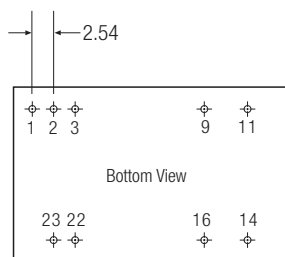
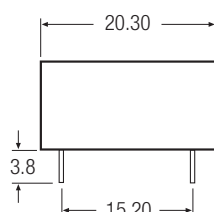
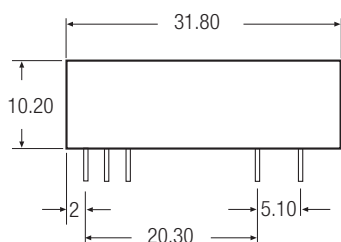

Pin Connections

Pin #	Single	Dual
1	ON/OFF	ON/OFF
2	-Vin	-Vin
3	-Vin	-Vin
9	NC	Com
11	NC	-Vout
14	+Vout	+Vout
16	-Vout	Com
22	+Vin	+Vin
23	+Vin	+Vin

NC = No Connection

Pin Pitch Tolerance ± 0.35 mm

Features

- Ultraminiature Open Frame SMD
- 15 Watts Output Power
- 2:1 Input Voltage Range
- Single Outputs
- 2.25kVDC Isolation
- Fixed Operating Frequency
- Optional Remote On/Off and Trim pins
- Efficiency to 88%

Description

The RP15-SOF series are SMD open frame ultraminiature power DC/DC converters in a case half the size of industry standard 15W converters. The converters use solder ball pins to enable SMD mounting and can be reflow soldered.

Despite their small size, these converters are fully specified devices with output currents up to 3.5 Amps, no minimum load, 2250VDC isolation and low ripple/noise figures.

The outputs are also fully protected against short circuits, overcurrent and overvoltage. The RP15-SOF series will find many uses in telecommunications and other demanding applications where cost, board space or board height is at a premium.

Selection Guide 24V and 48V Input Types

Part Number	Input Range VDC	Output Voltage VDC	Output Current mA	Input ⁽¹⁾ Current mA	Efficiency ⁽²⁾ %	Capacitive ⁽³⁾ Load max.
RP15-243.3SOF**	18-36	3.3	3500	20/587	86	1000µF
RP15-2405SOF**	18-36	5	3000	20/753	87	1000µF
RP15-2412SOF**	18-36	12	1250	15/753	87	330µF
RP15-2415SOF**	18-36	15	1000	15/744	88	220µF
RP15-483.3SOF**	36-75	3.3	3500	15/297	85	1000µF
RP15-4805SOF**	36-75	5	3000	15/377	87	1000µF
RP15-4812SOF**	36-75	12	1250	10/377	87	330µF
RP15-4815SOF**	36-75	15	1000	10/372	88	220µF

** Standard part is without suffixes and trim and CTRL pins are not fitted.

* add suffix /P for CTRL function with positive logic (1=ON, 0=OFF) including trim pin for single output

* add suffix /N for CTRL function with negative logic (0=ON, 1=OFF) including trim pin for single output

Ordering Examples

RP15-2405SOF = 24 Input, 5V Output, No CTRL or trim connections

RP15-2412SOF/P = 24V Input, 12V Output, Positive logic. CTRL and trim SMD pins fitted

POWERLINE

DC/DC-Converter

with 3 year Warranty

RECOM

15 Watt Single Output Open Frame SMD



**UL-60950-1 Certified
E196683**

RP15-SOF

Derating Graph (Ambient Temperature)

RP15-4805SOF

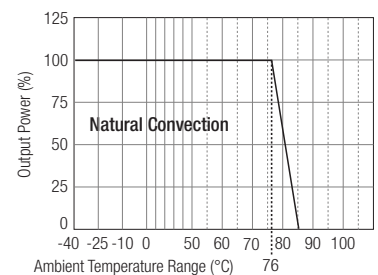

Derating graphs are valid only for the shown part number. If you need detailed derating information about a part number not shown here please contact our technical support service at info@recom-development.at

Refer to Application Notes

Specifications (typical at nominal input and 25°C unless otherwise noted)

Input Voltage Range	24V nominal input	18-36VDC
	48V nominal input	36-75VDC
Input Filter		Pi Type
Input Surge Voltage (100 ms max.)	24V Input	50VDC
	48V Input	100VDC
Input Reflected Ripple (nominal Vin and full load) ⁽⁴⁾		30mA _{p-p} typ.
Start Up Time (nominal Vin and constant resistor load)		30ms max.
Optional Remote ON/OFF ⁽⁵⁾	DC-DC ON	Short or 0V < Vr < 1.2V
Negative logic (/N)	DC-DC OFF	Open or 3.0V < Vr < 15V
	DC-DC ON	Open or 3.0V < Vr < 15V
Positive logic (/P)	DC-DC OFF	Short or 0V < Vr < 1.2V
Remote Pin drive current	Nominal Vin	-0.5mA~1.0mA
Remote OFF input current	Nominal Vin	20mA max.
Output Voltage Accuracy (full Load and nominal Vin)		±1%
Optional Output Trim ⁽⁵⁾		±10%
Minimum Load		0%
Line Regulation (low line, high line at full load)	Single	±0.2%
Load Regulation (0% to full load)	Single	±0.2%
Ripple and Noise (20MHz bandwidth, with 1µF MLCC on output)	3.3, 5V Outputs	75mV _{p-p}
	Others	100mV _{p-p}
Temperature Coefficient		±0.02%/°C max.
Transient Response	25% load step change	250µs
Over Voltage Protection	3.3V	3.7-5.4V
Zener diode clamp (only single)	5V	5.4-7.0V
	12V	13.5-19.6V
	15V	16.8-20.5V
Over Load Protection (% of full load at nominal Vin)		150% typ
Undervoltage Lockout		See Application Notes
Short Circuit Protection		Hiccup, automatic recovery
Efficiency		see „Selection Guide“ table
Isolation Voltage (rated for one minute)	Basic Isolation	2225VDC
Isolation Resistance		1 GΩ min.
Isolation Capacitance		1000pF typ.
Operating Frequency	3.3V , 5V	270kHz typ.
	All others	400kHz typ.
Operating Temperature Range		-40°C to +85°C (with derating)
Storage Temperature Range		-55°C to +125°C
Thermal Shock		MIL-STD-810F
Vibration		10-55Hz, 2G, 30 Min. along X, Y and Z
Relative Humidity		5% to 95% RH
Base Material		FR4 PCB
Weight		10.5g

continued on next page

Specifications (typical at nominal input and 25°C unless otherwise noted)

Packing Quantity	Refer to App Notes for tube dimensions	20 pcs per Tube 120 pcs per Reel
Dimensions		27.9 x 23.9 x 8.5mm
Conducted Emissions ⁽⁶⁾	EN55022	Class A/B
Radiated Emissions	EN55022	Class A/B
Radiated Immunity	EN61000-4-3	Perf. Criteria A
Fast Transient ⁽⁷⁾	EN61000-4-4	Perf. Criteria A
Surge ⁽⁷⁾	EN61000-4-5	Perf. Criteria A
Conducted Immunity	EN61000-4-6	Perf. Criteria A
MTBF ⁽⁸⁾	Bellcore TR-NWT-000332 MIL-HDBK 217F	2200 x 10 ³ hours 1314 x 10 ³ hours

EMC Filtering - For Class B filter suggestion, see Application Notes

Class A Filter

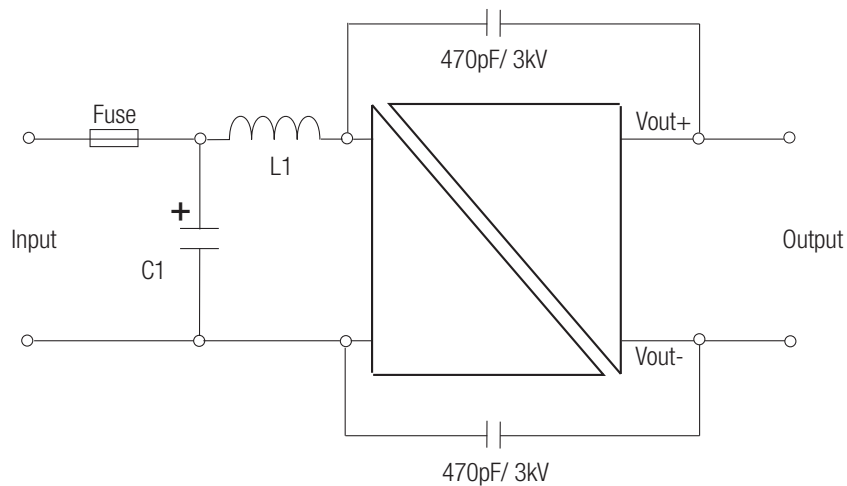

Vin=24V: C1=6.8µF/50V 1812 MLCC, L1 = 10µH, 1.4A, 100mOhm, 0504 SMD
 Vin=48V: C1= 2.2µF/100V 1812 MLCC, L1 = 10µH, 1.4A, 100mOhm, 0504 SMD

Notes :

1. Values at nominal input voltage and no load/full load.
2. Typical Value at nominal input voltage and full load.
3. Test by minimum Vin and constant resistor load.
4. Simulated source impedance of 12µH. 12µH inductor in series with +Vin.
5. If no suffix is specified, the control pin will be omitted. If fitted, the ON/OFF control function can be positive or negative logic. The pin voltage is referenced to negative input.
 Positive logic ON/OFF is marked with suffix-P (eg. RP15-2405SOF/P).
 Negative logic ON/OFF is marked with suffix-N (eg. RP15-2405SOF/N).
6. Meets Class A with external components shown above. Will meet Class B with external common mode filter (see Application Notes)
7. Requires external capacitor to meet EN61000-4-5: 220µF/100V, low ESR (48mOhm)
8. BELLCORE TR-NWT-000332. Case I: 50% Stress, Temperature at 40°C.
 MIL-HDBK 217F Notice 2. Ta = 25°C, full load, (Ground, Benign, controlled environment).

Typical Characteristics

RP15-4805SOF

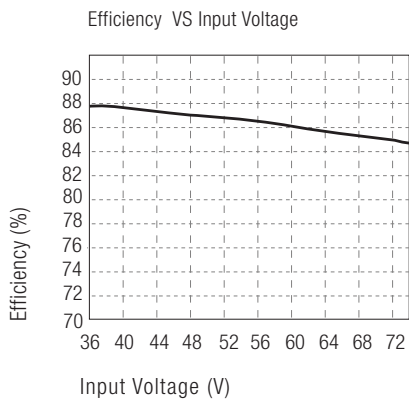

RP15-4805SOF

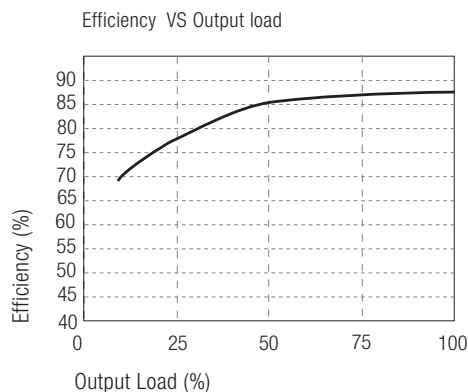

Package Style and Pinning (mm)

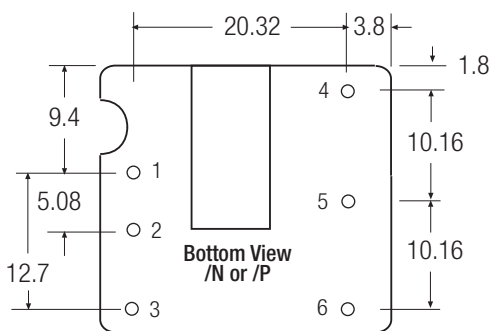
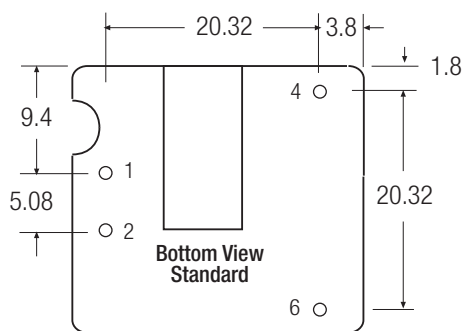
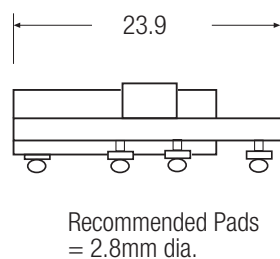
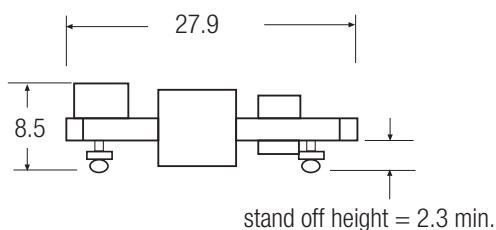

Pin Connections

Pin #	Standard	/P or /N
1	+Vin	+Vin
2	-Vin	-Vin
3	no pin	CTRL
4	+Vout	+Vout
5	no pin	Trim
6	-Vout	-Vout

PCB Tolerance ± 0.5 mm
SMD Pin Pitch Tolerance ± 0.25 mm

External Output Trimming (optional)

With suffix /P or /N, the output can be externally trimmed by using the method shown here. See Application Notes for details

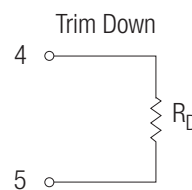
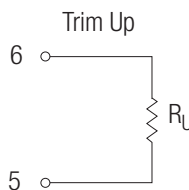

Features

- Ultraminiature Open Frame SMD
- 15 Watts Output Power
- 4:1 Input Voltage Range
- Single Output
- 2.25kVDC Isolation
- Fixed Operating Frequency
- Optional Remote On/Off and Trim pins
- Efficiency to 87%

Description

The RP15-SOFW series are SMD open frame ultraminiature power DC/DC converters in a case half the size of industry standard 15W converters. The converters use solder ball pins to enable SMD mounting and can be reflow soldered. Despite their small size, the RP15-SOFW converters are fully specified devices with output currents up to 4 Amps, no minimum load, 2250VDC isolation and low ripple/noise figures. The outputs are also fully protected against short circuits, overcurrent and overvoltage. The RP15-SOFW series will find many uses in telecommunications and other demanding applications where price, board space or board height is at a premium.

Selection Guide 24V and 48V Input Types

Part Number	Input Range VDC	Output Voltage VDC	Output Current mA	Input (1) Current mA	Efficiency (2) %	Capacitive (3) Load max.
RP15-243.3SOFW**	9-36	3.3	4000	60/680	85	1000µF
RP15-2405SOFW**	9-36	5	3000	70/754	87	1000µF
RP15-2412SOFW**	9-36	12	1300	10/793	86	330µF
RP15-2415SOFW**	9-36	15	1000	10/763	86	220µF
RP15-483.3SOFW**	18-75	3.3	4000	40/340	85	1000µF
RP15-4805SOFW**	18-75	5	3000	40/377	87	1000µF
RP15-4812SOFW**	18-75	12	1300	10/397	86	330µF
RP15-4815SOFW**	18-75	15	1000	10/382	86	220µF

** Standard part is without suffix and has no Trim or CTRL connections

* add suffix **/P** for CTRL function with positive logic (1=ON, 0=OFF) including trim pin

* add suffix **/N** for CTRL function with negative logic (0=ON, 1=OFF) including trim pin

. * add suffix **-R** for Tape and Reel Packaging

Ordering Examples

RP15-4805SOFW = 48V 4:1 Input, 5V Output, No CTRL pin, No Trim Pin

RP15-4805SOFW/P = 48V 4:1 Input, 5V Output, Positive Logic CTRL pin and Trim pin fitted.

RP15-243.3SOFW/N = 24V 4:1 Input, 3.3V Output, Negative Logic CTRL pin and Trim pin fitted

POWERLINE

DC/DC-Converter

with 3 year Warranty

RECOM

15 Watt

Single

Output

Open Frame

SMD



UL-60950-1 Certified
E196683

RP15-SOFW

Derating Graph

(Ambient Temperature)

RP15-4805SOFW

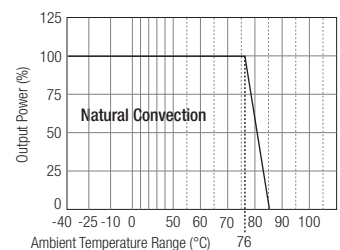

Derating graphs are valid only for the shown part numbers. If you need detailed derating information about a part-number not shown here please contact our technical support service at info@recom-development.at

Refer to Application Notes

Specifications (typical at nominal input and 25°C unless otherwise noted)

Input Voltage Range	24V nominal input 48V nominal input	9-36VDC 18-75VDC
Input Filter		Pi Type
Input Surge Voltage (100 ms max.)	24V Input 48V Input	50VDC 100VDC
Input Reflected Ripple (nominal Vin and full load) ⁽⁴⁾		30mA _{p-p}
Start Up Time (nominal Vin and constant resistor load)		30ms max.
Optional Remote ON/OFF ⁽⁵⁾	DC-DC ON	Short or 0V < Vr < 1.2V
Negative logic (/N)	DC-DC OFF	Open or 3.0V < Vr < 15V
Positive logic (/P)	DC-DC ON	Open or 3.0V < Vr < 15V
Remote Pin drive current	DC-DC OFF	Short or 0V < Vr < 1.2V
Remote OFF input current	Nominal Vin	-0.5mA~1.0mA
	Nominal Vin	2.5mA
Output Voltage Accuracy (full Load and nominal Vin)		±1%
Optional Output Trim ⁽⁶⁾		±10%
Minimum Load		0%
Line Regulation (low line, high line at full load)	All Output voltages	±0.2%
Load Regulation (0% to full load)	All Output voltages	±0.2%
Ripple and Noise (20MHz bandwidth, with 1µF MLCC on output)	All Output voltages	100mV _{p-p}
Temperature Coefficient		±0.02%/°C max.
Transient Response (25% load step change)		250µs
Over Voltage Protection	3.3V	3.7-5.4V
Zener diode clamp (only single)	5V	5.4-7.0V
	12V	13.5-19.6V
	15V	16.8-20.5V
Over Load Protection (% of full load at nominal Vin)		150% typ
Undervoltage Lockout		See Application Notes
Short Circuit Protection		Hiccup, automatic recovery
Efficiency		see „Selection Guide“ table
Isolation Voltage (rated for one minute)	Basic Isolation	2250VDC
Isolation Resistance		1 GΩ min.
Isolation Capacitance		1500pF max.
Operating Frequency	3.3V, 5V All others	350kHz typ 400kHz typ
Operating Temperature Range		-40°C to +85°C (with derating)
Storage Temperature Range		-55°C to +125°C
Thermal Impedance	Natural convection	18.2°C/Watt
Thermal Shock		MIL-STD-810F
Vibration		10-55Hz, 2G, 30 Min. along X, Y and Z
Relative Humidity		5% to 95% RH
Base Material		FR4 PCB
Weight		10.5g
Packing Quantity	Refer to App Notes for tube dimensions	20 pcs per Tube 120 pcs per Reel
Dimensions		27.9 x 23.9 x 8.5mm

continued on next page

Specifications (typical at nominal input and 25°C unless otherwise noted)

Conducted Emissions ⁽⁶⁾	EN55022	Class A/B
Radiated Emissions	EN55022	ClassB
Radiated Immunity	EN61000-4-3	Perf. Criteria A
Fast Transient ⁽⁷⁾	EN61000-4-4	Perf. Criteria A
Surge ⁽⁷⁾	EN61000-4-5	Perf. Criteria A
Conducted Immunity	EN61000-4-6	Perf. Criteria A
MTBF ⁽⁸⁾	Bellcore TR-NWT-000332	1322 x 10 ³ hours
	MIL-HDBK 217F	515 x 10 ³ hours

EMC Filtering - For Class B filter suggestion, see Application Notes

Class A Filter

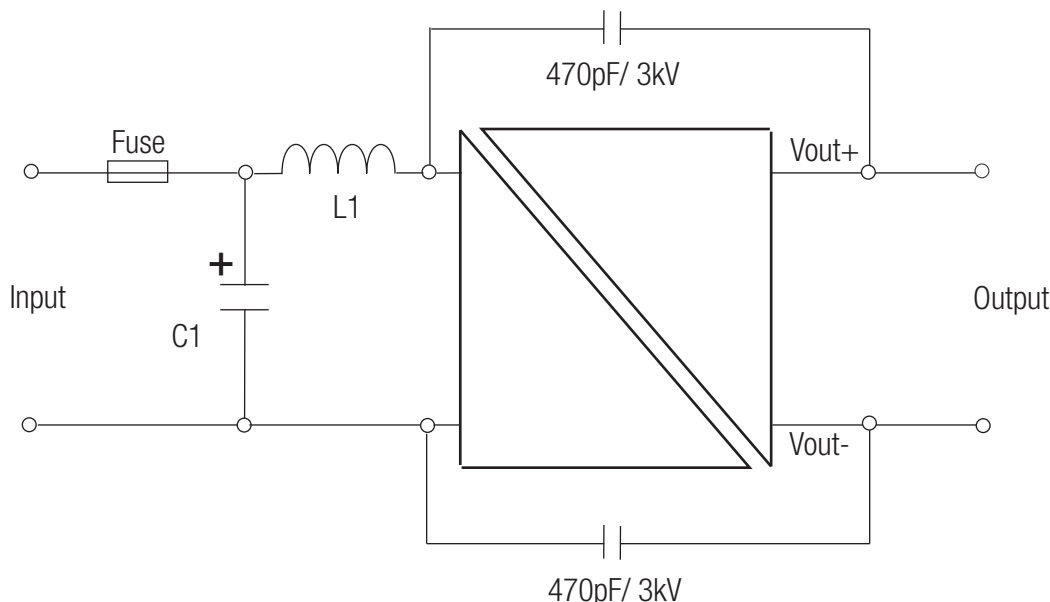

Vin=24V: C1=6.8µF/50V 1812 MLCC, L1 = 10µH, 2.6A, 40mOhm, 0705 SMD
 Vin=48V: C1= 2.2µF/100V 1812 MLCC, L1 = 18µH, 1.6A, 10hm, 0705 SMD

Notes :

1. Values at nominal input voltage and no load/full load.
2. Typical Value at nominal input voltage and full load.
3. Test by minimum Vin and constant resistor load.
4. Simulated source impedance of 12µH. 12µH inductor in series with +Vin.
5. If no suffix is specified, the control and trim pins will be omitted. If fitted, the ON/OFF control function can be positive or negative logic. The pin voltage is referenced to negative input.
 Positive logic ON/OFF is marked with suffix-P (eg. RP15-2405SOFW/P)
 Negative logic ON/OFF is marked with suffix-N (eg. RP15-2405SOFW/N).
6. Meets Class A with external components shown above. Will meet Class B with external common mode filter (see Application Notes)
7. Requires external capacitor to meet EN61000-4-4_5: 220µF/100V, low ESR (48mOhm)
8. BELLCORE TR-NWT-000332. Case I: 50% Stress, Temperature at 40°C.
 MIL-HDBK 217F Notice 2. Ta = 25°C, full load, (Ground Benign, controlled environment).

Typical Characteristics

RP15-4805SOFW

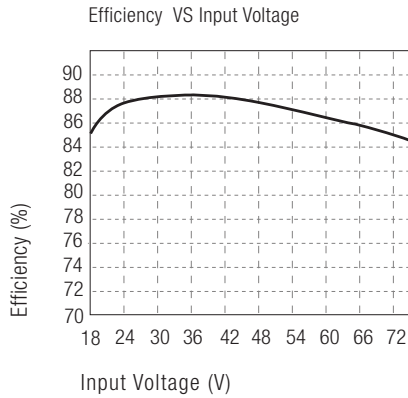

RP15-4805SOFW

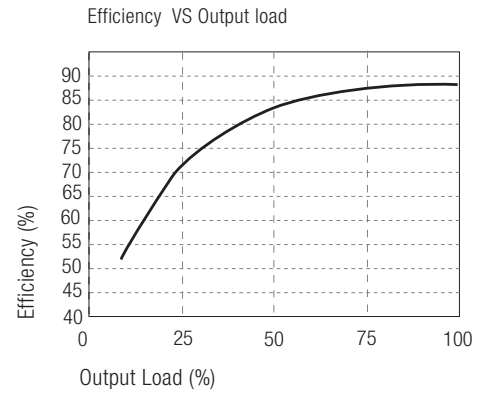

Package Style and Pinning (mm)

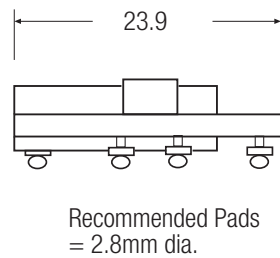
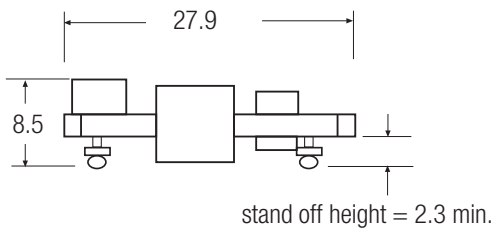

Pin Connections

Pin #	Standard	/P or /N
1	+Vin	+Vin
2	-Vin	-Vin
3	no pin	CTRL
4	+Vout	+Vout
5	no pin	Trim
6	-Vout	-Vout

PCB Tolerance ± 0.5 mm
SMD Pin Pitch Tolerance ± 0.25 mm

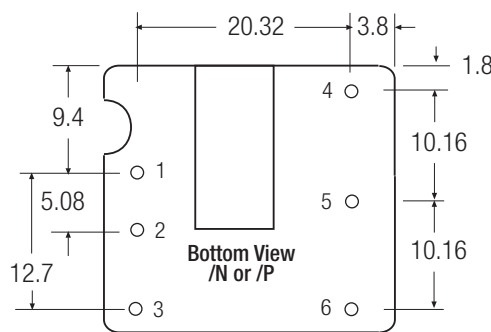
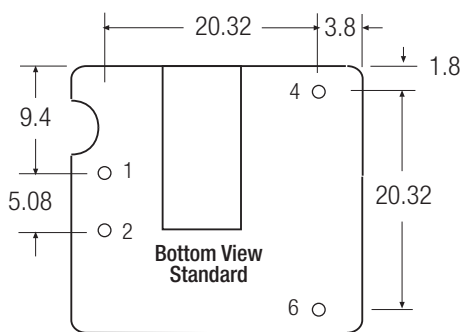

External Output Trimming (optional)

With /P or /N suffix, output can be externally trimmed by using the method shown here. See Application Notes for details.

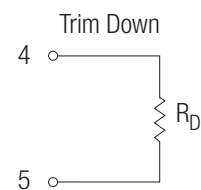
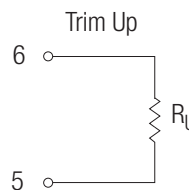

Features

- Ultraminiature 25.4 x25.4x9.9mm Package
- 15 Watts Output Power
- Single and Dual Outputs
- 1.6kVDC Isolation
- Fixed Operating Frequency
- Six-Sided Continuous Shield
- Industry Standard Pinout
- Remote On/Off and Trim pins
- Efficiency to 89%

Description

The RP15-SA series are ultraminiature power DC/DC converters in a case half the size of industry standard 15W converters. Despite their small size, the RP15-SA converters are fully specified devices with output currents up to 4 Amps, no minimum load, 1600VDC isolation and low ripple/noise figures. The outputs are also fully protected against short circuits, overcurrent and overvoltage.

The RP15-SA series will find many uses in applications where board space and/or board height is at a premium.

Selection Guide 24V and 48V Input Types

Part Number	Input Range VDC	Output Voltage VDC	Output Current mA	Input Current mA	Efficiency ⁽²⁾ %	Capacitive ⁽³⁾ Load max.
RP15-123.3SA**	9-18	3.3	4000	120/1375	84	1000µF
RP15-1205SA**	9-18	5	3000	90/1524	86	1000µF
RP15-1212SA**	9-18	12	1300	40/1605	85	330µF
RP15-1215SA**	9-18	15	1000	40/1506	87	220µF
RP15-243.3SA**	18-36	3.3	4000	50/671	86	1000µF
RP15-2405SA**	18-36	5	3000	65/763	86	1000µF
RP15-2412SA**	18-36	12	1300	20/783	87	330µF
RP15-2415SA**	18-36	15	1000	20/744	88	220µF
RP15-483.3SA**	36-75	3.3	4000	40/336	86	1000µF
RP15-4805SA**	36-75	5	3000	40/372	88	1000µF
RP15-4812SA**	36-75	12	1300	15/387	88	330µF
RP15-4815SA**	36-75	15	1000	15/372	88	220µF
RP15-1205DA**	9-18	±5	±1500	30/1543	85	±500µF
RP15-1212DA**	9-18	±12	±625	30/1506	87	±150µF
RP15-1215DA**	9-18	±15	±500	30/1488	87	±100µF
RP15-2405DA**	18-36	±5	±1500	20/772	85	±500µF
RP15-2412DA**	18-36	±12	±625	15/744	88	±150µF
RP15-2415DA**	18-36	±15	±500	25/744	88	±100µF
RP15-4805DA**	36-75	±5	±1500	15/386	85	±500µF
RP15-4812DA**	36-75	±12	±625	15/368	89	±150µF
RP15-4815DA**	36-75	±15	±500	20/372	88	±100µF

** Standard part is without suffixes and Trim and CTRL pins are not fitted.

* add suffix /P for CTRL function with positive logic (1=ON, 0=OFF) including trim pin for single output

* add suffix /N for CTRL function with negative logic (0=ON, 1=OFF) including trim pin for single output

* add suffix -HC for premounted heatsink and clips

Ordering Examples

RP15-2405SA/P = 24V Input, 5V Output, Positive Logic CTRL pin and Trim pin fitted

RP15-4805DA-HC = 48V nput, ±5V Output, Heatsink fitted

Derating graphs are valid only for the shown part numbers. If you need detailed derating-information about a part-number not shown here please contact our technical support service at info@recom-development.at

POWERLINE

DC/DC-Converter

with 3 year Warranty

RECOM

15 Watt Single & Dual Output



**UL-60950-1 Certified
E196683**

RP15-A

Derating Graph (Ambient Temperature)

RP15-4805SA

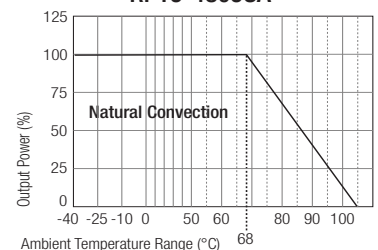

RP15-4805SA With Heat Sink

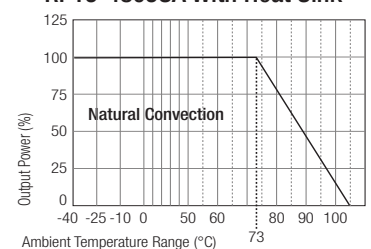

Refer to Application Notes

Specifications (typical at nominal input and 25°C unless otherwise noted)

Input Voltage Range	12V nominal input	9-18VDC
	24V nominal input	18-36VDC
	48V nominal input	36-75VDC
Input Filter		Pi Type
Input Surge Voltage (100 ms max.)	12V Input	36VDC
	24V Input	50VDC
	48V Input	100VDC
Input Reflected Ripple (nominal Vin and full load) ⁽⁴⁾		30mA _{p-p}
Start Up Time (nominal Vin and constant resistor load)		30ms max.
Optional Remote ON/OFF ⁽⁵⁾ (Negative logic)	DC-DC ON	Short or 0V < Vr < 1.2V
	DC-DC OFF	Open or 3.0V < Vr < 12V
Remote Pin drive current	Nominal Vin	-0.5mA~1.0mA
Remote OFF input current	Nominal Vin	2.5mA
Output Voltage Accuracy (full Load and nominal Vin)		±1%
Optional Output Trim ⁽⁶⁾		±10%
Minimum Load		0%
Line Regulation (low line, high line at full load)	Single	±0.2%
	Dual	±0.5%
Load Regulation (0% to full load)	Single	±0.2%
	Dual	±1%
Cross Regulation (Asymmetrical 25% <>100% load)	Dual Output	±5%
Ripple and Noise (20MHz bandwidth, with 1µF MLCC on output)	3.3, 5V Outputs	75mV _{p-p}
	Others	100mV _{p-p}
Temperature Coefficient		±0.02%/°C max.
Transient Response	25% load step change	250µs
Over Voltage Protection	3.3V	3.7-5.4V
Zener diode clamp (only single)	5V	5.4-7.0V
	12V	13.5-19.6V
	15V	16.8-20.5V
Over Load Protection (% of full load at nominal Vin)		150% typ
Undervoltage Lockout		See Application Notes
Short Circuit Protection		Hiccup, automatic recovery
Efficiency		see „Selection Guide“ table
Isolation Voltage (rated for one minute)		1600VDC
Isolation Resistance		1 GΩ min.
Isolation Capacitance		1000pF max
Operating Frequency		400kHz typ.
Operating Temperature Range		-40°C to +85°C(with derating)
Maximum Case Temperature		+105°C
Storage Temperature Range		-55°C to +125°C

continued on next page

Specifications (typical at nominal input and 25°C unless otherwise noted)

Thermal Impedance ⁽⁶⁾	Natural convection	18.2°C/Watt
	Natural convection with Heat Sink	15.8°C/Watt
Thermal Shock		MIL-STD-810F
Vibration		10-55Hz, 10G, 30 Min. along X, Y and Z
Relative Humidity		5% to 95% RH
Case Material		Nickel plated copper
Base Material		FR4 PCB
Potting Material		Epoxy (UL94-V0)
Conducted Emissions ⁽⁷⁾	EN55022	Class A
Radiated Emissions	EN55022	Class A
ESD	EN61000-4-2	Perf. Criteria A
Radiated Immunity	EN61000-4-3	Perf. Criteria A
Fast Transient	EN61000-4-4	Perf. Criteria A
Surge ⁽⁸⁾	EN61000-4-5	Perf. Criteria A
Conducted Immunity	EN61000-4-6	Perf. Criteria A
Weight		15g
Packing Quantity	Refer to App Notes for tube dimensions	8 pcs per Tube
Dimensions		25.4 x 25.4 x 9.9mm
MTBF ⁽⁹⁾	Bellcore TR-NWT-000332	1330 x 10 ³ hours
	MIL-HDBK 217F	563 x 10 ³ hours

Notes :

- Values at nominal input voltage and no load/full load.
- Typical Value at nominal input voltage and full load.
- Test by minimum V_{in} and constant resistor load.
- Simulated source impedance of 12 μ H. 12 μ H inductor in series with + V_{in} .
- The ON/OFF control function can be positive or negative logic. The pin voltage is referenced to negative input.
Positive logic ON/OFF is marked with suffix-P (eg. RP15-2405SA/P)
Negative logic ON/OFF is marked with suffix-N (eg. RP15-2405SA/N).
If no suffix is specified, the control pin will be omitted.
- Optional Heat-sink P/N is 7G-0047-C. Powerline DC/DC Converters can be ordered with pre-mounted heatsinks including antivibration fixing clips (add suffix -HC). See Application Notes for heatsink details.
- Meets Class A with external input capacitors shown below. Will meet Class B with external common mode filter (see Application Notes)
- Requires external capacitor to meet EN61000-4-5: 220 μ F/100V, low ESR (48mOhm)
- BELLCORE TR-NWT-000332. Case I: 50% Stress, Temperature at 40°C.
MIL-HDBK 217F Notice 2. $T_a = 25^\circ\text{C}$, full load, (Ground, Benign, controlled environment).

External Output Trimming (optional)

With suffix /CTRL, the output can be externally trimmed by using the method shown here.
See Application Notes for details

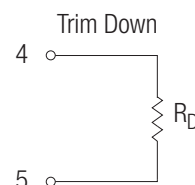
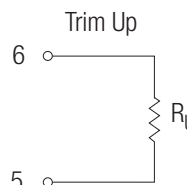

Typical Characteristics

RP15-4805SA

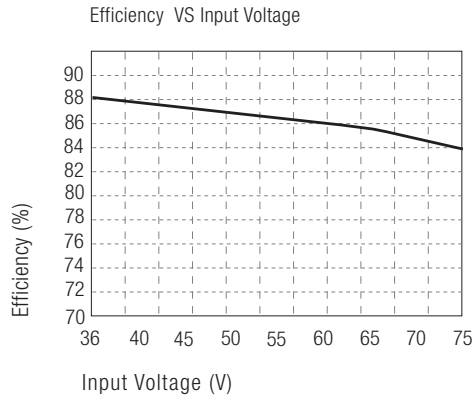

RP15-4805SA

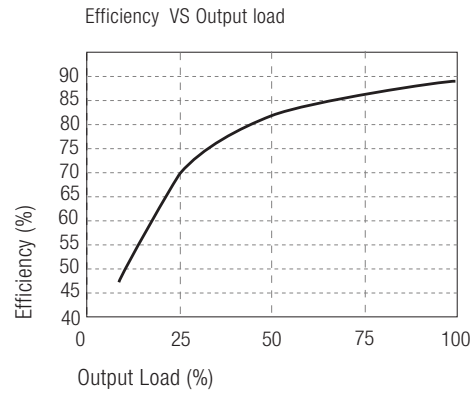

Package Style and Pinning (mm)

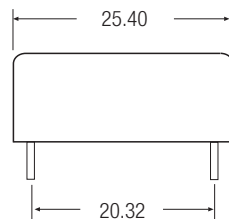
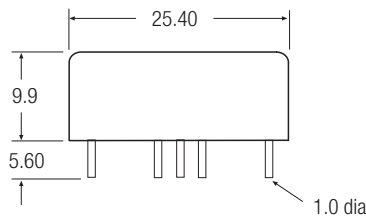

Pin Connections

Pin #	Single	Single/ P or /N	Dual	Dual/ P or /N
1	+Vin	+Vin	+Vin	+Vin
2	-Vin	-Vin	-Vin	-Vin
3	no pin	CTRL	no pin	CTRL
4	+Vout	+Vout	+Vout	+Vout
5	no pin	Trim	Com	Com
6	-Vout	-Vout	-Vout	-Vout

Case Tolerance ± 0.5 mm

Pin Pitch Tolerance ± 0.25 mm

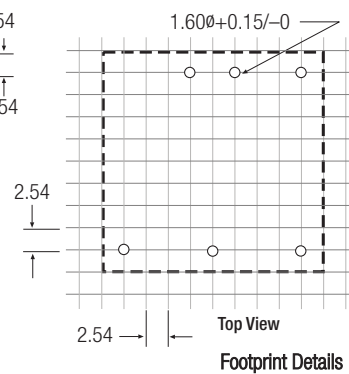
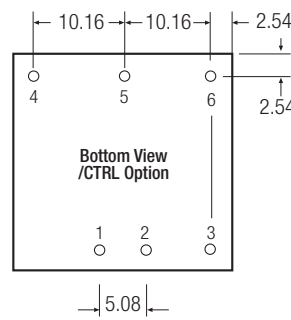
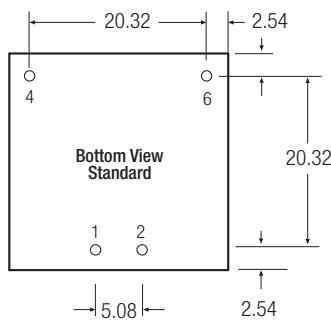

RP15-A

EMC Filtering - For Class B filter suggestion, see Application Notes

Class A Filter

Vin=12V: C1=10 μ F/25V 1812 MLCC, C2 omitted.
 Vin=24V: C1=6.8 μ F/50V 1812 MLCC, C2 omitted.
 Vin=48V: C1, C2 = 2.2 μ F/100V 1812 MLCC

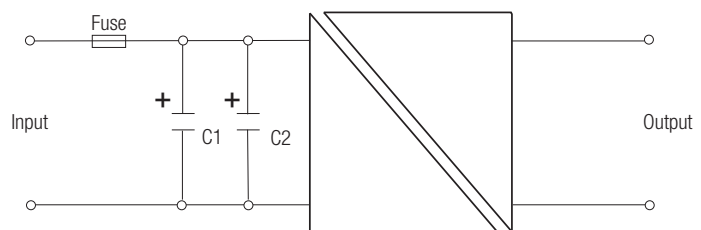

The product information and specifications are subject to change without prior notice. All products are designed for non-safety critical commercial and industrial applications. The Buyer agrees to implement safeguards that anticipate the consequences of any failures that might cause harm, loss of life and/or damage property.

Features

- Ultraminiature 25.4 x25.4x9.9mm Package
- 15 Watts Output Power
- Single or Dual Outputs
- Wide 4:1 Input Voltage Range
- 1.6kVDC Isolation
- Fixed Operating Frequency
- Six-Sided Continuous Shield
- Industry Standard Pinout
- Remote On/Off and Trim pins
- Efficiency to 87 %

Description

The RP15-SAW series are ultraminiature wide input voltage range power DC/DC converters in a case half the size of industry standard 15W converters. Despite their small size, the RP15-SAW converters are fully specified devices with output currents up to 4 Amps, no minimum load, 1600VDC isolation and low ripple/noise figures. The outputs are also fully protected against short circuits, overcurrent and overvoltage. The RP15-SAW series will find many uses in applications where board space and/or board height is at a premium.

Selection Guide 24V and 48V Input Types

Part Number	Input Range VDC	Output Voltage VDC	Output Current mA	Input (1) Current mA	Efficiency (2) %	Capacitive (3) Load max.
RP15-243.3SAW**	9-36	3.3	4000	50/688	86	1000µF
RP15-2405SAW**	9-36	5	3000	70/762	86	1000µF
RP15-2412SAW**	9-36	12	1300	20/783	87	330µF
RP15-2415SAW**	9-36	15	1000	20/753	87	220µF
RP15-483.3SAW**	18-75	3.3	4000	40/336	86	1000µF
RP15-4805SAW**	18-75	5	3000	40/382	86	1000µF
RP15-4812SAW**	18-75	12	1300	15/392	87	330µF
RP15-4815SAW**	18-75	15	1000	15/377	87	220µF
RP15-2405DAW**	9-36	±5	±1500	20/772	85	±500µF
RP15-2412DAW**	9-36	±12	±625	25/753	87	±150µF
RP15-2415DAW**	9-36	±15	±500	25/744	88	±100µF
RP15-4805DAW**	18-75	±5	±1500	15/386	85	±500µF
RP15-4812DAW**	18-75	±12	±625	15/382	86	±150µF
RP15-4815DAW**	18-75	±15	±500	15/377	87	±100µF

** Standard part is without suffixes and Trim and CTRL pins are not fitted.

* add suffix /P for CTRL function with positive logic (1=ON, 0=OFF) including trim pin for single output

* add suffix /N for CTRL function with negative logic (0=ON, 1=OFF) including trim pin for single output

* add suffix -HC for premounted heatsink and clips

Ordering Examples

RP15-2405SAW/P = 24V 4:1 Input, 5V Output, Positive Logic CTRL pin and Trim pin fitted.

RP15-4805DAW-HC = 48V 4:1 Input, ±5V Output, Premounted Heatsink

RP15-483.3DAW/N = 48V 4:1 Input, ±5V Output, Negative Logic CTRL pin (no trim pin with dual output)

Derating graphs are valid only for the shown part numbers. If you need detailed derating-information about a part-number not shown here please contact our technical support service at info@recom-development.at

POWERLINE

DC/DC-Converter

with 3 year Warranty

RECOM

15 Watt Single & Dual Output



**UL-60950-1 Certified
E196683**

RP15-AW

Derating Graph (Ambient Temperature)

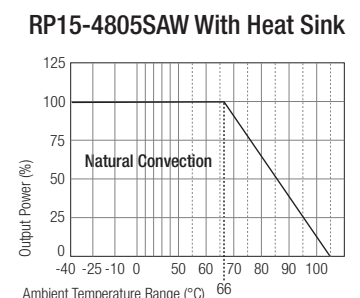
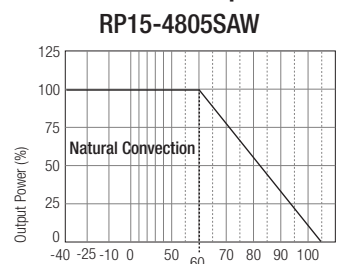

Refer to Application Notes

Specifications (typical at nominal input and 25°C unless otherwise noted)

Input Voltage Range	24V nominal input	9-36VDC
	48V nominal input	18-75VDC
Input Filter		Pi Type
Input Surge Voltage (100 ms max.)	24V Input	50VDC
	48V Input	100VDC
Input Reflected Ripple (nominal Vin and full load) ⁽⁴⁾		30mA _{p-p}
Start Up Time (nominal Vin and constant resistor load)		30ms max.
Optional Remote ON/OFF ⁽⁵⁾ (Negative logic)	DC-DC ON	Short or 0V < Vr < 1.2V
	DC-DC OFF	Open or 3.0V < Vr < 12V
Remote Pin drive current	Nominal Vin	-0.5mA~1.0mA
Remote OFF input current	Nominal Vin	2.5mA
Output Voltage Accuracy (full Load and nominal Vin)		±1%
Optional Output Trim ⁽⁶⁾		±10%
Minimum Load		0%
Line Regulation (low line, high line at full load)	Single	±0.2%
	Dual	±0.5%
Load Regulation (0% to full load)	Single	±0.2%
	Dual	±1%
Cross Regulation (Asymmetrical 25% <> 100% load)	Dual Output	±5%
Ripple and Noise (20MHz bandwidth, with 1µF MLCC on output)	3.3, 5V Outputs	75mV _{p-p}
	Others	100mV _{p-p}
Temperature Coefficient		±0.02%/°C max.
Transient Response (25% load step change)		250µs
Over Voltage Protection	3.3V	3.7-5.4V
Zener diode clamp (only single)	5V	5.4-7.0V
	12V	13.5-19.6V
	15V	16.8-20.5V
Over Load Protection (% of full load at nominal Vin)		150% typ
Undervoltage Lockout		See Application Notes
Short Circuit Protection		Hiccup, automatic recovery
Efficiency		see „Selection Guide“ table
Isolation Voltage (rated for one minute)		1600VDC
Isolation Resistance		1 GΩ min.
Isolation Capacitance		1000pF max. Operating Frequency 400kHz typ
Operating Temperature Range		-40°C to +85°C(with derating)
Maximum Case Temperature		+105°C
Storage Temperature Range		-55°C to +125°C
Thermal Impedance ⁽⁶⁾	Natural convection	18.2°C/Watt
	Natural convection with Heat Sink	15.8°C/Watt
Thermal Shock		MIL-STD-810F

continued on next page

Specifications (typical at nominal input and 25°C unless otherwise noted)

Vibration	10-55Hz, 10G, 30 Min. along X, Y and Z	
Relative Humidity	5% to 95% RH	
Case Material	Nickel plated copper	
Base Material	FR4 PCB	
Potting Material	Epoxy (UL94-V0)	
Conducted Emissions ⁽⁷⁾	EN55022	Class A
Radiated Emissions	EN55022	Class A
ESD	EN61000-4-2	Perf. Criteria A
Radiated Immunity	EN61000-4-3	Perf. Criteria A
Fast Transient	EN61000-4-4	Perf. Criteria A
Surge ⁽⁸⁾	EN61000-4-5	Perf. Criteria A
Conducted Immunity	EN61000-4-6	Perf. Criteria A
Weight	15g	
Packing Quantity	Refer to App Notes for tube dimensions	8 pcs per Tube
Dimensions	25.4 x 25.4 x 9.9mm	
MTBF ⁽⁹⁾	Bellcore TR-NWT-000332 MIL-HDBK 217F	1330 x 10 ³ hours 563 x 10 ³ hours

Notes :

1. Values at nominal input voltage and no load/full load.
2. Typical Value at nominal input voltage and full load.
3. Test by minimum V_{in} and constant resistor load.
4. Simulated source impedance of 12 μ H. 12 μ H inductor in series with + V_{in} .
5. The ON/OFF control function can be positive or negative logic. The pin voltage is referenced to negative input.
Positive logic ON/OFF is marked with suffix-P (eg. RP15-2405SAW/P)
Negative logic ON/OFF is marked with suffix-N (eg. RP15-2405SAW/N).
If no suffix is specified, the control pin will be omitted.
6. Optional Heat-sink P/N is 7G-0047-C. Powerline DC/DC Converters can be ordered with pre-mounted heatsinks including antivibration fixing clips (add suffix -HC). See Application Notes for heatsink details.
7. Meets Class A with external input capacitors shown below. Will meet Class B with external common mode filter (see Application Notes)
8. Requires external capacitor to meet EN61000-4-5: 220 μ F/100V, low ESR (48mOhm)
9. BELLCORE TR-NWT-000332. Case I: 50% Stress, Temperature at 40°C.
MIL-HDBK 217F Notice 2. $T_a = 25^\circ\text{C}$, full load, (Ground Benign, controlled environment).

External Output Trimming (optional)

With /CTRL suffix, output can be externally trimmed by using the method shown here.
See Application Notes for details.

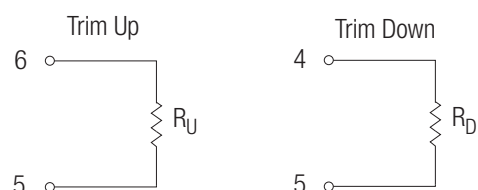

Typical Characteristics

RP15-4805SAW

Efficiency VS Input Voltage

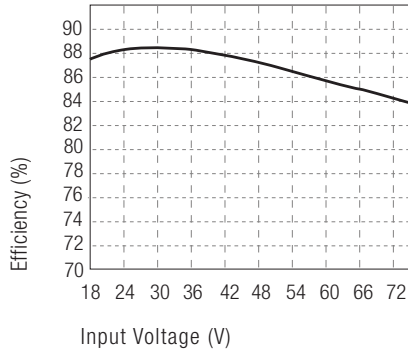

RP15-4805SAW

Efficiency VS Output load

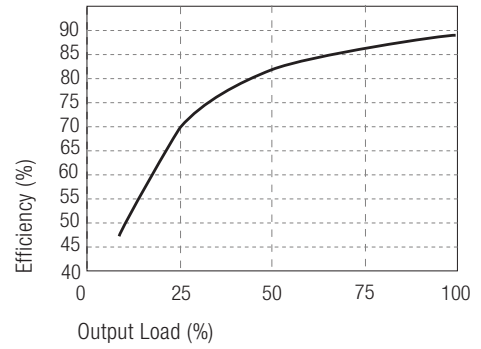

Package Style and Pinning (mm)

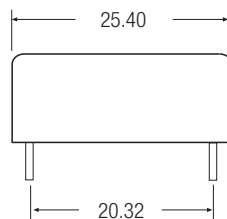
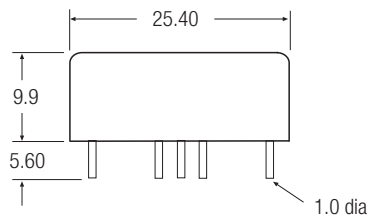

Pin Connections

Pin #	Single	Single/ P or /N	Dual	Dual/ P or /N
1	+Vin	+Vin	+Vin	+Vin
2	-Vin	-Vin	-Vin	-Vin
3	no pin	CTRL	no pin	CTRL
4	+Vout	+Vout	+Vout	+Vout
5	no pin	Trim	Com	Com
6	-Vout	-Vout	-Vout	-Vout

Case Tolerance ± 0.5 mm

Pin Pitch Tolerance ± 0.25 mm

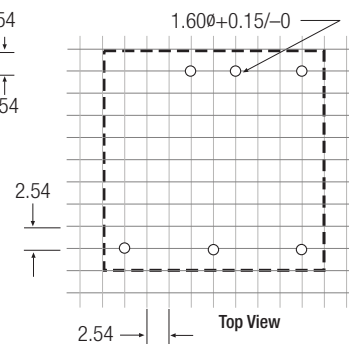
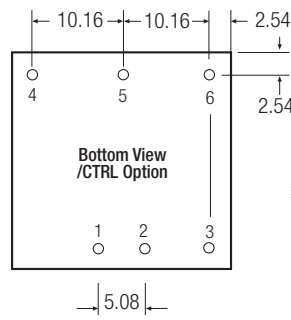
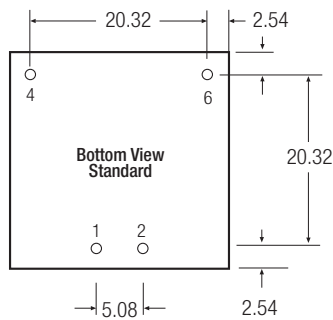

Footprint Details

RP15-AW

EMC Filtering - For Class B filter suggestion, see Application Notes

Class A Filter

Vin=24V: C1=6.8μF/50V 1812 MLCC, C2 omitted.

Vin=48V: C1, C2 = 2.2μF/100V 1812 MLCC

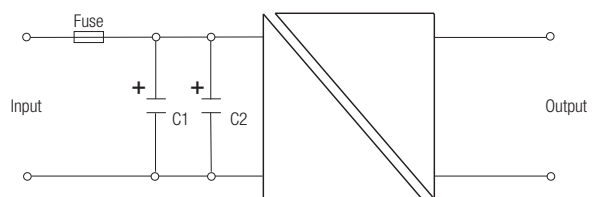

The product information and specifications are subject to change without prior notice. All products are designed for non-safety critical commercial and industrial applications. The Buyer agrees to implement safeguards that anticipate the consequences of any failures that might cause harm, loss of life and/or damage property.

Features

- 2:1 Wide Input Voltage Range
- 15 Watts Output Power
- 1.6kVDC Isolation
- UL Certified
- Fixed Operating Frequency
- Six-Sided Continuous Shield
- Standard 50.8 x 25.4 x 10.2mm Package
- Efficiency to 88 %

Description

The RP15-F series DC/DC converters are certified to UL 60950-1 and to cUL 60950-1. This makes them ideal for all telecom and industrial applications where approved safety standards are required. The industry standard 2" x 1" package meets military standards for thermal shock and vibration tolerance.

Selection Guide 12V, 24V and 48V Input Types

Part Number	Input Range VDC	Output Voltage VDC	Output Current mA	Input ⁽⁴⁾ Current mA	Efficiency ⁽⁵⁾ %	Capacitive ⁽⁶⁾ Load max.
RP15-123.3SF	9-18	3.3	4000	1467	79	10200µF
RP15-1205SF	9-18	5	3000	1603	82	7050µF
RP15-1212SF	9-18	12	1250	1524	86	1035µF
RP15-1215SF	9-18	15	1000	1524	86	705µF
RP15-243.3SF	18-36	3.3	4000	724	80	10200µF
RP15-2405SF	18-36	5	3000	781	84	7050µF
RP15-2412SF	18-36	12	1250	772	85	1035µF
RP15-2415SF	18-36	15	1000	772	85	705µF
RP15-483.3SF	36-75	3.3	4000	357	81	10200µF
RP15-4805SF	36-75	5	3000	396	83	7050µF
RP15-4812SF	36-75	12	1250	377	87	1035µF
RP15-4815SF	36-75	15	1000	381	86	705µF
RP15-1205DF	9-18	±5	±1500	1582	83	±1020µF
RP15-1212DF	9-18	±12	±625	1524	86	±495µF
RP15-1215DF	9-18	±15	±500	1563	84	±165µF
RP15-2405DF	18-36	±5	±1500	781	84	±1020µF
RP15-2412DF	18-36	±12	±625	762	86	±495µF
RP15-2415DF	18-36	±15	±500	762	86	±165µF
RP15-4805DF	36-75	±5	±1500	386	85	±1020µF
RP15-4812DF	36-75	±12	±625	372	88	±495µF
RP15-4815DF	36-75	±15	±500	377	87	±165µF

* add /P for CTRL function with Positive Logic (1=ON, 0=OFF)

* add /N for CTRL function with Negative Logic (0=ON, 1=OFF)

* add suffix -HC for premounted heatsink and clips

Ordering Examples

RP15-2405SF/P = 24V Input, 5V Output, Positive Logic CTRL pin fitted

RP15-4805DF-HC = 48V Input, ±5V Output, No CTRL pin, Heatsink fitted

Derating graphs are valid only for the shown part numbers. If you need detailed derating-information about a part-number not shown here please contact our technical support service at info@recom-development.at

POWERLINE

DC/DC-Converter

with 3 year Warranty

RECOM

15 Watt

2" x 1"

Single &

Dual Output



UL-60950-1 Certified
E196683

RP15-F

Derating Graph (Ambient Temperature)

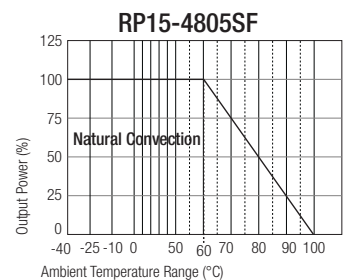

RP15-4805SF With Heat Sink

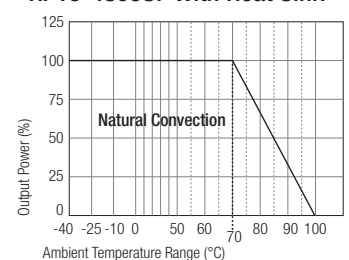

Refer to Application Notes

Typical Characteristics

RP15-4805SF

Efficiency VS Input Voltage

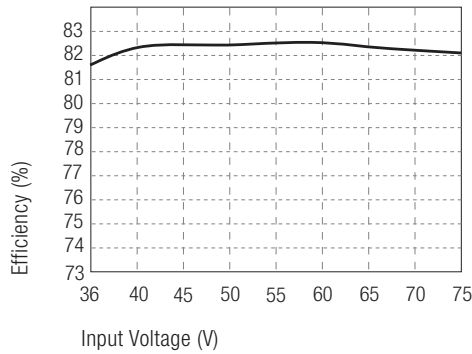

RP15-4805SF

Efficiency VS Output load

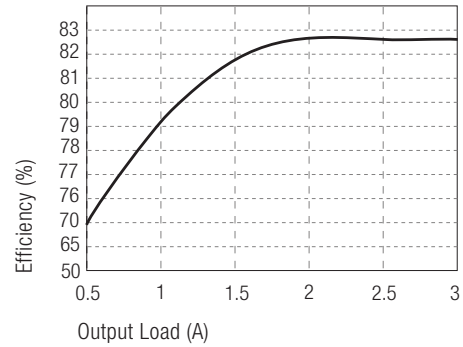

Specifications (typical at nominal input and 25°C unless otherwise noted)

Input Voltage Range	12V nominal input	9-18VDC
	24V nominal input	18-36VDC
	48V nominal input	36-75VDC
Input Filter		Pi Type
Input Surge Voltage (100 ms max.)	12V Input	36VDC
	24V Input	50VDC
	48V Input	100VDC
Input Reflected Ripple (nominal Vin and full load) ⁽³⁾		20mA _{p-p}
Start Up Time (nominal Vin and constant resistor load)		20ms typ.
Remote ON/OFF ⁽⁷⁾	(Positive logic)	DC-DC ON DC-DC OFF
	(Negative logic)	DC-DC ON DC-DC OFF
Remote OFF input current	Nominal input	20mA
Output Power		15W max.
Output Voltage Accuracy (full Load and nominal Vin)		±1%
Minimum Load ⁽¹⁾		10% of full load
Line Regulation (low line, high line at full load)		±1%
Load Regulation (25% to 100% full load)	Single	±1%
	Dual	±2%
Cross Regulation (asymmetrical 25% y-<>100% load)		±5%
Ripple and Noise (20MHz bandwidth, with 1µF MLCC on output)	Single	50mV _{p-p}
	Dual	75mV _{p-p}
Temperature Coefficient		±0.02%/°C max.

continued on next page

Specifications (typical at nominal input and 25°C unless otherwise noted)

Transient Response (25% load step change)		500µs
Over Voltage Protection	3.3V	3.9V
Zener diode clamp (only single)	5V	6.2V
	12V	15V
	15V	18V
Over Load Protection (% of full load at nominal Vin)		150% typ
Undervoltage Lockout		none
Short Circuit Protection		Hiccup, automatic recovery
Efficiency		see „Selection Guide“ table
Isolation Voltage (rated for one minute)		1600VDC
Isolation Resistance		1 GΩ min.
Isolation Capacitance		300pF max.
Operating Frequency	Single	500kHz typ.
	Dual	300kHz typ.
Approved to Safety Standards		UL 1950, EN60950
Operating Temperature Range		-40°C to +85°C(with derating)
Maximum Case Temperature		+100°C
Storage Temperature Range		-55°C to +125°C
Thermal Impedance ⁽⁸⁾	Natural convection	12°C/Watt
	Natural convection with Heat Sink	10°C/Watt
Thermal Shock		MIL-STD-810D
Vibration		10-55Hz, 10G, 30 Min. along X, Y and Z
Relative Humidity		5% to 95% RH
Case Material		Nickel plated copper
Base Material		Non-conductive black plastic
Potting Material		Epoxy (UL94-V0)
Conducted Emissions ⁽⁹⁾	EN55022	Class A
Radiated Emissions	EN55022	Class A
ESD	EN61000-4-2	Perf. Criteria B
Radiated Immunity	EN61000-4-3	Perf. Criteria B
Fast Transient ⁽⁹⁾	EN61000-4-4	Perf. Criteria B
Surge ⁽⁹⁾	EN61000-4-5	Perf. Criteria B
Conducted Immunity	EN61000-4-6	Perf. Criteria B
Weight		27g
Packing Quantity	Refer to App Notes for tube dimensions	9 pcs per Tube
Dimensions		50.8 x 25.4 x 10.2mm
MTBF ⁽²⁾		2041 x 10 ³ hours

Notes :

1. The RP15 series requires a minimum of 10% loading on the output to maintain specified regulation. Operation under no-load condition will not damage these devices, however they may not meet all listed specification.
2. BELLCORE TR-NWT-000332. Case I: 50% Stress, Temperature at 40°C (Ground fixed and controlled environment).
3. Simulated source impedance of 12μH. 12μH inductor in series with +Vin.
4. Maximum value at nominal input voltage and full load of standard type.
5. Typical value at nominal input voltage and full load.
6. Test by minimum Vin and constant resistor load.
7. The ON/OFF control function can be positive or negative logic. The pin voltage is referenced to negative input.
 - Positive logic ON/OFF is marked with suffix-P (eg. RP15-2405SF/P)
 - Negative logic ON/OFF is marked with suffix-N (eg. RP15-2405SF/N).
 - If no suffix is specified, the control pin will be omitted.
8. Heat sink is optional and P/N: 7G-0020-C. Powerline DC/DC Converters can be ordered with pre-mounted heatsinks including antivibration fixing clips (add suffix -HC). See Application Notes for heatsink details.
9. RP15-24xx meets Class A. RP15-48xx requires 1μF MLCC across input to meet Class A. An external capacitor (220μF/Low ESR) is required to meet EN61000-4-4 and -5. See application notes for Class B common mode filter suggestion.

Package Style and Pinning (mm)

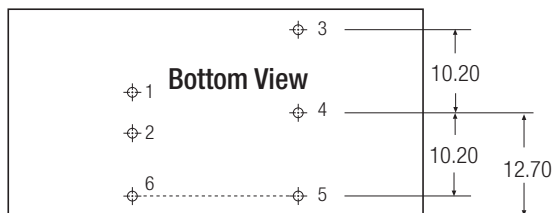
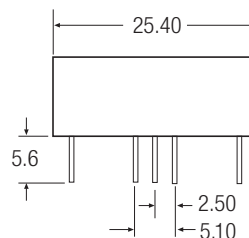
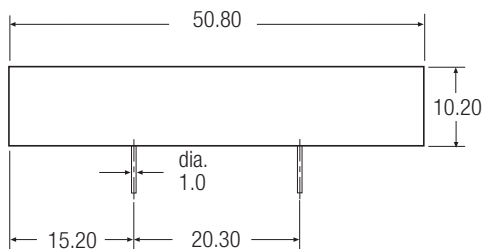

Pin Connections

Pin #	Single	Dual
1	+Vin	+Vin
2	-Vin	-Vin
3	+Vout	+Vout
4	No Pin	Com
5	-Vout	-Vout
6*	CTRL*	CTRL*

* Optional. See Note 7.

Pin Pitch Tolerance ±0.35 mm

Features

Regulated Converters

- 4:1 Wide Input Voltage Range
- 15 Watts Regulated Output Power
- 1.6kVDC Isolation
- Over Current and Over Voltage Protection
- Six-Sided Shield
- No Derating to 65°C
- Standard 2" x 1" Package and Pinning
- Efficiency to 86 %

Description

The RP15-FW series wide range input DC/DC converters are certified to UL 60950-1 and to cUL 60950-1. This makes them ideal for all telecom and industrial applications where approved safety standards are required. The industry standard 2" x 1" package meets military standards for thermal shock and vibration tolerance.

Selection Guide 24V and 48V Wide Input Types

Part Number	Input Range VDC	Output Voltage VDC	Output Current mA	Input ^(4,5) Current mA	Efficiency ⁽⁶⁾ %	Capacitive ⁽⁷⁾ Load max. μ F
RP15-243.3SFW	9-36	3.3	4500	60/773	84	14750 μ F
RP15-2405SFW	9-36	5	3000	60/777	86	7200 μ F
RP15-2412SFW	9-36	12	1250	75/771	85	1250 μ F
RP15-2415SFW	9-36	15	1000	75/762	86	800 μ F
RP15-483.3SFW	18-75	3.3	4500	30/422	84	14750 μ F
RP15-4805SFW	18-75	5	3000	30/381	86	7200 μ F
RP15-4812SFW	18-75	12	1250	40/385	85	1250 μ F
RP15-4815SFW	18-75	15	1000	40/381	86	800 μ F
RP15-2405DFW	9-36	\pm 5	\pm 1500	85/801	82	\pm 3600 μ F
RP15-2412DFW	9-36	\pm 12	\pm 625	100/771	85	\pm 625 μ F
RP15-2415DFW	9-36	\pm 15	\pm 500	100/762	86	\pm 400 μ F
RP15-4805DFW	18-75	\pm 5	\pm 1500	45/400	82	\pm 3600 μ F
RP15-4812DFW	18-75	\pm 12	\pm 625	50/385	85	\pm 625 μ F
RP15-4815DFW	18-75	\pm 15	\pm 500	50/381	86	\pm 400 μ F

* add /P for CTRL function with Positive Logic (1=ON, 0=OFF)

* add /N for CTRL function with Negative Logic (0=ON, 1=OFF)

* add suffix -HC for premounted heatsink and clips

Ordering Examples

RP15-2405SFW/P = 24V 4:1 Input, 5V Output, Positive Logic CTRL pin fitted

RP15-4805DFW-HC = 48V 4:1 Input, \pm 5V Output, No CTRL pin, Heatsink fitted

POWERLINE

DC/DC-Converter

with 3 year Warranty

RECOM

15 Watt 2" x 1" Single & Dual Output



**UL-60950-1 Certified
E196683**

RP15-FW

Derating Graph

(Ambient Temperature)

RP15-4805SFW

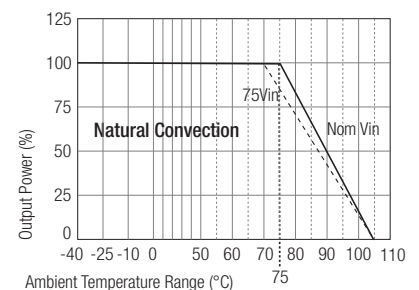

Derating graphs are valid only for the shown part numbers.

If you need detailed derating information about a part number not shown here please contact our technical customer service at info@recom-development.at

Refer to Application Notes

Specifications (typical at nominal input and 25°C unless otherwise noted)

Input Voltage Range	24V nominal input	9-36VDC
	48V nominal input	18-75VDC
Input Filter		Pi Type
Input Surge Voltage (100 ms max.)	24V Input	50VDC
	48V Input	100VDC
Input Reflected Ripple (nominal Vin and full load)		20mA _{p-p}
Start Up Time (nominal Vin and constant resistor load)		20ms typ.
Remote ON/OFF ⁽¹⁾	DC-DC ON	Open or 3.0V < Vr < 12V
	DC-DC OFF	Short or 0V < Vr < 1.2V
Remote OFF input current	Nominal input	2.5mA
Output Power		15W max.
Output Voltage Accuracy (full Load and nominal Vin)		±1%
Minimum Load		0%
Line Regulation (low line, high line at full load)		±0.2%
Load Regulation (0% to 100% full load)	Single	±0.5%
	Dual	±1%
Cross Regulation Dual Output (asymmetrical 25% <>100%load)	Dual	±5%
Ripple and Noise (20MHz bandwidth, with 1µF MLCC on output) (measured with a 104pF ceramic across the output)	3.3, 5.0V	50mV _{p-p}
	12, 15, ±5, ±12, ±15V	75mV _{p-p}
Temperature Coefficient		±0.02%/°C max.
Transient Response (25% load step change)		250µs
Input Voltage Variation, dv/dt	complies with ETS300 132, part 4.4	5V/ms
Over Load Protection (% of full load at nominal Vin)		150% typ
Overvoltage Protection (Single)		Zener Diode Clamp
Undervoltage Protection		See Application Notes
Short Circuit Protection		Continuous, automatic recovery
Efficiency		see „Selection Guide“ table
Isolation Voltage (rated for one minute)	In to Out and I/O to case	1600VDC min.
Isolation Resistance		10 GΩ min.
Isolation Capacitance		1500pF max.
Operating Frequency		400kHz typ.
Operating Temperature Range	5.1, 12, 15, ±12, ±15V	-40°C to +75°C
	3.3, ±5V	-40°C to +65°C
	with derating	-40°C to +105°C
Maximum Case Temperature		+105°C
Storage Temperature Range		-55°C to +125°C
Thermal Impedance ⁽²⁾	Natural convection	12°C/Watt
	with Heatsink	10°C/Watt
Case Material		Nickel plated copper
Base Material		Non-conductive black plastic
Potting Material		Epoxy (UL94-V0)
Weight		27g

continued on next page

Specifications (typical at nominal input and 25°C unless otherwise noted)

Packing Quantity	Refer to App Notes for tube dimensions	9 pcs per TubeC
Conducted Emissions ⁽³⁾	EN55022	Class A
Radiated Emissions ⁽³⁾	EN55022	Class A
ESD	EN61000-4-2	Perf. Criteria B
Radiated Immunity	EN61000-4-3	Perf. Criteria A
Fast Transient ⁽³⁾	EN61000-4-4	Perf. Criteria B
Surge ⁽³⁾	EN61000-4-5	Perf. Criteria B
Conducted Immunity	EN61000-4-6	Perf. Criteria A
Thermal Shock		MIL-STD-810D
Vibration		10-55Hz, 10G, 30 Min. along X, Y and Z
Relative Humidity		5% to 95% RH
MTBF ⁽²⁾	Bellcore-TR-NWT-000332	2350 x 10 ³ hours

Notes :

- The ON/OFF control function can be positive or negative logic. The pin voltage is referenced to negative input.
Positive logic ON/OFF is marked with suffix-P (eg. RP15-2405SFW/P)
Negative logic ON/OFF is marked with suffix-N (eg. RP15-2405SFW/N).
If no suffix is specified, the control pin will be omitted.
- BELLCORE TR-NWT-000332. Case I: 50% Stress, Temperature at 40°C (Ground fixed and controlled environment).
- RP15-24xxW meets Class A. RP15-48xxW requires 1µF MLCC across input to meet Class A.
An external capacitor (220µF/Low ESR) is required to meet EN61000-4-4 and -5
See application notes for Class B common mode filter suggestion.
- Typical value at nominal input voltage and no load.
- Maximum value at nominal input voltage and full load
- Typical value at nominal input voltage and full load.
- Test by minimum Vin and constant resistor load.
- Optional Heatsink Part Number 7G-0020-C. Powerline DC/DC Converters can be ordered with pre-mounted heatsinks including antivibration fixing clips (add suffix -HC). See Application Notes for heatsink details.

Package Style and Pinning (mm)

2" x 1" Package Style

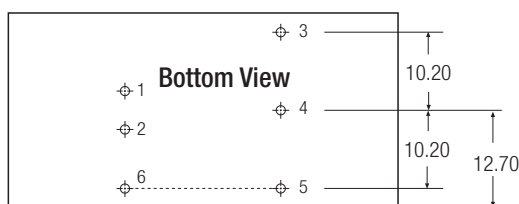
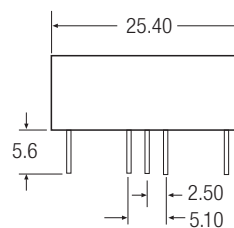
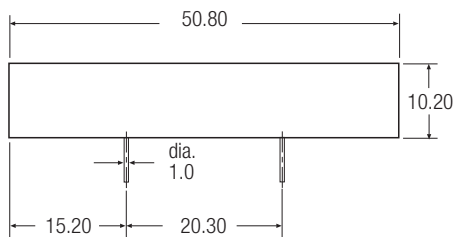

Pin Connections

Pin #	Single	Dual
1	+Vin	+Vin
2	-Vin	-Vin
3	+Vout	+Vout
4	No Pin	Com
5	-Vout	-Vout
6*	CTRL*	CTRL*

* Optional. See Note 1.

Pin Pitch Tolerance ±0.35 mm

The product information and specifications are subject to change without prior notice. All products are designed for non-safety critical commercial and industrial applications. The Buyer agrees to implement safeguards that anticipate the consequences of any failures that might cause harm, loss of life and/or damage property.

Features

- Ultraminiature 25.4 x25.4x9.9mm Package
- 20 Watts Output Power
- Single or Dual Outputs
- Wide 2:1 Input Voltage Range
- 1.6kVDC Isolation
- Fixed Operating Frequency
- Six-Sided Continuous Shield
- Industry Standard Pinout
- Remote On/Off and Trim pins
- Undervoltage Lockout
- Efficiency to 90%

Description

The RP20-SA series are ultraminiature 2:1 input voltage range power DC/DC converters in a case half the size of industry standard 20W converters. Despite their small size, the RP20-SA converters are fully specified devices with output currents up to 4.5 Amps, up to 91% efficiency, no minimum load, 1600VDC isolation, a built-in Class A EMC filter and low ripple/noise figures. The outputs are also fully protected against short circuits, overcurrent and overvoltage. The no load input current is particularly low (only 4mA/6mA).

The RP20-SA series will find many uses in applications where board space and/or board height is at a premium or in battery-powered systems where standby current is important.

Selection Guide 12V, 24V and 48V Input Types

Part Number	Input Range VDC	Output Voltage VDC	Output Current mA	Input Current mA ⁽¹⁾	Efficiency % ⁽²⁾	Capacitive Load max. ⁽³⁾
RP20-123.3SA**	9-18	3.3	4500	10/1510	86	7000µF
RP20-1205SA**	9-18	5	4000	10/1960	89	5000µF
RP20-1212SA**	9-18	12	1670	10/1960	89	850µF
RP20-1215SA**	9-18	15	1330	10/1960	89	700µF
RP20-243.3SA**	18-36	3.3	4500	6/749	87	7000µF
RP20-2405SA**	18-36	5	4000	6/969	90	5000µF
RP20-2412SA**	18-36	12	1670	6/969	90	850µF
RP20-2415SA**	18-36	15	1330	6/958	91	700µF
RP20-483.3SA**	36-75	3.3	4500	4/373	87	7000µF
RP20-4805SA**	36-75	5	4000	4/490	89	5000µF
RP20-4812SA**	36-75	12	1670	4/484	90	850µF
RP20-4815SA**	36-75	15	1330	4/484	90	700µF
RP20-1212DA**	9-18	±12	±833	10/1960	89	±500µF
RP20-1215DA**	9-18	±15	±677	10/1938	90	±350µF
RP20-2412DA**	18-36	±12	±833	6/969	90	±500µF
RP20-2415DA**	18-36	±15	±677	6/969	90	±350µF
RP20-4812DA**	36-75	±12	±833	4/490	89	±500µF
RP20-4815DA**	36-75	±15	±677	4/484	90	±350µF

** Standard part is without suffixes and Trim and CTRL pins are not fitted.

* add suffix /P for CTRL function with positive logic (1=ON, 0=OFF) including trim pin for single output

* add suffix /N for CTRL function with negative logic (0=ON, 1=OFF) including trim pin for single output

* add suffix -HC for premounted heatsink and clips

Ordering Examples

RP20-2405SA/P = 24V Input, 5V Output, Positive Logic CTRL pin and Trim pin fitted

RP20-4812DA-HC = 48V Input, ±12V Output, Heatsink fitted

Derating graphs are valid only for the shown part numbers. If you need detailed derating-information about a part-number not shown here please contact our technical support service at info@recom-development.at

POWERLINE

DC/DC-Converter

with 3 year Warranty

RECOM

20 Watt

1" x 1"

Single &

Dual Output



UL-60950-1 Certification Pending

RP20-A

RP20-A

Derating Graph (Ambient Temperature)

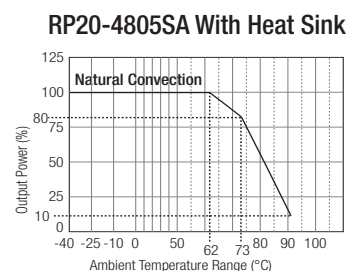
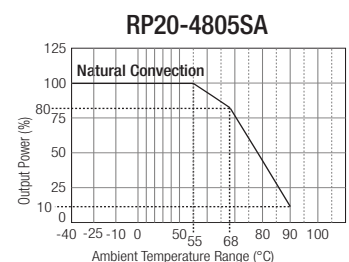

Refer to Application Notes

Specifications (typical at nominal input and 25°C unless otherwise noted)

Input Voltage Range	12V nominal input	9-18VDC
	24V nominal input	18-36VDC
	48V nominal input	36-75VDC
Input Filter	Pi Type	Class A
Input Surge Voltage (1000 ms max.)	12V Input	25VDC
	24V Input	50VDC
	48V Input	100VDC
Input Reflected Ripple (nominal Vin and full load) ⁽⁴⁾		30mAp-p
Start Up Time (nominal Vin and constant resistor load)		30ms max.
Optional Remote ON/OFF ⁽⁶⁾ (Negative logic)	DC-DC ON	Short or 0V < Vr < 1.2V
	DC-DC OFF	Open or 3.0V < Vr < 15V
Remote Pin drive current	Nominal Vin	-0.5mA~1mA
Remote OFF input current	Nominal Vin	2mA
Output Voltage Accuracy (full Load and nominal Vin)		±1%
Optional Output Trim ⁽⁶⁾		±10%
Minimum Load		0%
Line Regulation (low line, high line at full load)	Single	±0.2%
	Dual	±0.5%
Load Regulation (0% to full load)	Single	±0.2%
	Dual	±1%
Cross Regulation (Asymmetrical 25% <>100% load)	Dual Output	±5%
Ripple and Noise (20MHz bandwidth, with 1µF MLCC on output)	3.3, 5V Outputs	75mVp-p
	Others	100mVp-p
Temperature Coefficient		±0.02%/°C max.
Transient Response	25% load step change	250µs
Over Voltage Protection	3.3V	3.7-5.4V
Zener diode clamp (only single)	5V	5.4-7.0V
	12V	13.5-19.6V
	15V	16.8-20.5V
Over Load Protection (% of full load at nominal Vin)		150% typ
Undervoltage Lockout		See Application Notes
Short Circuit Protection		Hiccup, automatic recovery
Efficiency		see „Selection Guide“ table
Isolation Voltage (rated for one minute)		1600VDC
Isolation Resistance		1 GΩ min.
Isolation Capacitance		1000pF max.
Operating Frequency		330kHz typ.
Operating Temperature Range		-40°C to +90°C(with derating)
Maximum Case Temperature		+105°C
Storage Temperature Range		-55°C to +125°C

continued on next page

Specifications (typical at nominal input and 25°C unless otherwise noted)

Thermal Impedance ⁽⁶⁾	Natural convection	18.2°C/Watt
	Natural convection with Heat Sink	15.8°C/Watt
Thermal Shock		MIL-STD-810F
Vibration		10-55Hz, 10G, 30 Min. along X, Y and Z
Relative Humidity		5% to 95% RH
Case Material		Nickel plated copper
Base Material		FR4 PCB
Potting Material		Epoxy (UL94-V0)
Conducted Emissions ⁽⁷⁾	EN55022	Class A
Radiated Emissions	EN55022	Class A
ESD	EN61000-4-2	Perf. Criteria A
Radiated Immunity	EN61000-4-3	Perf. Criteria A
Fast Transient	EN61000-4-4	Perf. Criteria A
Surge ⁽⁸⁾	EN61000-4-5	Perf. Criteria A
Conducted Immunity	EN61000-4-6	Perf. Criteria A
Weight		15g
Packing Quantity	Refer to App Notes for tube dimensions	8 pcs per Tube
Dimensions		25.4 x 25.4 x 9.9mm
MTBF ⁽⁹⁾	Bellcore TR-NWT-000332	1766 x 10 ³ hours
	MIL-HDBK 217F	553 x 10 ³ hours

Notes :

1. Values at nominal input voltage and no load/full load.
2. Typical Value at nominal input voltage and full load.
3. Test by minimum Vin and constant resistor load.
4. Simulated source impedance of 12µH. 12µH inductor in series with +Vin.
5. The ON/OFF control function can be positive or negative logic. The pin voltage is referenced to negative input.
Positive logic ON/OFF is marked with suffix-P (eg. RP20-2405SA/P)
Negative logic ON/OFF is marked with suffix-N (eg. RP20-2405SA/N).
If no suffix is specified, the control pin will be omitted.
6. Optional Heat-sink P/N is 7G-0047-C. Powerline DC/DC Converters can be ordered with pre-mounted heatsinks including antivibration fixing clips (add suffix -HC). See Application Notes for heatsink details.
7. Meets Class A with external input capacitors shown below. Will meet Class B with external common mode filter (see Application Notes)
8. Requires external capacitor to meet EN61000-4-5: 220µF/100V, low ESR (48mOhm)
9. BELLCORE TR-NWT-000332. Case I: 50% Stress, Temperature at 40°C.
MIL-HDBK 217F Notice 2. Ta = 25°C, full load, (Ground, Benign, controlled environment).

External Output Trimming (optional)

With suffix /CTRL, the output can be externally trimmed by using the method shown here.
See Application Notes for details

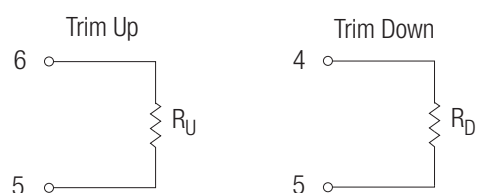

Typical Characteristics

RP20-4805SA (Full Load)

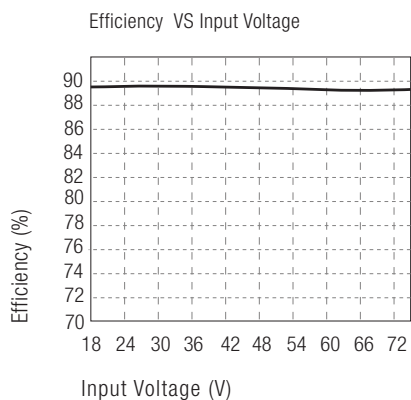

RP20-4805SA (Vin=48V)

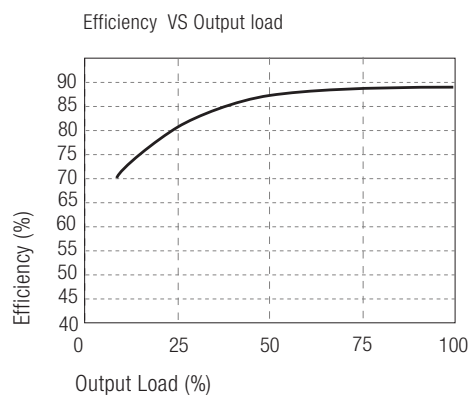

Package Style and Pinning (mm)

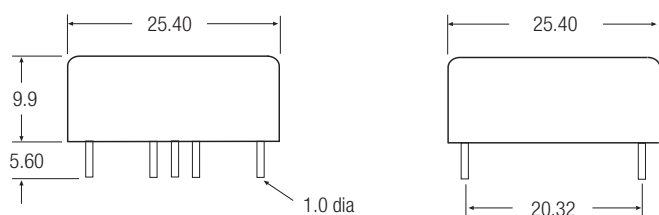

Pin Connections

Pin #	Single	Single/P or /N	Dual	Dual/P or /N
1	+Vin	+Vin	+Vin	+Vin
2	-Vin	-Vin	-Vin	-Vin
3	no pin	CTRL	no pin	CTRL
4	+Vout	+Vout	+Vout	+Vout
5	no pin	Trim	Com	Com
6	-Vout	-Vout	-Vout	-Vout

Case Tolerance ± 0.5 mm
Pin Pitch Tolerance ± 0.25 mm

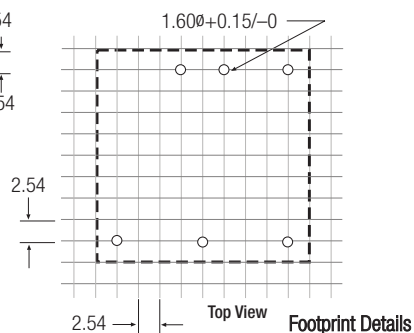
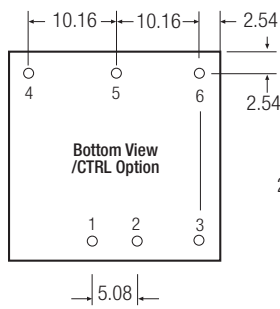
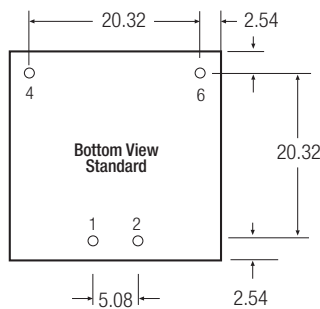

EMC Filtering

Class B Filter

Vin=24V: C1=4.7 μ F/25V 1812 MLCC, C2 & C3 omitted, C4 & C5 =470pF/2kV

Vin=24V: C1=4.7 μ F/50V 1812 MLCC, C2 & C3 omitted, C4 & C5 =470pF/2kV

Vin=48V: C1, C2 & C3 = 2.2 μ F/100V 1812 MLCC, C4 & C5 =1nF/2kV

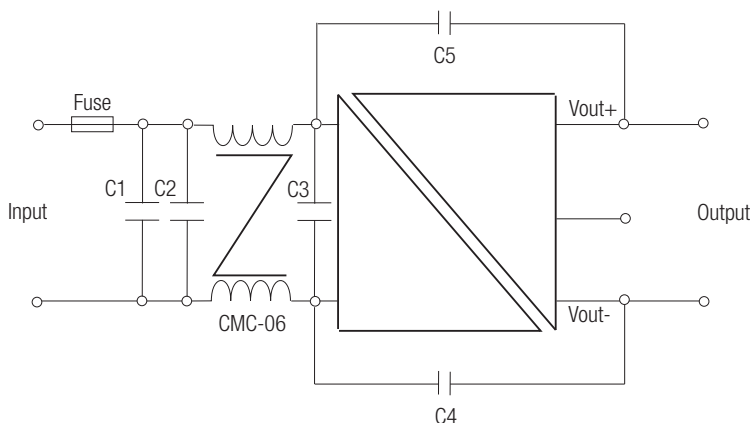

The product information and specifications are subject to change without prior notice. All products are designed for non-safety critical commercial and industrial applications. The Buyer agrees to implement safeguards that anticipate the consequences of any failures that might cause harm, loss of life and/or damage property.

Features

- Ultraminiature 25.4 x25.4x9.9mm Package
- 20 Watts Output Power
- Single or Dual Outputs
- Wide 4:1 Input Voltage Range
- 1.6kVDC Isolation
- Fixed Operating Frequency
- Built-in Class A EMC Filter
- Six-Sided Continuous Shield
- Industry Standard Pinout
- Remote On/Off and Trim pins
- Efficiency to 90%

Description

The RP20-SAW series are ultraminiature wide input voltage range power DC/DC converters in a case half the size of industry standard 20W converters. Despite their small size, the RP20-SAW converters are fully specified devices with output currents up to 4.5 Amps, up to 90% efficiency, no minimum load, 1600VDC isolation, a built-in Class A EMC filter and low ripple/noise figures. The outputs are also fully protected against short circuits, overcurrent and overvoltage. The no load input current is particularly low (only 4mA/6mA).

The RP20-SAW series will find many uses in applications where board space and/or board height is at a premium or in battery-powered systems where standby current is important.

Selection Guide 24V and 48V Input Types

Part Number	Input Range VDC	Output Voltage VDC	Output Current mA	Input ⁽¹⁾ Current mA	Efficiency ⁽²⁾ %	Capacitive ⁽³⁾ Load max.
RP20-243.3SAW**	9-36	3.3	4500	6/754	86	7000µF
RP20-2405SAW**	9-36	5	4000	6/980	89	5000µF
RP20-2412SAW**	9-36	12	1670	6/980	89	850µF
RP20-2415SAW**	9-36	15	1330	6/980	89	700µF
RP20-483.3SAW**	18-75	3.3	4500	4/737	87	7000µF
RP20-4805SAW**	18-75	5	4000	4/490	89	5000µF
RP20-4812SAW**	18-75	12	1670	4/490	89	850µF
RP20-4815SAW**	18-75	15	1330	4/484	90	700µF
RP20-2412DAW**	9-36	±12	±833	6/980	89	±500µF
RP20-2415DAW**	9-36	±15	±667	6/969	90	±350µF
RP20-4812DAW**	18-75	±12	±833	4/490	89	±500µF
RP20-4815DAW**	18-75	±15	±667	4/484	90	±350µF

** Standard part is without suffixes and Trim and CTRL pins are not fitted.

* add suffix /P for CTRL function with positive logic (1=ON, 0=OFF) including trim pin for single output

* add suffix /N for CTRL function with negative logic (0=ON, 1=OFF) including trim pin for single output

* add suffix -HC for premounted heatsink and clips

Ordering Examples

RP20-2405SAW/P = 24V 4:1 Input, 5V Output, Positive Logic CTRL pin and Trim pin fitted.

RP20-483.3SAW-HC = 48V 4:1 Input, 3.3V Output, Premounted Heatsink, No Trim or CTRL pins.

RP20-4812DAW/N = 48V 4:1 Input, ±12V Output, Negative Logic CTRL pin

(no trim pin available with dual output)

Derating graphs are valid only for the shown part numbers. If you need detailed derating information about a part-number not shown here please contact our technical support service at info@recom-development.at

POWERLINE

DC/DC-Converter

with 3 year Warranty

RECOM

20 Watt Single & Dual Output



UL-60950-1 Certification Pending

RP20-AW

RP20-AW

Derating Graph (Ambient Temperature)

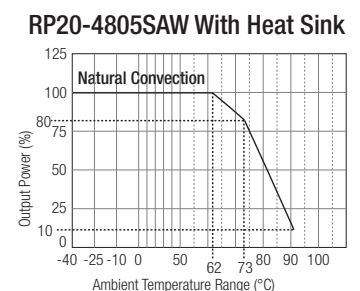
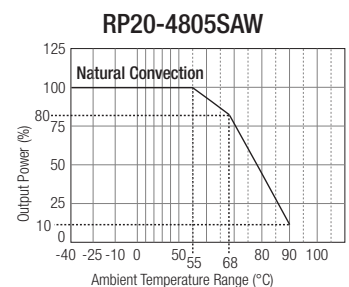

Refer to Application Notes

Specifications (typical at nominal input and 25°C unless otherwise noted)

Input Voltage Range	24V nominal input	9-36VDC
	48V nominal input	18-75VDC
Input Filter	Pi Type	EN55022 Class A
Input Surge Voltage (1000 ms max.)	24V Input	50VDC
	48V Input	100VDC
Input Reflected Ripple (nominal Vin and full load) ⁽⁴⁾		30mA _{p-p}
Start Up Time (nominal Vin and constant resistor load)		30ms max.
Optional Remote ON/OFF ⁽⁵⁾ (Negative logic)	DC-DC ON	Short or 0V < Vr < 1.2V
	DC-DC OFF	Open or 3.0V < Vr < 15V
Remote Pin drive current	Nominal Vin	-0.5mA~1mA
Remote OFF input current	Nominal Vin	2mA
Output Voltage Accuracy (full Load and nominal Vin)		±1%
Optional Output Trim ⁽⁶⁾		±10%
Minimum Load		0%
Line Regulation (low line, high line at full load)	Single	±0.2%
	Dual	±0.5%
Load Regulation (0% to full load)	Single	±0.2%
	Dual	±1%
Cross Regulation (Asymmetrical 25% <> 100% load)	Dual Output	±5%
Ripple and Noise (20MHz bandwidth, with 1µF MLCC on output)	3.3, 5V Outputs	75mV _{p-p}
	Others	100mV _{p-p}
Temperature Coefficient		±0.02%/°C max.
Transient Response (25% load step change)		250µs
Over Voltage Protection	3.3V	3.7-5.4V
Zener diode clamp (only single)	5V	5.4-7.0V
	12V	13.5-19.6V
	15V	16.8-20.5V
Over Load Protection (% of full load at nominal Vin)		150% typ
Undervoltage Lockout		See Application Notes
Short Circuit Protection		Hiccup, automatic recovery
Efficiency		see „Selection Guide“ table
Isolation Voltage (rated for one minute)	Input - Output	1600VDC
Isolation Resistance		1 GΩ min.
Isolation Capacitance		1500pF max.
Operating Frequency		330kHz typ
Operating Temperature Range		-40°C to +90°C (with derating)
Maximum Case Temperature		+105°C
Storage Temperature Range		-55°C to +125°C
Thermal Impedance ⁽⁶⁾	Natural convection	18.2°C/Watt
	Natural convection with Heat Sink	15.8°C/Watt

continued on next page

Specifications (typical at nominal input and 25°C unless otherwise noted)

Thermal Shock		MIL-STD-810F	
Vibration		10-55Hz, 10G, 30 Min. along X, Y and Z	
Relative Humidity		5% to 95% RH	
Case Material		Nickel plated copper	
Base Material		FR4 PCB	
Potting Material		Epoxy (UL94-V0)	
Conducted Emissions ⁽⁷⁾	EN55022	Class A	
Radiated Emissions	EN55022	Class B	
ESD	±8kV Air, ±6kV Contact	EN61000-4-2	Perf. Criteria A
Radiated Immunity	10V/m	EN61000-4-3	Perf. Criteria A
Fast Transient	±2kV	EN61000-4-4	Perf. Criteria A
Surge ⁽⁸⁾	±2kV	EN61000-4-5	Perf. Criteria A
Conducted Immunity	10Vrms	EN61000-4-6	Perf. Criteria A
Weight		15g	
Packing Quantity	Refer to App Notes for tube dimensions	8 pcs per Tube	
Dimensions		25.4 x 25.4 x 9.9mm	
MTBF ⁽⁹⁾	Bellcore TR-NWT-000332	1766 x 10 ³ hours	
	MIL-HDBK 217F	553 x 10 ³ hours	

Notes :

1. Values at nominal input voltage and no load/full load.
2. Typical Value at nominal input voltage and full load.
3. Test by minimum Vin and constant resistor load.
4. Simulated source impedance of 12μH. 12μH inductor in series with +Vin.
5. The ON/OFF control function can be positive or negative logic. The pin voltage is referenced to negative input.
Positive logic ON/OFF is marked with suffix-P (eg. RP20-2405SAW/P)
Negative logic ON/OFF is marked with suffix-N (eg. RP20-2405SAW/N).
If no suffix is specified, the control pin will be omitted.
6. Optional Heat-sink P/N is 7G-0047-C. Powerline DC/DC Converters can be ordered with pre-mounted heatsinks including antivibration fixing clips (add suffix -HC). See Application Notes for heatsink details.
7. Will meet Class B with external common mode filter (see Application Notes). Meets Class A with no external components.
8. Requires external capacitor to meet EN61000-4-5: 220μF/100V, low ESR (48mOhm)
9. BELLCORE TR-NWT-000332. Case I: 50% Stress, Temperature at 40°C.
MIL-HDBK 217F Notice 2. Ta = 25°C, full load, (Ground Benign, controlled environment).

External Output Trimming (optional)

With /CTRL suffix, output can be externally trimmed by using the method shown here.
See Application Notes for details.

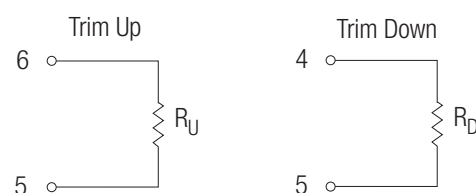

Typical Characteristics

RP20-4805SAW (Full Load)

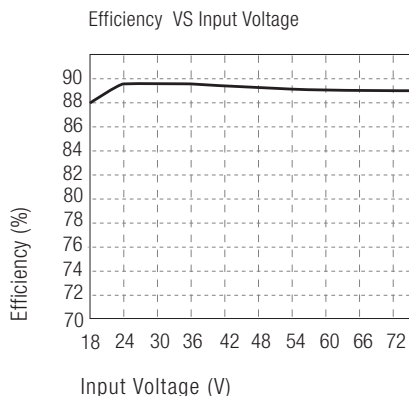

RP20-4805SAW (Vin=48V)

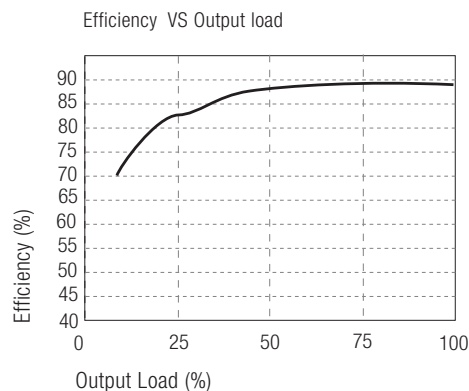

Package Style and Pinning (mm)

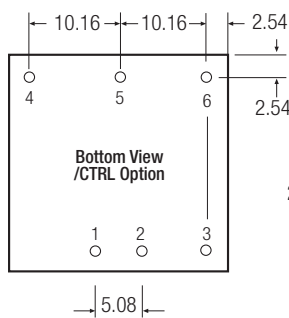
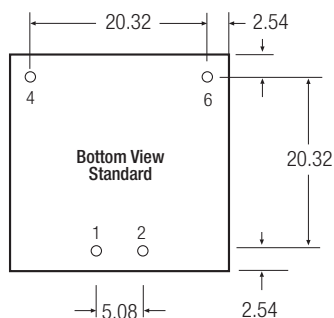
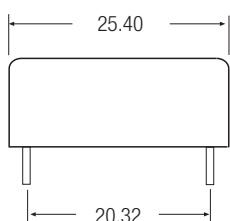
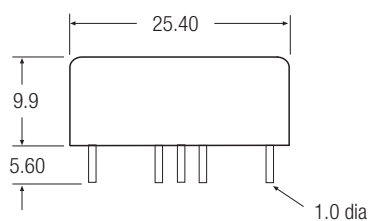

Pin Connections

Pin #	Single	Single/ P or /N	Dual	Dual/ P or /N
1	+Vin	+Vin	+Vin	+Vin
2	-Vin	-Vin	-Vin	-Vin
3	no pin	CTRL	no pin	CTRL
4	+Vout	+Vout	+Vout	+Vout
5	no pin	Trim	Com	Com
6	-Vout	-Vout	-Vout	-Vout

Case Tolerance ± 0.5 mm
Pin Pitch Tolerance ± 0.25 mm

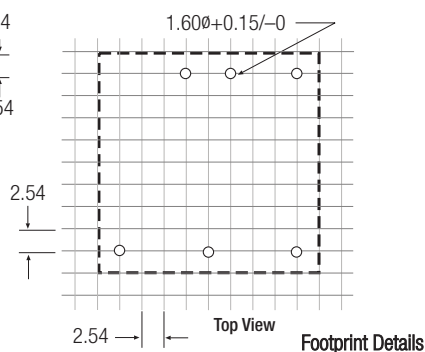

EMC Filtering

Class B Filter

Vin=24V: C1=4.7 μ F/50V 1812 MLCC, C2 & C3 omitted, C4 & C5 =470pF/2kV
Vin=48V: C1, C2 & C3 = 2.2 μ F/100V 1812 MLCC, C4 & C5 =1nF/2kV

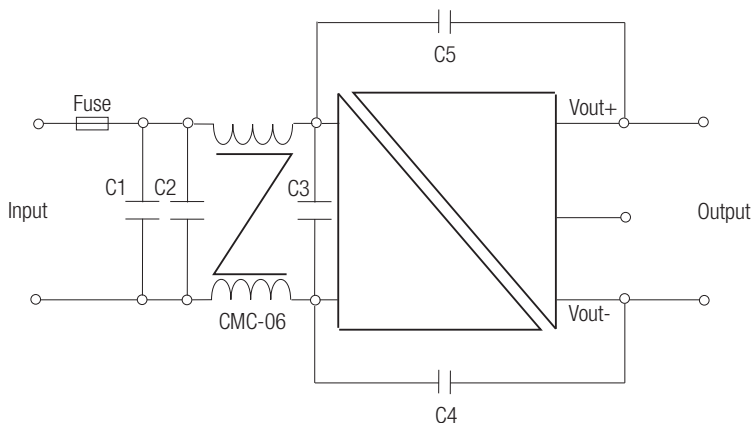

The product information and specifications are subject to change without prior notice. All products are designed for non-safety critical commercial and industrial applications. The Buyer agrees to implement safeguards that anticipate the consequences of any failures that might cause harm, loss of life and/or damage property.

Features

- 2:1 Wide Input Voltage Range
- 20 Watts Output Power
- 1.6kVDC Isolation
- UL Certified
- Fixed Operating Frequency
- Six-Sided Continuous Shield
- Standard 50.8 x25.4x10.2mm Package
- Efficiency to 89%

Description

The RP20-F series DC/DC converters are certified to UL 60950-1 and to cUL 60950-1. This makes them ideal for all telecom and industrial applications where approved safety standards are required. The industry standard 2" x 1" package meets military standards for thermal shock and vibration tolerance.

Selection Guide 12V, 24V and 48V Input Types

Part Number	Input Range VDC	Output Voltage VDC	Output Current mA	Input ⁽⁴⁾ Current mA	Efficiency ⁽⁵⁾ %	Capacitive ⁽⁶⁾ Load max.
RP20-123.3SF	9-18	3.3	5000	1719	84	13000µF
RP20-1205SF	9-18	5	4000	2008	87	6800µF
RP20-1212SF	9-18	12	1670	2062	85	2200µF
RP20-1215SF	9-18	15	1330	2052	85	755µF
RP20-243.3SF	18-36	3.3	5000	838	86	13000µF
RP20-2405SF	18-36	5	4000	980	89	6800µF
RP20-2412SF	18-36	12	1670	1006	87	2200µF
RP20-2415SF	18-36	15	1330	1002	87	755µF
RP20-483.3SF	36-75	3.3	5000	414	87	13000µF
RP20-4805SF	36-75	5	4000	490	89	6800µF
RP20-4812SF	36-75	12	1670	497	88	2200µF
RP20-4815SF	36-75	15	1330	500	87	755µF
RP20-1212DF	9-18	±12	±833	2032	86	±680µF
RP20-1215DF	9-18	±15	±667	2034	86	±450µF
RP20-2412DF	18-36	±12	±833	1004	87	±680µF
RP20-2415DF	18-36	±15	±667	1005	87	±450µF
RP20-4812DF	36-75	±12	±833	496	88	±680µF
RP20-4815DF	36-75	±15	±667	502	87	±450µF

* no suffix for CTRL function with Positive Logic (1=ON, 0=OFF), this is standard

* add /N for CTRL function with Negative Logic (0=ON, 1=OFF)

* add suffix -HC for premounted heatsink and clips

Ordering Examples

RP20-2405SF = 24V Input, 5V Output, Positive Logic CTRL pin fitted

RP20-4812DF/N-HC = 48V Input, ±12V Output, Negative Logic CTRL pin fitted, Heatsink fitted

Derating graphs are valid only for the shown part numbers. If you need detailed derating-information about a part-number not shown here please contact our technical support service at info@recom-development.at

POWERLINE

DC/DC-Converter

with 3 year Warranty

RECOM

20 Watt 2" x 1" Single & Dual Output



**UL-60950-1 Certified
E196683**

RP20-F

Derating Graph (Ambient Temperature)

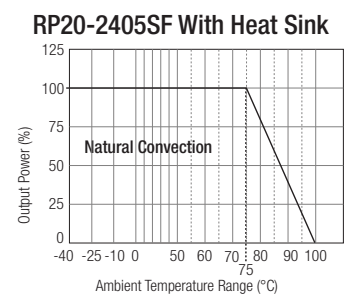
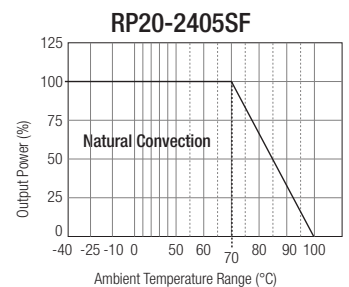

Refer to Application Notes

Typical Characteristics

RP20-2405SF

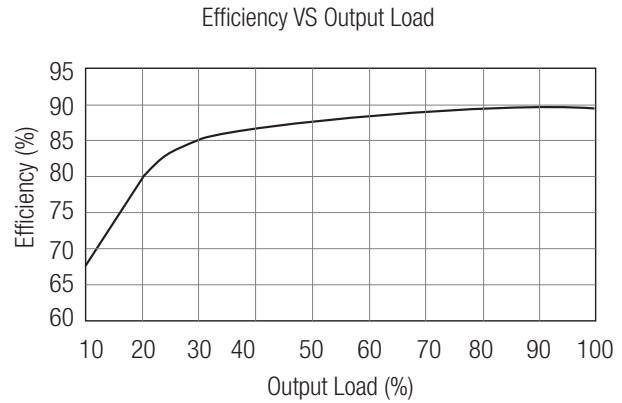
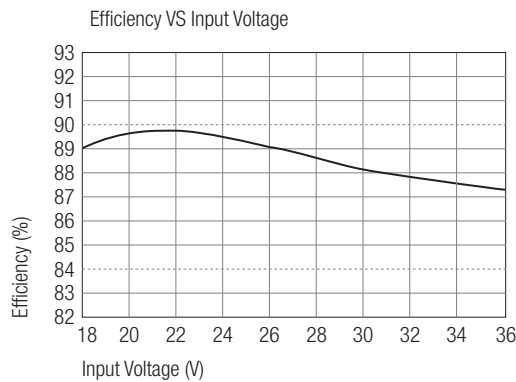

Specifications (typical at nominal input and 25°C unless otherwise noted)

Input Voltage Range	12V nominal input	9-18VDC
	24V nominal input	18-36VDC
	48V nominal input	36-75VDC
Input Filter ⁽⁹⁾		L-C Type
Input Voltage Variation dv/dt	(Complies with ETS300 132 part 4.4)	5V/ms max
Input Surge Voltage (100 ms max.)	12V Input	36VDC
	24V Input	50VDC
	48V Input	100VDC
Input Reflected Ripple (nominal Vin and full load) ⁽³⁾		20mA-p-p
Start Up Time (nominal Vin and constant resistor load)		10ms typ.
Remote ON/OFF ⁽⁷⁾	DC-DC ON	Open or 3.0V < Vr < 12V
	DC-DC OFF	Short or 0V < Vr < 1.2V
Remote OFF input current	Nominal input	2.5mA
Output Power		20W max.
Output Voltage Accuracy (full Load and nominal Vin)		±1%
Voltage Adjustability		±10%
Minimum Load ⁽¹⁾	Single	0%
	Dual	10% of full load
Line Regulation (low line, high line at full load)		±0.2%
Load Regulation (25% to 100% full load)		±0.5%
Cross Regulation (asymmetrical 25% <> 100% load)	Dual	±5%
Ripple and Noise (20MHz bandwidth, with 1µF MLCC on output) (Measured with a 1004pF/50V MLCC)	Single 1.5, 1.8, 2.5, 3.3V	60mVp-p
	Single 5, 12, 15V	75mVp-p
	Dual 5, 12, 15V	100mVp-p

continued on next page

Specifications (typical at nominal input and 25°C unless otherwise noted)

Temperature Coefficient		±0.02%/°C max.
Transient Response (25% load step change)		500µs
Over Voltage Protection	1.5, 1.8, 2.5, 3.3V	3.9V
Zener diode clamp (only single)	5V	6.2V
	12V	15V
	15V	18V
Over Load Protection (% of full load at nominal Vin)		150% typ
Undervoltage Lockout		none
Short Circuit Protection		Hiccup, automatic recovery
Efficiency		see „Selection Guide“ table
Isolation Voltage (rated for one minute)	Input to Output	1600VDC
	Input (Output) to case	1600VDC
Isolation Resistance		1 GΩ min.
Isolation Capacitance		1000pF max.
Operating Frequency		500kHz typ.
Operating Temperature Range		-40°C to +85°C(with derating)
Maximum Case Temperature		+100°C
Storage Temperature Range		-55°C to +125°C
Thermal Impedance ⁽⁹⁾	Natural convection	12°C/Watt
	Natural convection with Heat Sink	10°C/Watt
Thermal Shock		MIL-STD-810D
Vibration		10-55Hz, 10G, 30 Min. along X, Y and Z
Relative Humidity		5% to 95% RH
Case Material		Nickel plated copper
Base Material		Non-conductive black plastic
Potting Material		Epoxy (UL94-V0)
Conducted Emissions ^(9, 10)	EN55022	Class A
Radiated Emissions	EN55022	Class A
ESD	EN61000-4-2	Perf. Criteria B
Radiated Immunity	EN61000-4-3	Perf. Criteria B
Fast Transient	EN61000-4-4	Perf. Criteria B
Surge	EN61000-4-5	Perf. Criteria B
Conducted Immunity	EN61000-4-6	Perf. Criteria B
Weight		27g
Packing Quantity	Refer to App Notes for tube dimensions	9 pcs per Tube
Dimensions		50.8 x 25.4 x 10.2mm
MTBF ⁽²⁾		1791 x 10 ³ hours

Notes :

1. The RP20-S_DF series requires a minimum of 10% loading on the output to maintain specified regulation. Operation under no-load condition will not damage these devices, however they may not meet all listed specification.
2. BELLCORE TR-NWT-000332. Case I: 50% Stress, Temperature at 40°C (Ground fixed and controlled environment).
3. Simulated source impedance of 12μH. 12μH inductor in series with +Vin.
4. Maximum value at nominal input voltage and full load of standard type.
5. Typical value at nominal input voltage and full load.
6. Test by minimum Vin and constant resistor load.
7. The ON/OFF control function can be positive or negative logic. The pin voltage is referenced to negative input.
 - Positive logic ON/OFF is standard, no suffix (Ex. RP20-2405SF)
 - Negative logic ON/OFF is marked with suffix-N (Ex. RP20-2405SF/N).
8. Heat sink is optional and P/N: 7G-0020-C. Powerline DC/DC Converters can be ordered with pre-mounted heatsinks including antivibration fixing clips (add suffix -HC). See Application Notes for heatsink details.
9. An external filter capacitor is required for normal operation. The capacitor should be capable of handling 1A ripple current for 48V/24V models. RECOM suggest: Nippon chemi-con KY series, 220μF/100V, ESR 90m Ω.
10. See application notes for Class B common mode filter suggestion.

Package Style and Pinning (mm)

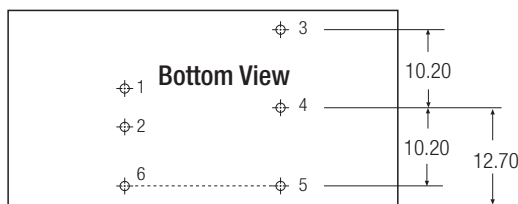
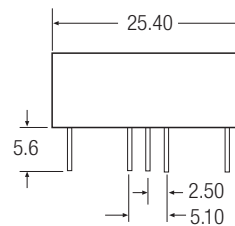
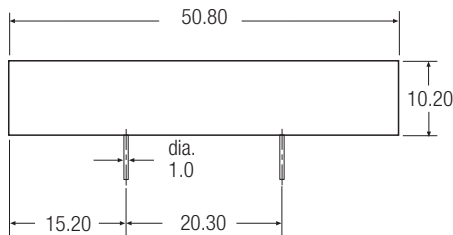

Pin Connections

Pin #	Single	Dual
1	+Vin	+Vin
2	-Vin	-Vin
3	+Vout	+Vout
4	Trim	Com
5	-Vout	-Vout
6	CTRL	CTRL

Pin Pitch Tolerance ±0.35 mm

External Output Trimming

Output can be externally trimmed by using the method shown below. See Application Notes for details.

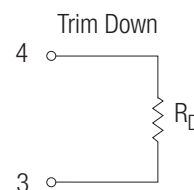
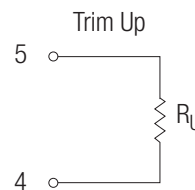

The product information and specifications are subject to change without prior notice. All products are designed for non-safety critical commercial and industrial applications. The Buyer agrees to implement safeguards that anticipate the consequences of any failures that might cause harm, loss of life and/or damage property.

Features

Regulated Converters

- 4:1 Wide Input Voltage Range
- 20 Watts Regulated Output Power
- 1.6kVDC Isolation
- Over Current and Over Voltage Protection
- Six-Sided Shield
- No Derating to 63°C
- Standard 2" x 1" Package and Pinning
- Efficiency to 86 %

Description

The RP20-FW series wide rangew input DC/DC converters are certified to UL 60950-1 and to cUL 60950-1. This makes them ideal for all telecom and industrial applications where approved safety standards are required. The industry standard 2" x 1" package meets military standards for thermal shock and vibration tolerance.

Selection Guide 24V and 48V Wide Input Types

Part Number	Input Range VDC	Output Voltage VDC	Output Current mA	Input Current mA ^(4,5)	Efficiency ⁽⁶⁾ %	Capacitive ⁽⁷⁾ Load max.
RP20-243.3SFW	9-36	3.3	5500	60/922	84	18000µF
RP20-2405SFW	9-36	5	4000	60/1016	86	9600µF
RP20-2412SFW	9-36	12	1670	75/1031	85	1650µF
RP20-2415SFW	9-36	15	1330	75/1014	86	1050µF
RP20-483.3SFW	18-75	3.3	5500	30/461	84	18000µF
RP20-4805SFW	18-75	5	4000	30/508	86	9600µF
RP20-4812SFW	18-75	12	1670	40/515	85	1650µF
RP20-4815SFW	18-75	15	1330	40/507	86	1050µF
RP20-2405DFW	9-36	±5	±2000	85/1068	82	±4800µF
RP20-2412DFW	9-36	±12	±833	100/1028	85	±625µF
RP20-2415DFW	9-36	±15	±667	100/1017	86	±525µF
RP20-4805DFW	18-75	±5	±2000	45/534	82	±4800µF
RP20-4812DFW	18-75	±12	±833	50/514	85	±825µF
RP20-4815DFW	18-75	±15	±667	50/508	86	±525µF

- * no suffix for CTRL function with Positive Logic (1=ON, 0=OFF), this is standard
- * add /N for CTRL function with Negative Logic (0=ON, 1=OFF)
- * add suffix -HC for premounted heatsink and clips

Ordering Examples

RP20-2405SFW = 24V 4:1 Input, 5V Output, Positive Logic CTRL pin fitted

RP20-4812DFW/N-HC = 48V 4:1 Input, ±12V Output, Negative Logic CTRL pin fitted, Heatsink fitted

POWERLINE

DC/DC-Converter

with 3 year Warranty

RECOM

20 Watt 2" x 1" Single & Dual Output



**UL-60950-1 Certified
E196683**

RP20-FW

RP20-FW

Derating Graph (Ambient Temperature)

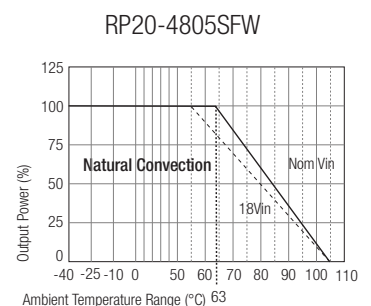

Derating graphs are valid only for the shown part numbers. If you need detailed derating information about a part number not shown here please contact our technical customer support at info@recom-development.at

Refer to Application Notes

Specifications (typical at nominal input and 25°C unless otherwise noted)

Input Voltage Range	24V nominal input	9-36VDC
	48V nominal input	18-75VDC
Input Filter		Pi Type
Input Surge Voltage (100 ms max.)	24V Input	50VDC
	48V Input	100VDC
Input Reflected Ripple (nominal Vin and full load)		20mA _{p-p}
Start Up Time (nominal Vin and constant resistor load)		20ms typ.
Remote ON/OFF ⁽¹⁾	DC-DC ON	Open or 3.0V < Vr < 12V
	DC-DC OFF	Short or 0V < Vr < 1.2V
Remote OFF input current	Nominal input	2.5mA
Output Power		20W max.
Output Voltage Accuracy (full Load and nominal Vin)		±1%
Minimum Load		0%
Line Regulation (low line, high line at full load)		±0.2%
Load Regulation (0% to 100% full load)	Single	±0.5%
	Dual	±1%
Cross Regulation Dual Output (asymmetrical load 25% <>100% load)		±5%
Ripple and Noise (20MHz bandwidth, with 1µF MLCC on output)	3.3V	60mV _{p-p}
	5.0, 12, 15V	75mV _{p-p}
	±5, ±12, ±15V	100mV _{p-p}
Temperature Coefficient		±0.02%/°C max.
Transient Response (25% load step change)		250µs
Input Voltage Variation, dv/dt	complies with ETS300 132, part 4.4	5V/ms
Over Load Protection (% of full load at nominal Vin)		150% typ
Overvoltage Protection (Single)		Zener Diode Clamp
Undervoltage Protection		See Application Notes
Short Circuit Protection		Continuous, automatic recovery
Efficiency		see „Selection Guide“ table
Isolation Voltage (rated for one minute)	In to Out and I/O to case	1600VDC
Isolation Resistance		10 GΩ min.
Isolation Capacitance		1500pF max.
Operating Frequency		400kHz typ.
Operating Temperature Range	no derating	-40°C to +63°C
	with derating	-40°C to +105°C
Maximum Case Temperature		+105°C
Storage Temperature Range		-55°C to +125°C
Thermal Impedance ⁽⁸⁾	Natural convection	12°C/Watt
	with Heatsink	10°C/Watt
Case Material		Nickel plated copper
Base Material		Non-conductive black plastic
Potting Material		Epoxy (UL94-V0)
Weight		27g
Packing Quantity	Refer to App Notes for tube dimensions	9 pcs per Tube

RP20-FW

continued on next page

Specifications (typical at nominal input and 25°C unless otherwise noted)

Conducted Emissions ⁽³⁾	EN55022	Class A
Radiated Emissions ⁽³⁾	EN55022	Class A
ESD	EN61000-4-2	Perf. Criteria B
Radiated Immunity	EN61000-4-3	Perf. Criteria A
Fast Transient	EN61000-4-4	Perf. Criteria B
Surge	EN61000-4-5	Perf. Criteria B
Conducted Immunity	EN61000-4-6	Perf. Criteria A
Thermal Shock		MIL-STD-810D
Vibration		10-55Hz, 10G, 30 Min. along X, Y and Z
Relative Humidity		5% to 95% RH
MTBF ⁽²⁾	Bellcore-TR-NWT-000332	2350 x 10 ³ hours
	MIL-HDBK-217F	659 x 10 ³ hours

Notes :

1. The RP20-S_DFW series requires a minimum of 10% loading on the output to maintain specified regulation. Operation under no-load condition will not damage these devices, however they may not meet all listed specification.
2. BELLCORE TR-NWT-000332. Case I: 50% Stress, Temperature at 40°C (Ground fixed and controlled environment).
3. Requires external filter to meet EN55022 Class A and B. Refer to Application Notes.
4. Typical value at nominal input voltage and no load.
5. Maximum value at nominal input voltage and full load.
6. Typical value at nominal input voltage and full load.
7. Test by minimum Vin and constant resistor load.
8. Optional Heatsink Part Number 7G-0020-C . Powerline DC/DC Converters can be ordered with pre-mounted heatsinks including antivibration fixing clips (add suffix -HC). See Application Notes for heatsink details.
9. The ON/OFF control function can be positive or negative logic. The pin voltage is referenced to negative input.
Positive logic ON/OFF is standard, no suffix (Ex. RP20-2405SF)
Negative logic ON/OFF is marked with suffix-N (Ex. RP20-2405SF/N).

Package Style and Pinning (mm)

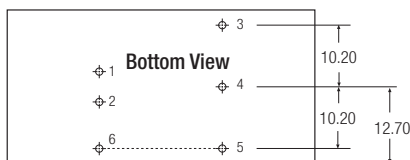
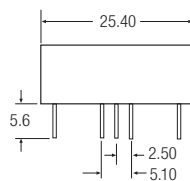
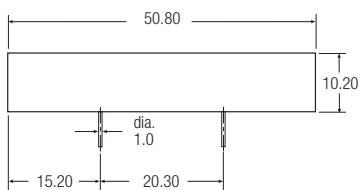

Pin Connections

Pin #	Single	Dual
1	+Vin	+Vin
2	-Vin	-Vin
3	+Vout	+Vout
4	Trim	Com
5	-Vout	-Vout
6	CTRL	CTRL

Pin Pitch Tolerance ±0.35 mm

External Output Trimming

Single Output can be trimmed ±10% by using external resistors
See Application Notes for details

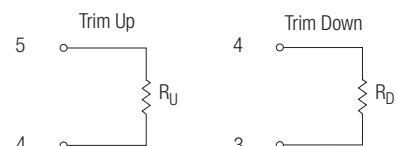

Features

- 2:1 Wide Input Voltage Range
- 30 Watts Output Power
- 1.6kVDC Isolation
- UL Certified
- Fixed Operating Frequency
- Six-Sided Continuous Shield
- International Safety Standard Approvals
- Standard 50.8 x 40.6 x 10.2mm Package
- Efficiency to 90 %
- Available as Power Module (RPM30-E)

Description

The RP30-E series DC/DC converters are certified to UL 60950-1 and cUL 60950-1. This makes them ideal for all telecom and industrial applications where approved safety standards are required. The industry standard 2" x 1.6" package meets military standards for thermal shock and vibration tolerance.

Selection Guide 12V, 24V and 48V Input Types

Part Number	Input Range VDC	Output Voltage VDC	Output Current mA	Input ⁽⁴⁾ Current mA	Efficiency ⁽⁵⁾ %	Capacitive ⁽⁶⁾ Load max.
RP30-123.3SE	9-18	3.3	6000	2037	85	19500µF
RP30-1205SE	9-18	5	6000	3012	87	10200µF
RP30-1212SE	9-18	12	2500	2976	88	3240µF
RP30-1215SE	9-18	15	2000	2976	88	1100µF
RP30-243.3SE	18-36	3.3	6000	1031	86	19500µF
RP30-2405SE	18-36	5	6000	1490	88	10200µF
RP30-2412SE	18-36	12	2500	1470	89	3300µF
RP30-2415SE	18-36	15	2000	1470	89	1100µF
RP30-483.3SE	36-75	3.3	6000	500	87	19500µF
RP30-4805SE	36-75	5	6000	740	89	10200µF
RP30-4812SE	36-75	12	2500	730	90	3300µF
RP30-4815SE	36-75	15	2000	730	90	1100µF
RP30-1212DE	9-18	±12	±1250	3012	87	±1020µF
RP30-1215DE	9-18	±15	±1000	3012	87	±675µF
RP30-2412DE	18-36	±12	±1250	1488	88	±1020µF
RP30-2415DE	18-36	±15	±1000	1488	88	±675µF
RP30-4812DE	36-75	±12	±1250	744	88	±1020µF
RP30-4815DE	36-75	±15	±1000	744	88	±675µF

* no suffix for CTRL function with Positive Logic (1=ON, 0=OFF), this is standard

* add suffix **-HC** for premounted heatsink and clips

Ordering Examples

RP30-2405SE = 24V Input, 5V Output, Positive Logic CTRL pin.

RP20-4812DE-HC = 48V Input, ±12V Output, Positive Logic CTRL pin, Heatsink fitted

Derating graphs are valid only for the shown part numbers. If you need detailed derating-information about a part-number not shown here please contact our technical support service at info@recom-development.at

POWERLINE

DC/DC-Converter

with 3 year Warranty

RECOM

30 Watt Single & Dual Output

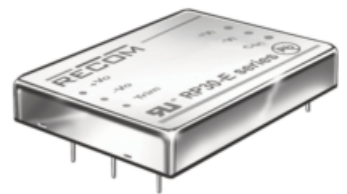

UL-60950-1 Certified
E196683

RP30-E

Derating Graph (Ambient Temperature)

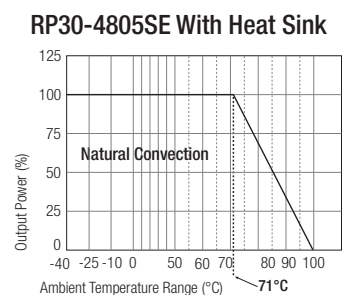
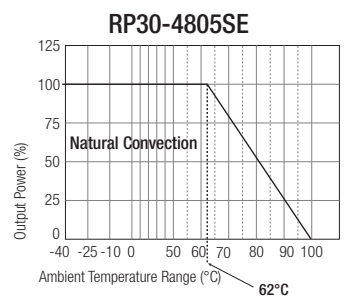

Refer to Application Notes

Typical Characteristics

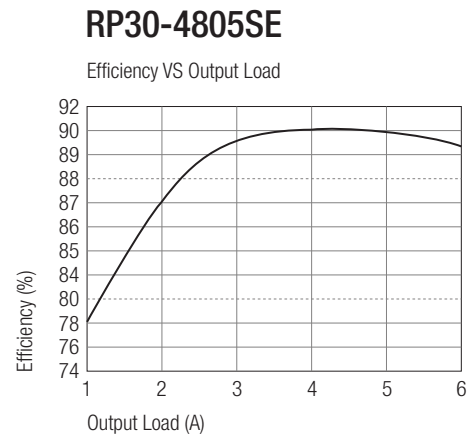
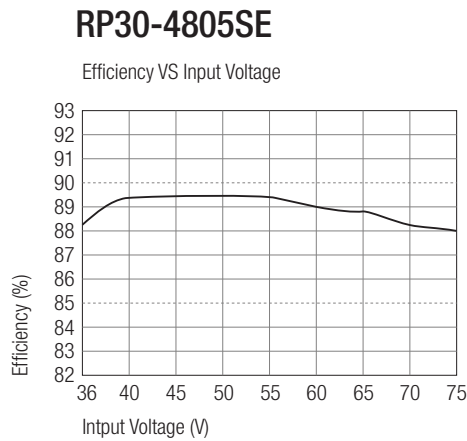

Specifications (typical at nominal input and 25°C unless otherwise noted)

Input Voltage Range	12V nominal input	9-18VDC	
	24V nominal input	18-36VDC	
	48V nominal input	36-75VDC	
Under Voltage Lockout	12V input	DC-DC ON	9VDC
		DC-DC OFF	8VDC
	24V input	DC-DC ON	17.8VDC
		DC-DC OFF	16VDC
	48V input	DC-DC ON	36VDC
		DC-DC OFF	33VDC
Input Filter ⁽¹⁾		L-C Type	
Input Voltage Variation dv/dt	(Complies with ETS300 132 part 4.4)	5V/ms max	
Input Surge Voltage (100 ms max.)	12V Input	36VDC	
	24V Input	50VDC	
	48V Input	100VDC	
Input Reflected Ripple (nominal Vin and full load) ⁽³⁾		30mA _{p-p}	
Start Up Time (nominal Vin and constant resistor load)		25ms typ.	
Remote ON/OFF ⁽⁷⁾	DC-DC ON	Open or 3.0V < Vr < 12V	
	DC-DC OFF	Short or 0V < Vr < 1.2V	
Remote OFF input current	Nominal input	2.5mA	
Output Power		30W max.	
Output Voltage Accuracy (full Load and nominal Vin)		±1%	
Voltage Adjustability		±10%	
Minimum Load	Single & Dual	0%	
Line Regulation (low line, high line at full load)	Single	±0.2%	
	Dual	±0.5%	

continued on next page

Specifications (typical at nominal input and 25°C unless otherwise noted)

Load Regulation (25% to 100% full load)	Single	±0.5%
	Dual	±1%
Cross Regulation (Asymmetrical 25% <> 100% load)	Dual	±5%
Ripple and Noise (20MHz bandwidth, with 1µF MLCC on output) (Measured with a 1004pF/50V MLCC)	Single 3.3, 5V	50mVp-p
	Single 12, 15V	75mVp-p
	Dual 5, 12, 15V	100mVp-p
Temperature Coefficient		±0.02%/°C max.
Transient Response (25% load step change)		300µs
Over Voltage Protection	3.3V	3.9V
Zener diode clamp (only single)	5V	6.2V
	12V	15V
	15V	18V
Over Load Protection (% of full load at nominal Vin)		150% typ
Undervoltage Lockout		See Application Notes
Short Circuit Protection		Hiccup, automatic recovery
Efficiency		see „Selection Guide“ table
Isolation Voltage (rated for one minute)		1600VDC
Isolation Resistance		1 GΩ min.
Isolation Capacitance		1000pF max.
Operating Frequency		300kHz typ.
Approved to Safety Standards		UL 1950, EN60950
Operating Temperature Range		-40°C to +85°C(with derating)
Maximum Case Temperature		+100°C
Storage Temperature Range		-55°C to +125°C
Over Temperature Protection		115°C typ.
Thermal Impedance ⁽⁸⁾	Natural convection	10°C/Watt
	Natural convection with Heat Sink	8.24°C/Watt
Thermal Shock		MIL-STD-810D
Vibration		10-55Hz, 10G, 30 Min. along X, Y and Z
Relative Humidity		5% to 95% RH
Case Material		Nickel plated copper
Base Material		Non-conductive black plastic
Potting Material		Epoxy (UL94-V0)
Weight		48g
Packing Quantity	Refer to App Notes for tube dimensions	5 pcs per Tube
Dimensions		50.8 x 40.6 x 10.2mm
Conducted Emissions ⁽⁹⁾	EN55022	Class A
Radiated Emissions	EN55022	Class A
ESD	EN61000-4-2	Perf. Criteria B
Radiated Immunity	EN61000-4-3	Perf. Criteria B
Fast Transient	EN61000-4-4	Perf. Criteria B
Surge	EN61000-4-5	Perf. Criteria B
Conducted Immunity	EN61000-4-6	Perf. Criteria B
MTBF ⁽²⁾		1535 x 10 ³ hours

Notes :

1. An external filter capacitor is required for normal operation. The capacitor should be capable of handling 1A ripple current for 48V/24V models. RECOM suggest: Nippon chemi-con KY series, 220 μ F/100V, ESR 90m Ω .
2. BELLCORE TR-NWT-000332. Case I: 50% Stress, Temperature at 40°C (Ground fixed and controlled environment).
3. Simulated source impedance of 12 μ H. 12 μ H inductor in series with +Vin.
4. Maximum value at nominal input voltage and full load of standard type.
5. Typical value at nominal input voltage and full load.
6. Test by minimum Vin and constant resistor load.
7. The ON/OFF control pin voltage is referenced to negative input
8. Heat sink is optional and P/N: 7G-0011-C. Powerline DC/DC Converters can be ordered with pre-mounted heatsinks including antivibration fixing clips (add suffix -HC). See Application Notes for heatsink details.
9. See application notes for Class B common mode filter suggestion.

Package Style and Pinning (mm)

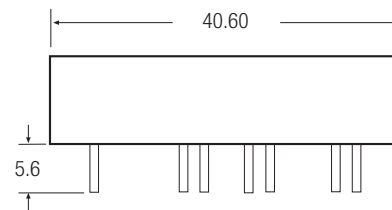
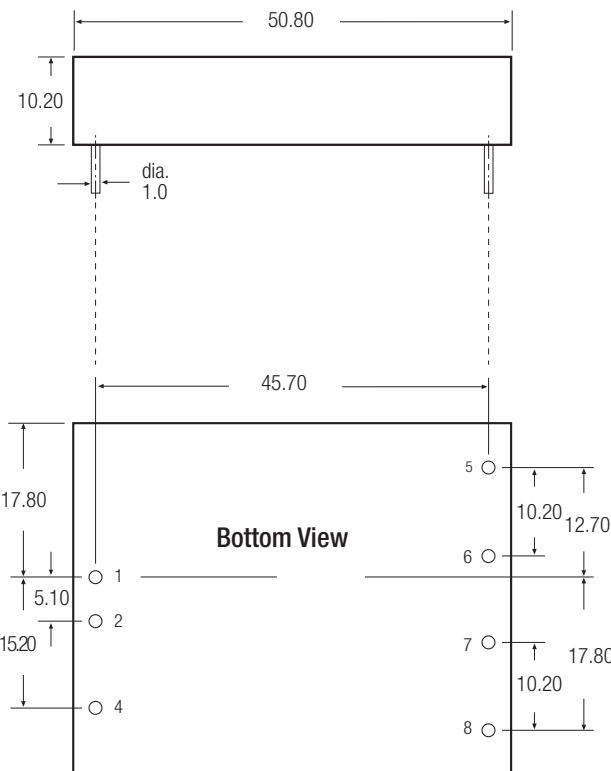

Pin Connections

Pin #	Single	Dual
1	+Vin	+Vin
2	-Vin	-Vin
4	CTRL	CTRL
5	No Pin	+Vout
6	+Vout	Com
7	-Vout	-Vout
8	Trim	Trim

Pin Pitch Tolerance ± 0.35 mm

External Output Trimming

Output can be externally trimmed by using the method shown below. () for dual output trim. See Application Notes for details.

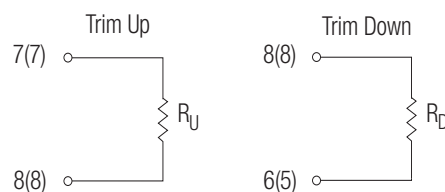

Features

- 4:1 Wide Input Voltage Range
- 30 Watts Output Power
- 1.6kVDC Isolation
- UL Certified
- Fixed Operating Frequency
- Six-Sided Continuous Shield
- Standard 50.8 x 40.6 x 10.2mm Package
- Efficiency to 88 %
- Available as Power Module (RPM30-EW)

Description

The RP30-EW series wide input range DC/DC converters are certified to UL 60950-1 and to cUL 60950-1. This makes them ideal for all telecom and industrial applications where approved safety standards are required. The industry standard 2" x 1.6" package meets military standards for thermal shock and vibration tolerance.

Selection Guide 24V and 48V Input Types

Part Number	Input Range VDC	Output Voltage VDC	Output Current mA	Input ⁽⁴⁾ Current mA	Efficiency ⁽⁵⁾ %	Capacitive ⁽⁶⁾ Load max.
RP30-243.3SEW	10-40	3.3	6000	994	87	19500µF
RP30-2405SEW	10-40	5	6000	1506	87	10200µF
RP30-2412SEW	10-40	12	2500	1506	87	3300µF
RP30-2415SEW	10-40	15	2000	1488	88	1100µF
RP30-483.3SEW	18-75	3.3	6000	497	87	19500µF
RP30-4805SEW	18-75	5	6000	744	88	10200µF
RP30-4812SEW	18-75	12	2500	753	87	3300µF
RP30-4815SEW	18-75	15	2000	744	88	1100µF
RP30-2412DEW	10-40	±12	±1250	1563	84	±1000µF
RP30-2415DEW	10-40	±15	±1000	1543	86	±680µF
RP30-4812DEW	18-75	±12	±1250	772	85	±1000µF
RP30-4815DEW	18-75	±15	±1000	762	86	±680µF

* no suffix for CTRL function with Positive Logic (1=ON, 0=OFF), this is standard

* add /N for CTRL function with Negative Logic (0=ON, 1=OFF)

* add suffix -HC for premounted heatsink and clips

Ordering Examples

RP30-2405SEW = 24V Input, 5V Output, Positive Logic CTRL pin.

RP20-4812DEW/N-HC = 48V Input, ±12V Output, Negative Logic CTRL pin, Heatsink fitted

Derating graphs are valid only for the shown part numbers. If you need detailed derating-information about a part-number not shown here please contact our technical support service at info@recom-development.at

POWERLINE

DC/DC-Converter

with 3 year Warranty

RECOM

30 Watt Single & Dual Output



**UL-60950-1 Certified
E196683**

RP30-EW

Derating Graph (Ambient Temperature)

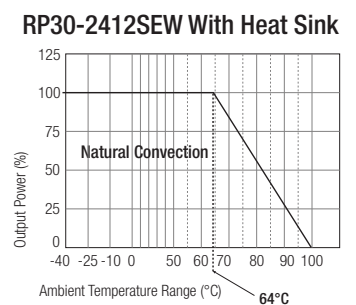
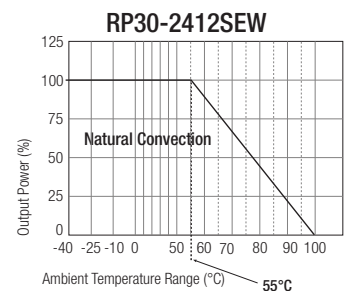

Refer to Application Notes

Typical Characteristics

RP30-483.3SEW

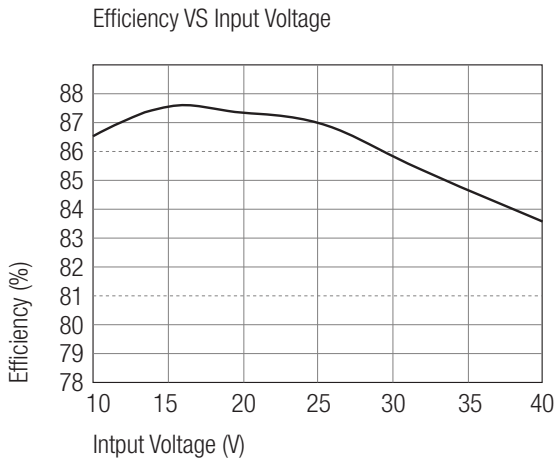

RP30-483.3SEW

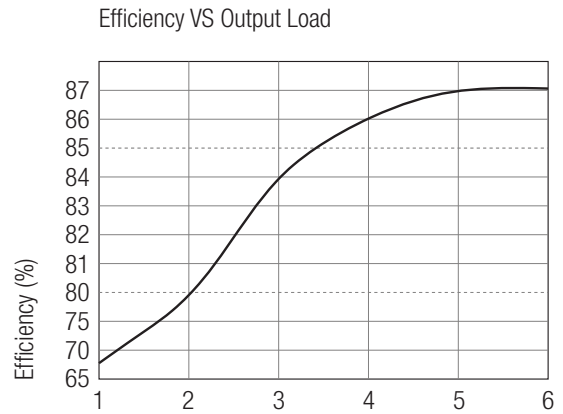

Specifications (typical at nominal input and 25°C unless otherwise noted)

Input Voltage Range	24V nominal input	10-40VDC	
	48V nominal input	18-75VDC	
Under Voltage Lockout	24V input	DC-DC ON	10VDC
		DC-DC OFF	8VDC
	48V input	DC-DC ON	18VDC
		DC-DC OFF	16VDC
Input Filter ⁽¹⁾		L-C Type	
Input Voltage Variation dv/dt	(Complies with ETS300 132 part 4.4)	5V/ms max	
Input Surge Voltage (100 ms max.)	24V Input	50VDC	
	48V Input	100VDC	
Input Reflected Ripple (nominal Vin and full load) ⁽³⁾		20mA _{p-p}	
Start Up Time (nominal Vin and constant resistor load)		10ms typ.	
Remote ON/OFF ⁽⁷⁾	DC-DC ON	Open or 3.0V < Vr < 12V	
	DC-DC OFF	Short or 0V < Vr < 1.2V	
Remote OFF input current	Nominal input	3mA	
Output Power		30W max.	
Output Voltage Accuracy (full Load and nominal Vin)		±1%	
Voltage Adjustability		±10%	
Minimum Load	Single	0%	
	Dual	10% of full load	
Line Regulation (low line, high line at full load)		±0.5%	
Load Regulation (25% to 100% full load) ⁽⁹⁾	Single	±0.5%	
	Dual	±1%	
Cross Regulation (Asymmetrical 25% <> 100% load)	Dual	±5%	

continued on next page

Specifications (typical at nominal input and 25°C unless otherwise noted)

Ripple and Noise (20MHz bandwidth, with 1µF MLCC on output) (Measured with a 100nF/50V MLCC)	Single 3.3V	60mVp-p
	Single 5V	75mVp-p
	Single 12, 15V	100mVp-p
	Dual 12, 15V	100mVp-p
Temperature Coefficient		±0.02%/°C max.
Transient Response (25% load step change)		250µs
Over Voltage Protection	3.3V	3.9V
Zener diode clamp	5V	6.2V
	12V	15V
	15V	18V
Over Load Protection (% of full load at nominal Vin)		150% max.
Undervoltage Lockout		See Application Notes
Short Circuit Protection		Hiccup, automatic recovery
Efficiency		see „Selection Guide“ table
Isolation Voltage (rated for one minute)		1600VDC
Isolation Resistance		1 GΩ min.
Isolation Capacitance		1000pF max.
Operating Frequency		300kHz typ.
Approved to Safety Standards		EN60950
Operating Temperature Range		-40°C to +85°C(with derating)
Maximum Case Temperature		+100°C
Storage Temperature Range		-55°C to +125°C
Over Temperature Protection		115°C typ.
Thermal Impedance ⁽⁸⁾	Natural convection	10°C/Watt
	Natural convection with Heat Sink	8.24°C/Watt
Thermal Shock		MIL-STD-810F
Vibration		10-55Hz, 10G, 30 Min. along X, Y and Z
Relative Humidity		5% to 95% RH
Case Material		Nickel plated copper
Base Material		Non-conductive black plastic
Potting Material		Epoxy (UL94-V0)
Weight		48g
Packing Quantity	Refer to App Notes for tube dimensions	5 pcs per Tube
Dimensions		50.8 x 40.6 x 10.2mm
Conducted Emissions ⁽¹⁰⁾	EN55022	Class A
Radiated Emissions	EN55022	Class A
ESD	EN61000-4-2	Perf. Criteria B
Radiated Immunity	EN61000-4-3	Perf. Criteria A
Fast Transient	EN61000-4-4	Perf. Criteria B
Surge	EN61000-4-5	Perf. Criteria B
Conducted Immunity	EN61000-4-6	Perf. Criteria A
MTBF ⁽²⁾		1315 x 10 ³ hours

Notes :

1. An external filter capacitor is required for normal operation. The capacitor should be capable of handling 1A ripple current for 48V/24V models. RECOM suggest: Nippon chemi-con KY series, 220 μ F/100V, ESR 90m Ω .
2. BELLCORE TR-NWT-000332. Case I: 50% Stress, Temperature at 40°C (Ground fixed and controlled environment).
3. Simulated source impedance of 12 μ H. 12 μ H inductor in series with +Vin.
4. Maximum value at nominal input voltage and full load of standard type.
5. Typical value at nominal input voltage and full load.
6. Test by minimum Vin and constant resistor load.
7. The ON/OFF control function can be positive or negative logic. The pin voltage is referenced to negative input.
 - Positive logic ON/OFF is standard, no suffix (Ex. RP30-2405SEW)
 - Negative logic ON/OFF is marked with suffix-N (Ex. RP30-2405SEW/N).
8. Heat sink is optional and P/N: 7G-0011-C. Powerline DC/DC Converters can be ordered with pre-mounted heatsinks including antivibration fixing clips (add suffix -HC). See Application Notes for heatsink details.
9. The dual output required a minimum 10% loading on the output to maintain specified regulation. Operation under no-load condition will not damage these devices, however they may not meet all listed specification.
10. See application notes for class B common mode filter suggestion.

Package Style and Pinning (mm)

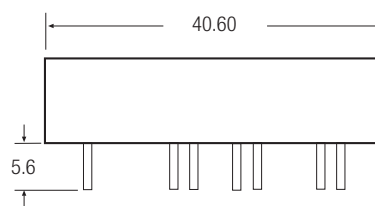
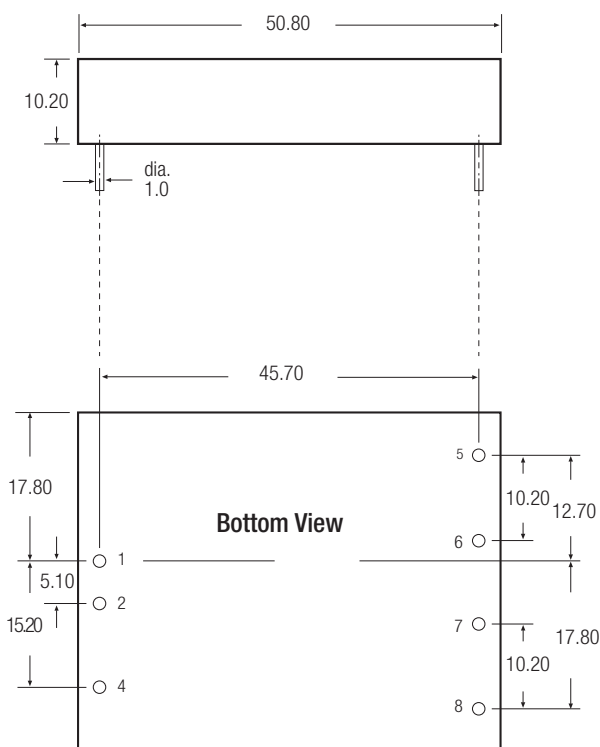

Pin Connections

Pin #	Single	Dual
1	+Vin	+Vin
2	-Vin	-Vin
4	CTRL	CTRL
5	No Pin	+Vout
6	+Vout	Com
7	-Vout	-Vout
8	Trim	Trim

Pin Pitch Tolerance ± 0.35 mm

External Output Trimming

Output can be externally trimmed by using the method shown below. () for dual output trim. See Application Notes for details.

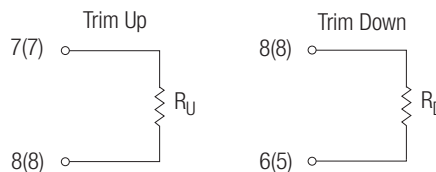

Features

- 2:1 Wide Input Voltage Range
- 30 Watts Output Power
- 1.6kVDC Isolation
- UL Pending
- Fixed Operating Frequency
- Six-Sided Continuous Shield
- Standard 50.8 x25.4x10.2mm Package
- Efficiency to 91%

Description

The RP30-F series DC/DC converters are designed to meet to UL 60950-1 and to cUL 60950-1.

This makes them ideal for all telecom and industrial applications where approved safety standards are required.

The industry standard 2" x 1" package meets military standards for thermal shock and vibration tolerance.

Selection Guide 12V, 24V and 48V Input Types

Part Number	Input Range VDC	Output Voltage VDC	Output Current mA	Input Current ⁽⁴⁾ mA		Efficiency ⁽⁵⁾ %	Capacitive Load max. ⁽⁶⁾ μ F
				No Load	Full Load		
RP30-123.3SF	9-18	3.3	8000	90	2716	85	20000 μ F
RP30-1205SF	9-18	5	6000	130	3012	87	14400 μ F
RP30-1212SF	9-18	12	2500	90	2941	89	3000 μ F
RP30-1215SF	9-18	15	2000	80	2941	89	2000 μ F
RP30-243.3SF	18-36	3.3	8000	50	1325	87	20000 μ F
RP30-2405SF	18-36	5	6000	75	1453	90	14400 μ F
RP30-2412SF	18-36	12	2500	40	1437	91	3000 μ F
RP30-2415SF	18-36	15	2000	30	1437	91	2000 μ F
RP30-483.3SF	36-75	3.3	8000	30	663	87	20000 μ F
RP30-4805SF	36-75	5	6000	45	727	90	14400 μ F
RP30-4812SF	36-75	12	2500	40	718	91	3000 μ F
RP30-4815SF	36-75	15	2000	40	718	91	2000 μ F
RP30-1205DF	9-18	\pm 5	\pm 3000	90	3012	87	\pm 3000 μ F
RP30-1212DF	9-18	\pm 12	\pm 1250	50	3012	87	\pm 2000 μ F
RP30-1215DF	9-18	\pm 15	\pm 1000	40	3012	87	\pm 1300 μ F
RP30-2405DF	18-36	\pm 5	\pm 3000	70	1453	90	\pm 3000 μ F
RP30-2412DF	18-36	\pm 12	\pm 1250	30	1471	89	\pm 2000 μ F
RP30-2415DF	18-36	\pm 15	\pm 1000	30	1453	90	\pm 1300 μ F
RP30-4805DF	36-75	\pm 5	\pm 3000	35	727	90	\pm 3000 μ F
RP30-4812DF	36-75	\pm 12	\pm 1250	30	744	88	\pm 2000 μ F
RP30-4815DF	36-75	\pm 15	\pm 1000	20	735	89	\pm 1300 μ F

* no suffix for CTRL function with Positive Logic (1=ON, 0=OFF), this is standard

* add /N for CTRL function with Negative Logic (0=ON, 1=OFF)

* add suffix -HC for premounted heatsink and clips

Ordering Examples

RP30-2405SF = 24V Input, 5V Output, Positive Logic CTRL pin fitted

RP30-4812DF/N-HC = 48V Input, \pm 12V Output, Negative Logic CTRL pin fitted, Heatsink fitted

Derating graphs are valid only for the shown part numbers. If you need detailed derating-information about a part-number not shown here please contact our technical support service at info@recom-development.at

POWERLINE

DC/DC-Converter

with 3 year Warranty

RECOM

30 Watt 2" x 1" Package Single & Dual Output



**UL-60950-1 Certified
E196683**

RP30-F

Derating Graph (Ambient Temperature)

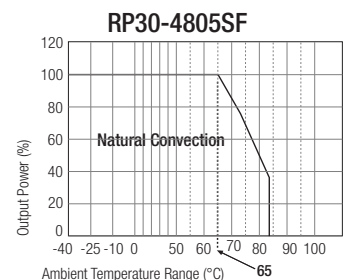

RP30-4805SF With Heat Sink

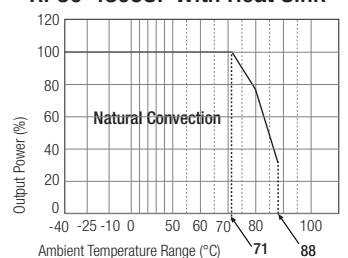

Refer to Application Notes

Typical Characteristics

RP30-4805SF

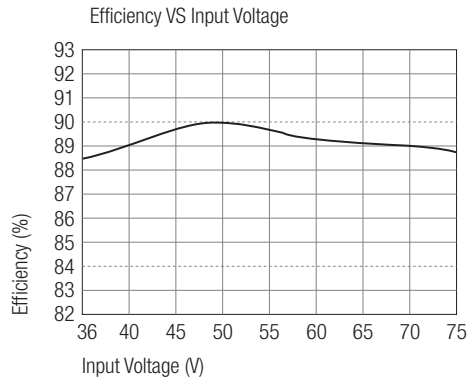

RP30-4805SF

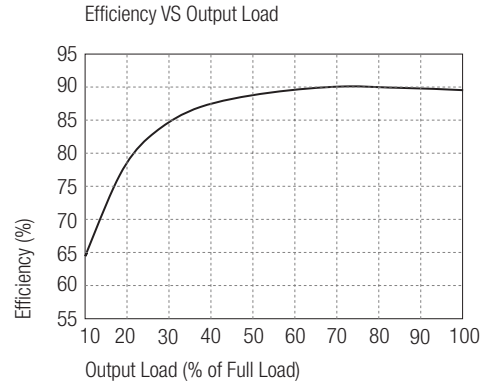

Specifications (typical at nominal input and 25°C unless otherwise noted)

Input Voltage Range	12V nominal input	9-18VDC
	24V nominal input	18-36VDC
	48V nominal input	36-75VDC
Input Filter		Pi Type
Input Surge Voltage (100 ms max.)	12V Input	25VDC
	24V Input	50VDC
	48V Input	100VDC
Input Reflected Ripple (nominal Vin and full load) ⁽³⁾		20mA _{p-p}
Start Up Time (nominal Vin and constant resistor load)	Power up	30ms typ.
	Remote ON/OFF	30ms typ.
Start-up voltage	12V Input	9VDC
	24V Input	18VDC
	48V Input	36VDC
Shutdown voltage	12V Input	8VDC
	24V Input	16VDC
	48V Input	32VDC
Remote ON/OFF ⁽⁷⁾ (Positive logic)(Standard)	DC-DC ON	Open or 3V < Vr < 12V
	DC-DC OFF	Short or 0V < Vr < 1.2V
(Negative logic)(Option)	DC-DC ON	Short or 0V < Vr < 1.2V
	DC-DC OFF	Open or 3V < Vr < 12V
Input current of Remote control pin	Nominal input	-0.5mA ~ +0.5mA
Remote OFF state input current	Nominal input	3mA
Output Power		30W max.
Output Voltage Accuracy (full Load and nominal Vin)		±1%
Voltage Adjustability		±10%
Minimum Load		0%
Line Regulation (low line, high line at full load)		±0.2%

continued on next page

Specifications (typical at nominal input and 25°C unless otherwise noted)

Load Regulation (No load to full load)	Single Dual	±0.5% ±1%
Cross Regulation (asymmetrical 25% <>100% load)	Dual	±5%
Ripple and Noise (20MHz bandwidth, with 1µF MLCC on output) (Measured with a 1µF/50V MLCC)	3.3, 5V 12, 15V	100mVp-p 150mVp-p
Temperature Coefficient		±0.02%/°C max.
Transient Response (25% load step change)		250µs
Over Voltage Protection	3.3V	3.9V
Zener diode clamp (only single)	5V, ±5V 12V, ±12V 15V, ±15V	6.2V 15V 18V
Over Load Protection (% of full load at nominal Vin)		150% typ
Short Circuit Protection		Hiccup, automatic recovery
Efficiency		see „Selection Guide“ table
Isolation Voltage (rated for one minute)	Input to Output Input (Output) to case	1600VDC 1600VDC
Isolation Resistance		1GΩ min.
Isolation Capacitance		1500pF max.
Operating Frequency		430kHz typ.
Operating Temperature Range		-40°C to +50°C(without derating) -40°C to +85°C(with derating)
Maximum Case Temperature		+105°C
Storage Temperature Range		-55°C to +125°C
Over Temperature Protection		+115°C typ.
Thermal Impedance ⁽⁸⁾	Natural convection Natural convection with Heat Sink	12°C/Watt 10°C/Watt
Thermal Shock		MIL-STD-810F
Vibration		MIL-STD-810F
Relative Humidity		5% to 95% RH
Case Material		Nickel plated copper
Base Material		FR4 PCB
Potting Material		Epoxy (UL94-V0)
Conducted Emissions ⁽¹⁰⁾	EN55022	Class A
Radiated Emissions	EN55022	Class B
ESD	EN61000-4-2	Air ±8KV Perf. Criteria A
	EN61000-4-2	Contact ±6KV Perf. Criteria A
Radiated Immunity	EN61000-4-3	10V/m Perf. Criteria A
Fast Transient ⁽⁹⁾	EN61000-4-4	±2KV Perf. Criteria A
Surge ⁽⁹⁾	EN61000-4-5	±1KV Perf. Criteria A
Conducted Immunity	EN61000-4-6	10 Vr.m.s Perf. Criteria A
Weight		30.5g
Packing Quantity	Refer to App Notes for tube dimensions	9 pcs per Tube
Dimensions		50.8 x 25.4 x 10.2mm
MTBF ⁽²⁾	Belcore-TR-NWT-000332	3.173 x 10 ⁶ hours
	MIL-HDBK-217F	5.548 x 10 ⁵ hours

Notes :

1. The RP30-S_DF series does not require any minimum load.
2. BELLCORE TR-NWT-000332. Case I: 50% Stress, Temperature at 40°C (Ground fixed and controlled environment)
MIL-HDBK-217F Notice2 @ TA= 25°C, Full load (Ground, Begign, controlled environment)
3. Simulated source impedance of 12μH. 12μH inductor in series with +Vin.
4. Typical value at nominal input voltage and no load of standard type
Maximum value at nominal input voltage and full load of standard type.
5. Typical value at nominal input voltage and full load.
6. Test by minimum Vin and constant resistor load.
7. The ON/OFF control function can be positive or negative logic. The pin voltage is referenced to negative input.
Positive logic ON/OFF is standard, no suffix (Ex. RP30-2405SF)
Negative logic ON/OFF is marked with suffix-N (Ex. R320-2405SF/N).
8. Heat sink is optional and P/N: 7G-0020-C . Powerline DC/DC Converters can be ordered with pre-mounted heatsinks including antivibration fixing clips (add suffix -HC). See Application Notes for heatsink details.
9. An external filter capacitor is required if the module has to meet EN61000-4-4,EN61000-4-5.
The filter capacitor RECOM suggest: 12Vin & 24Vin : Nippon chemi-con KY series, 330μF/50V, ESR 55mΩ.
48Vin : Nippon chemi-con KY series, 220μF/100V, ESR 48mΩ.
10. Meets class A with external components shown below. See application notes for Class B common mode filter suggestion

Package Style and Pinning (mm)

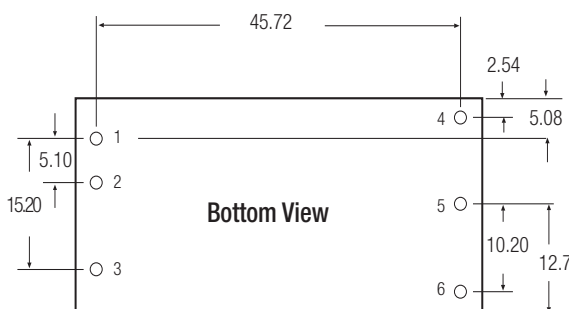
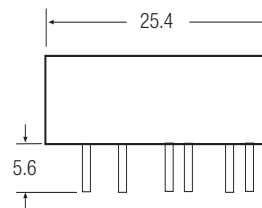
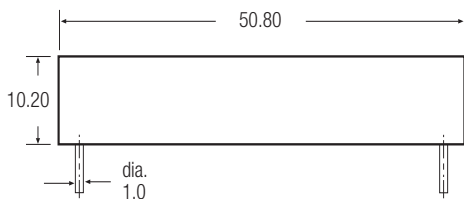

Pin Connections

Pin #	Single	Dual
1	+Vin	+Vin
2	-Vin	-Vin
3	CTRL	CTRL
4	+Vout	+Vout
5	-Vout	Com
6	Trim	-Vout

Pin Pitch Tolerance ±0.25 mm

EMC Filtering - For Class A filter suggestion, see Application Notes

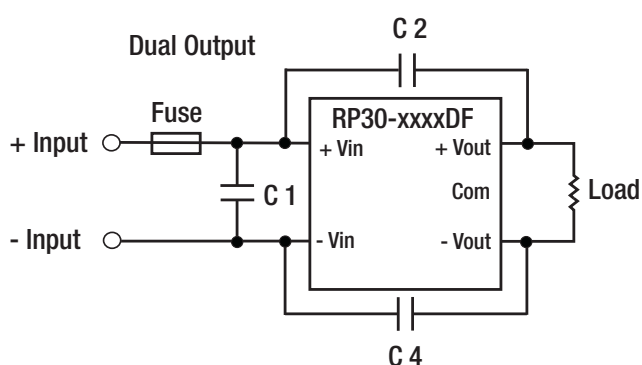
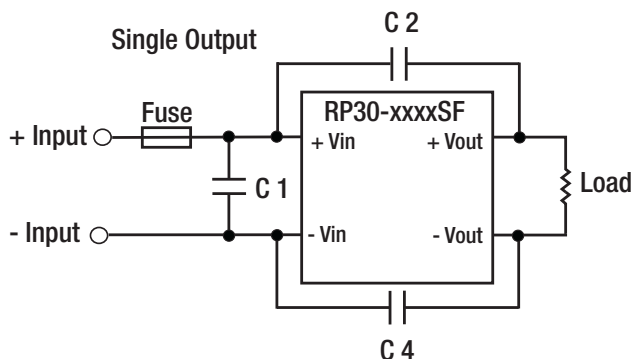

Single Output	C1	C2 & C3
RP30-12xxSF	10 μ F/25V 1812 MLCC	1000pF/2KV 1808 MLCC
RP30-24xxSF	6.8 μ F/50V 1812 MLCC	1000pF/2KV 1808 MLCC
RP30-48xxSF	2.2 μ F/100V 1812 MLCC	1000pF/2KV 1808 MLCC

Dual Output	C1	C2 & C4
RP30-12xxDF	10 μ F/25V 1812 MLCC	1000pF/2KV 1808 MLCC
RP30-24xxDF	6.8 μ F/50V 1812 MLCC	1000pF/2KV 1808 MLCC
RP30-48xxDF	2.2 μ F/100V 1812 MLCC	1000pF/2KV 1808 MLCC

Recommended EN55022 Class A Filter Circuit Layouts

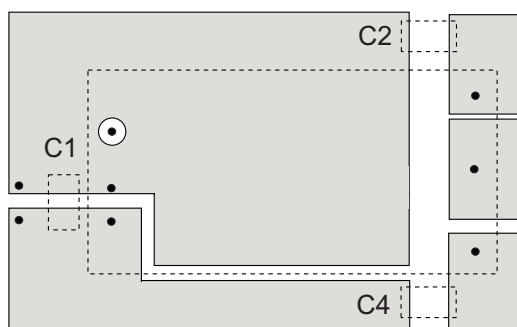
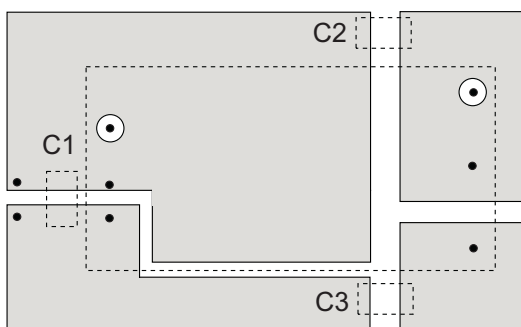

External Output Trimming

Output can be externally trimmed by using the method shown below. See Application Notes for details.

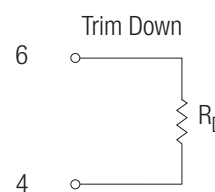
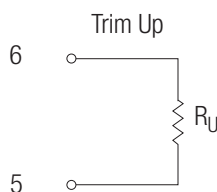

The product information and specifications are subject to change without prior notice. All products are designed for non-safety critical commercial and industrial applications. The Buyer agrees to implement safeguards that anticipate the consequences of any failures that might cause harm, loss of life and/or damage property.

Features

- 4:1 Wide Input Voltage Range
- 30 Watts Output Power
- 1.6kVDC Isolation
- UL Certified
- Fixed Operating Frequency
- Six-Sided Continuous Shield
- Standard 50.8 x25.4x10.2mm Package
- Efficiency to 91%

Description

The RP30-FW series DC/DC converters are designed to meet to UL 60950-1 and to cUL 60950-1.

This makes them ideal for all telecom and industrial applications where approved safety standards are required.

The industry standard 2" x 1" package meets military standards for thermal shock and vibration tolerance.

Selection Guide 24V and 48V Input Types

Part Number	Input Range	Output Voltage	Output Current	Input Current ⁽⁴⁾		Efficiency ⁽⁵⁾	Capacitive ⁽⁶⁾ Load max.
	VDC	VDC	mA	No Load	Full Load		
RP30-243.3SFW	9-36	3.3	7500	70	1258	86	20000µF
RP30-2405SFW	9-36	5	6000	105	1488	88	14400µF
RP30-2412SFW	9-36	12	2500	20	1471	89	3000µF
RP30-2415SFW	9-36	15	2000	30	1471	89	2000µF
RP30-483.3SFW	18-75	3.3	7500	45	629	86	20000µF
RP30-4805SFW	18-75	5	6000	65	744	88	14400µF
RP30-4812SFW	18-75	12	2500	60	727	90	3000µF
RP30-4815SFW	18-75	15	2000	50	718	91	2000µF
RP30-2405DFW	9-36	±5	±3000	90	1488	88	±3000µF
RP30-2412DFW	9-36	±12	±1250	25	1506	87	±2000µF
RP30-2415DFW	9-36	±15	±1000	25	1506	87	±1300µF
RP30-4805DFW	18-75	±5	±3000	50	744	88	±3000µF
RP30-4812DFW	18-75	±12	±1250	15	744	88	±2000µF
RP30-4815DFW	18-75	±15	±1000	15	744	88	±1300µF

* no suffix for CTRL function with Positive Logic (1=ON, 0=OFF), this is standard

* add **N** for CTRL function with Negative Logic (0=ON, 1=OFF)

* add suffix **-HC** for premounted heatsink and clips

Ordering Examples

RP30-2405SFW = 24V Input, 5V Output, Positive Logic CTRL pin fitted

RP30-4812DFW/N-HC = 48V Input, ±12V Output, Negative Logic CTRL pin fitted, Heatsink fitted

Derating graphs are valid only for the shown part numbers. If you need detailed derating-information about a part-number not shown here please contact our technical support service at info@recom-development.at

POWERLINE

DC/DC-Converter

with 3 year Warranty

RECOM

30 Watt 2" x 1" Single & Dual Output

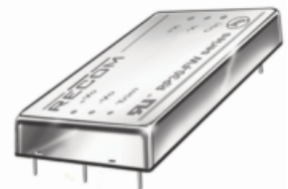

UL-60950-1 Certified

RP30-FW

Derating Graph (Ambient Temperature)

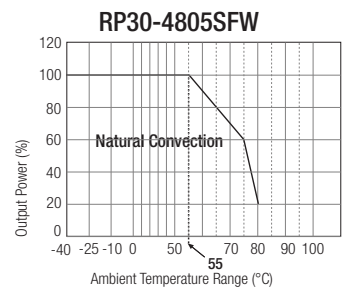

RP30-4805SFW With Heat Sink

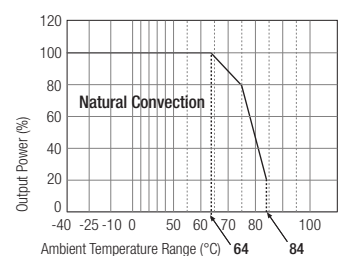

Refer to Application Notes

Typical Characteristics

RP30-4805SFV

Efficiency VS Input Voltage

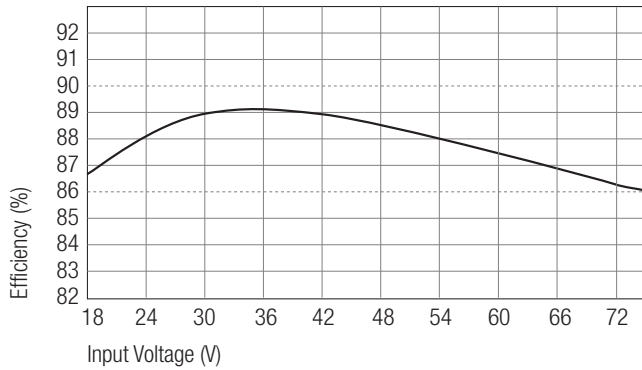

RP30-4805SFV

Efficiency VS Output Load

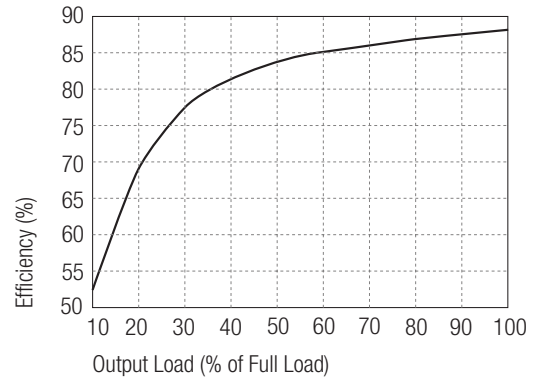

Specifications (typical at nominal input and 25°C unless otherwise noted)

Input Voltage Range	24V nominal input	9-36VDC
	48V nominal input	18-75VDC
Input Filter		Pi Type
Input Surge Voltage (100 ms max.)	24V Input	50VDC
	48V Input	100VDC
Input Reflected Ripple (nominal Vin and full load) ⁽³⁾		20mAp-p
Start Up Time (nominal Vin and constant resistor load)	Power up	30ms typ.
	Remote ON/OFF	30ms typ.
Start-up voltage	24V Input	9VDC
	48V Input	18VDC
Shutdown voltage	24V Input	8VDC
	48V Input	16VDC
Remote ON/OFF ⁽⁷⁾		
(Positive logic)(Standard)	DC-DC ON	Open or 3V < Vr < 12V
	DC-DC OFF	Short or 0V < Vr < 1.2V
(Negative logic)(Option)	DC-DC ON	Short or 0V < Vr < 1.2V
	DC-DC OFF	Open or 3V < Vr < 12V
Input current of Remote control pin	Nominal input	-0.5mA ~ +0.5mA
Remote OFF state input current	Nominal input	3mA
Output Power		30W max.
Output Voltage Accuracy (full Load and nominal Vin)		±1%
Voltage Adjustability		±10%
Minimum Load		0%
Line Regulation (low line, high line at full load)		±0.2%

continued on next page

Specifications (typical at nominal input and 25°C unless otherwise noted)

Load Regulation (No load to full load)	Single	±0.5%
	Dual	±1%
Cross Regulation (asymmetrical 25% <>100% load)	Dual	±5%
Temperature Coefficient		±0.02%/°C max.
Transient Response (25% load step change)		250µs
Over Voltage Protection	3.3V	3.9V
Zener diode clamp (only single)	5V, ±5V	6.2V
	12V, ±12V	15V
	15V, ±15V	18V
Over Load Protection (% of full load at nominal Vin)		150% typ
Short Circuit Protection		Hiccup, automatic recovery
Efficiency		see „Selection Guide“ table
Isolation Voltage (rated for one minute)	Input to Output	1600VDC
	Input (Output) to case	1600VDC
Isolation Resistance		1GΩ min.
Isolation Capacitance		1500pF max.
Operating Frequency		430kHz typ.
Operating Temperature Range		-40°C to +50°C(without derating)
		-40°C to +85°C(with derating)
Maximum Case Temperature		+105°C
Storage Temperature Range		-55°C to +125°C
Over Temperature Protection		+115°C typ.
Thermal Impedance ⁽⁸⁾	Natural convection	12°C/Wat
	Natural convection with Heat Sink	10°C/Watt
Thermal Shock		MIL-STD-810F
Vibration		MIL-STD-810F
Relative Humidity		5% to 95% RH
Case Material		Nickel plated copper
Base Material		FR4 PCB
Potting Material		Epoxy (UL94-V0)
Conducted Emissions ⁽¹⁰⁾	EN55022	Class A
Radiated Emissions	EN55022	Class B
ESD	EN61000-4-2	Air ±8KV Perf. Criteria A
	EN61000-4-2	Contact ±6KV Perf. Criteria A
Radiated Immunity	EN61000-4-3	10V/m Perf. Criteria A
Fast Transient ⁽⁹⁾	EN61000-4-4	±2KV Perf. Criteria A
Surge ⁽⁹⁾	EN61000-4-5	±1KV Perf. Criteria A
Conducted Immunity	EN61000-4-6	10 Vr.m.s Perf. Criteria A
Weight		30.5g
Packing Quantity	Refer to App Notes for tube dimensions	9 pcs per Tube
Dimensions		50.8 x 25.4 x 10.2mm
MTBF ⁽²⁾	Belcore-TR-NWT-000332	3.163 x 10 ⁶ hours
	MIL-HDBK-217F	4.347 x 10 ⁵ hours

Notes :

1. The RP30-S_DFW series does not require any minimum load.
2. BELLCORE TR-NWT-000332. Case I: 50% Stress, Temperature at 40°C (Ground fixed and controlled environment)
MIL-HDBK-217F Notice2 @ TA= 25°C, Full load (Ground, Begign, controlled environment)
3. Simulated source impedance of 12μH. 12μH inductor in series with +Vin.
4. Typical value at nominal input voltage and no load of standard type
Maximum value at nominal input voltage and full load of standard type.
5. Typical value at nominal input voltage and full load.
6. Test by minimum Vin and constant resistor load.
7. The ON/OFF control function can be positive or negative logic. The pin voltage is referenced to negative input.
Positive logic ON/OFF is standard, no suffix (Ex. RP30-2405SFW)
Negative logic ON/OFF is marked with suffix-N (Ex. R320-2405SFW/N).
8. Heat sink is optional and P/N: 7G-0020-C . Powerline DC/DC Converters can be ordered with pre-mounted heatsinks including antivibration fixing clips (add suffix -HC). See Application Notes for heatsink details.
9. An external filter capacitor is required if the module has to meet EN61000-4-4,EN61000-4-5.
The filter capacitor RECOM suggest: 24Vin : Nippon chemi-con KY series, 330μF/50V, ESR 55mΩ.
48Vin : Nippon chemi-con KY series, 220μF/100V, ESR 48mΩ.
10. Meets class A with external components shown below. See application notes for Class B common mode filter suggestion

Package Style and Pinning (mm)

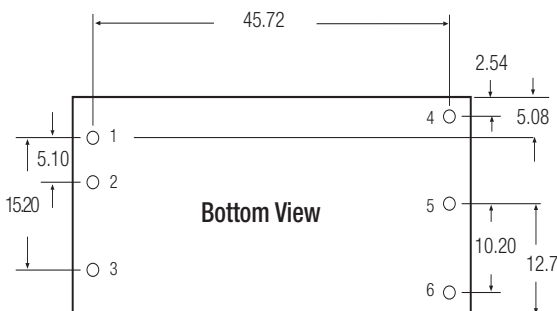
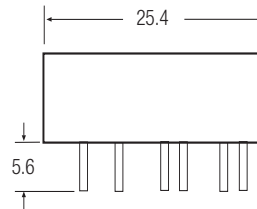
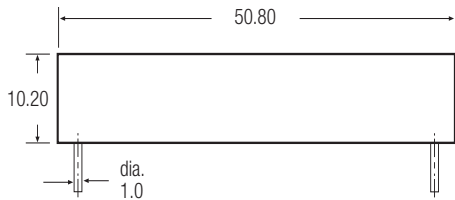

Pin Connections

Pin #	Single	Dual
1	+Vin	+Vin
2	-Vin	-Vin
3	CTRL	CTRL
4	+Vout	+Vout
5	-Vout	Com
6	Trim	-Vout

Pin Pitch Tolerance ±0.25 mm

EMC Filtering - For Class A filter suggestion, see Application Notes

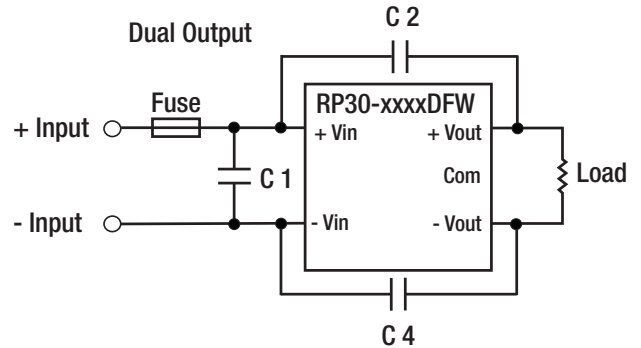
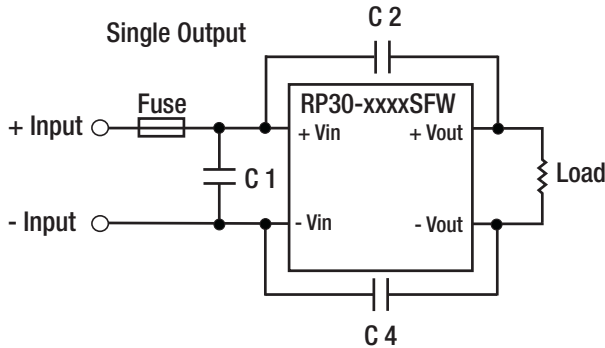

Single Output	C1	C2 & C3
RP30-24xxSFW	6.8 μ F/50V 1812 MLCC	1000pF/2KV 1808 MLCC
RP30-48xxSFW	2.2 μ F/100V 1812 MLCC	1000pF/2KV 1808 MLCC

Dual Output	C1	C2 & C4
RP30-24xxDFW	6.8 μ F/50V 1812 MLCC	1000pF/2KV 1808 MLCC
RP30-48xxDFW	2.2 μ F/100V 1812 MLCC	1000pF/2KV 1808 MLCC

Recommended EN55022 Class A Filter Circuit Layouts

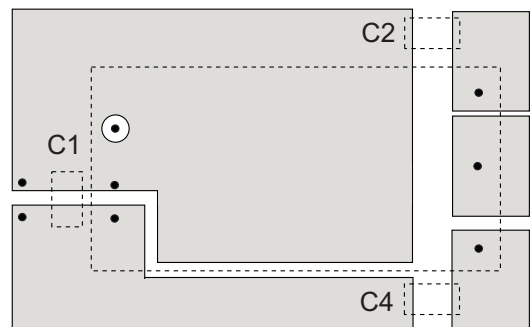
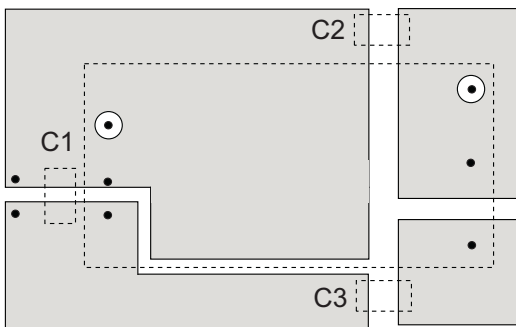

External Output Trimming

Output can be externally trimmed by using the method shown below. See Application Notes for details.

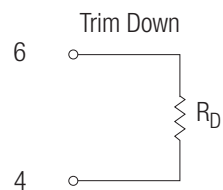
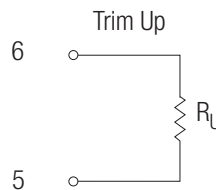

Features

- 2:1 Wide Input Voltage Range
- 40 Watts Output Power
- 1.6kVDC Isolation
- UL Certified
- Fixed Operating Frequency
- Six-Sided Continuous Shield
- Design Meet Safety Standard
- Standard 50.8 x50.8x10.2mm Package
- Efficiency to 90 %
- Available as Power Module (RPM40-G)

Description

The RP40-G series DC/DC converters are certified to UL 60950-1 and to cUL 60950-1. This makes them ideal for all telecom and industrial applications where approved safety standards are required.

The industry standard 2" x 2" package meets military standards for thermal shock and vibration tolerance.

Selection Guide Single and Dual Outputs

Part Number	Input Range VDC	Output Voltage VDC	Output Current mA	Input ⁽⁴⁾ Current mA	Efficiency ⁽⁶⁾ %	Capacitive ⁽⁶⁾ Load max.
RP40-123.3SG	9-18	3.3	8000	2750	84	21000µF
RP40-1205SG	9-18	5	8000	4065	86	13600µF
RP40-1212SG	9-18	12	3333	4065	86	2360µF
RP40-1215SG	9-18	15	2666	4015	87	1510µF
RP40-243.3SG	18-36	3.3	8000	1325	87	21000µF
RP40-2405SG	18-36	5	8000	1961	89	13600µF
RP40-2412SG	18-36	12	3333	2048	88	2360µF
RP40-2415SG	18-36	15	2666	1985	89	1510µF
RP40-483.3SG	36-75	3.3	8000	655	88	21000µF
RP40-4805SG	36-75	5	8000	969	90	13600µF
RP40-4812SG	36-75	12	3333	1000	89	2360µF
RP40-4815SG	36-75	15	2666	992	89	1510µF
RP40-1212DG	9-18	±12	±1800	4444	85	±1200µF
RP40-1215DG	9-18	±15	±1400	4321	85	±750µF
RP40-2412DG	18-36	±12	±1800	2169	87	±1200µF
RP40-2415DG	18-36	±15	±1400	2108	87	±750µF
RP40-4812DG	36-75	±12	±1800	1084	87	±1200µF
RP40-4815DG	36-75	±15	±1400	1054	87	±750µF
RP40-120512TG	9-18	5 / ±12	6000 / ±400	4024	86	6800µF/±330µF
RP40-120515TG	9-18	5 / ±15	6000 / ±300	3963	86	6800µF/±110µF
RP40-240512TG	18-36	5 / ±12	6000 / ±400	1989	87	6800µF/±330µF
RP40-240515TG	18-36	5 / ±15	6000 / ±300	1958	87	6800µF/±110µF
RP40-480512TG	36-75	5 / ±12	6000 / ±400	982	88	6800µF/±330µF
RP40-480515TG	36-75	5 / ±15	6000 / ±300	967	88	6800µF/±110µF

* no suffix for CTRL function with Positive Logic (1=ON, 0=OFF), this is standard

* add suffix **-HC** for premounted heatsink and clips

Ordering Examples

RP40-2405SG = 24V Input, 5V Output, Positive Logic CTRL pin.

RP20-4812DG-HC = 48V Input, ±12V Output, Positive Logic CTRL pin, Heatsink fitted

RP20-120512TG-HC = 24V Input, 5V and ±12V Outputs, Positive Logic CTRL pin, Heatsink fitted

POWERLINE

DC/DC-Converter

with 3 year Warranty

RECOM

40 Watt Single, Dual & Triple Output



UL-60950-1 Certified
E196683

RP40-G

Derating-Graph (Ambient Temperature)

RP40-4805SG

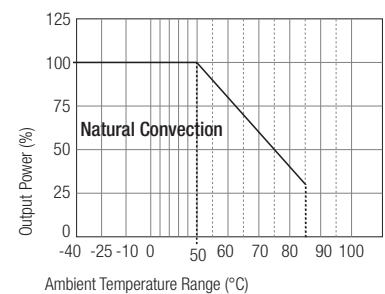

Derating graphs are valid only for the shown part numbers. If you need detailed derating information about a part-number not shown here please contact our technical support service at info@recom-development.at

Refer to Application Notes

Typical Characteristics

RP40-4805SG

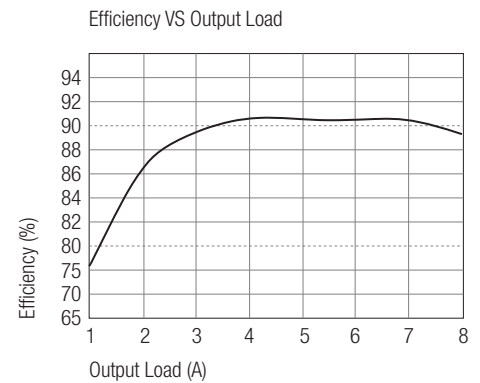
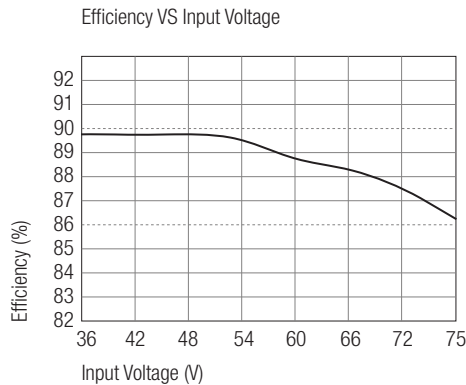

Specifications (typical at nominal input and 25°C unless otherwise noted)

Input Voltage Range	12V nominal input	9-18VDC	
	24V nominal input	18-36VDC	
	48V nominal input	36-75VDC	
Under Voltage Lockout	12V input	DC-DC ON	9VDC
		DC-DC OFF	8VDC
	24V input	DC-DC ON	17.8VDC
		DC-DC OFF	16VDC
	48V input	DC-DC ON	36VDC
		DC-DC OFF	34VDC
Input Filter ⁽¹³⁾		L-C Type	
Input Voltage Variation dv/dt	(Complies with ETS300 132 part 4.4)	5V/ms max	
Input Surge Voltage (100 ms max.)	12V Input	36VDC	
	24V Input	50VDC	
	48V Input	100VDC	
Input Reflected Ripple (nominal Vin and full load ⁽³⁾)		40mA _{p-p}	
Start Up Time (nominal Vin and constant resistor load)		25ms typ.	
Remote ON/OFF ⁽⁷⁾ (Positive logic)	DC-DC ON	Open or 3.5V < Vr < 12V	
	DC-DC OFF	Short or 0V < Vr < 1.2V	
Remote OFF input current	Nominal input	2.5mA	
Output Power		40W max.	
Output Voltage Accuracy (full Load and nominal Vin)	Single & Dual	±1%	
	Triple Main	±1%	
	Auxiliary	±5%	
Voltage Adjustability		±10%	
Minimum Load	Single and Dual Positive	0%	
	Dual and Triple	10% of full load	
Line Regulation (low line, high line at full load)	Single & Dual	±0.5%	
	Triple Main	±1%	
	Triple Auxiliary	±5%	
Load Regulation (10% to 100% full load see Note ^(9,10))	Single	±0.5%	
	Dual	±1%	
	Triple Main	±2%	
	Auxiliary	±5%	

continued on next page

Specifications (typical at nominal input and 25°C unless otherwise noted)

Cross Regulation ⁽¹¹⁾ (Asymmetrical 25% <> 100% load)	Triple Main	±1%
	Dual / Triple Auxiliary	±5%
Ripple and Noise (20MHz bandwidth, with 1µF MLCC on output) (Measured with a 1004pF/50V MLCC)	Single 3.3, 5V	50mVp-p
	Single 12, 15V	75mVp-p
	Dual 12V	120mVp-p
	Dual 15V	150mVp-p
	RP40-xxxxxTG ⁽¹²⁾	50 / 75mVp-p
Temperature Coefficient		±0.02%/°C max.
Transient Response (25% load step change)		300µs
Over Voltage Protection Zener diode clamp (only single)	3.3V	3.9V
	5V	6.2V
	12V	15V
	15V	18V
Over Load Protection (% of full load at nominal Vin)		150% max
Undervoltage Lockout		See Application Notes
Short Circuit Protection		Hiccup, automatic recovery
Efficiency		see „Selection Guide“ table
Isolation Voltage (rated for one minute)		1600VDC
Isolation Resistance		1 GΩ min.
Isolation Capacitance		1000pF max.
Operating Frequency ⁽¹⁴⁾		300kHz typ.
Approved to Safety Standards	Single, Triple	UL 1950, EN60950
	Dual	EN60950
Operating Temperature Range		-40°C to +85°C(with derating)
Maximum Case Temperature		100°C
Storage Temperature Range		-55°C to +125°C
Thermal Impedance ⁽⁸⁾	Natural convection	9.2°C/Watt
	Heat Sink with 20LFM	7.6°C/Watt
	Heat Sink with 500LFM	2.8°C/Watt
Thermal Shock		MIL-STD-810D
Vibration		10-55Hz, 10G, 30 Min. along X, Y and Z
Relative Humidity		5% to 95% RH
Case Material		Nickel plated copper
Base Material		Non-conductive black plastic FR4
Potting Material		Epoxy (UL94-V0)
Conducted Emissions ⁽¹⁶⁾	EN55022	Class A
Radiated Emissions	EN55022	Class A
ESD	EN61000-4-2	Perf. Criteria B
Radiated Immunity	EN61000-4-3	Perf. Criteria B
Fast Transient	EN61000-4-4	Perf. Criteria B
Surge	EN61000-4-5	Perf. Criteria B
Conducted Immunity	EN61000-4-6	Perf. Criteria B
Weight		60g
Packing Quantity	Refer to App Notes for tube dimensions	4 pcs per Tube
Dimensions		50.8 x 50.8 x 10.2mm
MTBF ⁽²⁾		1398 x 10 ³ hours

Notes :

1. Maximum output deviation is 10% inclusive of remote sense and trim. If remote sense is not being used, the +Vsense should be connected to its corresponding +OUTPUT and likewise the sense should be connected to its corresponding -OUTPUT
2. BELLCORE TR-NWT-000332. Case I: 50% Stress, Temperature at 40°C (Ground fixed and controlled environment).
3. Simulated source impedance of 12μH. 12μH inductor in series with +Vin.
4. Maximum value at nominal input voltage and full load of standard type.
5. Typical value at nominal input voltage and full load.
6. Test by minimum Vin and constant resistor load.
7. The ON/OFF control pin voltage is referenced to negative input.
8. Heat sink is optional and P/N: 7G-0026-C. Powerline DC/DC Converters can be ordered with pre-mounted heatsinks including antivibration fixing clips (add suffix -HC). See Application Notes for heatsink details.
9. The triple output required a minimum 10% loading on the output to maintain specified regulation. Operation under no-load condition will not damage these devices, however they may not meet all listed specification.
10. Load regulation for triple output: Main output(V1):10 to 100% with 10% to 100% balanced on auxiliaries.
Auxiliary outputs(V2 and V3):10% to 100% balanced on all outputs.
11. Cross regulation for triple output: Main output 100% load, auxiliary 100%, other auxiliary 25% to 100%.
Auxiliary outputs(V2 and V3):main output 100% load, auxiliary 100%, other auxiliary 25% to 100% or main output 25%, auxiliary 25%, other auxiliary 25% to 100%.
12. The models of RP40-XX3.305DG are specified with a 1uF ceramic output capacitors.
13. An external filter capacitor is required for normal operation. The capacitor should be capable of handling 1A ripple current for 48V/24V models.
RECOM suggest: Nippon chemi-con KY series, 220μF/100V, ESR 90m Ω.
14. Operating frequency for dual output: master (5Vo) 300KHz slave (3.3Vo) 500KHz.
15. Any condition of dual output (3.3V/5V) rated lout current, not to exceed 8A of total output currents. The product safety approval pending.
16. See application notes for Class B common mode filter suggestion

Package Style and Pinning (mm)

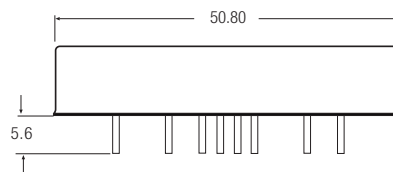
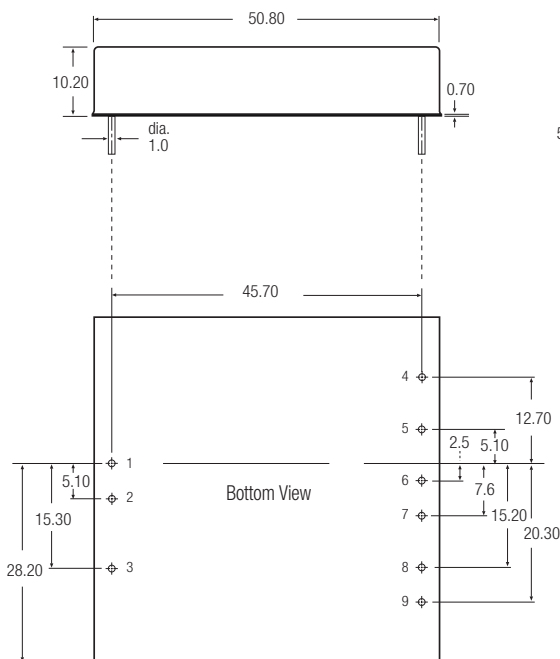

Pin Connections

Pin #	Single	Dual	Triple
1	+Vin	+Vin	+Vin
2	-Vin	-Vin	-Vin
3	CTRL	CTRL	CTRL
4	NC	No Pin	+Aux
5	-Sense (Note1)	+Vout	Com
6	+Sense (Note1)	Com	-Aux
7	+Vout	Com	+Vout
8	-Vout	-Vout	-Vout(Com)
9	Trim	Trim	NC

NC = No Connection

Pin Pitch Tolerance ±0.35 mm

External Output Trimming

Output can be externally trimmed by using the method shown below. () for dual output trim.
See Application Notes for more details

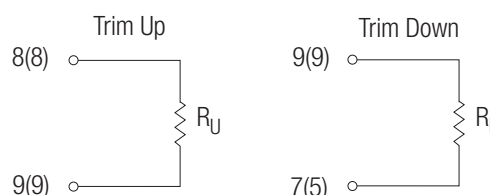

Features

Regulated Converters

- 4:1 Wide Input Voltage Range
- 40 Watts Regulated Output Power
- 1.6kVDC Isolation
- Over Current and Over Voltage Protection
- Six-Sided Shield
- No Derating to 55°C
- Standard 2" x 2" Package and Pinning
- Efficiency to 86 %
- Available as Power Module (RPM40-GW)

Description

The RP40-GW series wide input range DC/DC converters are certified to UL 60950-1 and to cUL 60950-1. This makes them ideal for all telecom and industrial applications where approved safety standards are required. The industry standard 2" x 2" package meets military standards for thermal shock and vibration tolerance.

Selection Guide 24V and 48V Wide Input Types

Part Number	Input Range VDC	Output Voltage VDC	Output Current mA	Input Current mA ^(4,5)	Efficiency % ⁽⁶⁾	Capacitive Load max. ⁽⁷⁾
RP40-243.3SGW	9-36	3.3	10000	80/1677	86	25750µF
RP40-2405SGW	9-36	5	8000	100/2008	87	13600µF
RP40-2412SGW	9-36	12	3333	50/2008	87	2360µF
RP40-2415SGW	9-36	15	2666	50/2008	87	1510µF
RP40-483.3SGW	18-75	3.3	10000	60/838	86	25750µF
RP40-4805SGW	18-75	5	8000	65/992	88	13600µF
RP40-4812SGW	18-75	12	3333	30/1004	87	2360µF
RP40-4815SGW	18-75	15	2666	30/1004	87	1510µF
RP40-2412DGW	9-36	±12	±1667	60/2032	86	±1200µF
RP40-2415DGW	9-36	±15	±1333	70/2032	86	±750µF
RP40-4812DGW	18-75	±12	±1667	30/1016	86	±1200µF
RP40-4815DGW	18-75	±15	±1333	30/1016	86	±750µF

* no suffix for CTRL function with Positive Logic (1=ON, 0=OFF), this is standard

* add /N for CTRL function with Negative Logic (0=ON, 1=OFF)

* add suffix -HC for premounted heatsink and clips

Ordering Examples

RP40-2405SGW = 24V 4:1 Input, 5V Output, Positive Logic CTRL pin.

RP20-4812DGW/N-HC = 48V 4:1 Input, ±12V Output, Negative Logic CTRL pin, Heatsink fitted

POWERLINE

DC/DC-Converter

with 3 year Warranty

RECOM

40 Watt

2" x 2"

Single & Dual

Output



UL-60950-1 Certified
E196683

RP40-GW

Derating-Graph (Ambient Temperature)

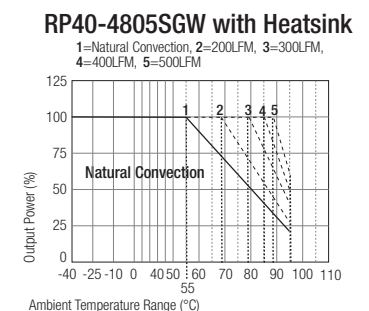
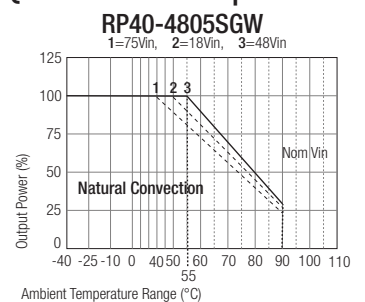

Refer to Application Notes

Derating graphs are valid only for the shown part numbers. If you need detailed derating-information about a part-number not shown here please contact our technical support service at info@recom-development.at

Efficiency Graphs (25°C Ambient Temperature)

RP40-4805SGW

Efficiency VS Output Load

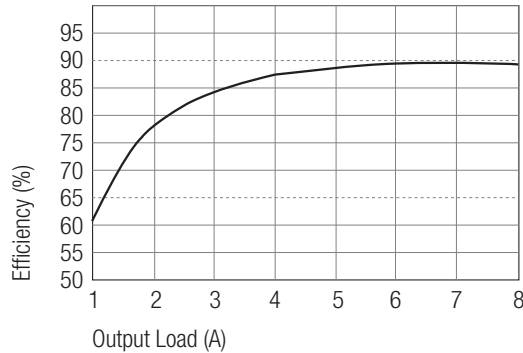

RP40-4805SGW

Efficiency VS Input Voltage

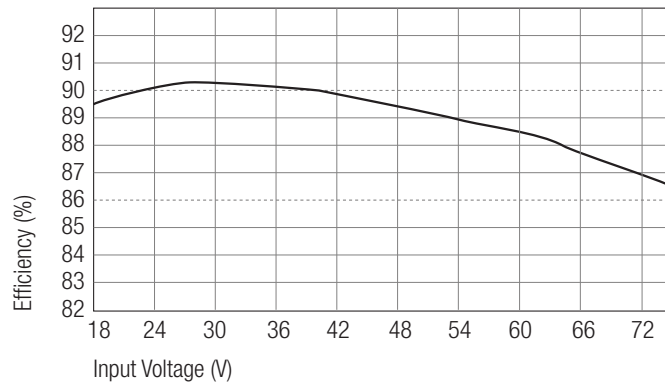

Specifications (typical at nominal input and 25°C unless otherwise noted)

Input Voltage Range	24V nominal input	9-36VDC	
	48V nominal input	18-75VDC	
Undervoltage Protection	24V Input	DC-DC ON = 9VDC, DC-DC OFF = 8VDC	
	48V Input	DC-DC ON = 18VDC, DC-DC OFF = 16VDC	
Input Filter		Pi Type	
Input Voltage Variation dv/dt	(Complies with ETS300 132 part 4.4)	5V/ms max	
Input Surge Voltage (100 ms max.)	24V Input	50VDC	
	48V Input	100VDC	
Input Reflected Ripple (nominal Vin and full load) ⁽³⁾		20mA _{p-p}	
Start Up Time (nominal Vin and constant resistive load)		20ms typ.	
Remote ON/OFF ⁽⁷⁾	(Positiv logic)	DC-DC ON	Open or 3V < Vr < 12V
		DC-DC OFF	Short or 0V < Vr < 1.2V
	(Negativ logic)	DC-DC ON	Short or 0V < Vr < 1.2V
		DC-DC OFF	Open or 3V < Vr < 12V
Remote OFF state input current	Nominal input	24Vin:	10mA
		48Vin:	5mA
Output Power		40W max.	
Output Voltage Accuracy (full Load and nominal Vin)		±1%	

continued on next page

Specifications (typical at nominal input and 25°C unless otherwise noted)

Voltage Adjustability ⁽¹⁾		±10%
Load Regulation (min. load to full load) ^(9,10)	Single	±0.5%
	Dual	±1%
Line Regulation (low line, high line at full load)		±0.2%
Cross Regulation ⁽¹⁰⁾	Dual	±5%
Temperature Coefficient		±0.02%/°C max.
Ripple and Noise (20MHz bandwidth, with 1µF MLCC on output)	Single 3.3, 5V	50mVp-p
	Single 12, 15V	75mVp-p
	Dual 12V	120mVp-p
	Dual 15V	150mVp-p
Transient Response (25% load step change)		250µs
Over Voltage Protection	3.3 Vout	3.9V
Zener diode clamp (only single)	5 Vout	6.2V
	12 Vout / ±12 Vout	15V / ±15V
	15 Vout / ±15 Vout	18V / ±18V
Over Load Protection (% of full load at nominal Vin)		150% max.
Undervoltage Lockout		See Application Notes
Short Circuit Protection		Hiccup, automatic recovery
Efficiency		see „Selection Guide“ table
Isolation Voltage (rated for one minute)		1600VDC
Isolation Resistance		1 GΩ min.
Isolation Capacitance		2500pF max.
Operating Frequency		300kHz typ.
Operating Temperature Range		-40°C to +55°C(without derating)
		+55°C to +95°C(with derating)
Maximum Case Temperature		105°C
Storage Temperature Range		-55°C to +125°C
Over Temperature Protection		110°C typ.
Thermal Impedance ⁽⁸⁾	Without Heat-Sink	9.2°C/Watt
	With Heat-Sink	7.6°C/Watt
Thermal Shock		MIL-STD-810D
Vibration		10-55Hz, 10G, 30 Min. along X, Y and Z
Relative Humidity		5% to 95% RH
Case Material		Nickel plated copper
Base Material		RF4 PCB
Potting Material		Epoxy (UL94-V0)
Conducted Emissions ^(12,13)	EN55022	Class A
Radiated Emissions	EN55022	Class A
ESD	EN61000-4-2	Perf. Criteria A
Radiated Immunity	EN61000-4-3	Perf. Criteria A
Fast Transient	EN61000-4-4	Perf. Criteria B
Surge	EN61000-4-5	Perf. Criteria B
Conducted Immunity	EN61000-4-6	Perf. Criteria A
Weight		60g
Packing Quantity	Refer to App Notes for tube dimensions	4 pcs per Tube
Dimensions		50.8 x 50.8 x 10.2mm
MTBF ⁽²⁾	Bellcore TR-NWT-000332	1105 x 10 ³ hours
	MIL-HDBK-217F	151 x 10 ³ hours

Notes :

1. For the single output: Maximum output deviation is 10% inclusive of remote sense and trim. If remote sense is not being used, the +sense should be connected to its corresponding +OUTPUT and likewise the -sense should be connected to its corresponding -OUTPUT.
2. BELLCORE TR-NWT-000332. Case I: 50% Stress, Temperature at 40°C MIL-HDBK-217F Notice 2 @ Ta=25°C, full load (GroundBenign, controlled environment).
3. Simulated source impedance of 12μH. 12μH inductor in series with +Vin.
4. Maximum value at nominal input voltage and no load.
5. Typical value at nominal input voltage and full load.
6. Test by minimum Vin and constant resistive load.
7. The ON/OFF control function. There are positive logic (standard) and negative logic (option). The pin voltage is referenced to Vin- input
To order negative logic ON/OFF control add the suffix-N (Ex: RP40-4805SGW-N).
8. Heat sink is optional and P/N: 7G-0026-C. Powerline DC/DC Converters can be ordered with pre-mounted heatsinks including antivibration fixing clips (add suffix -HC). See Application Notes for heatsink details.
9. The dual output required a minimum loading on the output to maintain specified regulation. Operation under no-load condition will not damage these devices, however they may not meet all listed specification.
10. Load regulation for dual output : Min load to 100% load balanced on all outputs.
11. Cross regulation for dual output : asymmetrical load 25% <> 100% FL.
- 12..The RP40-GW series required external filter to meets EN55022 class A.
13. See application notes for Class B common mode filter suggestion

Package Style and Pinning (mm)

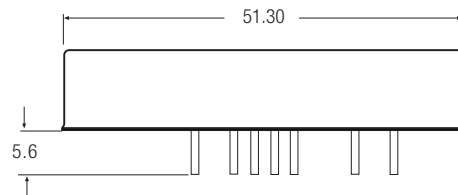
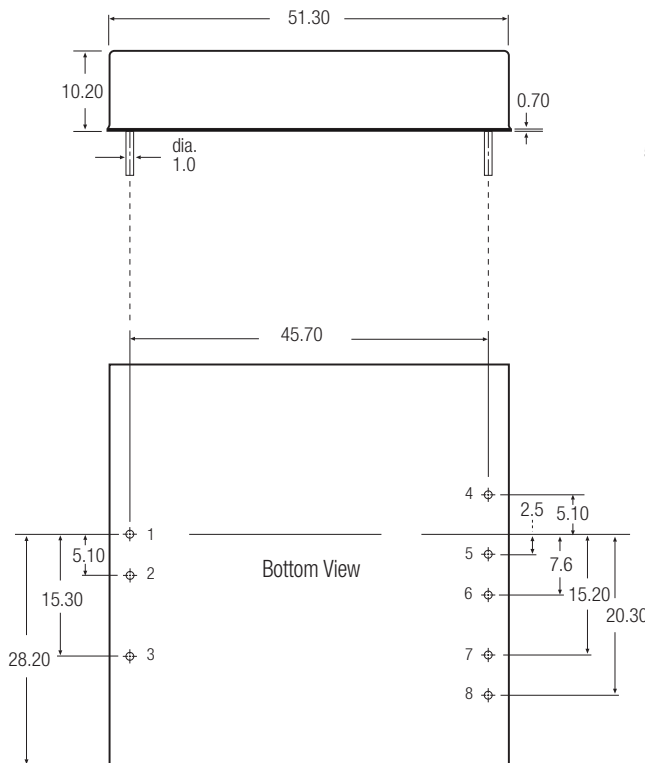

Pin Connections

Pin #	Single	Dual
1	+Vin	+Vin
2	-Vin	-Vin
3	CTRL	CTRL
4	-SENSE (Note 1)	+Vout
5	+SENSE (Note 1)	Com
6	+Vout	Com
7	-Vout	-Vout
8	TRIM	TRIM

Pin Pitch Tolerance ±0.25 mm

External Output Trimming

Output can be externally trimmed by using the method shown below. () for dual output tri.
See Application Notes for more details.

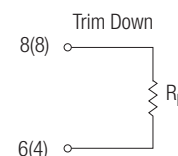
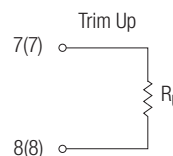

Features

Regulated Converters

- 60 Watts Regulated Output Power
- 2:1 Wide Input Voltage Range
- 1.6kVDC Isolation (Basic Insulation)
- Overload and Over Temperature Protection
- Six-Sided Shield
- No Derating to 40°C
- Standard 2" x 2" Package and Pinning
- Efficiency to 90 %
- Available as Power Module (RPM60-G)

Description

The RP60-G series DC/DC converters deliver 60W of power in an industry standard 2" x 2" package, which also meets military standards for thermal shock and vibration tolerance.

Sense pins allow the output voltage at the point of load to be tightly regulated and automatically compensate for any voltage drops that may occur across any connections.

Selection Guide 24V and 48V Wide Input Types

Part Number	Input Range VDC	Output Voltage VDC	Output Current mA	Input Current (4,5) mA	Efficiency (6) %	Capacitive (6) Load max. μ F
RP60-243.3SG	18-36	3.3	14000	100/2264	89	36000 μ F
RP60-2405SG	18-36	5	12000	130/2941	90	20400 μ F
RP60-2412SG	18-36	12	5000	150/2907	90	3550 μ F
RP60-2415SG	18-36	15	4000	150/2907	90	2300 μ F
RP60-483.3SG	36-75	3.3	14000	80/1132	89	36000 μ F
RP60-4805SG	36-75	5	12000	90/1453	90	20400 μ F
RP60-4812SG	36-75	12	5000	100/1453	90	3550 μ F
RP60-4815SG	36-75	15	4000	100/1453	90	2300 μ F

* no suffix for CTRL function with Positive Logic (1=ON, 0=OFF), this is standard

* add /N for CTRL function with Negative Logic (0=ON, 1=OFF)

* add suffix **-HC** for premounted heatsink and clips

Ordering Examples

RP60-2405SG = 24V Input, 5V Output, Positive Logic CTRL pin.

RP20-4812SG/N-HC = 48V Input, 12V Output, Negative Logic CTRL pin, Heatsink fitted

POWERLINE

DC/DC-Converter

with 3 year Warranty

RECOM

60 Watt

2" x 2"

Single Output

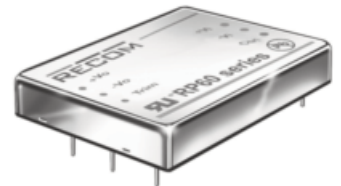

UL-60950-1 Certified
E196683

RP60-G

Derating-Graph (Ambient Temperature)

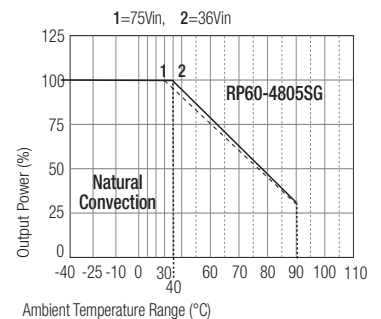

Derating graphs are valid only for the shown part numbers. If you need detailed derating information about a part-number not shown here please contact our technical support service at info@recom-development.at

Refer to Application Notes

Derating Graph (Ambient Temperature)

RP60-4805SG

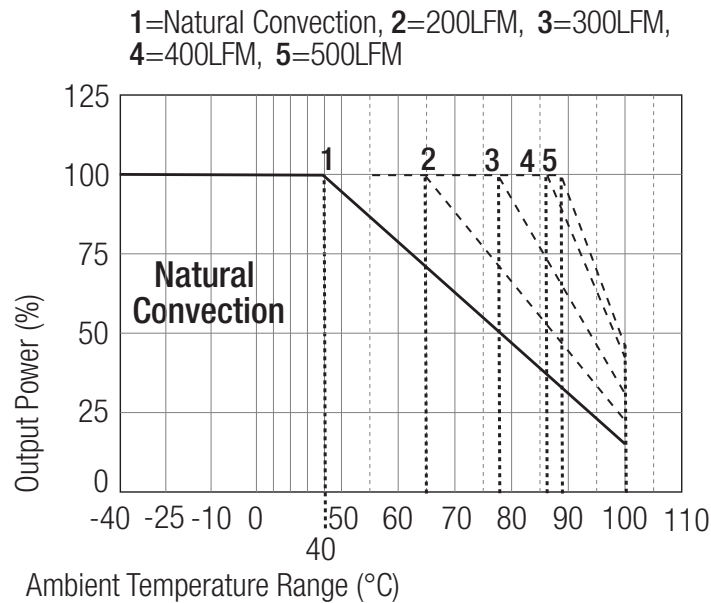

Specifications (typical at nominal input and 25°C unless otherwise noted)

Input Voltage Range	24V nominal input	18-36VDC	
	48V nominal input	36-75VDC	
Undervoltage Protection	24V Input	DC-DC ON = 17VDC, DC-DC OFF = 15VDC	
	48V Input	DC-DC ON = 34VDC, DC-DC OFF = 32VDC	
Input Filter		Pi Type	
Input Voltage Variation dv/dt	(Complies with ETS300 132 part 4.4)	5V/ms max	
Input Surge Voltage (100 ms max.)	24V Input	50VDC	
	48V Input	100VDC	
Input Reflected Ripple (nominal Vin and full load) ⁽³⁾		20mA _{p-p}	
Start Up Time (nominal Vin and constant resistor load)		20ms max.	
Remote ON/OFF ⁽⁷⁾	Positive logic - Standard	DC-DC ON	Open or 3V < Vr < 12V
		DC-DC OFF	Short or 0V < Vr < 1.2V
	Negative logic - /N Option	DC-DC ON	Short or 0V < Vr < 1.2V
		DC-DC OFF	Open or 3V < Vr < 12V
Remote Pin Drive Current	Nominal Vin	-0.5 -1.0mA	
Remote OFF input current	Nominal Vin	4mA	
Output Power		60W max.	
Output Voltage Accuracy (full Load and nominal Vin)		±1%	
Voltage Adjustability ⁽¹⁾		±10%	
Line Regulation	LL to HL at Full Load	±0.2%	
Load Regulation ⁽³⁾	0% to 100% Load	±0.5%	
Temperature Coefficient		±0.02%/°C max.	

continued on next page

Specifications (typical at nominal input and 25°C unless otherwise noted)

Ripple and Noise (20MHz bandwidth, with 1µF MLCC on output)	3.3,5V 12,15V	75mVp-p 100mVp-p
Transient Response (25% load step change)		250µs
Over Voltage Protection	3.3 Vout	3.7-5.4V
Zener diode clamp (only single)	5 Vout 12 Vout 15 Vout	5.6-7.0V 13.7-17.5V 16.8-20.5V
Over Load Protection (% of full load at nominal Vin)		150% max.
Undervoltage Lockout		See Application Notes
Short Circuit Protection		Hiccup, automatic recovery
Efficiency		see „Selection Guide“ table
Isolation Voltage (rated for one minute)		1600VDC
Isolation Resistance		1 GΩ min.
Isolation Capacitance		1500pF max.
Operating Frequency		300kHz typ.
Designed to meet Safety Standards		IEC60950-1, UL60950-1, EN60950-1
Operating Temperature Range		-40°C to +40°C(without derating) -40°C to +100°C(with derating)
Maximum Case Temperature		110°C
Storage Temperature Range		-55°C to +125°C
Over Temperature Protection		120°C typ.
Thermal Impedance ⁽¹⁾	Without Heat-Sink With Heat-Sink	10.5°C/Watt 8.4°C/Watt
Thermal Shock		MIL-STD-810D
Vibration		10-55Hz, 10G, 30 Min. along X, Y and Z
Relative Humidity		5% to 95% RH
Case Material		Nickel plated copper
Base Material		Non-conductive black plastic FR4
Potting Material		Epoxy (UL94-V0)
Conducted Emissions ^(9,10)	EN55022	Class A
Radiated Emissions	EN55022	Class A
ESD	EN61000-4-2	Perf. Criteria B
Radiated Immunity	EN61000-4-3	Perf. Criteria A
Fast Transient	EN61000-4-4	Perf. Criteria B
Surge	EN61000-4-5	Perf. Criteria B
Conducted Immunity	EN61000-4-6	Perf. Criteria A
Weight		60g
Packing Quantity	Refer to App Notes for tube dimensions	4 pcs per Tube
Dimensions		50.8 x 50.8 x 10.2mm
MTBF ⁽²⁾	Bellcore TR-NWT-00332 MIL-STD-217F	1093 x 10 ³ hours 1096 x 10 ³ hours

RP60-G

Notes :

1. Maximum output deviation is 10% inclusive of remote sense and trim. If remote sense is not being used, the +sense should be connected to its corresponding +OUTPUT and likewise the -sense should be connected to its corresponding -OUTPUT.
2. BELLCORE TR-NWT-000332. Case I: 50% Stress, Temperature at 40°C (Ground fixed and controlled environment).
3. No minimum loading on the output is required to maintain specified regulation. Operation under no-load condition will not damage these devices
4. Maximum value at nominal input voltage and no load.
5. Typical value at nominal input voltage and full load.
6. Test by minimum V_{in} and constant resistive load.
7. The ON/OFF control pin voltage is referenced to the negative input (-Vin).
To order negative logic ON/OFF control add the suffix-N (Example: RP60-4805SG-N).
8. Heat sink is optional and P/N: 7G-0026-C. Powerline DC/DC Converters can be ordered with pre-mounted heatsinks including antivibration fixing clips (add suffix -HC). See Application Notes for heatsink details.
9. The RP60-SG series meets EN55022 Class A with an external capacitor across the input pins (24Vin:6.8 μ F/50V MLCC, 48Vin:2x2,2 μ F/100V MLCC)
10. See application notes for Class B common mode filter suggestion.
11. Vertical orientation and natural convection.

Package Style and Pinning (mm)

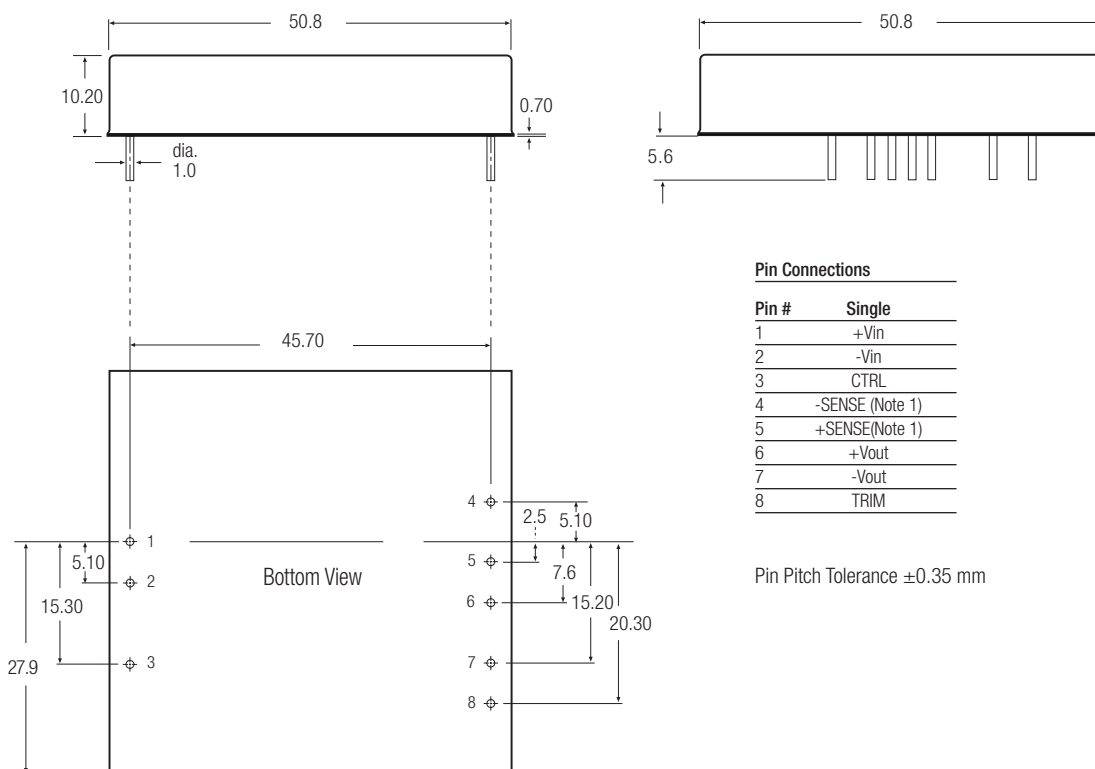

Pin Connections

Pin #	Single
1	+Vin
2	-Vin
3	CTRL
4	-SENSE (Note 1)
5	+SENSE (Note 1)
6	+Vout
7	-Vout
8	TRIM

Pin Pitch Tolerance ± 0.35 mm

External Output Trimming

Output can be externally trimmed by using the method shown below.

See Application Notes for more details.

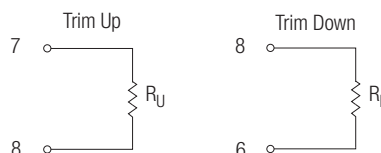

Features

- DC/DC Power Module
- 15W to 40W with 4:1 inputs, 60W with 2:1
- Screw Terminal Connections
- Class B EMC Filter built-in
- Input Fuse
- Reverse Polarity Protected
- Inrush Current Limiting (Soft Start)
- Output Trim Potentiometer
- Output LED Indicator
- DIN Rail Mounting or Panel Mount Options

Description

The Recom Power Module takes a standard 15W-60W converter and mounts it on a PCB with screw terminals, an EMC filter, input protection circuitry and a built-in heatsink to offer a complete power module that can be mounted on a bulkhead or on a standard DIN rail. The Power Module is primarily designed for transport applications such as a GPS vehicle tracking power supply or a radio communications power supply, but will also find many uses in industrial, communications or battery-powered applications.

How to use this datasheet:

1. Select the converter that suits your application from the converter series list below
 2. Decide on DIN Mount (RPMD) or bulkhead (RPM) version
- Ordering example: 40W, 18-75 VDC in, single 12V out, DIN Mount = RPMD40-4812SGW

Selection Guide Single and Dual Outputs - Panel Mount Version

Power Module Part Number (Bulkhead Version)	Input Range VDC	Output Power Watts	Internal Fuse (Replaceable)	Converter Series
RPM15-24xxS_DFW**	9.5-36	15	T4A	RP15-24xxS_DFW
RPM15-48xxS_DFW**	18-75	15	T4A	RP15-48xxS_DFW
RPM20-24xxS_DFW**	9.5-36	20	T4A	RP20-24xxS_DFW
RPM20-48xxS_DFW**	18-75	20	T4A	RP20-48xxS_DFW
RPM30-24xxS_DEW**	10-40	30	T6A	RP30-24xxS_DEW
RPM30-48xxS_DEW**	18-75	30	T4A	RP30-48xxS_DGW
RPM40-48xxS_DGW**	18-75	40	T4A	RP40-48xxS_DGW
RPMD60-24xxSG**	18-36	60	T8A	RP60-24xxSG
RPMD60-48xxSG**	36-75	60	T4A	RP60-48xxSG

** add /P or /N for Positive or Negative CTRL logic

Selection Guide Single and Dual Outputs - DIN Rail Version

Power Module Part Number (DIN rail Version)	Input Range VDC	Output Power Watts	Internal Fuse (Replaceable)	Converter Series
RPMD15-24xxS_DFW**	9.5-36	15	T4A	RP15-24xxS_DFW
RPMD15-48xxS_DFW**	18-75	15	T4A	RP15-48xxS_DFW
RPMD20-24xxS_DFW**	9.5-36	20	T4A	RP20-24xxS_DFW
RPMD20-48xxS_DFW**	18-75	20	T4A	RP20-48xxS_DFW
RPMD30-24xxS_DEW**	10-40	30	T6A	RP30-24xxS_DEW
RPMD30-48xxS_DEW**	18-75	30	T4A	RP30-48xxS_DEW
RPMD40-24xxS_DGW**	9.5-36	40	T4A	RP40-24xxS_DGW
RPMD40-48xxS_DGW**	18-75	40	T4A	RP40-48xxS_DGW
RPMD60-24xxSG**	18-36	60	T8A	RP60-24xxSG
RPMD60-48xxSG**	36-75	60	T4A	RP60-48xxSG

** add /P or /N for Positive or Negative CTRL logic

xx = Output Voltage Options Single Outputs: 3.3S = 3.3V 05S = 5V 12S = 12V 15S = 15V
 Dual Outputs: 12D = ±12V 15D = ±15V

Refer to converter series datasheets for detailed information.

POWERLINE

DC/DC-Converter
 Power Module
 with 3 year Warranty

RECOM

15-60 Watt Single & Dual Outputs



**EN-60950-1 Certified
 CE Marked**

Power Modules

Derating-Graph (Ambient Temperature)

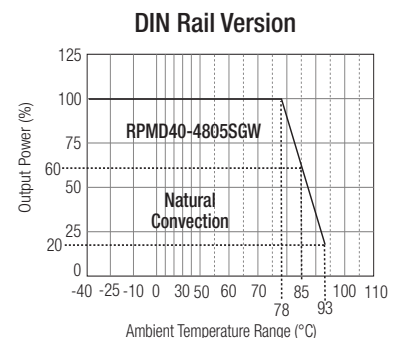

Derating graphs are valid only for the shown part numbers. If you need detailed derating information about a part-number not shown here please contact our technical support service at info@recom-development.at

Refer to Application Notes

Selection Guide Triple Outputs - Panel Mount Version

Power Module Part Number (Bulkhead Version)	Input Range VDC	Output Power Watts	Internal Fuse (Replaceable)	Converter Series
RPM40-120512TG**	9.5-18	40	T4A	RP40-120512TG
RPM40-120515TG**	9.5-18	40	T4A	RP40-120515TG
RPM40-240512TG**	18-36	40	T4A	RP40-240512TG
RPM40-240515TG**	18-36	40	T4A	RP40-240515TG
RPM40-480512TG**	36-75	40	T4A	RP40-480512TG
RPM40-480515TG**	36-75	40	T4A	RP40-480515TG

Selection Guide Triple Outputs - DIN Rail Version

Power Module Part Number (DIN rail Version)	Input Range VDC	Output Power Watts	Internal Fuse (Replaceable)	Converter Series
RPMD40-120512TG**	9.5-18	40	T4A	RP40-120512TG
RPMD40-120515TG**	9.5-18	40	T4A	RP40-120515TG
RPMD40-240512TG**	18-36	40	T4A	RP40-240512TG
RPMD40-240515TG**	18-36	40	T4A	RP40-240515TG
RPMD40-480512TG**	36-75	40	T4A	RP40-480512TG
RPMD40-480515TG**	36-75	40	T4A	RP40-480515TG

Specifications (typical at nominal input and 25°C unless otherwise noted)

Specifications are as in individual converter datasheets with the following exceptions:

Bulkhead Version

Input Voltage Range		see selection guide
Inrush current	Nominal Vin and Full Load	soft start
Startup time	Power up: Nominal Vin and Full Load	100ms typ.
	CTRL pin: Nominal Vin and Full Load	20ms typ.
Thermal impedance		8.5°C/W
Conducted Emissions	EN55022	Class B
Radiated Emissions	EN55022	Class B
ESD	EN61000-4-2	Perf. Criteria A
Radiated Immunity	EN61000-4-3	Perf. Criteria A
Fast Transient	EN61000-4-4	Perf. Criteria A
Surge	EN61000-4-5	Perf. Criteria A
Conducted Immunity	EN61000-4-6	Perf. Criteria A
Chassis Material		Aluminium
Connectors		Screw Terminal
Weight		134g
Packing Quantity		1 pc.
Dimensions		101.6 x 57.15 x 19.0mm
Certifications	LVD20110124	EN-60950-1:2006 + A11:2009 +A1:2010

DIN-Rail Version

Input Voltage Range		see selection guide
Inrush current	Nominal Vin and Full Load	<15A
Startup time	Power up: Nominal Vin and Full Load	100ms typ.
	CTRL pin: Nominal Vin and Full Load	20ms typ.
Thermal impedance		4.2°C/W
Conducted Emissions	EN55022	Class B
Radiated Emissions	EN55022	Class B
ESD	EN61000-4-2	Perf. Criteria A
Radiated Immunity	EN61000-4-3	Perf. Criteria A
Fast Transient	EN61000-4-4	Perf. Criteria A
Surge	EN61000-4-5	Perf. Criteria A
Conducted Immunity	EN61000-4-6	Perf. Criteria A
Chassis Material		Aluminium
Connectors		Screw Terminal
Weight		182g
Packing Quantity		30 pcs.
Dimensions		125.0 x 57.6 x 24.5mm
Certifications	LVD20110124	EN-60950-1:2006 + A11:2009 +A1:2010

Package Style and Connections

Panel Mount Version

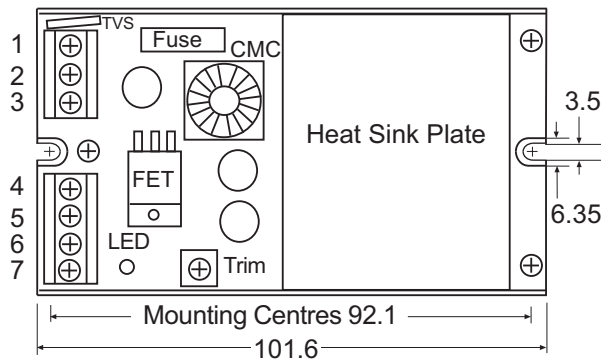
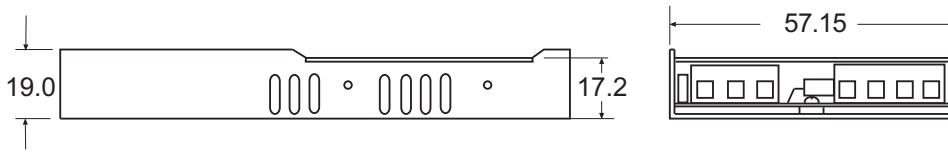

Screw Terminal Connections

Terminal	Single	Dual
1	+Vin	+Vin
2	-Vin	-Vin
3	CTRL	CTRL
4	NC	NC
5	-Vout	-Vout
6	+Vout	Com
7	NC	+Vout

Tolerance ± 0.25 mm

DIN Rail Version

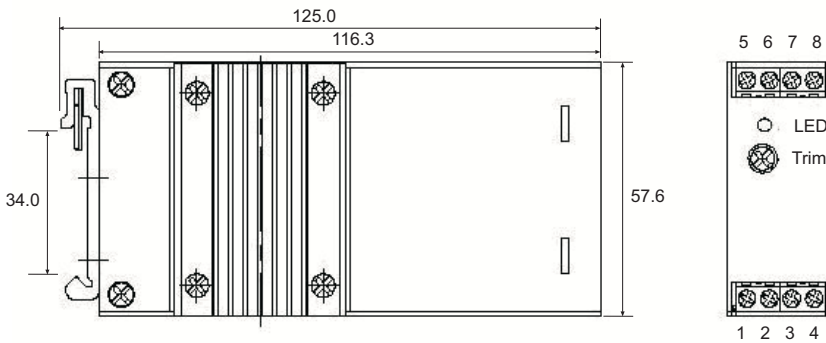

Screw Terminal Connections

Terminal	Single	Dual	Triple
1	CTRL	CTRL	CTRL
2	-Vin	-Vin	-Vin
3	-Vin	-Vin	-Vin
4	+Vin	+Vin	+Vin
5	NC	NC	+Auxiliary
6	-Vout	-Vout	Com
7	+Vout	Com	-Auxiliary
8	NC	+Vout	+Vout

Tolerance ± 0.5 mm

POWERLINE PLUS - CONTENTS

The POWERLINE PLUS RAILWAY uses ICE Technology. A combination of techniques to minimise internal heat dissipation and maximise the heat transfer to ambient to create a new converter series which offers high end performance at a price which is significantly lower than conventional specialist converters.

RECOM - Green high-efficiency power solutions. SAVE ENERGY. NOW.



Introduction

The RPR series DC/DC converters are designed for railway rolling stock applications.

Besides covering all the input voltages from 24VDC up to 110VDC, the converters have a very wide operating temperature range of -45°C to +85°C. Although the case size is very compact, the converter contains a built-in Class A EMI filter, so few external components are required.

The RPR series is available in two case styles: a low profile flat top case, a ribbed case with a built-in heatsink and the baseplate case for high vibration or bulkhead-mounting applications.

They are EN 50155 and EN 50121-3-2 compliant.

Regulated DC/DC Converters

Series (**)	Isolation (kVDC)	Power (Watts)	Input Voltages (VDC)	Output Voltages (VDC)	Case Options	Outputs	Page No.
RPR20	1.6	20	12-36, 25-75, 40-160	3.3, 5, 12, 15, 24 ±12, ±15, ±24	Baseplate	Single and Dual	RPR-1
RPR30	1.6	30	12-36, 25-75, 40-160	3.3, 5, 12, 15, 24 ±12, ±15, ±24	Baseplate	Single and Dual	RPR-11
RPR40	1.6	40	12-36, 25-75, 40-160	3.3, 5, 12, 15, 24 ±12, ±15, ±24	Baseplate	Single and Dual	RPR-22
RPR50	1.6	50	12-36, 25-75, 40-160	3.3, 5, 12, 15, 24 ±12, ±15, ±24	Baseplate	Single	RPR-33

Features

ICE Technology*

- T2 Temperature Range without Derating
- 120°C Maximum Case Temperature
- -45°C Minimum Operating Temperature
- EN 50155 Certified
- EN 50121-3-2 Certified
- CE Marked
- 24, 48 and 110VDC Input Ranges
- Six Sided Shielded Enclosure
- Baseplate Case Style
- Efficiency to >89%
- Low Quiescent Current

Description

The RPR20 series DC/DC converters are designed for railway rolling stock applications. Besides covering all the input voltages from 24VDC up to 110VDC, the converters have a very wide case temperature range of -45°C to +120°C. The RPR20 has a baseplate case for high vibration or bulkhead mounting applications. It is EN 50155 and EN 50121-3-2 certified.

Selection Guide 24V, 48V and 110V Input Types

Part Number	Nominal Input VDC	Nom. Input Range VDC	Lockout Voltage VDC	Output Voltage VDC	Output Current mA
RPR20-243.3S-B	24	12-36	8	3.3	6000
RPR20-2405S-B	24	12-36	8	5	4000
RPR20-2412S-B	24	12-36	8	12	1666
RPR20-2415S-B	24	12-36	8	15	1333
RPR20-2424S-B	24	12-36	8	24	830
RPR20-483.3S-B	48	25-75	17	3.3	6000
RPR20-4805S-B	48	25-75	17	5	4000
RPR20-4812S-B	48	25-75	17	12	1666
RPR20-4815S-B	48	25-75	17	15	1333
RPR20-4824S-B	48	25-75	17	24	830
RPR20-1103.3S-B	110	40-160	36	3.3	6000
RPR20-11005S-B	110	40-160	36	5	4000
RPR20-11012S-B	110	40-160	36	12	1666
RPR20-11015S-B	110	40-160	36	15	1333
RPR20-11024S-B	110	40-160	36	24	830
RPR20-2412D-B	24	12-36	8	±12	±833
RPR20-2415D-B	24	12-36	8	±15	±666
RPR20-2424D-B	24	12-36	8	±24	±416
RPR20-4812D-B	48	25-75	17	±12	±833
RPR20-4815D-B	48	25-75	17	±15	±666
RPR20-4824D-B	48	25-75	17	±24	±416
RPR20-11012D-B	110	40-160	36	±12	±833
RPR20-11015D-B	110	40-160	36	±15	±666
RPR20-11024D-B	110	40-160	36	±24	±416

For other CTRL logic or case style options please contact RECOM for availability.

POWERLINE+

Railway-Converter

with 5 year Warranty



20 Watt

Single &

Dual Output



EN-50155 Certified

EN-60950-1 Certified

RPR20

* ICE Technology

ICE (Innovation in Converter Excellence) uses state-of-the-art techniques to minimise internal power dissipation and to increase the internal temperature limits to extend the ambient operating temperature range to the maximum.

Refer to Application Notes

Railway Input Voltage Requirements

Nominal Input Voltage	EN50155			NF F 01-510			RPR20		
	Input Range	Min. Input (0.1s)	Max Input (1s)	Input Range	Min. Input (0.1s)	Max Input (1s)	Input Range	Min. Input (0.1s)	Max Input (1s)
24V	16.8~30V	14.4V	33.6V	18~34V	12V	40V	12~36V	9V	40V
48V	33.6~60V	28.8V	67.2V				25~75V	18V	80V
72V	50.4~90V	43.2V	100.8V	50~90V	36V	115V	40~160V	36V	176V
96V	67.2~120V	57.6V	134.4V				40~160V	36V	176V
110V	77~137.5V	66V	154V	77~137V	55V	176V	40~160V	36V	176V

Specifications (typical at nominal input and 25°C unless otherwise noted)

Input Voltage Range (continuous)	complies with EN50155 and NFF 01-510 (Un=24V)		12-36VDC
	complies with EN50155 and NFF 01-510 (Un=48V)		25-75VDC
	complies with EN50155 and NFF 01-510 (Un=72V, 96V & 110V)		40-160VDC
Low Transient operating voltage (100ms)	complies with EN50155 and NFF 01-510		Un x 0.5
High Transient operating voltage (1 second)	complies with EN50155 and NFF 01-510		Un x 1.6
Allowed Input Ripple	complies with EN50155		15%
Input Reflected Ripple	nominal Vin and full load		20mA _{p-p}
Supply Interruption (Perf. Criteria B)	according to EN50155, 5.1.1.2		Class S2
	according to EN50155, 5.1.3		Class C2
Start Up Time	nominal Vin and constant resistive load		2ms typ., 5ms max.
Remote ON/OFF ⁽¹⁾	Logic High, Vin=24V, 48V		Open or 3V < Vr < 5,5V
	Logic High, Vin=110V		Open or 8V < Vr < 60V
	Logic Low		Short or 0V < Vr < 1.2V
Remote OFF input current	Nominal input		2mA typ.
Output Voltage Accuracy	50% Load and nominal Vin		±1.5%
Voltage Adjustability	Single Output only		±10%
Minimum Load			0%
Line Regulation	low line, high line at full load		±0.3%
Load Regulation	10% to 100% full load		±0.5%
Cross Regulation (10% <> 100% Load)	Dual Outputs only		3% typ. / 5% max.
Ripple and Noise (20MHz bandwidth limited)	(measured with 1µF capacitor across outputs)		1% Vout typ. / 3% max.
Temperature Coefficient			±0.04%/°C max.
Transient Response	25% load step change		800µs
Over Load Protection	% of full load at nominal Vin		120% typ.
Short Circuit Protection			Power Limit, automatic recovery
Output Over Voltage Protection	Single Output		Converter shutdown if Vout > Vout nominal + 20%
	Dual Output		Converter shutdown if Vout > Vout nominal + 10%
Isolation Voltage	According to EN50155 12.2.9.2		1500VAC/1 minute
Isolation Resistance	According to EN50155 12.2.9.1		10MΩ min.
Isolation Capacitance			1500pF max.
Operating Frequency			260kHz ± 40kHz
Operating Temperature Range	(T2)	complies with EN50155: 4.1.2 and EN50125-1	-45°C to +85°C
(Ambient Air, Free Convection)	(Tx)	when mounted on a heatsink (see notes)	-45°C to +100°C
Maximum Case Temperature			+120°C
Over Temperature Protection			Internal thermistor

continued on next page

POWERLINE+

DC/DC-Converter

RPR20-S_D Series

Specifications (typical at nominal input and 25°C unless otherwise noted)

Storage Temperature Range	-55°C to +125°C	
Relative Humidity	5% to 95% RH	
Case Material ⁽²⁾	Aluminium	
Weight	43g	
Packing Quantity	4pcs per Tube	
Safety Standards	CE Marked	certified to EN-60950-1, 1st Edition
Thermal Performance	Cold	-40°C /16 Hours
	Dry Heat, Operating	-40°C/+85°C/ 5 Cycles
complies to EN50155: 12.2.3/4/5	Damp Heat, Cyclic	+25°C/+55°C, 95%RH / 2 x 24 Hours
Vibration, Shock & Bump (complies with EN61373, Category 1 Class B)	Vibration	5-150Hz, X:0.7m/s ² , Y:0.45m/s ² , Z:1m/s ² , 30 mins
	Shock	5g/30ms/18 shocks
Input Filter	Built-in Pi Filter	
Conducted Emissions	EN50121-3-2***	Class A
Radiated Emissions	EN50121-3-2***	Class A
ESD	EN50121-3-2***	Perf. Criteria B
Radiated Immunity	EN50121-3-2***	Perf. Criteria A
Fast Transient	EN50121-3-2***	Perf. Criteria A
Surge	EN50121-3-2***	Perf. Criteria B
Conducted Immunity	EN50121-3-2***	Perf. Criteria A
MTBF calculated according to BELLCORE TR-NWT-000332 Case I: 50% Stress, Temperature at 50°C (Ground Benign)	2195 x 10 ³ hours	

***with filter circuit

Typical Control Pin Application Circuit

The CTRL pin can be directly driven with a 24V or 48V signal, or via a transistor with a 5V signal.

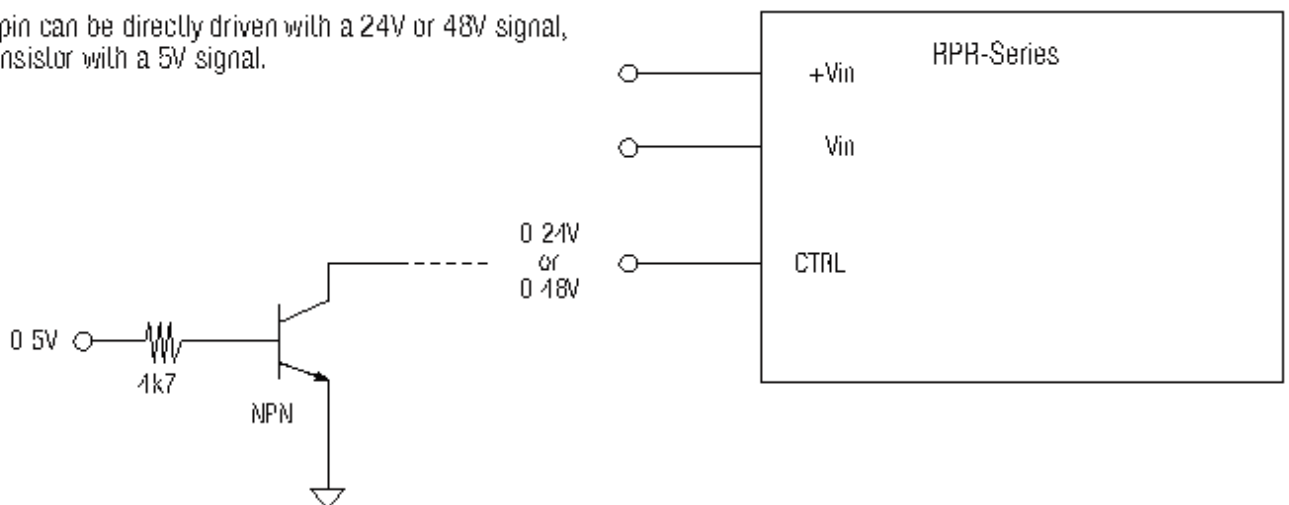

EN50155 / NF F 01-510 Input Filter

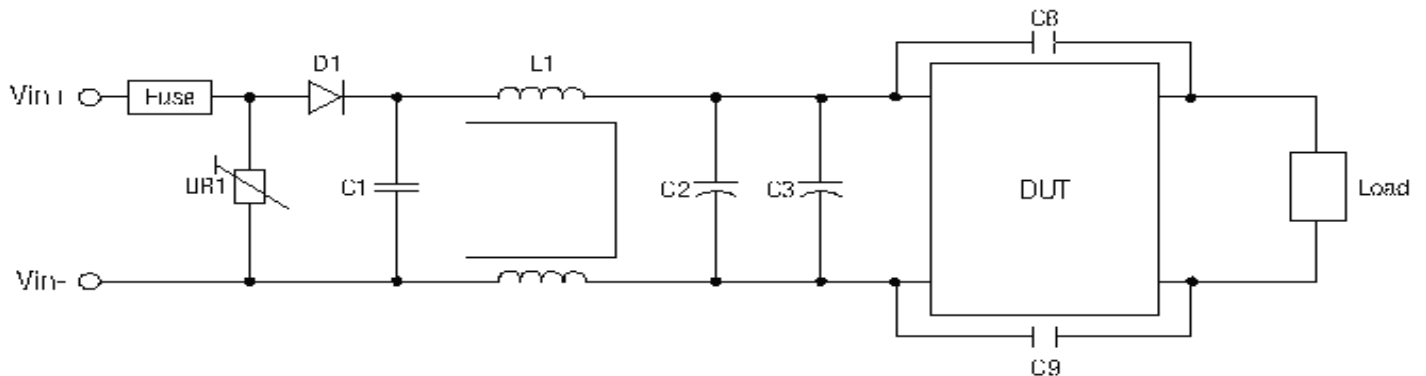

Table

Module	Standard	UR1	D1	C1	L1	C2	C3	C8,C9
24V	EN50155	MOV 14D361K	100V/6A	6,8 μ F/50V	550 μ H \pm 20%	330 μ F/ 50VDC	330 μ F/ 50VDC	4,7nF/3kV
48V	EN50155	MOV 14D361K	200V/3A	220nF/100V	550 μ H \pm 20%	330 μ F/ 100VDC	330 μ F/ 100VDC	4,7nF/3kV
110V	EN50155	MOV 14D361K	300V/3A	470nF/250V	1200 μ H \pm 20%	330 μ F/ 250VDC	330 μ F/ 250VDC	4,7nF/3kV

Notes :

- The ON/OFF pin voltage is referenced to negative input. The pin is pulled high internally.
ON/OFF control is standard with positive logic: e.g. RPR20-4805D-B.
Positive logic: 0= OFF, 1 = ON. The converter will be ON if the CTRL is left open.
- To ensure a good all-round electrical contact, the baseplate is pressed firmly into place within the aluminium housing. The hydraulic press can leave tooling marks and deformations to both the housing and baseplate. The case is anodised aluminium, so there will be natural variations in the case colour and the aluminium is not scratch resistant. Any resultant marks, scratches and colour variations are cosmetic only and do not affect the operation or performance of the converters.
- The converter is supplied with a protective adhesive tape to keep the top surface clean. The tape is heat resistant and the converter can be soldered into place without removing the tape. The tape should be removed just before final installation.
- The RPR series are optionally available with a ribbed heatsink case style. They will then meet Tx requirements without an external heat-sink. Please contact your RECOM supplier for more information.

POWERLINE+

DC/DC-Converter

Recommended PCB Layout

RPR20-S_D Series

Baseplate Case- suggested PCB layout

Single Output

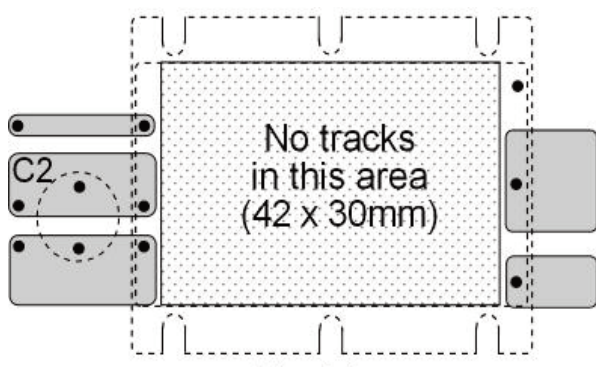

Top View

Dual Output

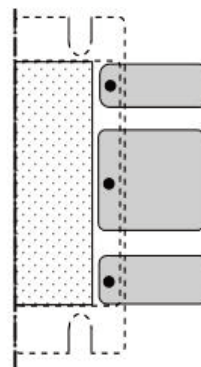

Input Fuse is recommended. Recommended fuse rating = double maximum input current, time delay type.

To ensure optimum thermal performance, use large areas of copper on the PCB to assist with heat dissipation and mount the converter vertically.

Package Style and Pinning (mm)

Baseplate Case (-B Suffix)

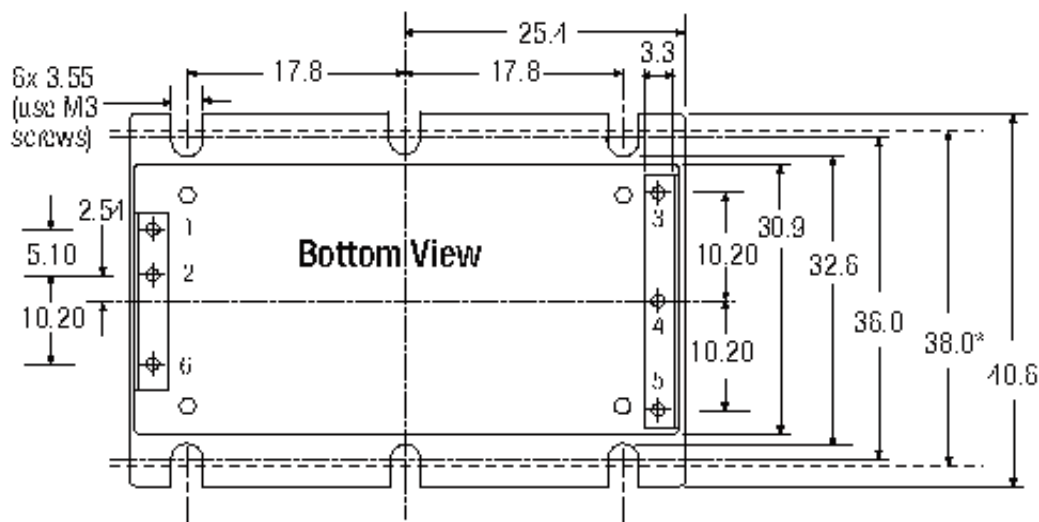
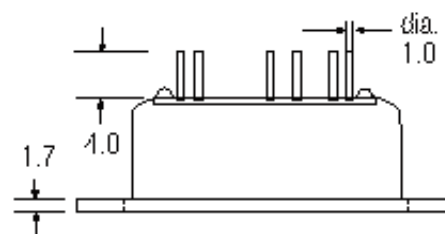
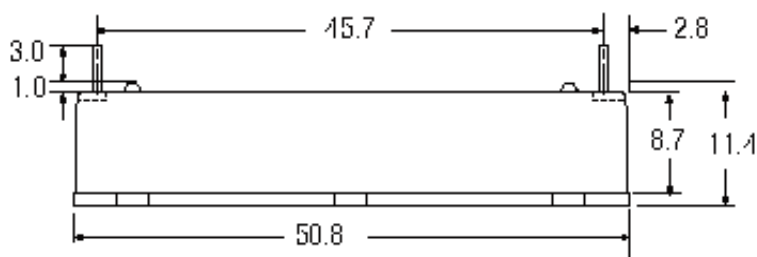

Bottom View

NOTE: Single output pinout is different for the -B version!

Pin Connections

Pin #	Single	Dual
1	+Vin	+Vin
2	-Vin	-Vin
3	+Vout	+Vout
4	-Vout	Com
5	Trim	-Vout
6	CTRL	CTRL

Pin Pitch Tolerance ± 0.35 mm

*Recommended Fixing Centres

POWERLINE+

DC/DC-Converter

Package Style and Pinning (mm)

RPR20-S_D Series

Baseplate Case Fixing - Mounting onto Heatsink/Bulkhead

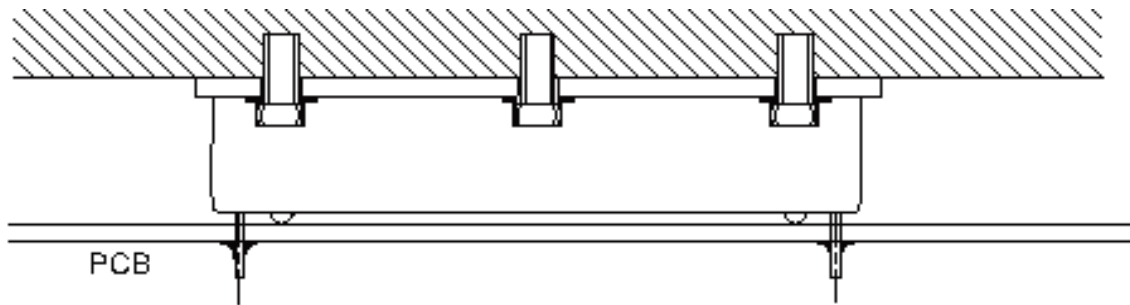

Baseplate Case Fixing - Anti Vibration Mounting onto PCB

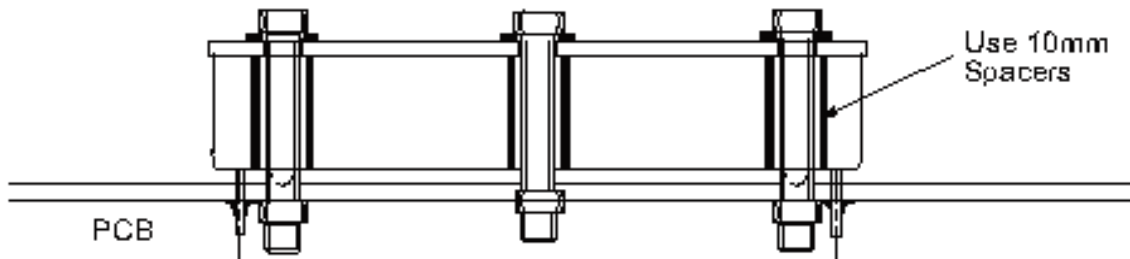

I.C.E Technology

ICE (Innovation in Converter Excellence) Technology uses a combination of techniques to minimise internal heat dissipation and maximise the heat transfer to ambient to create a new converter series which offers high end performance at a price which is significantly lower than conventional specialist converters.

The exact details of this technology must remain secret, but the following brief resume describes the main features of this technological breakthrough:

Minimising internal heat dissipation

The difference between the input power and the output power is the internal power dissipation which generates heat within the converter.

If the converter is inefficient at converting power, then adding external heat sinks, base-plates or fans are remedies that cure the symptoms rather than address the illness.

First and foremost, the converter must have the highest possible efficiency over the entire input voltage range and load conditions. Most power converters are designed to be most efficient at 25°C, full load and nominal input voltage and thus offer a compromise performance when lightly loaded or operated at the maximum ambient temperature.

ICE Technology uses state-of-the-art techniques to improve power conversion efficiency by approximately 2% compared to standard converters. A two per cent improvement may not sound much, but the difference between a converter with 88% efficiency and one with 90% efficiency is a 17% reduction in the dissipated power. In addition, when lightly loaded, the converters enter a power saving mode and draw only a few milliamps from the supply.

Maximising heat transfer

The rate of heat transfer between a hot body and its cooler surroundings is given by Fourier's Law:

$$q = -k \cdot \Delta T$$

where

q = rate of heat transfer

k = thermal conductivity

and ΔT = temperature difference

If k can be made larger, then the rate of heat transfer can still match or exceed the rate of heat generation at lower temperature differences ΔT and the converter will have an extended operating temperature range.

Techniques to improve thermal conductivity

ICE Technology splits the thermal conductivity problem into two areas and attacks each area separately using different techniques.

Firstly, the internal heat transfer to the case is maximised by a combination of novel converter construction and clever thermal design.

ICE converters use a construction where the hottest components (the switching FET, the transformer and the synchronous rectification FETs) are placed closest to the case wall. This method of construction makes the manufacture of the converter more difficult, but this lack of compromise reduces greatly the internal thermal impedance.

Secondly, the rate of transfer of heat to the surroundings is improved by a novel case construction which incorporates a built-in heat sink. The case is also made from thick aircraft grade aluminium rather than thin nickel-plated copper to provide a better thermal junction between the case and the high thermal conductivity silicone potting material used inside the converter.

Maximising high temperature performance

The final technique used in the construction of ICE Technology converters is to use high temperature internal components. The maximum operating temperature of a converter is dependent on the lowest maximum permissible operating temperature of any the components used. If the capacitors are rated up to +85°C and the FETs are rated at +160°C, then the limiting factor is the capacitor temperature of +85°C.

The temperature of the ferrite core used in the transformer is also an important limiting factor. If the transformer core temperature exceeds the Curie temperature of the ferrite, then the transformer rapidly loses performance.

ICE Technology converter uses high temperature grade components to permit a case temperature of +115°C maximum. This allows operation at up to +85°C ambient without the need for fans to blow air over the converter.



Electromagnetic Compatibility

Although high temperature performance is a significant feature of ICE Technology design, it does not end there.

ICE Technology also addresses the need for electromagnetic compatibility by incorporating a built-in EN55022 Class B grade filter inside the converter. The converter has been designed from the ground up to meet EMC requirements rather than a conventional design process where first the converter is optimised for performance and then an external filter is added to combat the conducted interference.

By including the filter on the main PCB of the converter, the track path lengths and impedances between the filter and the noise-generating components are reduced to the minimum and consequently smaller value filter components can be used that fit into the compact case dimensions of the Powerline+ converters without compromising on filter performance.

Safety and Protection

ICE Technology converters are fully protected from output short circuits, overload, output over-voltage and over-temperature. In addition, they feature under-voltage lockout that will automatically disable the converter if the input voltage falls below the minimum level.

The output is current limited which means that temporary overloads can occur without the converter shutting down. When overloaded, the output voltage will decrease to keep the maximum power constant. For the 40W and 50W converters, if the overload is too high, the converter will go into hiccup short circuit protection mode. In this mode, the converter will attempt to reconnect power every 10-20 milliseconds.

Output overvoltage protection is monitored by a separate and independent feedback circuit and an internal thermistor sensor is used to protect the converter against overheating.

POWERLINE+ Application Notes

DC/DC-Converter

Powerline Plus Output Trim Tables



Output Voltage Trimming:

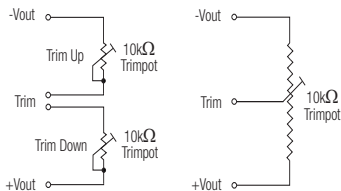

Single output Powerline Plus converters offer the feature of trimming the output voltage over a certain range around the nominal value by using external trim resistors.

No general equation can be given for calculating the trim resistors, but the

following trimtables give typical values for choosing these trimming resistors.

If voltages between the given trim points are required, extrapolate between the two nearest given values to work out the resistor required or use a variable resistor to set the output voltage.

RPRxx-xx3.3S (all types)

Trim up	1	2	3	4	5	6	7	8	9	10	%
Vout =	3,333	3,366	3,399	3,432	3,465	3,498	3,531	3,564	3,597	3,63	Volts
R _U =	72.8	34.4	21.2	14.4	9.9	7.2	5.3	3.88	2.74	1.84	KOhms
Trim down	1	2	3	4	5	6	7	8	9	10	%
Vout =	3,267	3,234	3,201	3,168	3,135	3,102	3,069	3,036	3,003	2,97	Volts
R _D =	101.3	36.2	21.0	13.65	9.2	6.0	4.12	2.56	1.34	0.87	KOhms

RPRxx-xx05S (all types)

Trim up	1	2	3	4	5	6	7	8	9	10	%
Vout =	5,05	5,1	5,15	5,2	5,25	5,3	5,35	5,4	5,45	5,5	Volts
R _U =	109.7	51	31.2	20.3	14.2	9.87	7.1	5.0	3.38	2.08	KOhms
Trim down	1	2	3	4	5	6	7	8	9	10	%
Vout =	4,95	4,9	4,85	4,8	4,75	4,7	4,65	4,6	4,55	4,5	Volts
R _D =	127.6	55.8	33.0	20.2	14.2	9.46	5.97	3.6	1.77	0.28	KOhms

RPRxx-xx12S (all types)

Trim up	1	2	3	4	5	6	7	8	9	10	%
Vout =	12,12	12,24	12,36	12,48	12,6	12,72	12,84	12,96	13,08	13,2	Volts
R _U =	270	120	70	45.2	30.1	19.8	12.8	7.52	3.31	0	KOhms
Trim down	1	2	3	4	5	6	7	8	9	10	%
Vout =	11,88	11,76	11,64	11,52	11,4	11,28	11,16	11,04	10,92	10,8	Volts
R _D =	270	120	70	45.2	30.1	19.8	12.8	7.52	3.31	0	KOhms

RPRxx-xx15S (all types)

Trim up	1	2	3	4	5	6	7	8	9	10	%
Vout =	15,15	15,3	15,45	15,6	15,75	15,9	16,05	16,2	16,35	16,5	Volts
R _U =	337	150	87	56.2	37.5	24.7	16	9.4	4.16	0	KOhms
Trim down	1	2	3	4	5	6	7	8	9	10	%
Vout =	14,85	14,7	14,55	14,4	14,25	14,1	13,95	13,8	13,65	13,5	Volts
R _D =	337	150	87	56.2	37.5	24.7	16	9.4	4.16	0	KOhms

POWERLINE+ Application Notes

DC/DC-Converter

Block Diagrams

Powerline Plus Output Trim Tables

RPRxx-xx24S (all types)

Trim up	1	2	3	4	5	6	7	8	9	10	%
Vout =	24,24	24,48	24,72	24,96	25,20	25,44	24,68	25,92	26,16	26,4	Volts
R _U =	270	120	70	45.2	30.1	19.8	12.8	7.52	3.31	0	KOhms
Trim down	1	2	3	4	5	6	7	8	9	10	%
Vout =	23,76	23,52	23,28	23,04	22,80	22,56	22,32	22,08	21,84	21,6	Volts
R _D =	270	120	70	45.2	30.1	19.8	12.8	7.52	3.31	0	KOhms

Block Diagrams

Single Output - 3.3V and 5V Outputs

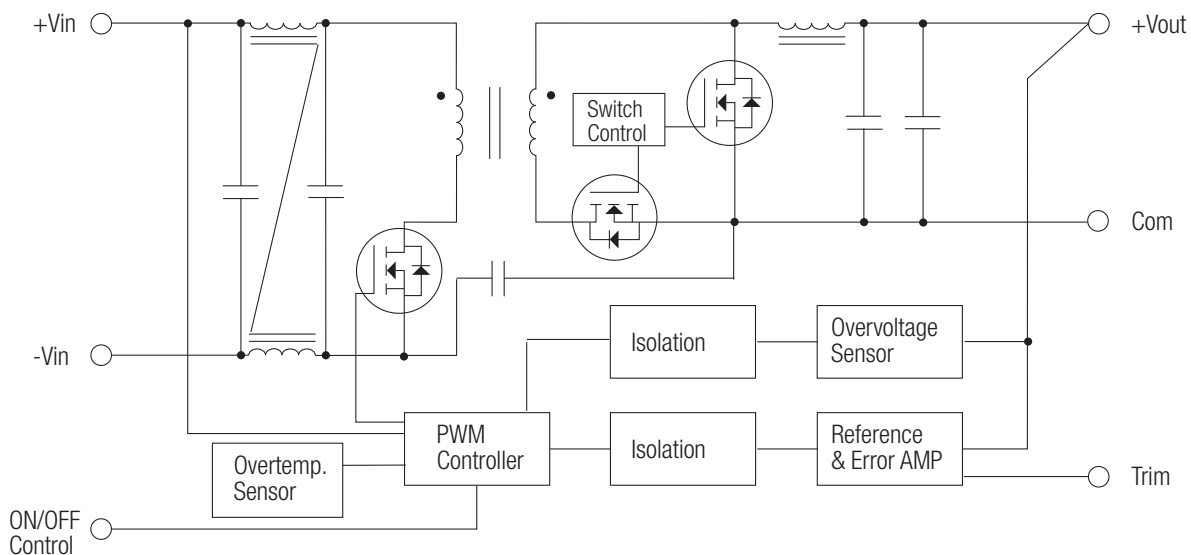

Single Output - all other outputs

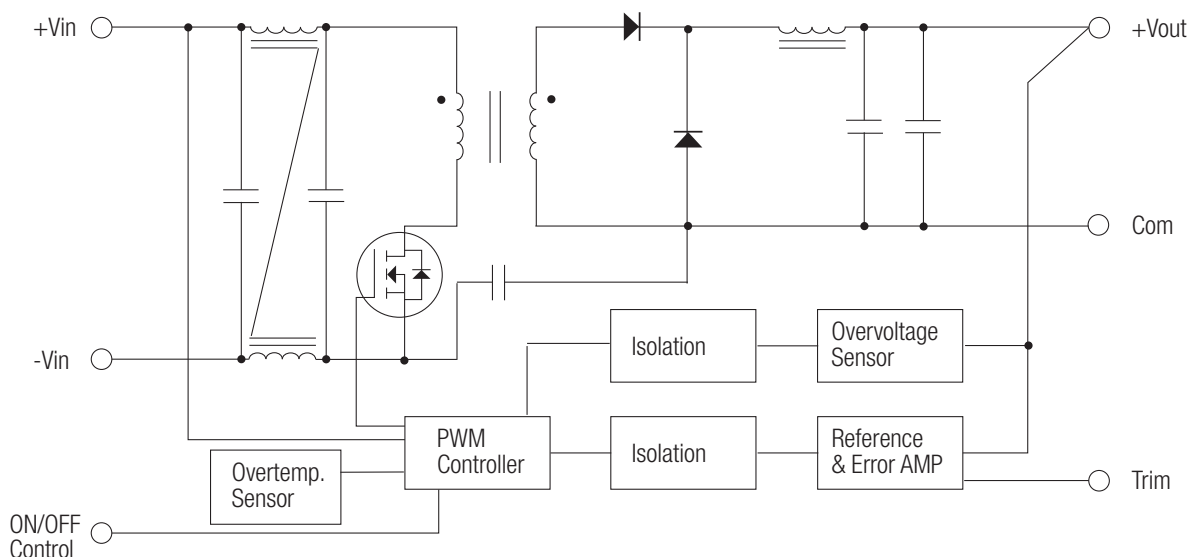

POWERLINE+ Application Notes

DC/DC-Converter

Block Diagrams

Block Diagrams

Dual Output

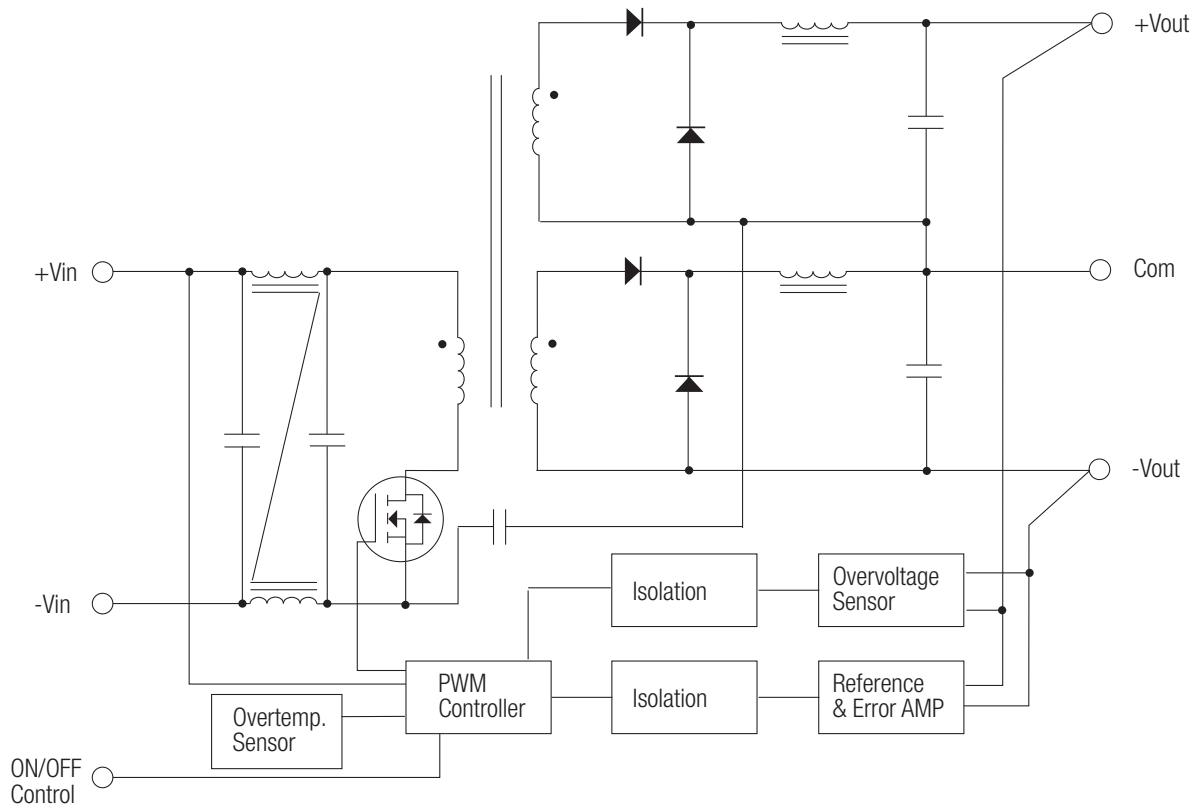

App Notes

Features

ICE Technology*

- T2 Temperature Range without Derating
- 120°C Maximum Case Temperature
- -45°C Minimum Operating Temperature
- EN 50155 Certified
- EN 50121-3-2 Certified
- CE Marked
- 24, 48 and 110VDC Input Ranges
- Six Sided Shielded Enclosure
- Baseplate Case Styles
- Efficiency to >89%
- Low Quiescent Current

Description

The RPR30 series DC/DC converters are designed for railway rolling stock applications. Besides covering all the input voltages from 24VDC up to 110VDC, the converters have a very wide operating temperature range of -45°C to +120°C. The RPR30 has a baseplate case for high vibration or bulkhead-mounting applications. It is EN 50155 and EN 50121-3-2 certified.

Selection Guide 24V, 48V and 110V Input Types

Part Number	Nominal Input VDC	Nom. Input Range VDC	Lockout Voltage VDC	Output Voltage VDC	Output Current mA
RPR30-243.3S-B	24	12-36	8	3.3	9100
RPR30-2405S-B	24	12-36	8	5	6000
RPR30-2412S-B	24	12-36	8	12	2500
RPR30-2415S-B	24	12-36	8	15	2000
RPR30-2424S-B	24	12-36	8	24	1250
RPR30-483.3S-B	48	25-75	17	3.3	9100
RPR30-4805S-B	48	25-75	17	5	6000
RPR30-4812S-B	48	25-75	17	12	2500
RPR30-4815S-B	48	25-75	17	15	2000
RPR30-4824S-B	48	25-75	17	24	1250
RPR30-1103.3S-B	110	40-160	36	3.3	9100
RPR30-11005S-B	110	40-160	36	5	6000
RPR30-11012S-B	110	40-160	36	12	2500
RPR30-11015S-B	110	40-160	36	15	2000
RPR30-11024S-B	110	40-160	36	24	1250
RPR30-2412D-B	24	12-36	8	±12	±1250
RPR30-2415D-B	24	12-36	8	±15	±1000
RPR30-2424D-B	24	12-36	8	±24	±620
RPR30-4812D-B	48	25-75	17	±12	±1250
RPR30-4815D-B	48	25-75	17	±15	±1000
RPR30-4824D-B	48	25-75	17	±24	±620
RPR30-11012D-B	110	40-160	36	±12	±1250
RPR30-11015D-B	110	40-160	36	±15	±1000
RPR30-11024D-B	110	40-160	36	±24	±620

For other CTRL logic or case style options please contact RECOM for availability.

POWERLINE+
Railway-Converter
with 5 year Warranty

RECOM

**30 Watt
Single &
Dual Output**



**EN-50155 Certified
EN-60950 Certified**

RPR30

* ICE Technology

ICE (Innovation in Converter Excellence) uses state-of-the-art techniques to minimise internal power dissipation and to increase the internal temperature limits to extend the ambient operating temperature range to the maximum.

Refer to Application Notes

Railway Input Voltage Requirements

Nominal Input Voltage	EN50155			NF F 01-510			RPR30		
	Input Range	Min. Input (0.1s)	Max Input (1s)	Input Range	Min. Input (0.1s)	Max Input (1s)	Input Range	Min. Input (0.1s)	Max Input (1s)
24V	16.8~30V	14.4V	33.6V	18~34V	12V	40V	12~36V	9V	40V
48V	33.6~60V	28.8V	67.2V				25~75V	18V	80V
72V	50.4~90V	43.2V	100.8V	50~90V	36V	115V	40~160V	36V	176V
96V	67.2~120V	57.6V	134.4V				40~160V	36V	176V
110V	77~137.5V	66V	154V	77~137V	55V	176V	40~160V	36V	176V

Specifications (typical at nominal input and 25°C unless otherwise noted)

Input Voltage Range (continuous)		complies with EN50155 and NFF 01-510 (Un=24V)	12-36VDC
		complies with EN50155 and NFF 01-510 (Un=48V)	25-75VDC
		complies with EN50155 and NFF 01-510 (Un=72V, 96V & 110V)	40-160VDC
Low Transient operating voltage (100ms)		complies with EN50155 and NFF 01-510	Un x 0.5
High Transient operating voltage (1 second)		complies with EN50155 and NFF 01-510	Un x 1.6
Allowed Input Ripple		complies with EN50155	15%
Input Reflected Ripple		nominal Vin and full load	20mA _{p-p}
Supply Interruption (Perf. Criteria B)		according to EN50155, 5.1.1.2	Class S2
		according to EN50155, 5.1.3	Class C2
Start Up Time		nominal Vin and constant resistive load	2ms typ., 5ms max.
Remote ON/OFF ⁽¹⁾		Logic High, Vin=24V, 48V	Open or 3V < Vr < 5,5V
		Logic High, Vin=110V	Open or 8V < Vr < 60V
		Logic Low	Short or 0V < Vr < 1.2V
Remote OFF input current		Nominal input	2mA typ.
Output Voltage Accuracy		50% Load and nominal Vin	±1.5%
Voltage Adjustability		Single Output only	±10%
Minimum Load			0%
Line Regulation		low line, high line at full load	±0.3%
Load Regulation		10% to 100% full load	±0.5%
Cross Regulation (10% <> 100% Load)		Dual Outputs only	3% typ. / 5% max.
Ripple and Noise (20MHz bandwidth limited)		(measured with 1µF capacitor across outputs)	1% Vout typ. / 3% max.
Temperature Coefficient			±0.04%/°C max.
Transient Response		25% load step change	800µs
Over Load Protection		% of full load at nominal Vin	120% typ.
Short Circuit Protection			Power Limit, automatic recovery
Output Over Voltage Protection		Single Output	Converter shutdown if Vout > Vout nominal + 20%
		Dual Output	Converter shutdown if Vout > Vout nominal + 10%
Isolation Voltage		According to EN50155 12.2.9.2	Tested at 1500VAC/1 minute
Isolation Resistance		According to EN50155 12.2.9.1	10MΩ min.
Isolation Capacitance			1500pF max.
Operating Frequency			260kHz ± 40kHz
Operating Temperature Range (Ambient Air, Free Convection)	(T2) (Tx)	complies with EN50155: 4.1.2 and EN50125-1 with derating	-45°C to +85°C -45°C to +100°C
Maximum Case Temperature			+120°C
Over Temperature Protection			Internal thermistor

continued on next page

POWERLINE+

DC/DC-Converter

RPR30-S_D Series

Specifications (typical at nominal input and 25°C unless otherwise noted)

Storage Temperature Range	-55°C to +125°C	
Relative Humidity	5% to 95% RH	
Case Material ⁽²⁾	Aluminium	
Weight	43g	
Packing Quantity	4pcs per Tube	
Safety Standards	CE Marked	certified to EN-60950-1, 1st Edition
Thermal Performance	Cold	-40°C /16 Hours
	Dry Heat, Operating	-40°C/+85°C/ 5 Cycles
complies to EN50155: 12.2.3/4/5	Damp Heat, Cyclic	+25°C/+55°C, 95%RH / 2 x 24 Hours
Vibration, Shock & Bump (complies with EN61373, Category 1 Class B)	Vibration	5-150Hz, X:0.7m/s ² , Y:0.45m/s ² , Z:1m/s ² , 30 mins
	Shock	5g/30ms/18 shocks
Input Filter	Built-in Pi Filter	
Conducted Emissions	EN50121-3-2***	Class A
Radiated Emissions	EN50121-3-2***	Class A
ESD	EN50121-3-2***	Perf. Criteria B
Radiated Immunity	EN50121-3-2***	Perf. Criteria A
Fast Transient	EN50121-3-2***	Perf. Criteria A
Surge	EN50121-3-2***	Perf. Criteria B
Conducted Immunity	EN50121-3-2***	Perf. Criteria A
MTBF calculated according to BELLCORE TR-NWT-000332 Case I: 50% Stress, Temperature at 50°C (Ground Benign)	2195 x 10 ³ hours	

***with filter circuit

RPR30

Typical Control Pin Application Circuit

The CTRL pin can be directly driven with a 24V or 48V signal, or via a transistor with a 5V signal.

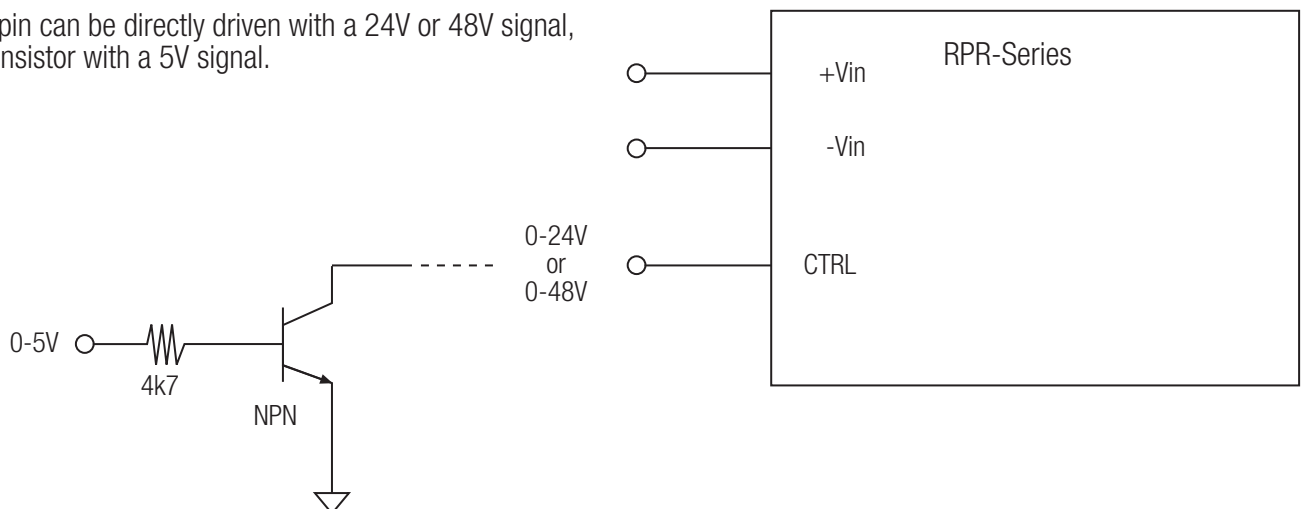

POWERLINE+

DC/DC-Converter

Typical Application Circuit

EN50155 / NF F 01-510 Input Filter

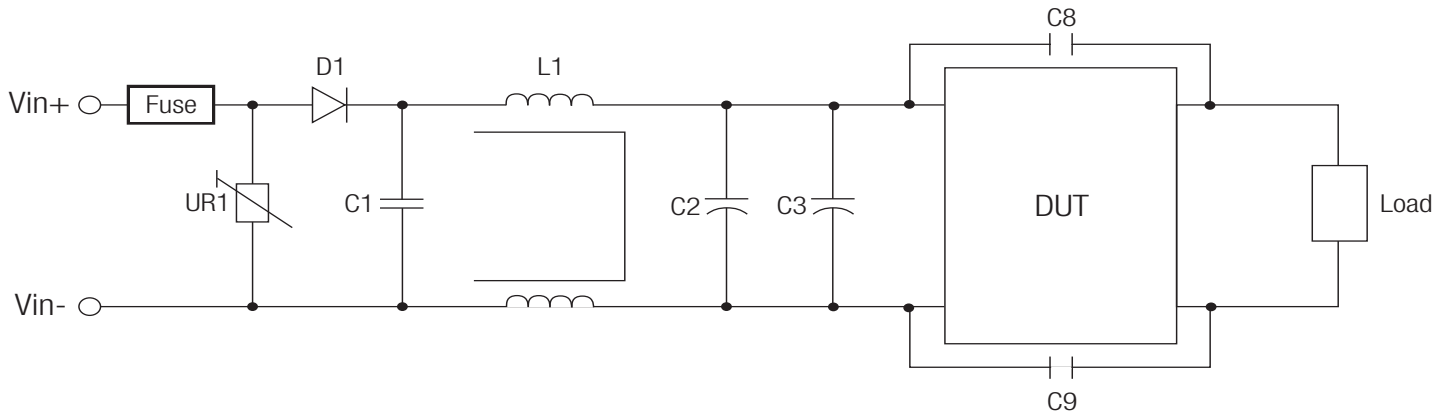

Table

Module	Standard	UR1	D1	C1	L1	C2	C3	C8,C9
24V	EN50155	MOV 14D361K	100V/6A	6,8μF/50V	550μH±20%	330μF/ 50VDC	330μF/ 50VDC	4,7nF/3kV
48V	EN50155	MOV 14D361K	200V/3A	220nF/100V	550μH±20%	330μF/ 100VDC	330μF/ 100VDC	4,7nF/3kV
110V	EN50155	MOV 14D361K	300V/3A	470nF/250V	1200μH±20%	330μF/ 250VDC	330μF/ 250VDC	4,7nF/3kV

Notes :

- The ON/OFF pin voltage is referenced to negative input. The pin is pulled high internally.
ON/OFF control is standard with positive logic: e.g. RPR20-2405S, RPR20-4805D-B.
Positive logic: 0= OFF, 1 = ON. The converter will be ON if the CTRL is left open.
- To ensure a good all-round electrical contact, the baseplate is pressed firmly into place within the aluminium housing. The hydraulic press can leave tooling marks and deformations to both the housing and baseplate. The case is anodised aluminium, so there will be natural variations in the case colour and the aluminium is not scratch resistant. Any resultant marks, scratches and colour variations are cosmetic only and do not affect the operation or performance of the converters.
- The converter is supplied with a protective adhesive tape to keep the top surface clean. The tape is heat resistant and the converter can be soldered into place without removing the tape. The tape should be removed just before final installation.
- The RPR series are optionally available with a ribbed heatsink case style. They will then meet Tx requirements without an external heat-sink. Please contact your RECOM supplier for more information.

POWERLINE+

DC/DC-Converter

Recommended PCB Layout

RPR30-S_D Series

Baseplate Case- suggested PCB layout

Single Output

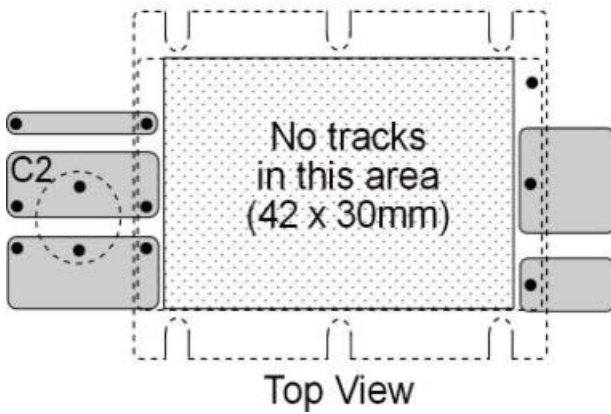

Dual Output

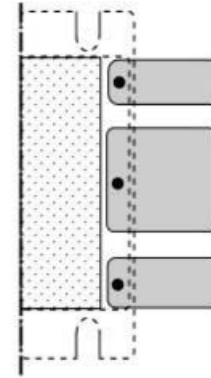

Input Fuse is recommended.
Recommended fuse rating = double maximum input current, time delay type.

To ensure optimum thermal performance, use large areas of copper on the PCB to assist with heat dissipation and mount the converter vertically.

Package Style and Pinning (mm)

Baseplate Case (-B Suffix)

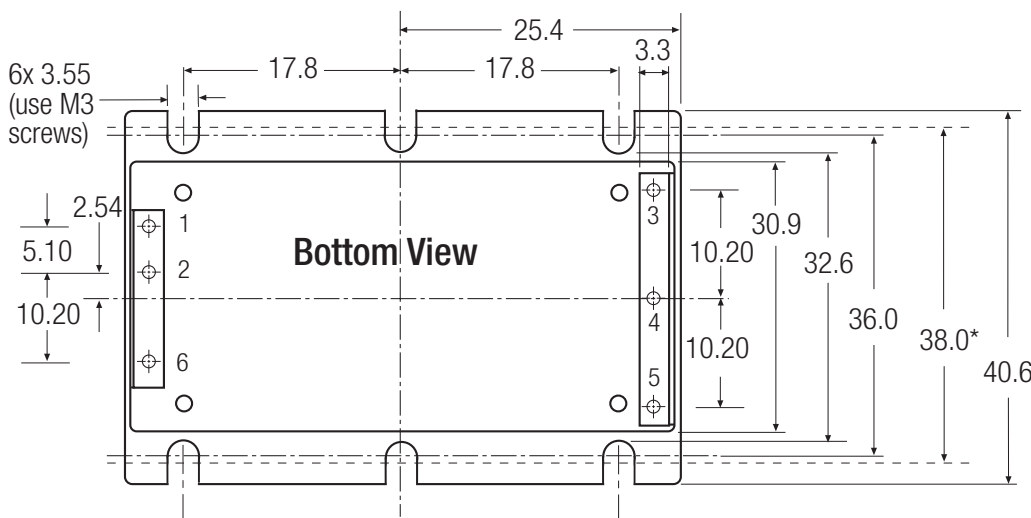
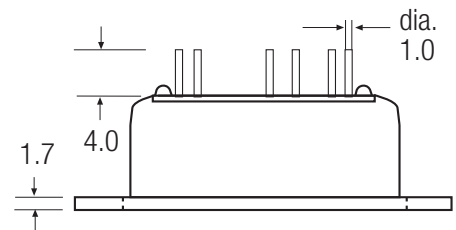
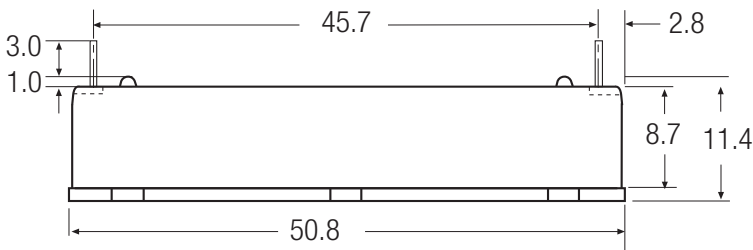

Pin Connections

Pin #	Single	Dual
1	+Vin	+Vin
2	-Vin	-Vin
3	+Vout	+Vout
4	-Vout	Com
5	Trim	-Vout
6	CTRL	CTRL

Pin Pitch Tolerance ± 0.35 mm

*Recommended Fixing Centres

POWERLINE+

DC/DC-Converter

Package Style and Pinning (mm)

RPR30-S_D Series

Baseplate Case Fixing - Mounting onto Heatsink/Bulkhead

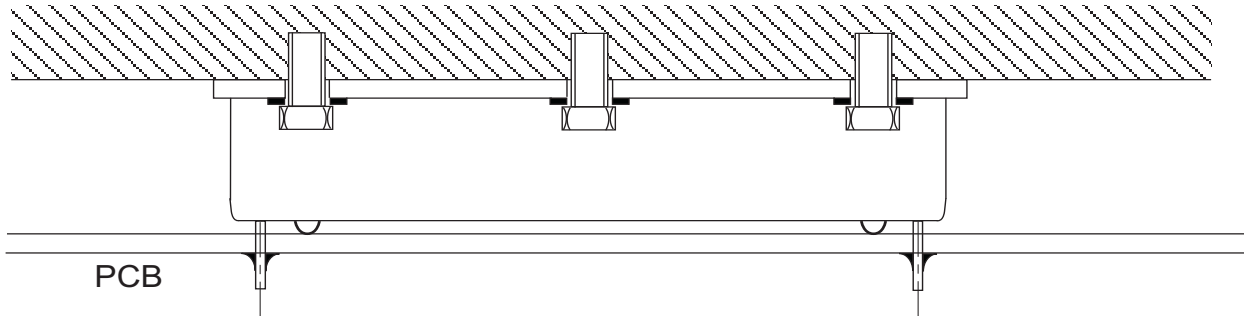

Baseplate Case Fixing - Anti Vibration Mounting onto PCB

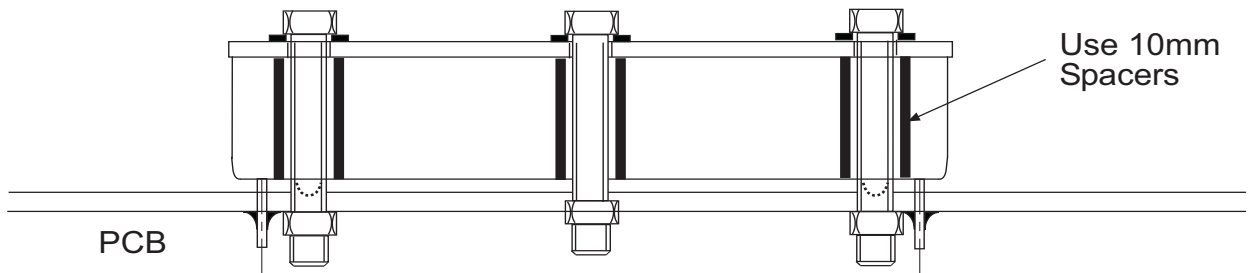

I.C.E Technology

ICE (Innovation in Converter Excellence) Technology uses a combination of techniques to minimise internal heat dissipation and maximise the heat transfer to ambient to create a new converter series which offers high end performance at a price which is significantly lower than conventional specialist converters.

The exact details of this technology must remain secret, but the following brief resume describes the main features of this technological breakthrough:

Minimising internal heat dissipation

The difference between the input power and the output power is the internal power dissipation which generates heat within the converter.

If the converter is inefficient at converting power, then adding external heat sinks, base-plates or fans are remedies that cure the symptoms rather than address the illness.

First and foremost, the converter must have the highest possible efficiency over the entire input voltage range and load conditions. Most power converters are designed to be most efficient at 25°C, full load and nominal input voltage and thus offer a compromise performance when lightly loaded or operated at the maximum ambient temperature.

ICE Technology uses state-of-the-art techniques to improve power conversion efficiency by approximately 2% compared to standard converters. A two per cent improvement may not sound much, but the difference between a converter with 88% efficiency and one with 90% efficiency is a 17% reduction in the dissipated power. In addition, when lightly loaded, the converters enter a power saving mode and draw only a few milliamps from the supply.

Maximising heat transfer

The rate of heat transfer between a hot body and its cooler surroundings is given by Fourier's Law:

$$q = -k \cdot \Delta T$$

where

q = rate of heat transfer

k = thermal conductivity

and ΔT = temperature difference

If k can be made larger, then the rate of heat transfer can still match or exceed the rate of heat generation at lower temperature differences ΔT and the converter will have an extended operating temperature range.

Techniques to improve thermal conductivity

ICE Technology splits the thermal conductivity problem into two areas and attacks each area separately using different techniques.

Firstly, the internal heat transfer to the case is maximised by a combination of novel converter construction and clever thermal design.

ICE converters use a construction where the hottest components (the switching FET, the transformer and the synchronous rectification FETs) are placed closest to the case wall. This method of construction makes the manufacture of the converter more difficult, but this lack of compromise reduces greatly the internal thermal impedance.

Secondly, the rate of transfer of heat to the surroundings is improved by a novel case construction which incorporates a built-in heat sink. The case is also made from thick aircraft grade aluminium rather than thin nickel-plated copper to provide a better thermal junction between the case and the high thermal conductivity silicone potting material used inside the converter.

Maximising high temperature performance

The final technique used in the construction of ICE Technology converters is to use high temperature internal components. The maximum operating temperature of a converter is dependent on the lowest maximum permissible operating temperature of any the components used. If the capacitors are rated up to +85°C and the FETs are rated at +160°C, then the limiting factor is the capacitor temperature of +85°C.

The temperature of the ferrite core used in the transformer is also an important limiting factor. If the transformer core temperature exceeds the Curie temperature of the ferrite, then the transformer rapidly loses performance.

ICE Technology converter uses high temperature grade components to permit a case temperature of +115°C maximum. This allows operation at up to +85°C ambient without the need for fans to blow air over the converter.



Electromagnetic Compatibility

Although high temperature performance is a significant feature of ICE Technology design, it does not end there.

ICE Technology also addresses the need for electromagnetic compatibility by incorporating a built-in EN55022 Class B grade filter inside the converter. The converter has been designed from the ground up to meet EMC requirements rather than a conventional design process where first the converter is optimised for performance and then an external filter is added to combat the conducted interference.

By including the filter on the main PCB of the converter, the track path lengths and impedances between the filter and the noise-generating components are reduced to the minimum and consequently smaller value filter components can be used that fit into the compact case dimensions of the Powerline+ converters without compromising on filter performance.

Safety and Protection

ICE Technology converters are fully protected from output short circuits, overload, output over-voltage and over-temperature. In addition, they feature under-voltage lockout that will automatically disable the converter if the input voltage falls below the minimum level.

The output is current limited which means that temporary overloads can occur without the converter shutting down. When overloaded, the output voltage will decrease to keep the maximum power constant. For the 40W and 50W converters, if the overload is too high, the converter will go into hiccup short circuit protection mode. In this mode, the converter will attempt to reconnect power every 10-20 milliseconds.

Output overvoltage protection is monitored by a separate and independent feedback circuit and an internal thermistor sensor is used to protect the converter against overheating.

POWERLINE+ Application Notes

DC/DC-Converter

Powerline Plus Output Trim Tables



Output Voltage Trimming:

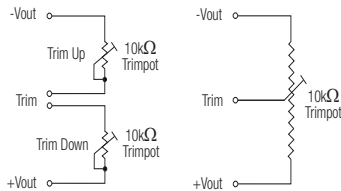

Single output Powerline Plus converters offer the feature of trimming the output voltage over a certain range around the nominal value by using external trim resistors.

No general equation can be given for calculating the trim resistors, but the

following trimtables give typical values for choosing these trimming resistors.

If voltages between the given trim points are required, extrapolate between the two nearest given values to work out the resistor required or use a variable resistor to set the output voltage.

RPRxx-xx3.3S (all types)

Trim up	1	2	3	4	5	6	7	8	9	10	%
Vout =	3,333	3,366	3,399	3,432	3,465	3,498	3,531	3,564	3,597	3,63	Volts
R _U =	72.8	34.4	21.2	14.4	9.9	7.2	5.3	3.88	2.74	1.84	KOhms
Trim down	1	2	3	4	5	6	7	8	9	10	%
Vout =	3,267	3,234	3,201	3,168	3,135	3,102	3,069	3,036	3,003	2,97	Volts
R _D =	101.3	36.2	21.0	13.65	9.2	6.0	4.12	2.56	1.34	0.87	KOhms

RPRxx-xx05S (all types)

Trim up	1	2	3	4	5	6	7	8	9	10	%
Vout =	5,05	5,1	5,15	5,2	5,25	5,3	5,35	5,4	5,45	5,5	Volts
R _U =	109.7	51	31.2	20.3	14.2	9.87	7.1	5.0	3.38	2.08	KOhms
Trim down	1	2	3	4	5	6	7	8	9	10	%
Vout =	4,95	4,9	4,85	4,8	4,75	4,7	4,65	4,6	4,55	4,5	Volts
R _D =	127.6	55.8	33.0	20.2	14.2	9.46	5.97	3.6	1.77	0.28	KOhms

RPRxx-xx12S (all types)

Trim up	1	2	3	4	5	6	7	8	9	10	%
Vout =	12,12	12,24	12,36	12,48	12,6	12,72	12,84	12,96	13,08	13,2	Volts
R _U =	270	120	70	45.2	30.1	19.8	12.8	7.52	3.31	0	KOhms
Trim down	1	2	3	4	5	6	7	8	9	10	%
Vout =	11,88	11,76	11,64	11,52	11,4	11,28	11,16	11,04	10,92	10,8	Volts
R _D =	270	120	70	45.2	30.1	19.8	12.8	7.52	3.31	0	KOhms

RPRxx-xx15S (all types)

Trim up	1	2	3	4	5	6	7	8	9	10	%
Vout =	15,15	15,3	15,45	15,6	15,75	15,9	16,05	16,2	16,35	16,5	Volts
R _U =	337	150	87	56.2	37.5	24.7	16	9.4	4.16	0	KOhms
Trim down	1	2	3	4	5	6	7	8	9	10	%
Vout =	14,85	14,7	14,55	14,4	14,25	14,1	13,95	13,8	13,65	13,5	Volts
R _D =	337	150	87	56.2	37.5	24.7	16	9.4	4.16	0	KOhms

POWERLINE+ Application Notes

DC/DC-Converter

Block Diagrams

Powerline Plus Output Trim Tables

RPRxx-xx24S (all types)

Trim up	1	2	3	4	5	6	7	8	9	10	%
V _{out} =	24,24	24,48	24,72	24,96	25,20	25,44	24,68	25,92	26,16	26,4	Volts
R _U =	270	120	70	45.2	30.1	19.8	12.8	7.52	3.31	0	KOhms
Trim down	1	2	3	4	5	6	7	8	9	10	%
V _{out} =	23,76	23,52	23,28	23,04	22,80	22,56	22,32	22,08	21,84	21,6	Volts
R _D =	270	120	70	45.2	30.1	19.8	12.8	7.52	3.31	0	KOhms

Block Diagrams

Single Output - 3.3V and 5V Outputs

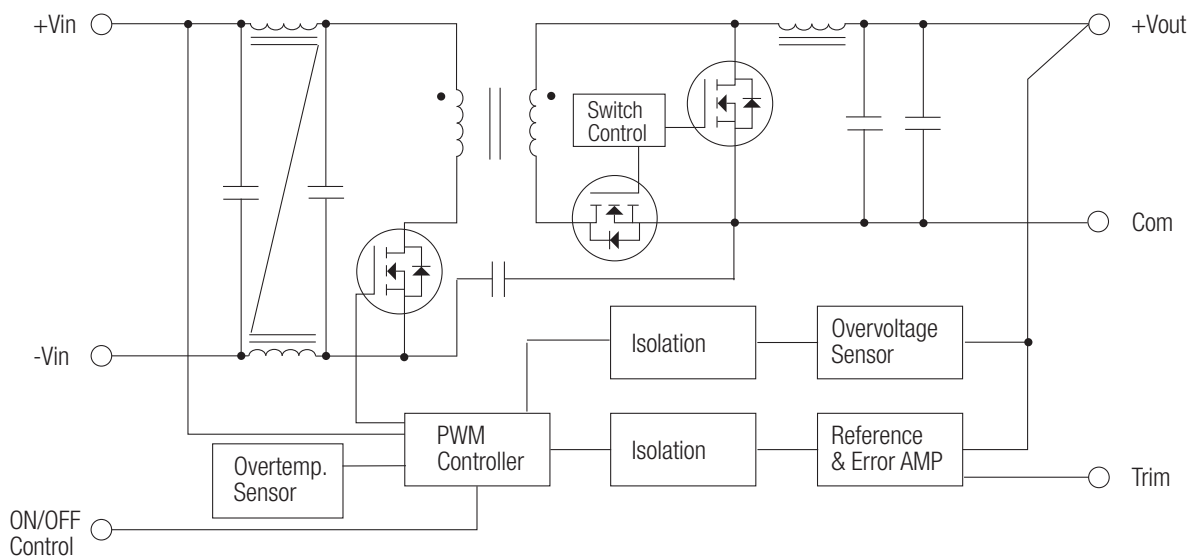

Single Output - all other outputs

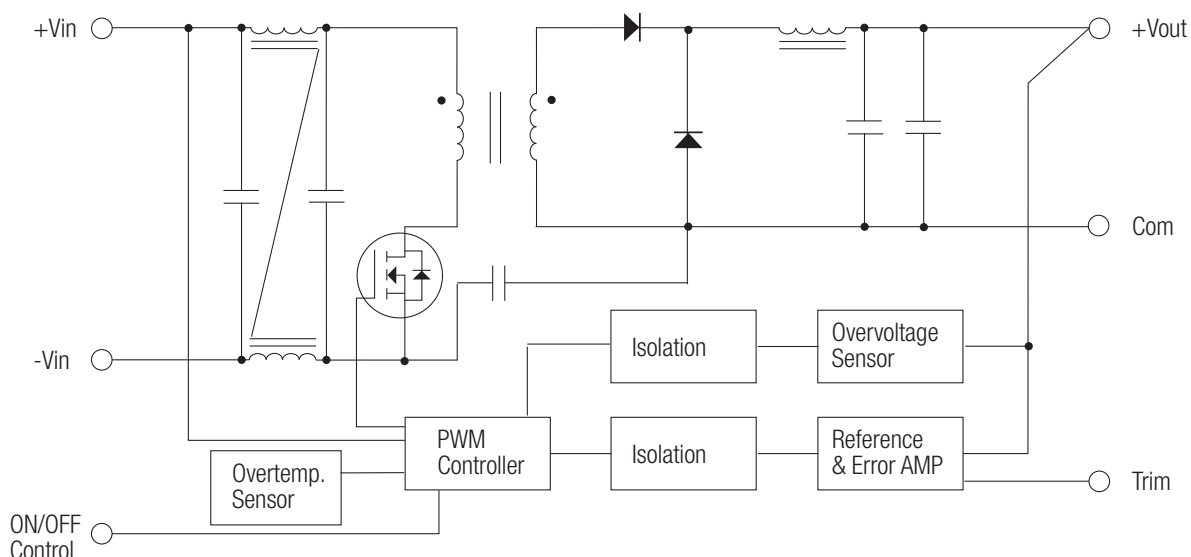

POWERLINE+ Application Notes

DC/DC-Converter

Block Diagrams

Block Diagrams

Dual Output

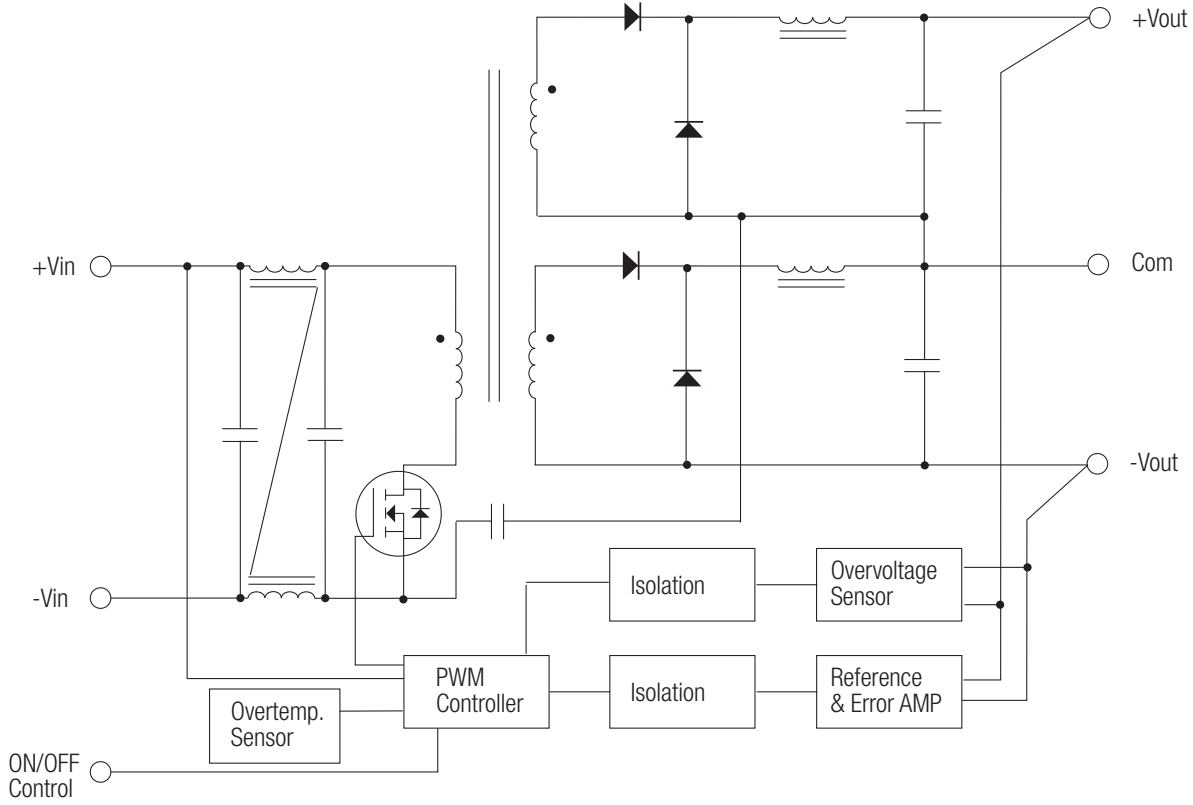

Features

ICE Technology*

- T2 Temperature Range without Derating
- 120°C Maximum Case Temperature
- -45°C Minimum Operating Temperature
- EN 50155 Certified
- EN 50121-3-2 Certified
- CE Marked
- 24, 48 and 110VDC Input Ranges
- Six Sided Shielded Enclosure
- Baseplate Case Style
- Efficiency to >89%
- Low Quiescent Current

Description

The RPR40 series DC/DC converters are designed for railway rolling stock applications. Besides covering all the input voltages from 24VDC up to 110VDC, the converters have a very wide operating temperature range of -45°C to +120°C. The RPR40 is available has a baseplate case for high vibration or bulkhead-mounting applications. It is EN 50155 and EN 50121-3-2 compliant.

Selection Guide 24V, 48V and 110V Input Types

Part Number	Nominal Input VDC	Nom. Input Range VDC	Lockout Voltage VDC	Output Voltage VDC	Output Current mA
RPR40-243.3S-B	24	12-36	8	3.3	12100
RPR40-2405S-B	24	12-36	8	5	8000
RPR40-2412S-B	24	12-36	8	12	3300
RPR40-2415S-B	24	12-36	8	15	2670
RPR40-2424S-B	24	12-36	8	24	1670
RPR40-483.3S-B	48	25-75	17	3.3	12100
RPR40-4805S-B	48	25-75	17	5	8000
RPR40-4812S-B	48	25-75	17	12	3300
RPR40-4815S-B	48	25-75	17	15	2670
RPR40-4824S-B	48	25-75	17	24	1670
RPR40-1103.3S-B	110	40-160	36	3.3	12100
RPR40-11005S-B	110	40-160	36	5	8000
RPR40-11012S-B	110	40-160	36	12	3300
RPR40-11015S-B	110	40-160	36	15	2670
RPR40-11024S-B	110	40-160	36	24	1670
RPR40-2412D-B	24	12-36	8	±12	±1670
RPR40-2415D-B	24	12-36	8	±15	±1330
RPR40-2424D-B	24	12-36	8	±24	±830
RPR40-4812D-B	48	25-75	17	±12	±1670
RPR40-4815D-B	48	25-75	17	±15	±1330
RPR40-4824D-B	48	25-75	17	±24	±830
RPR40-11012D-B	110	40-160	36	±12	±1670
RPR40-11015D-B	110	40-160	36	±15	±1330
RPR40-11024D-B	110	40-160	36	±24	±830

For other CTRL logic or case styles please contact RECOM for availability.

POWERLINE+
Railway-Converter
with 5 year Warranty

RECOM

**40 Watt
Single &
Dual Output**



**EN-50155 Certified
EN-60950 Certified**

RPR40

* ICE Technology

ICE (Innovation in Converter Excellence) uses state-of-the-art techniques to minimise internal power dissipation and to increase the internal temperature limits to extend the ambient operating temperature range to the maximum.

Refer to Application Notes

Railway Input Voltage Requirements

Nominal Input Voltage	EN50155			NF F 01-510			RPR40		
	Input Range	Min. Input (0.1s)	Max Input (1s)	Input Range	Min. Input (0.1s)	Max Input (1s)	Input Range	Min. Input (0.1s)	Max Input (1s)
24V	16.8~30V	14.4V	33.6V	18~34V	12V	40V	12~36V	9V	40V
48V	33.6~60V	28.8V	67.2V				25~75V	18V	80V
72V	50.4~90V	43.2V	100.8V	50~90V	36V	115V	40~160V	36V	176V
96V	67.2~120V	57.6V	134.4V				40~160V	36V	176V
110V	77~137.5V	66V	154V	77~137V	55V	176V	40~160V	36V	176V

Specifications (typical at nominal input and 25°C unless otherwise noted)

Input Voltage Range (continuous)		complies with EN50155 and NFF 01-510 (Un=24V)	12-36VDC
		complies with EN50155 and NFF 01-510 (Un=48V)	25-75VDC
		complies with EN50155 and NFF 01-510 (Un=72V, 96V & 110V)	40-160VDC
Low Transient operating voltage (100ms)		complies with EN50155 and NFF 01-510	Un x 0.5
High Transient operating voltage (1 second)		complies with EN50155 and NFF 01-510	Un x 1.6
Allowed Input Ripple		complies with EN50155	15%
Input Reflected Ripple		nominal Vin and full load	20mA _{p-p}
Supply Interruption (Perf. Criteria B)		according to EN50155, 5.1.1.2	Class S2
		according to EN50155, 5.1.3	Class C2
Start Up Time		nominal Vin and constant resistive load	2ms typ., 5ms max.
Remote ON/OFF ⁽¹⁾		Logic High, Vin=24V, 48V	Open or 3V < Vr < 5,5V
		Logic High, Vin=110V	Open or 8V < Vr < 60V
		Logic Low	Short or 0V < Vr < 1.2V
Remote OFF input current		Nominal input	2mA typ.
Output Voltage Accuracy		50% Load and nominal Vin	±1.5%
Voltage Adjustability		Single Output only	±10%
Minimum Load			0%
Line Regulation		low line, high line at full load	±0.3%
Load Regulation		10% to 100% full load	±0.5%
Cross Regulation (10% <> 100% Load)		Dual Outputs only	3% typ. / 5% max.
Ripple and Noise (20MHz bandwidth limited)		(measured with 1µF capacitor across outputs)	1% Vout typ. / 3% max.
Temperature Coefficient			±0.04%/°C max.
Transient Response		25% load step change	800µs
Over Load Protection		% of full load at nominal Vin	120% typ.
Short Circuit Protection			Hiccup, automatic recovery
Output Over Voltage Protection		Single Output	Converter shutdown if Vout > Vout nominal + 20%
		Dual Output	Converter shutdown if Vout > Vout nominal + 10%
Isolation Voltage		According to EN50155 12.2.9.2	Tested at 1500VAC/1 minute
Isolation Resistance		According to EN50155 12.2.9.1	10MΩ min.
Isolation Capacitance			1500pF max.
Operating Frequency			260kHz ± 40kHz
Operating Temperature Range (Ambient Air, Free Convection)	(T2) (Tx)	complies with EN50155: 4.1.2 and EN50125-1 with derating	-45°C to +85°C -45°C to +100°C
Maximum Case Temperature			+120°C
Over Temperature Protection			Internal thermistor

continued on next page

POWERLINE+

DC/DC-Converter

RPR40-S_D Series

Specifications (typical at nominal input and 25°C unless otherwise noted)

Storage Temperature Range	-55°C to +125°C	
Relative Humidity	5% to 95% RH	
Case Material ⁽²⁾	Aluminium	
Weight	43g	
Packing Quantity	4pcs per Tube	
Safety Standards	CE Marked	certified to EN-60950-1, 1st Edition
Thermal Performance	Cold	-40°C /16 Hours
	Dry Heat, Operating	-40°C/+85°C/ 5 Cycles
complies to EN50155: 12.2.3/4/5	Damp Heat, Cyclic	+25°C/+55°C, 95%RH / 2 x 24 Hours
Vibration, Shock & Bump (complies with EN61373, Category 1 Class B)	Vibration	5-150Hz, X:0.7m/s ² , Y:0.45m/s ² , Z:1m/s ² , 30 mins
	Shock	5g/30ms/18 shocks
Input Filter	Built-in Pi Filter	
Conducted Emissions	EN50121-3-2***	Class A
Radiated Emissions	EN50121-3-2***	Class A
ESD	EN50121-3-2***	Perf. Criteria B
Radiated Immunity	EN50121-3-2***	Perf. Criteria A
Fast Transient	EN50121-3-2***	Perf. Criteria A
Surge	EN50121-3-2***	Perf. Criteria B
Conducted Immunity	EN50121-3-2***	Perf. Criteria A
MTBF calculated according to BELLCORE TR-NWT-000332 Case I: 50% Stress, Temperature at 50°C (Ground Benign)	2195 x 10 ³ hours	

***with filter circuit

RPR40

Typical Control Pin Application Circuit

The CTRL pin can be directly driven with a 24V or 48V signal, or via a transistor with a 5V signal.

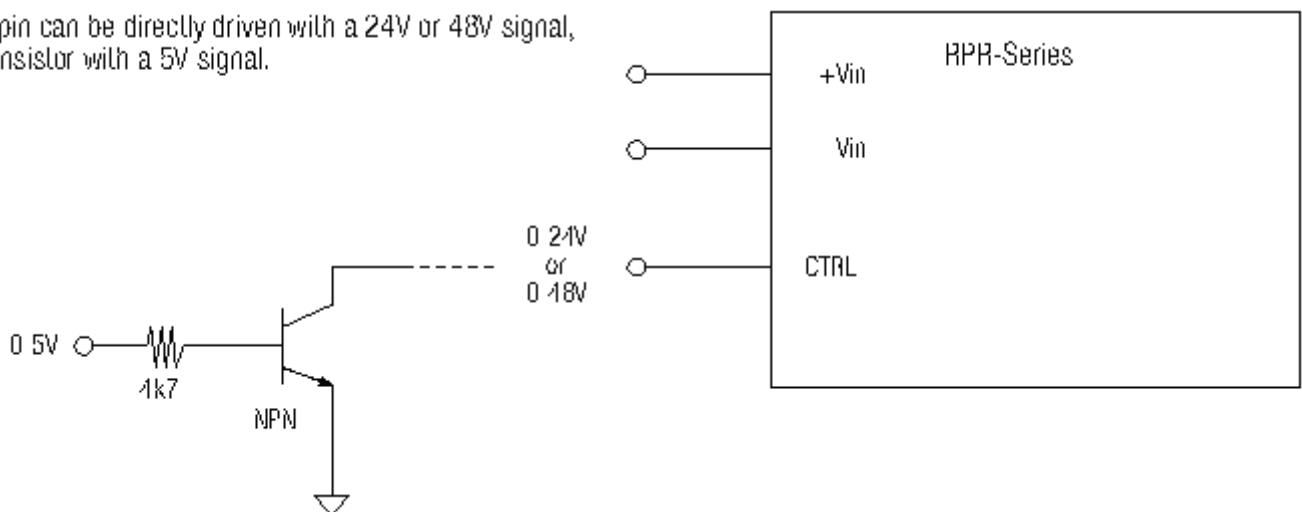

POWERLINE+

DC/DC-Converter

Typical Application Circuit

EN50155 / NF F 01-510 Input Filter

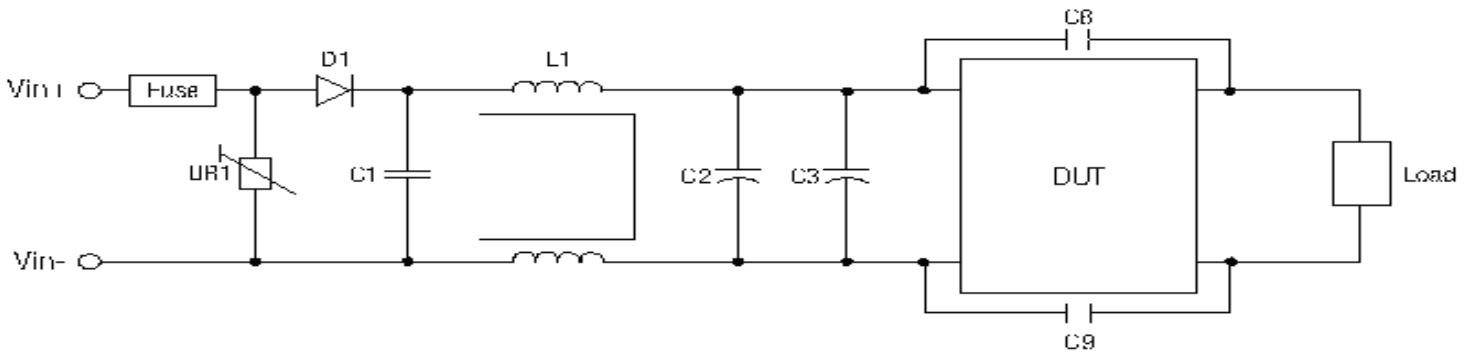

Table

Module	Standard	UR1	D1	C1	L1	C2	C3	C8,C9
24V	EN50155	MOV 14D361K	100V/6A	6,8 μ F/50V	550 μ H \pm 20%	330 μ F/ 50VDC	330 μ F/ 50VDC	4,7nF/3kV
48V	EN50155	MOV 14D361K	200V/3A	220nF/100V	550 μ H \pm 20%	330 μ F/ 100VDC	330 μ F/ 100VDC	4,7nF/3kV
110V	EN50155	MOV 14D361K	300V/3A	470nF/250V	1200 μ H \pm 20%	330 μ F/ 250VDC	330 μ F/ 250VDC	4,7nF/3kV

Notes :

- The ON/OFF pin voltage is referenced to negative input. The pin is pulled high internally. ON/OFF control is standard with positive logic: e.g. RPR20-2405S, RPR20-4805D-B. Positive logic: 0= OFF, 1 = ON. The converter will be ON if the CTRL is left open.
- To ensure a good all-round electrical contact, the baseplate is pressed firmly into place within the aluminium housing. The hydraulic press can leave tooling marks and deformations to both the housing and baseplate. The case is anodised aluminium, so there will be natural variations in the case colour and the aluminium is not scratch resistant. Any resultant marks, scratches and colour variations are cosmetic only and do not affect the operation or performance of the converters.
- The converter is supplied with a protective adhesive tape to keep the top surface clean. The tape is heat resistant and the converter can be soldered into place without removing the tape. The tape should be removed just before final installation.
- The RPR series are optionally available with a ribbed heatsink case style. They will then meet Tx requirements without an external heat-sink. Please contact your RECOM supplier for more information.

Baseplate Case- suggested PCB layout

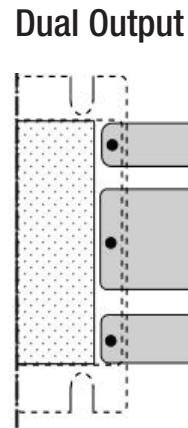
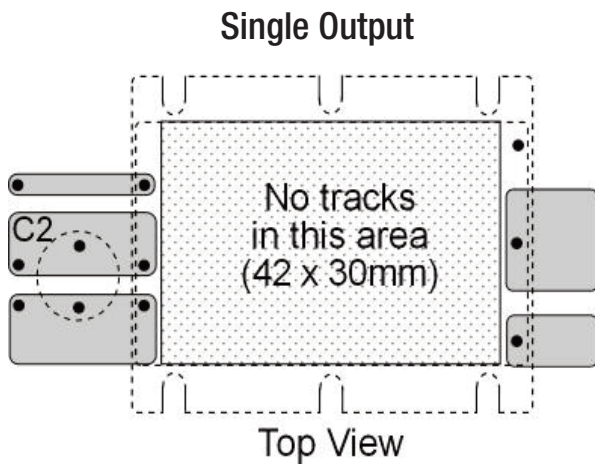

Input Fuse is recommended.
Recommended fuse rating = double maximum input current, time delay type.

To ensure optimum thermal performance, use large areas of copper on the PCB to assist with heat dissipation and mount the converter vertically.

Package Style and Pinning (mm)

Baseplate Case (-B Suffix)

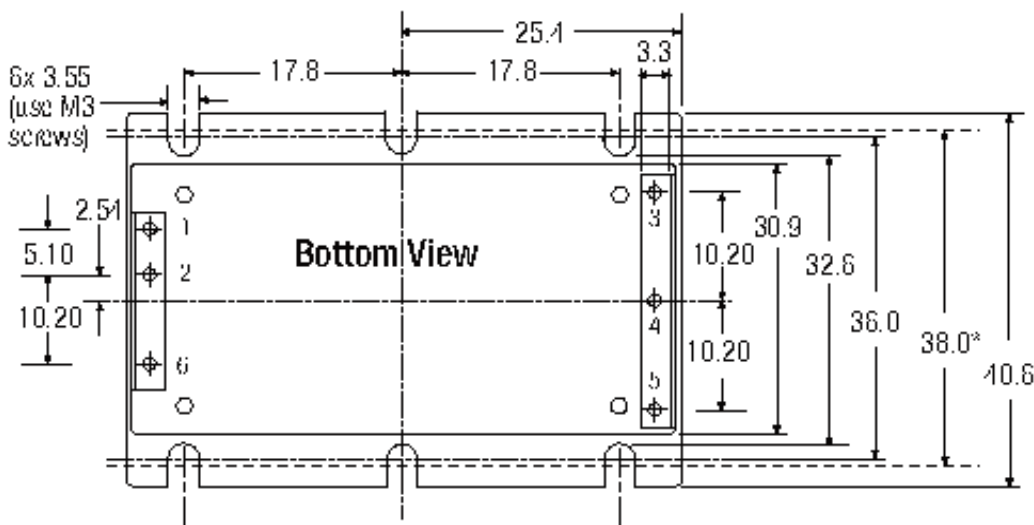
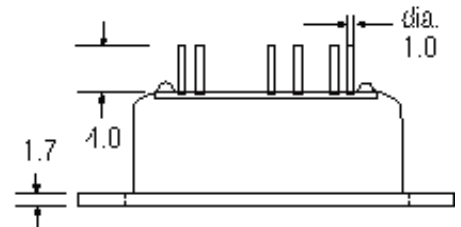
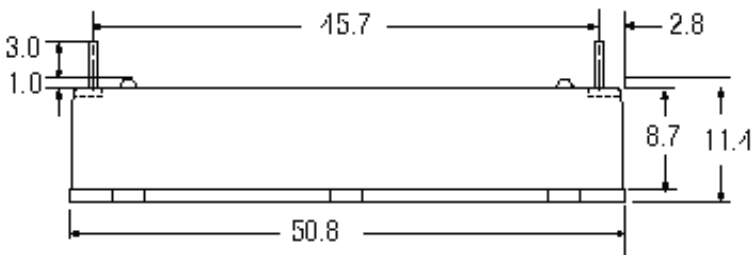

Pin Connections

Pin #	Single	Dual
1	+Vin	+Vin
2	-Vin	-Vin
3	+Vout	+Vout
4	-Vout	Com
5	Trim	-Vout
6	CTRL	CTRL

Pin Pitch Tolerance ± 0.35 mm

*Recommended Fixing Centres

RPR40-S_D Series

POWERLINE+

DC/DC-Converter

Package Style and Pinning (mm)

Baseplate Case Fixing - Mounting onto Heatsink/Bulkhead

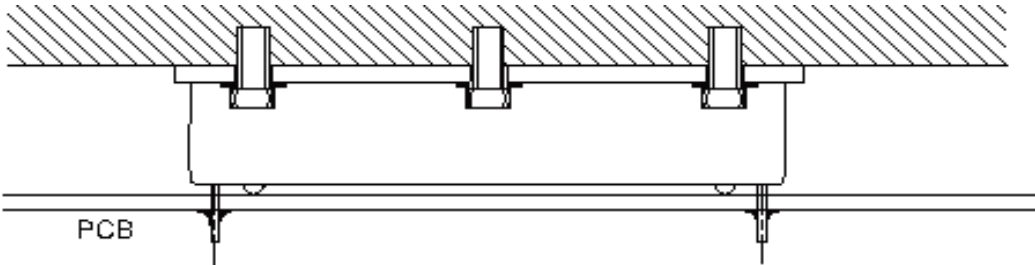

Baseplate Case Fixing - Anti Vibration Mounting onto PCB

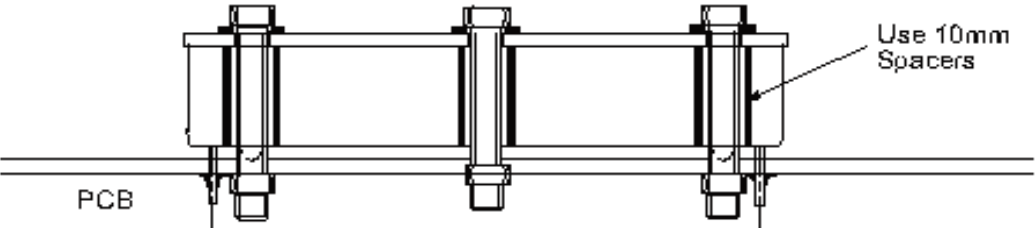

I.C.E Technology

ICE (Innovation in Converter Excellence) Technology uses a combination of techniques to minimise internal heat dissipation and maximise the heat transfer to ambient to create a new converter series which offers high end performance at a price which is significantly lower than conventional specialist converters.

The exact details of this technology must remain secret, but the following brief resume describes the main features of this technological breakthrough:

Minimising internal heat dissipation

The difference between the input power and the output power is the internal power dissipation which generates heat within the converter.

If the converter is inefficient at converting power, then adding external heat sinks, base-plates or fans are remedies that cure the symptoms rather than address the illness.

First and foremost, the converter must have the highest possible efficiency over the entire input voltage range and load conditions. Most power converters are designed to be most efficient at 25°C, full load and nominal input voltage and thus offer a compromise performance when lightly loaded or operated at the maximum ambient temperature.

ICE Technology uses state-of-the-art techniques to improve power conversion efficiency by approximately 2% compared to standard converters. A two per cent improvement may not sound much, but the difference between a converter with 88% efficiency and one with 90% efficiency is a 17% reduction in the dissipated power. In addition, when lightly loaded, the converters enter a power saving mode and draw only a few milliamps from the supply.

Maximising heat transfer

The rate of heat transfer between a hot body and its cooler surroundings is given by Fourier's Law:

$$q = -k \cdot \Delta T$$

where

q = rate of heat transfer

k = thermal conductivity

and ΔT = temperature difference

If k can be made larger, then the rate of heat transfer can still match or exceed the rate of heat generation at lower temperature differences ΔT and the converter will have an extended operating temperature range.

Techniques to improve thermal conductivity

ICE Technology splits the thermal conductivity problem into two areas and attacks each area separately using different techniques.

Firstly, the internal heat transfer to the case is maximised by a combination of novel converter construction and clever thermal design.

ICE converters use a construction where the hottest components (the switching FET, the transformer and the synchronous rectification FETs) are placed closest to the case wall. This method of construction makes the manufacture of the converter more difficult, but this lack of compromise reduces greatly the internal thermal impedance.

Secondly, the rate of transfer of heat to the surroundings is improved by a novel case construction which incorporates a built-in heat sink. The case is also made from thick aircraft grade aluminium rather than thin nickel-plated copper to provide a better thermal junction between the case and the high thermal conductivity silicone potting material used inside the converter.

Maximising high temperature performance

The final technique used in the construction of ICE Technology converters is to use high temperature internal components. The maximum operating temperature of a converter is dependent on the lowest maximum permissible operating temperature of any the components used. If the capacitors are rated up to +85°C and the FETs are rated at +160°C, then the limiting factor is the capacitor temperature of +85°C.

The temperature of the ferrite core used in the transformer is also an important limiting factor. If the transformer core temperature exceeds the Curie temperature of the ferrite, then the transformer rapidly loses performance.

ICE Technology converter uses high temperature grade components to permit a case temperature of +115°C maximum. This allows operation at up to +85°C ambient without the need for fans to blow air over the converter.



Electromagnetic Compatibility

Although high temperature performance is a significant feature of ICE Technology design, it does not end there.

ICE Technology also addresses the need for electromagnetic compatibility by incorporating a built-in EN55022 Class B grade filter inside the converter. The converter has been designed from the ground up to meet EMC requirements rather than a conventional design process where first the converter is optimised for performance and then an external filter is added to combat the conducted interference.

By including the filter on the main PCB of the converter, the track path lengths and impedances between the filter and the noise-generating components are reduced to the minimum and consequently smaller value filter components can be used that fit into the compact case dimensions of the Powerline+ converters without compromising on filter performance.

Safety and Protection

ICE Technology converters are fully protected from output short circuits, overload, output over-voltage and over-temperature. In addition, they feature under-voltage lockout that will automatically disable the converter if the input voltage falls below the minimum level.

The output is current limited which means that temporary overloads can occur without the converter shutting down. When overloaded, the output voltage will decrease to keep the maximum power constant. For the 40W and 50W converters, if the overload is too high, the converter will go into hiccup short circuit protection mode. In this mode, the converter will attempt to reconnect power every 10-20 milliseconds.

Output overvoltage protection is monitored by a separate and independent feedback circuit and an internal thermistor sensor is used to protect the converter against overheating.

POWERLINE+ Application Notes

DC/DC-Converter

Powerline Plus Output Trim Tables



Output Voltage Trimming:

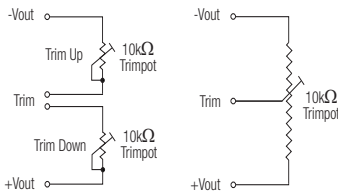

Single output Powerline Plus converters offer the feature of trimming the output voltage over a certain range around the nominal value by using external trim resistors. No general equation can be given for calculating the trim resistors, but the

following trimtables give typical values for choosing these trimming resistors. If voltages between the given trim points are required, extrapolate between the two nearest given values to work out the resistor required or use a variable resistor to set the output voltage.

RPRxx-xx3.3S (all types)

Trim up	1	2	3	4	5	6	7	8	9	10	%
Vout =	3,333	3,366	3,399	3,432	3,465	3,498	3,531	3,564	3,597	3,63	Volts
R _U =	72.8	34.4	21.2	14.4	9.9	7.2	5.3	3.88	2.74	1.84	KOhms
Trim down	1	2	3	4	5	6	7	8	9	10	%
Vout =	3,267	3,234	3,201	3,168	3,135	3,102	3,069	3,036	3,003	2,97	Volts
R _D =	101.3	36.2	21.0	13.65	9.2	6.0	4.12	2.56	1.34	0.87	KOhms

RPRxx-xx05S (all types)

Trim up	1	2	3	4	5	6	7	8	9	10	%
Vout =	5,05	5,1	5,15	5,2	5,25	5,3	5,35	5,4	5,45	5,5	Volts
R _U =	109.7	51	31.2	20.3	14.2	9.87	7.1	5.0	3.38	2.08	KOhms
Trim down	1	2	3	4	5	6	7	8	9	10	%
Vout =	4,95	4,9	4,85	4,8	4,75	4,7	4,65	4,6	4,55	4,5	Volts
R _D =	127.6	55.8	33.0	20.2	14.2	9.46	5.97	3.6	1.77	0.28	KOhms

RPRxx-xx12S (all types)

Trim up	1	2	3	4	5	6	7	8	9	10	%
Vout =	12,12	12,24	12,36	12,48	12,6	12,72	12,84	12,96	13,08	13,2	Volts
R _U =	270	120	70	45.2	30.1	19.8	12.8	7.52	3.31	0	KOhms
Trim down	1	2	3	4	5	6	7	8	9	10	%
Vout =	11,88	11,76	11,64	11,52	11,4	11,28	11,16	11,04	10,92	10,8	Volts
R _D =	270	120	70	45.2	30.1	19.8	12.8	7.52	3.31	0	KOhms

RPRxx-xx15S (all types)

Trim up	1	2	3	4	5	6	7	8	9	10	%
Vout =	15,15	15,3	15,45	15,6	15,75	15,9	16,05	16,2	16,35	16,5	Volts
R _U =	337	150	87	56.2	37.5	24.7	16	9.4	4.16	0	KOhms
Trim down	1	2	3	4	5	6	7	8	9	10	%
Vout =	14,85	14,7	14,55	14,4	14,25	14,1	13,95	13,8	13,65	13,5	Volts
R _D =	337	150	87	56.2	37.5	24.7	16	9.4	4.16	0	KOhms

POWERLINE+ Application Notes

DC/DC-Converter

Block Diagrams

Powerline Plus Output Trim Tables

RPRxx-xx24S (all types)

Trim up	1	2	3	4	5	6	7	8	9	10	%
Vout =	24,24	24,48	24,72	24,96	25,20	25,44	24,68	25,92	26,16	26,4	Volts
R _U =	270	120	70	45.2	30.1	19.8	12.8	7.52	3.31	0	KOhms
Trim down	1	2	3	4	5	6	7	8	9	10	%
Vout =	23,76	23,52	23,28	23,04	22,80	22,56	22,32	22,08	21,84	21,6	Volts
R _D =	270	120	70	45.2	30.1	19.8	12.8	7.52	3.31	0	KOhms

Block Diagrams

Single Output - 3.3V and 5V Outputs

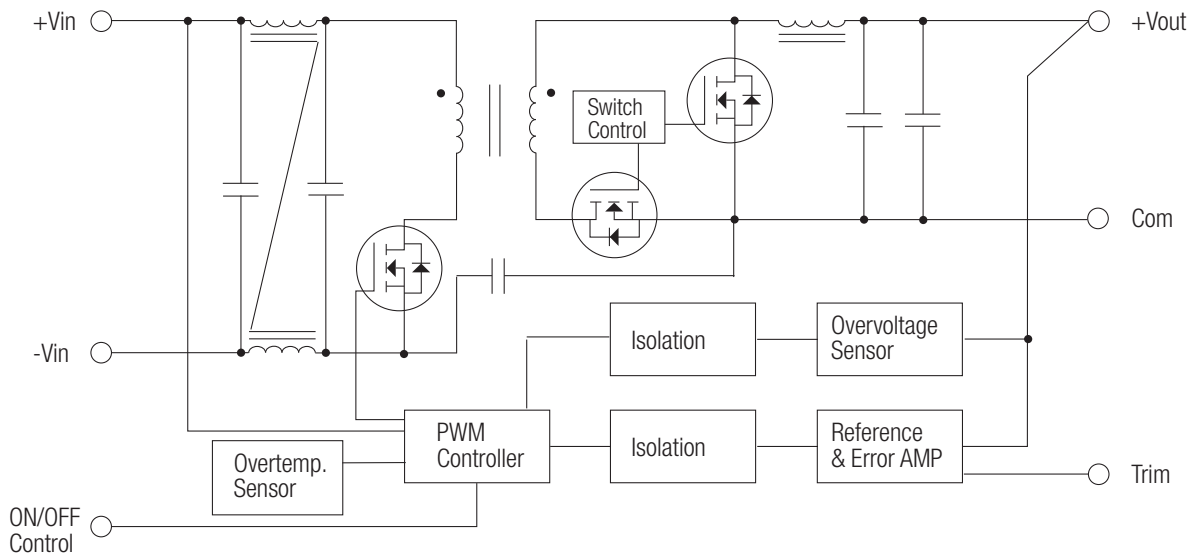

Single Output - all other outputs

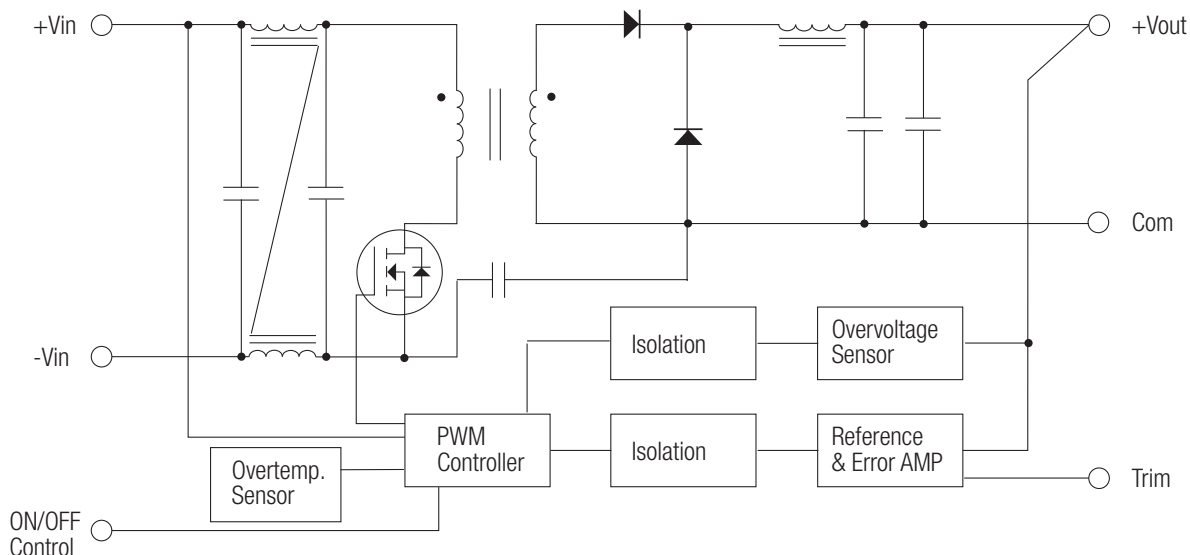

POWERLINE+ Application Notes

DC/DC-Converter

Block Diagrams

Block Diagrams

Dual Output

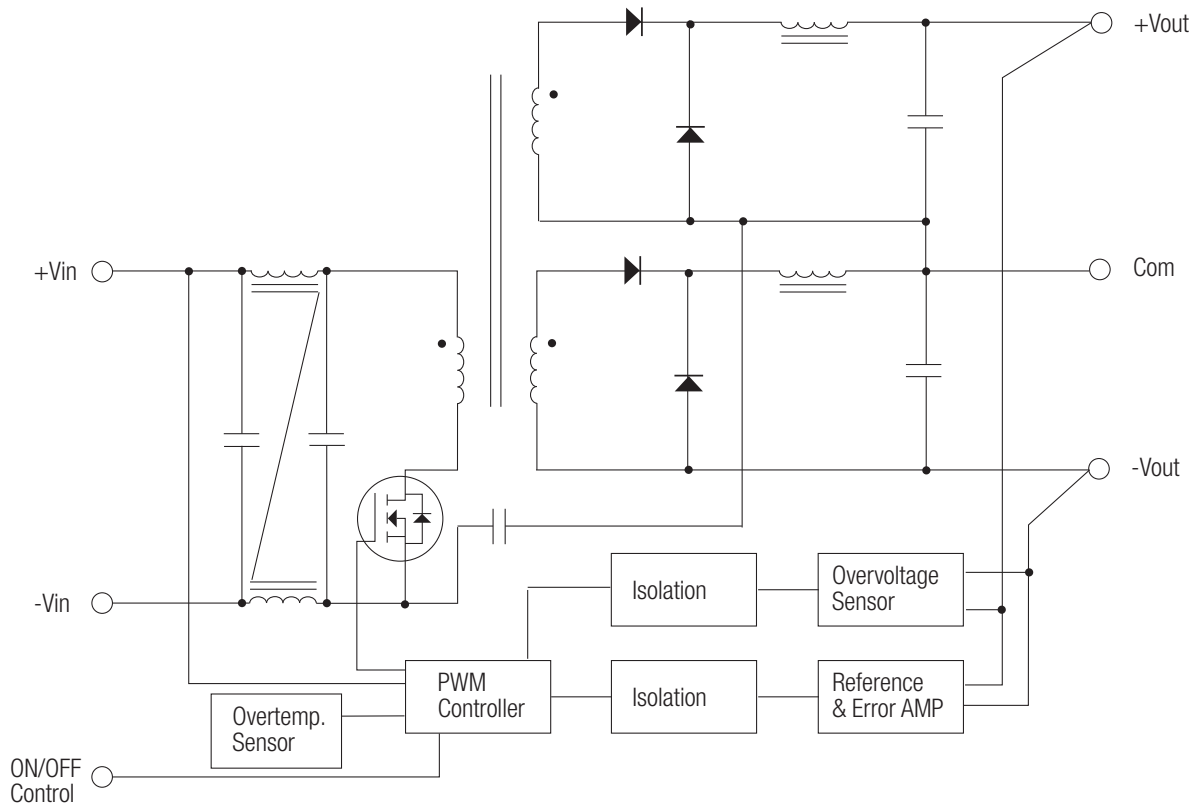

App Notes

Features

ICE Technology*

- T2 Temperature Range without Derating
- 120°C Maximum Case Temperature
- -45°C Minimum Temp.
- EN 50155 Certified
- EN 50121-3-2 Certified
- CE Marked
- 24, 48 and 110VDC Input Ranges
- Six Sided Shielded Enclosure
- Baseplate Case Style
- Efficiency to >89%
- Low Quiescent Current

Description

The RPR50 series DC/DC converters are designed for railway rolling stock applications. Besides covering all the input voltages from 24VDC up to 110VDC, the converters have a very wide operating temperature range of -45°C to +120°C. The RPR50 has a baseplate case for high vibration or bulkhead-mounting applications. It is EN 50155 and EN 50121-3-2 compliant.

Selection Guide 24V, 48V and 110V Input Types

Part Number	Nominal Input VDC	Nom. Input Range VDC	Lockout Voltage VDC	Output Voltage VDC	Output Current mA
RPR50-243.3S-B	24	12-36	8	3.3	15000
RPR50-2405S-B	24	12-36	8	5	10000
RPR50-2412S-B	24	12-36	8	12	4100
RPR50-2415S-B	24	12-36	8	15	3300
RPR50-2424S-B	24	12-36	8	24	2100
RPR50-483.3S-B	48	25-75	17	3.3	15000
RPR50-4805S-B	48	25-75	17	5	10000
RPR50-4812S-B	48	25-75	17	12	4100
RPR50-4815S-B	48	25-75	17	15	3300
RPR50-4824S-B	48	25-75	17	24	2100
RPR50-1103.3S-B	110	40-160	36	3.3	15000
RPR50-11005S-B	110	40-160	36	5	10000
RPR50-11012S-B	110	40-160	36	12	4100
RPR50-11015S-B	110	40-160	36	15	3300
RPR50-11024S-B	110	40-160	36	24	2100
RPR50-2412D-B	24	12-36	8	±12	±2100
RPR50-2415D-B	24	12-36	8	±15	±1650
RPR50-2424D-B	24	12-36	8	±24	±1050
RPR50-4812D-B	48	25-75	17	±12	±2100
RPR50-4815D-B	48	25-75	17	±15	±1650
RPR50-4824D-B	48	25-75	17	±24	±1050
RPR50-11012D-B	110	40-160	36	±12	±2100
RPR50-11015D-B	110	40-160	36	±15	±1650
RPR50-11024D-B	110	40-160	36	±24	±1050

For other CTRL logic or case style options please contact RECOM for availability.

POWERLINE+

Railway-Converter

with 5 year Warranty

RECOM

50 Watt

Single &

Dual Output



EN-50155 Certified
EN-60950 Certified

RPR50

* ICE Technology

ICE (Innovation in Converter Excellence) uses state-of-the-art techniques to minimise internal power dissipation and to increase the internal temperature limits to extend the ambient operating temperature range to the maximum.

Refer to Application Notes

Railway Input Voltage Requirements

Nominal Input Voltage	EN50155			NF F 01-510			RPR50		
	Input Range	Min. Input (0.1s)	Max Input (1s)	Input Range	Min. Input (0.1s)	Max Input (1s)	Input Range	Min. Input (0.1s)	Max Input (1s)
24V	16.8~30V	14.4V	33.6V	18~34V	12V	40V	12~36V	9V	40V
48V	33.6~60V	28.8V	67.2V				25~75V	18V	80V
72V	50.4~90V	43.2V	100.8V	50~90V	36V	115V	40~160V	36V	176V
96V	67.2~120V	57.6V	134.4V				40~160V	36V	176V
110V	77~137.5V	66V	154V	77~137V	55V	176V	40~160V	36V	176V

Specifications (typical at nominal input and 25°C unless otherwise noted)

Input Voltage Range (continuous)		complies with EN50155 and NFF 01-510 (Un=24V)	12-36VDC
		complies with EN50155 and NFF 01-510 (Un=48V)	25-75VDC
		complies with EN50155 and NFF 01-510 (Un=72V, 96V & 110V)	40-160VDC
Low Transient operating voltage (100ms)		complies with EN50155 and NFF 01-510	Un x 0.5
High Transient operating voltage (1 second)		complies with EN50155 and NFF 01-510	Un x 1.6
Allowed Input Ripple		complies with EN50155	15%
Input Reflected Ripple		nominal Vin and full load	20mA _{p-p}
Supply Interruption (Perf. Criteria B)		according to EN50155, 5.1.1.2	Class S2
		according to EN50155, 5.1.3	Class C2
Start Up Time		nominal Vin and constant resistive load	2ms typ., 5ms max.
Remote ON/OFF ⁽¹⁾		Logic High, Vin=24V, 48V	Open or 3V < Vr < 5,5V
		Logic High, Vin=110V	Open or 8V < Vr < 60V
		Logic Low	Short or 0V < Vr < 1.2V
Remote OFF input current		Nominal input	2mA typ.
Output Voltage Accuracy		50% Load and nominal Vin	±1.5%
Voltage Adjustability		Single Output only	±10%
Minimum Load			0%
Line Regulation		low line, high line at full load	±0.3%
Load Regulation		10% to 100% full load	±0.5%
Cross Regulation (10% <> 100% Load)		Dual Outputs only	3% typ. / 5% max.
Ripple and Noise (20MHz bandwidth limited)		(measured with 1µF capacitor across outputs)	1% Vout typ. / 3% max.
Temperature Coefficient			±0.04%/°C max.
Transient Response		25% load step change	800µs
Over Load Protection		% of full load at nominal Vin	120% typ.
Short Circuit Protection			Hiccup, automatic recovery
Output Over Voltage Protection		Single Output	Converter shutdown if Vout > Vout nominal + 20%
		Dual Output	Converter shutdown if Vout > Vout nominal + 10%
Isolation Voltage		According to EN50155 12.2.9.2	Tested at 1500VAC/1 minute
Isolation Resistance		According to EN50155 12.2.9.1	10MΩ min.
Isolation Capacitance			1500pF max.
Operating Frequency			260kHz ± 40kHz
Operating Temperature Range (Ambient Air, Free Convection)	(T2) (Tx)	complies with EN50155: 4.1.2 and EN50125-1 with derating	-45°C to +85°C -45°C to +100°C
Maximum Case Temperature			+120°C
Over Temperature Protection			Internal thermistor

continued on next page

POWERLINE+

DC/DC-Converter

RPR50-S_D Series

Specifications (typical at nominal input and 25°C unless otherwise noted)

Storage Temperature Range	-55°C to +125°C	
Relative Humidity	5% to 95% RH	
Case Material ⁽²⁾	Aluminium	
Weight	43g	
Packing Quantity	4pcs per Tube	
Safety Standards	CE Marked	certified to EN-60950-1, 1st Edition
Thermal Performance	Cold	-40°C /16 Hours
	Dry Heat, Operating	-40°C/+85°C/ 5 Cycles
complies to EN50155: 12.2.3/4/5	Damp Heat, Cyclic	+25°C/+55°C, 95%RH / 2 x 24 Hours
Vibration, Shock & Bump (complies with EN61373, Category 1 Class B)	Vibration	5-150Hz, X:0.7m/s ² , Y:0.45m/s ² , Z:1m/s ² , 30 mins
	Shock	5g/30ms/18 shocks
Input Filter	Built-in Pi Filter	
Conducted Emissions	EN50121-3-2***	Class A
Radiated Emissions	EN50121-3-2***	Class A
ESD	EN50121-3-2***	Perf. Criteria B
Radiated Immunity	EN50121-3-2***	Perf. Criteria A
Fast Transient	EN50121-3-2***	Perf. Criteria A
Surge	EN50121-3-2***	Perf. Criteria B
Conducted Immunity	EN50121-3-2***	Perf. Criteria A
MTBF calculated according to BELLCORE TR-NWT-000332 Case I: 50% Stress, Temperature at 50°C (Ground Benign)	2195 x 10 ³ hours	

***with filter circuit

Typical Control Pin Application Circuit

The CTRL pin can be directly driven with a 24V or 48V signal, or via a transistor with a 5V signal.

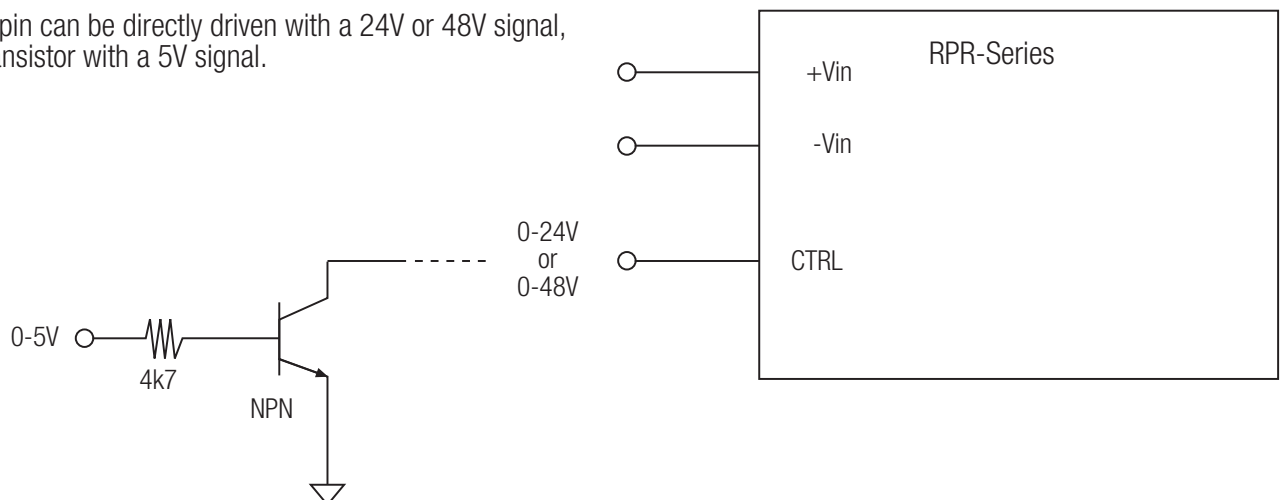

POWERLINE+

DC/DC-Converter

Typical Application Circuit

EN50155 / NF F 01-510 Input Filter

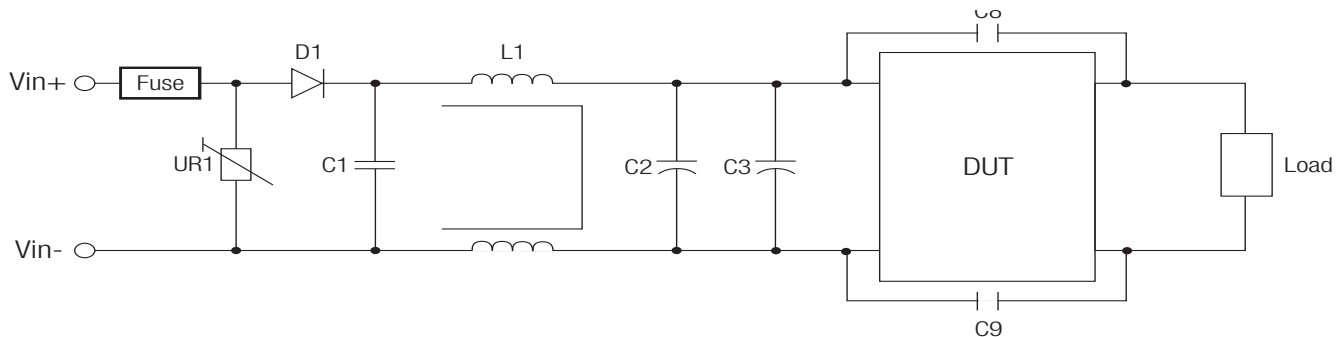

Table

Module	Standard	UR1	D1	C1	L1	C2	C3	C8,C9
24V	EN50155	MOV 14D361K	100V/6A	6,8 μ F/50V	550 μ H \pm 20%	330 μ F/ 50VDC	330 μ F/ 50VDC	4,7nF/3kV
48V	EN50155	MOV 14D361K	200V/3A	220nF/100V	550 μ H \pm 20%	330 μ F/ 100VDC	330 μ F/ 100VDC	4,7nF/3kV
110V	EN50155	MOV 14D361K	300V/3A	470nF/250V	1200 μ H \pm 20%	330 μ F/ 250VDC	330 μ F/ 250VDC	4,7nF/3kV

Notes :

- The ON/OFF pin voltage is referenced to negative input. The pin is pulled high internally. ON/OFF control is standard with positive logic: e.g. RPR20-2405S, RPR20-4805D-B. Positive logic: 0= OFF, 1 = ON. The converter will be ON if the CTRL is left open.
- To ensure a good all-round electrical contact, the baseplate is pressed firmly into place within the aluminium housing. The hydraulic press can leave tooling marks and deformations to both the housing and baseplate. The case is anodised aluminium, so there will be natural variations in the case colour and the aluminium is not scratch resistant. Any resultant marks, scratches and colour variations are cosmetic only and do not affect the operation or performance of the converters.
- The converter is supplied with a protective adhesive tape to keep the top surface clean. The tape is heat resistant and the converter can be soldered into place without removing the tape. The tape should be removed just before final installation.
- The RPR series are optionally available with a ribbed heatsink case style. They will then meet Tx requirements without an external heat-sink. Please contact your RECOM supplier for more information.

POWERLINE+

DC/DC-Converter

RPR50-S_D Series

Recommended PCB Layout

Baseplate Case- suggested PCB layout

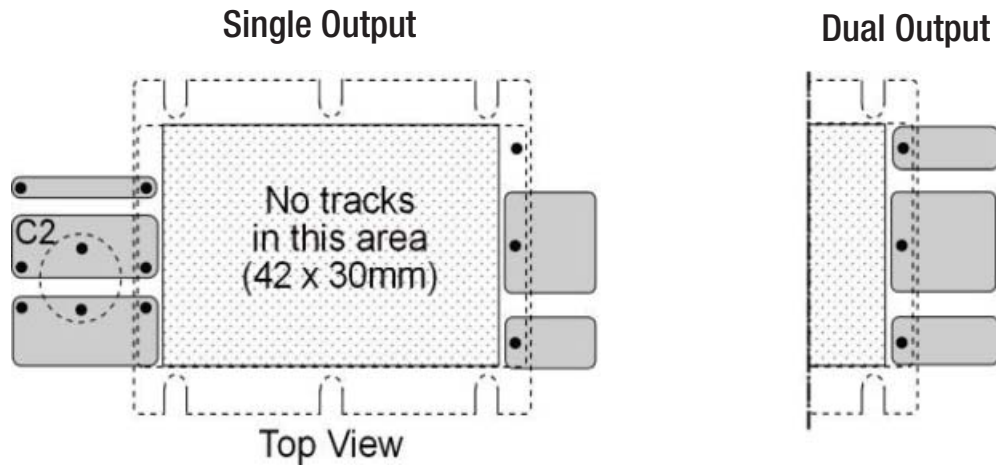

Input Fuse is recommended.
Recommended fuse rating = double maximum input current, time delay type.

To ensure optimum thermal performance, use large areas of copper on the PCB to assist with heat dissipation and mount the converter vertically.

Package Style and Pinning (mm)

Baseplate Case (-B Suffix)

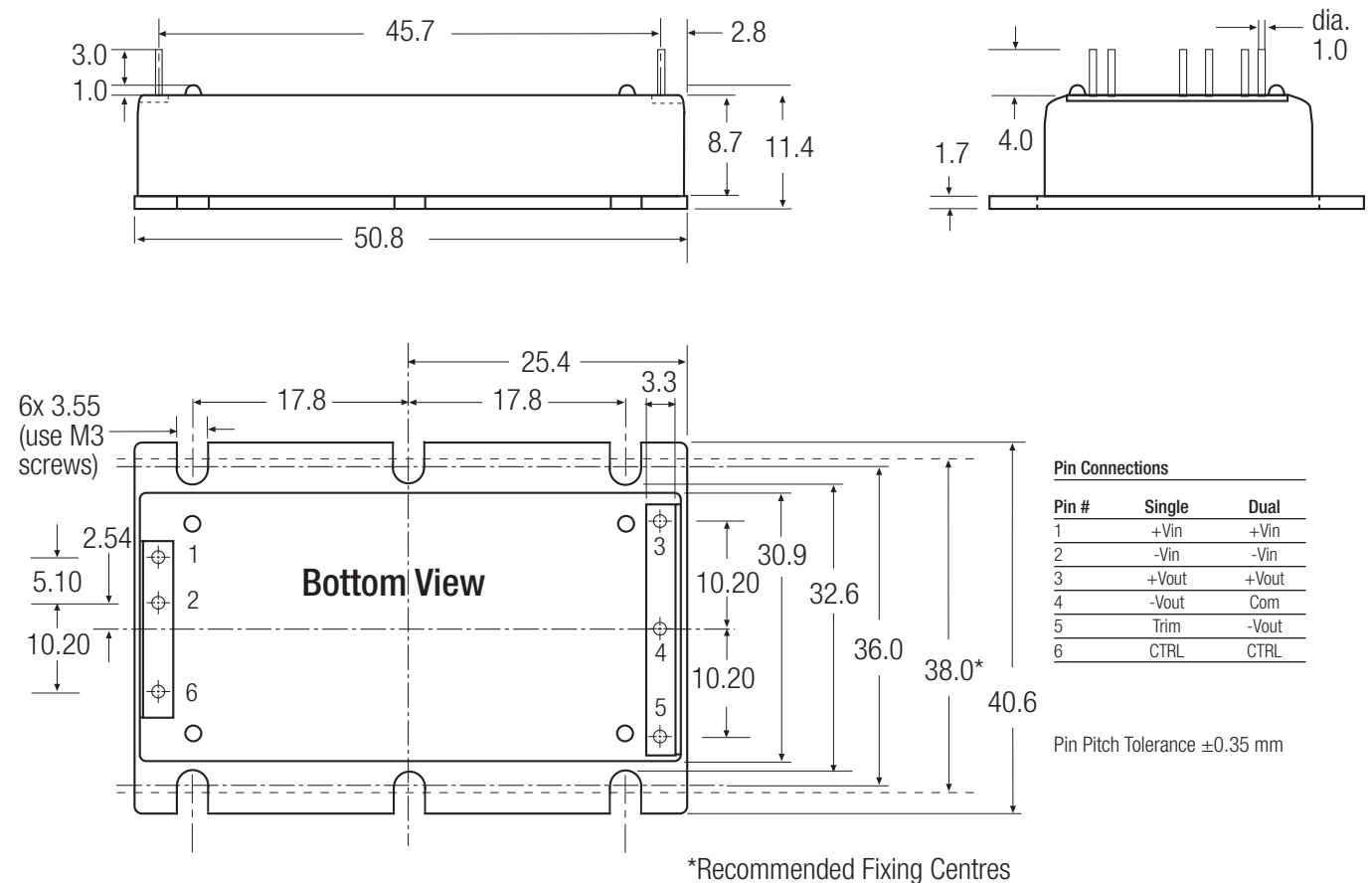

RPR50

POWERLINE+

DC/DC-Converter

Package Style and Pinning (mm)

RPR50-S_D Series

Baseplate Case Fixing - Mounting onto Heatsink/Bulkhead

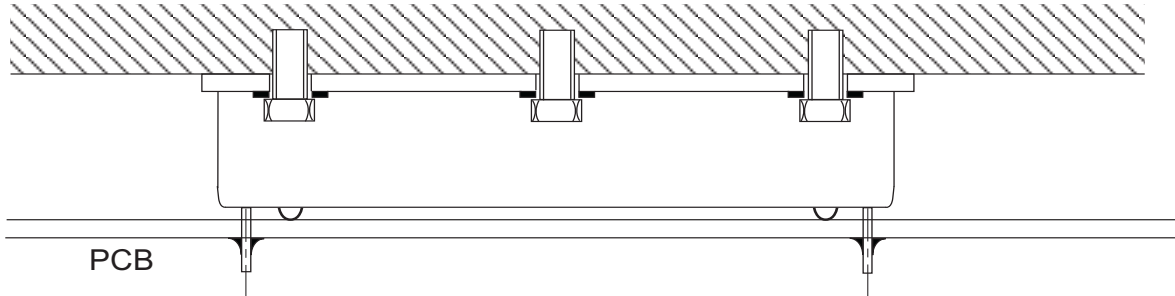

Baseplate Case Fixing - Anti Vibration Mounting onto PCB

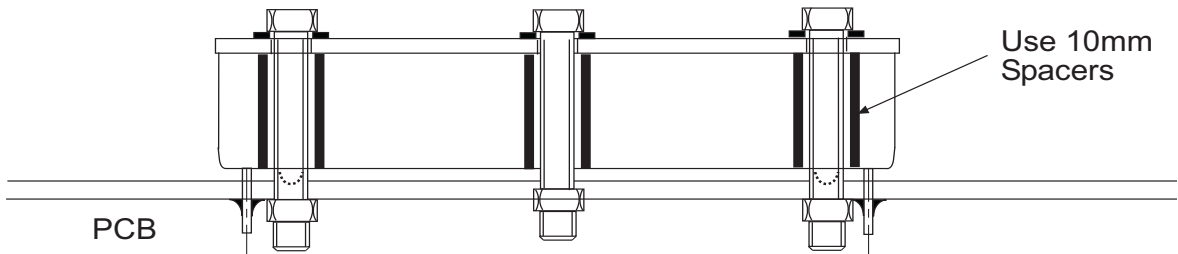

I.C.E Technology

ICE (Innovation in Converter Excellence) Technology uses a combination of techniques to minimise internal heat dissipation and maximise the heat transfer to ambient to create a new converter series which offers high end performance at a price which is significantly lower than conventional specialist converters.

The exact details of this technology must remain secret, but the following brief resume describes the main features of this technological breakthrough:

Minimising internal heat dissipation

The difference between the input power and the output power is the internal power dissipation which generates heat within the converter.

If the converter is inefficient at converting power, then adding external heat sinks, base-plates or fans are remedies that cure the symptoms rather than address the illness.

First and foremost, the converter must have the highest possible efficiency over the entire input voltage range and load conditions. Most power converters are designed to be most efficient at 25°C, full load and nominal input voltage and thus offer a compromise performance when lightly loaded or operated at the maximum ambient temperature.

ICE Technology uses state-of-the-art techniques to improve power conversion efficiency by approximately 2% compared to standard converters. A two per cent improvement may not sound much, but the difference between a converter with 88% efficiency and one with 90% efficiency is a 17% reduction in the dissipated power. In addition, when lightly loaded, the converters enter a power saving mode and draw only a few milliamps from the supply.

Maximising heat transfer

The rate of heat transfer between a hot body and its cooler surroundings is given by Fourier's Law:

$$q = -k \cdot \Delta T$$

where

q = rate of heat transfer

k = thermal conductivity

and ΔT = temperature difference

If k can be made larger, then the rate of heat transfer can still match or exceed the rate of heat generation at lower temperature differences ΔT and the converter will have an extended operating temperature range.

Techniques to improve thermal conductivity

ICE Technology splits the thermal conductivity problem into two areas and attacks each area separately using different techniques.

Firstly, the internal heat transfer to the case is maximised by a combination of novel converter construction and clever thermal design.

ICE converters use a construction where the hottest components (the switching FET, the transformer and the synchronous rectification FETs) are placed closest to the case wall. This method of construction makes the manufacture of the converter more difficult, but this lack of compromise reduces greatly the internal thermal impedance.

Secondly, the rate of transfer of heat to the surroundings is improved by a novel case construction which incorporates a built-in heat sink. The case is also made from thick aircraft grade aluminium rather than thin nickel-plated copper to provide a better thermal junction between the case and the high thermal conductivity silicone potting material used inside the converter.

Maximising high temperature performance

The final technique used in the construction of ICE Technology converters is to use high temperature internal components. The maximum operating temperature of a converter is dependent on the lowest maximum permissible operating temperature of any the components used. If the capacitors are rated up to +85°C and the FETs are rated at +160°C, then the limiting factor is the capacitor temperature of +85°C.

The temperature of the ferrite core used in the transformer is also an important limiting factor. If the transformer core temperature exceeds the Curie temperature of the ferrite, then the transformer rapidly loses performance.

ICE Technology converter uses high temperature grade components to permit a case temperature of +115°C maximum. This allows operation at up to +85°C ambient without the need for fans to blow air over the converter.



Electromagnetic Compatibility

Although high temperature performance is a significant feature of ICE Technology design, it does not end there.

ICE Technology also addresses the need for electromagnetic compatibility by incorporating a built-in EN55022 Class B grade filter inside the converter. The converter has been designed from the ground up to meet EMC requirements rather than a conventional design process where first the converter is optimised for performance and then an external filter is added to combat the conducted interference.

By including the filter on the main PCB of the converter, the track path lengths and impedances between the filter and the noise-generating components are reduced to the minimum and consequently smaller value filter components can be used that fit into the compact case dimensions of the Powerline+ converters without compromising on filter performance.

Safety and Protection

ICE Technology converters are fully protected from output short circuits, overload, output over-voltage and over-temperature. In addition, they feature under-voltage lockout that will automatically disable the converter if the input voltage falls below the minimum level.

The output is current limited which means that temporary overloads can occur without the converter shutting down. When overloaded, the output voltage will decrease to keep the maximum power constant. For the 40W and 50W converters, if the overload is too high, the converter will go into hiccup short circuit protection mode. In this mode, the converter will attempt to reconnect power every 10-20 milliseconds.

Output overvoltage protection is monitored by a separate and independent feedback circuit and an internal thermistor sensor is used to protect the converter against overheating.

POWERLINE+ Application Notes

DC/DC-Converter

Powerline Plus Output Trim Tables



Output Voltage Trimming:

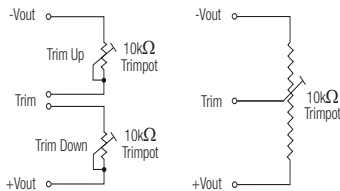

Single output Powerline Plus converters offer the feature of trimming the output voltage over a certain range around the nominal value by using external trim resistors. No general equation can be given for calculating the trim resistors, but the

following trimtables give typical values for choosing these trimming resistors. If voltages between the given trim points are required, extrapolate between the two nearest given values to work out the resistor required or use a variable resistor to set the output voltage.

RPRxx-xx3.3S (all types)

Trim up	1	2	3	4	5	6	7	8	9	10	%
Vout =	3,333	3,366	3,399	3,432	3,465	3,498	3,531	3,564	3,597	3,63	Volts
R _U =	72.8	34.4	21.2	14.4	9.9	7.2	5.3	3.88	2.74	1.84	KOhms
Trim down	1	2	3	4	5	6	7	8	9	10	%
Vout =	3,267	3,234	3,201	3,168	3,135	3,102	3,069	3,036	3,003	2,97	Volts
R _D =	101.3	36.2	21.0	13.65	9.2	6.0	4.12	2.56	1.34	0.87	KOhms

RPRxx-xx05S (all types)

Trim up	1	2	3	4	5	6	7	8	9	10	%
Vout =	5,05	5,1	5,15	5,2	5,25	5,3	5,35	5,4	5,45	5,5	Volts
R _U =	109.7	51	31.2	20.3	14.2	9.87	7.1	5.0	3.38	2.08	KOhms
Trim down	1	2	3	4	5	6	7	8	9	10	%
Vout =	4,95	4,9	4,85	4,8	4,75	4,7	4,65	4,6	4,55	4,5	Volts
R _D =	127.6	55.8	33.0	20.2	14.2	9.46	5.97	3.6	1.77	0.28	KOhms

RPRxx-xx12S (all types)

Trim up	1	2	3	4	5	6	7	8	9	10	%
Vout =	12,12	12,24	12,36	12,48	12,6	12,72	12,84	12,96	13,08	13,2	Volts
R _U =	270	120	70	45.2	30.1	19.8	12.8	7.52	3.31	0	KOhms
Trim down	1	2	3	4	5	6	7	8	9	10	%
Vout =	11,88	11,76	11,64	11,52	11,4	11,28	11,16	11,04	10,92	10,8	Volts
R _D =	270	120	70	45.2	30.1	19.8	12.8	7.52	3.31	0	KOhms

RPRxx-xx15S (all types)

Trim up	1	2	3	4	5	6	7	8	9	10	%
Vout =	15,15	15,3	15,45	15,6	15,75	15,9	16,05	16,2	16,35	16,5	Volts
R _U =	337	150	87	56.2	37.5	24.7	16	9.4	4.16	0	KOhms
Trim down	1	2	3	4	5	6	7	8	9	10	%
Vout =	14,85	14,7	14,55	14,4	14,25	14,1	13,95	13,8	13,65	13,5	Volts
R _D =	337	150	87	56.2	37.5	24.7	16	9.4	4.16	0	KOhms

POWERLINE+ Application Notes

DC/DC-Converter

Block Diagrams

Powerline Plus Output Trim Tables

RPRxx-xx24S (all types)

Trim up	1	2	3	4	5	6	7	8	9	10	%
V _{out} =	24,24	24,48	24,72	24,96	25,20	25,44	24,68	25,92	26,16	26,4	Volts
R _U =	270	120	70	45.2	30.1	19.8	12.8	7.52	3.31	0	KOhms
Trim down	1	2	3	4	5	6	7	8	9	10	%
V _{out} =	23,76	23,52	23,28	23,04	22,80	22,56	22,32	22,08	21,84	21,6	Volts
R _D =	270	120	70	45.2	30.1	19.8	12.8	7.52	3.31	0	KOhms

Block Diagrams

Single Output - 3.3V and 5V Outputs

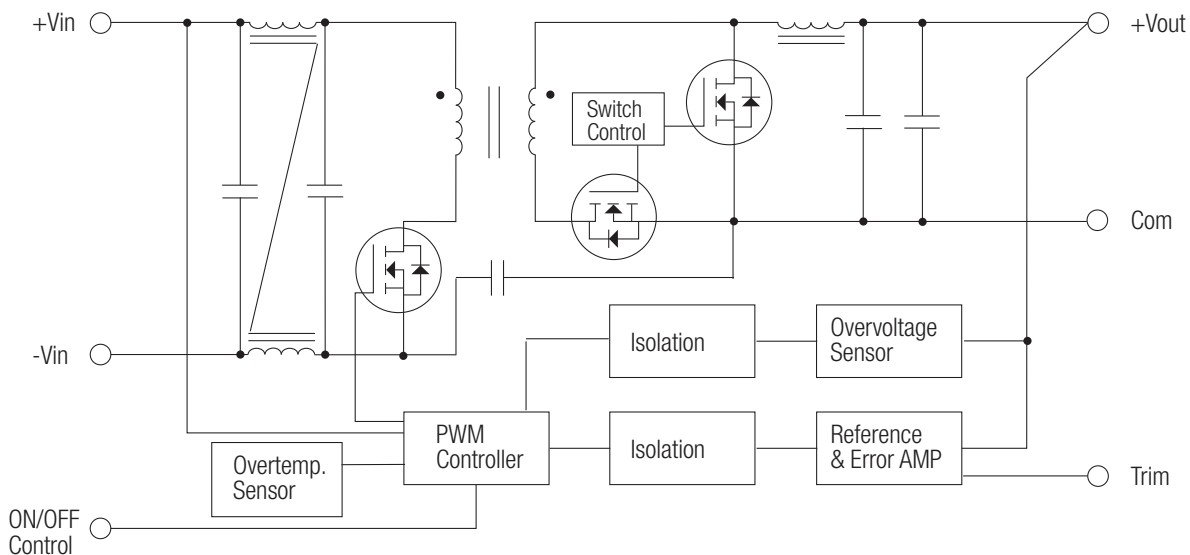

Single Output - all other outputs

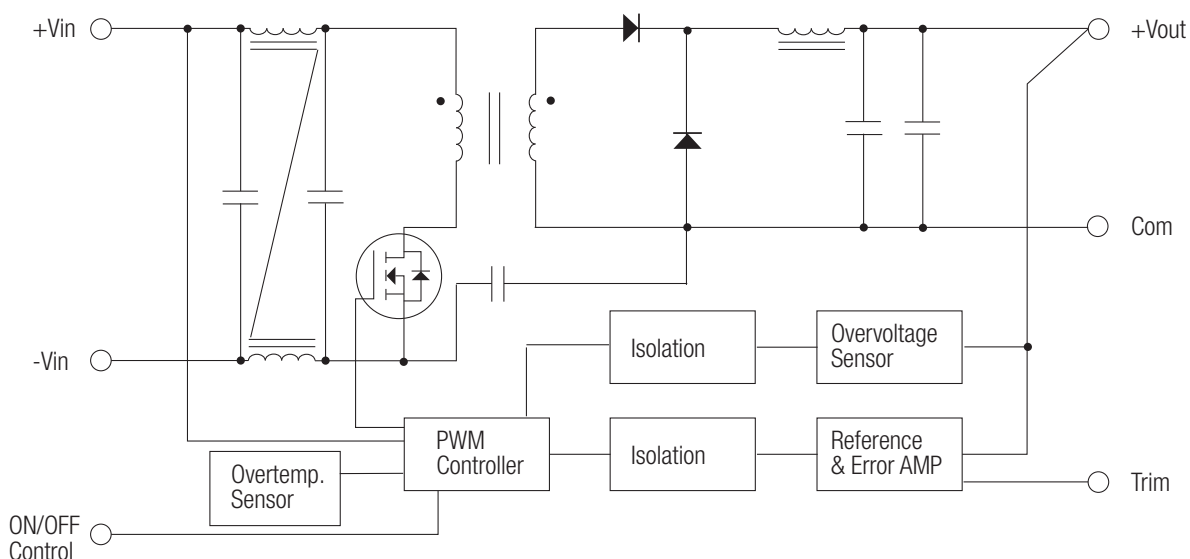

POWERLINE+ Application Notes

DC/DC-Converter

Block Diagrams

Block Diagrams

Dual Output

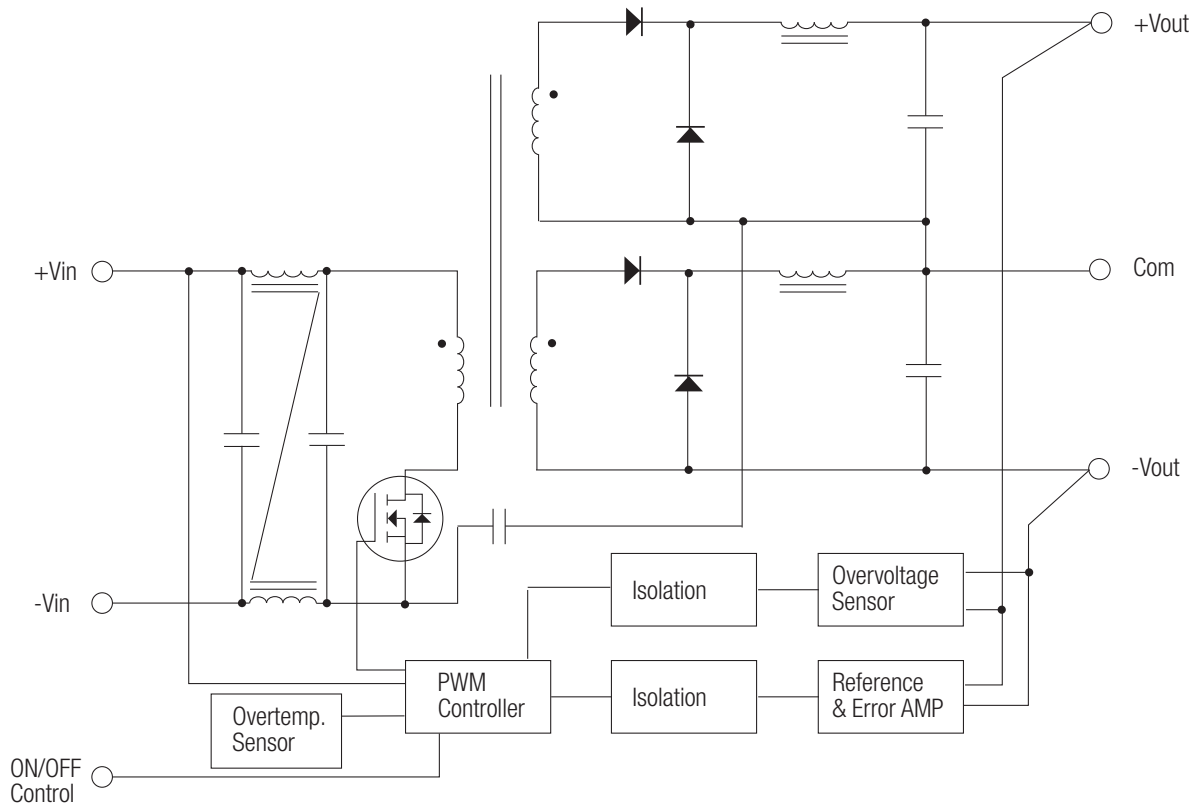

POWERLINE PLUS - CONTENTS

The POWERLINE PLUS uses ICE Technology. A combination of techniques to minimise internal heat dissipation and maximise the heat transfer to ambient to create a new converter series which offers high end performance at a price which is significantly lower than conventional specialist converters. RECOM - Green high-efficiency power solutions. SAVE ENERGY. NOW.



Introduction

The RPP series 2:1 and 4:1 input range DC/DC converters are ideal for high end industrial applications and COTS (Commercial Off-The-Shelf) Military applications where a high ambient operating temperature converter is required.

The converters series feature ICE Technology, a revolutionary method of extending the temperature range without increasing the converter dimensions over standard converters. The built-in aluminium heat sink ensures optimum heat transfer to ambient

Although the case size is compact, the converters contain a built-in EN55022 Class B / FCC Level B filter without the need for any external components.

All RPP series converters are fully protected with undervoltage lockout protection, overload, overcurrent and overvoltage protection, short circuit current limiting and overtemperature shutdown.

In addition, the converters have a quiescent current that is an order of magnitude lower than equivalent power converters.

Regulated DC/DC Converters

Series (**)	Isolation (kVDC)	Power (Watts)	Input Voltages (VDC)	Output Voltages (VDC)	Case Options	Outputs	Page No.
RPP20	2	20	9-18, 18-36, 36-75	3.3, 5, 12, 15, 24 ±12, ±15, ±24	Ribbed & Baseplate	Single and Dual	PP1
RPP20 (W)	2	20	9-36, 18-75	3.3, 5, 12, 15, 24 ±12, ±15, ±24	Ribbed & Baseplate	Single and Dual	PP7
RPP30	2	30	9-18, 18-36, 36-75	3.3, 5, 12, 15, 24 ±12, ±15, ±24	Ribbed & Baseplate	Single and Dual	PP13
RPP30 (W)	2	30	10-40, 18-75	3.3, 5, 12, 15, 24 ±12, ±15, ±24	Ribbed & Baseplate	Single and Dual	PP19
RPP40	2	40	10-40, 18-75	3.3, 5, 12, 15, 24 ±12, ±15, ±24	Ribbed & Baseplate	Single and Dual	PP25
RPP40 (W)	2	40	10-40, 18-75	3.3, 5, 12, 15, 24 ±12, ±15, ±24	Ribbed & Baseplate	Single and Dual	PP31
RPP50	2	50	18-36, 36-75	3.3, 5, 12, 15, 24	Ribbed & Baseplate	Single	PP37
App Notes							PP43

Features

ICE Technology*

- +115°C Maximum Case Temperature
- -40°C Minimum Temp.
- Built-in FCC/EN55022 Class B Filter
- 2:1 Input Voltage Range
- Six Sided Shielded Enclosure
- Ribbed or Baseplate Case Styles
- Min. Efficiency 87%
- 2kVDC Isolation
- Low Quiescent Current

Description

The RPP20 series 2:1 input range DC/DC converters are ideal for high end industrial applications and COTS Military applications where a very wide operating temperature range of -40°C to +115°C is required. Although the case size is very compact, the converter contains a built-in filter EN55022 Class B / FCC Level B without the need for any external components. The RPP20 is available in two case styles: the ribbed case for active cooling and the baseplate case for high vibration, bulkhead-mounting or for passive cooling applications. They are UL-60950-1 certified.

Selection Guide 12V, 24V and 48V Input Types

Part Number	Input Range VDC	Output Voltage VDC	Output Current mA	Efficiency ⁽²⁾ (Typ.)
RPP20-123.3S**	9-18	3.3	6000	88%
RPP20-1205S**	9-18	5	4000	89%
RPP20-1212S**	9-18	12	1666	88%
RPP20-1215S**	9-18	15	1333	88%
RPP20-1224S**	9-18	24	830	88%
RPP20-243.3S**	18-36	3.3	6000	88%
RPP20-2405S**	18-36	5	4000	89%
RPP20-2412S**	18-36	12	1666	88%
RPP20-2415S**	18-36	15	1333	89%
RPP20-2424S**	18-36	24	830	89%
RPP20-483.3S**	36-75	3.3	6000	88%
RPP20-4805S**	36-75	5	4000	89%
RPP20-4812S**	36-75	12	1666	89%
RPP20-4815S**	36-75	15	1333	88%
RPP20-4824S**	36-75	24	830	88%
RPP20-1212D**	9-18	±12	±833	88%
RPP20-1215D**	9-18	±15	±666	88%
RPP20-1224D**	9-18	±24	±416	88%
RPP20-2412D**	18-36	±12	±833	88%
RPP20-2415D**	18-36	±15	±666	89%
RPP20-2424D**	18-36	±24	±416	88%
RPP20-4812D**	36-75	±12	±833	88%
RPP20-4815D**	36-75	±15	±666	88%
RPP20-4824D**	36-75	±24	±416	87%

** add suffix for case options

SUFFIX INFORMATION

none = Standard Ribbed Case
-B = Baseplate Case

For other CTRL logic (-1), case style (-F) or low temperature options (-L, -M, -T) please contact RECOM for availability.

POWERLINE+

DC/DC-Converter

with 3 year Warranty

RECOM

20 Watt

2:1 Single &

Dual Output

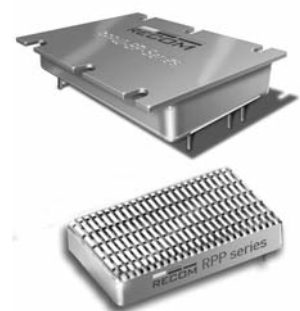

UL-60950-1 Certified
E224736

RPP20

* ICE Technology

ICE (Innovation in Converter Excellence) uses state-of-the-art techniques to minimize internal power dissipation and to increase the internal temperature limits to extend the ambient operating temperature range to the maximum. Refer to Application Notes

Specifications (typical at nominal input and 25°C unless otherwise noted)

Input Voltage Range	12V nominal input	9-18VDC	
	24V nominal input	18-36VDC	
	48V nominal input	36-75VDC	
Under Voltage Lockout	12V input	DC-DC ON (min.)	8.5VDC
		DC-DC OFF (max.)	8VDC
	24V input	DC-DC ON (min.)	17.5VDC
		DC-DC OFF (max.)	17VDC
	48V input	DC-DC ON (min.)	35VDC
		DC-DC OFF (max.)	34VDC
Input Voltage Variation dv/dt (Complies with ETS300 132 part 4.4)		5V/ms max	
Input Surge Voltage (100 ms max.)	12V, 24V Input	50VDC	
	48V Input	100VDC	
Start Up Time	nominal Vin and constant resistor load	20ms typ., 50ms max.	
Remote ON/OFF ⁽⁴⁾	Logic High	Open or 3.0V < Vr < 5.5V	
	Logic Low	Short or 0V < Vr < 1.2V	
Remote OFF input current	Nominal input	2mA typ.	
Output Power		20W	
Output Voltage Accuracy	50% Load and nominal Vin	±1.5%	
Voltage Adjustability	Single Output only	±10%	
Minimum Load		0%	
Line Regulation	low line, high line at full load	±0.3%	
Load Regulation	10% to 100% full load	±0.5%	
Cross Regulation (10% <-> 100% Load)	Dual Outputs only	3% typ. / 5% max.	
Ripple and Noise (20MHz bandwidth limited) (measured with 1µF capacitor across outputs)	3.3V, 5V	100mVp-p typ.	
	All others	1% p-p Vout typ.	
Temperature Coefficient		±0.04%/°C max.	
Transient Response	25% load step change	800µs	
Over Load Protection	% of full load at nominal Vin	120% typ.	
Short Circuit Protection		Power Limit, automatic recovery	
Output Over Voltage Protection (refer to block diagram in Application Notes)		Converter shutdown if Vout > Vout nominal + 20% typ.	
Isolation Voltage		Rated at 1600VDC/1 minute, Flash tested at 2000VDC/1 second	
Isolation Resistance		10MΩ min.	
Isolation Capacitance (refer to block diagram in Application Notes)		1500pF max.	
Operating Frequency		260kHz ± 40kHz	
Operating Temperature Range	Ambient, Free Convection	-40°C to see Calculation (Note 7)	
Maximum Case Temperature		+115°C	
Storage Temperature Range		-55°C to +125°C	
Over Temperature Protection (refer to block diagram in Application Notes)		internal thermistor	
Thermal Impedance (Natural convection)	Ribbed Case: Vertical	7.5°C/Watt	
	Ribbed Case: Horizontal	11.5°C/Watt	
Relative Humidity		5% to 95% RH	
Case Material ⁽⁷⁾		Aluminium	
Potting Material		Silicone (UL94-V0)	

continued on next page

Specifications (cont.)

Weight	Ribbed Case	26g
	Baseplate Case	43g
Packing Quantity	Ribbed Case	5pcs per Tube
	Baseplate Case	4pcs per Tube
Safety Standards	certified UL-60950-1, 1st Edition	
Thermal Cycling	complies with MIL-STD-810F	
Vibration	10-55Hz, 12G, 30 Min. along X, Y and Z	
Conducted Emissions	EN55022	Class B
Radiated Emissions	EN55022	Class B
ESD	EN61000-4-2	Perf. Criteria B
Radiated Immunity	EN61000-4-3	Perf. Criteria A
Fast Transient ⁽⁵⁾	EN61000-4-4	Perf. Criteria B
Surge ⁽⁵⁾	EN61000-4-5	Perf. Criteria B
Conducted Immunity	EN61000-4-6	Perf. Criteria A
MTBF calculated according to BELLCORE TR-NWT-000332 ⁽⁶⁾	2195 x 10 ³ hours	

Notes :

1. Typical values at nominal input voltage and no load/full load.
2. Min. values at nominal input voltage and full load.
3. The ON/OFF pin voltage is referenced to negative input. The pin is pulled high internally.
ON/OFF control is standard with positive logic: e.g. RPP20-2405S, RPP20-4805D-B.
Pos. logic: 0= OFF, 1 = ON. The converter will be ON if the CTRL is left open.
4. Requires an external 100µF low ESR capacitor to meet EN61000-4-4 and EN61000-4-5
5. Case I: 50% Stress, Temperature at 50°C (Ground Benign).
6. To ensure a good all-round electrical contact, the bottom plate is pressed firmly into place into the aluminium case. The hydraulic press can leave tooling marks and deformations to both the case and plate. The case is anodised aluminium, so there will be natural variations in the case colour and the aluminium is not scratch resistant. Any resultant marks, scratches and colour variations are cosmetic only and do not affect the operation or performance of the converters.
7. Example:

$$R_{th\text{case-ambient}} = 7.5^{\circ}\text{C/W (vertical)}$$

$$R_{th\text{case-ambient}} = 11.5^{\circ}\text{C/W (horizontal)}$$

$$R_{th\text{case-ambient}} = \frac{T_{\text{case}} - T_{\text{ambient}}}{P_{\text{dissipation}}}$$

$$P_{\text{dissipation}} = P_{\text{in}} - P_{\text{out}} = \frac{P_{\text{out}}}{\eta} - P_{\text{out}}$$

$$P_{\text{dissipation}} = P_{\text{in}} - P_{\text{out}} = \frac{P_{\text{out}}}{\eta} - P_{\text{out}}$$

Practical Example:

Take the RPP20-1205S with 50% load. What is the maximum ambient operating temperature? Use converter vertical in application.

$$\text{Eff}_{\text{min}} = 89\% @ V_{\text{nom}}$$

$$P_{\text{out}} = 20\text{W}$$

$$P_{\text{outapp}} = 20 \times 0.5 = 10\text{W}$$

$$P_{\text{dissipation}} = \frac{P_{\text{out}}}{\eta} - P_{\text{out}}$$

$$\eta = \sim 88\% \text{ (from Eff vs Load Graph)}$$

$$P_{\text{dissipation}} = \frac{10}{0.88} - 10 = 1.36\text{W}$$

T_{case} = Case Temperature

T_{ambient} = Environment Temperature

$P_{\text{dissipation}}$ = Internal losses

P_{in} = Input Power

P_{out} = Output Power

η = Efficiency under given Operating Conditions

$R_{th\text{case-ambient}}$ = Thermal Impedance

$$R_{th} = \frac{T_{\text{casemax}} - T_{\text{ambient}}}{P_{\text{dissipation}}} \rightarrow 7.5^{\circ}\text{C/W} = \frac{115^{\circ}\text{C} - T_{\text{ambient}}}{1.36\text{W}}$$

$$T_{\text{ambient}} = 104.8^{\circ}\text{C}$$

Typical Characteristics

RPP20-1209S

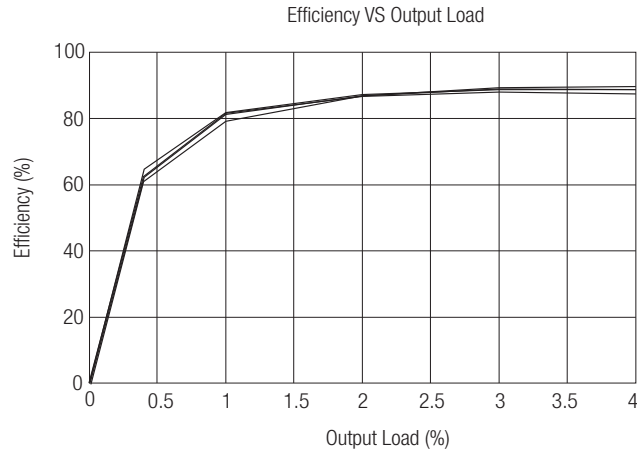

Recommended PCB Layout

Ribbed Case

Single Output

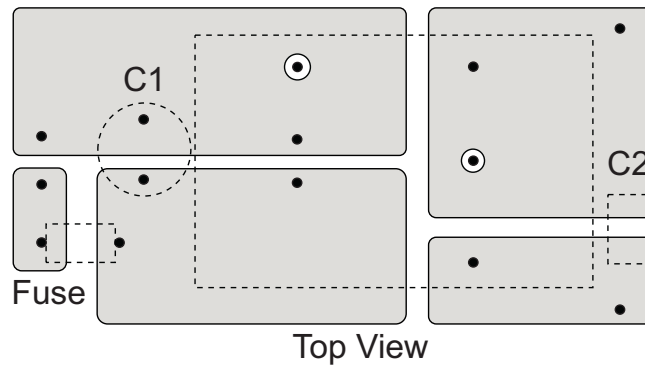

Dual Output

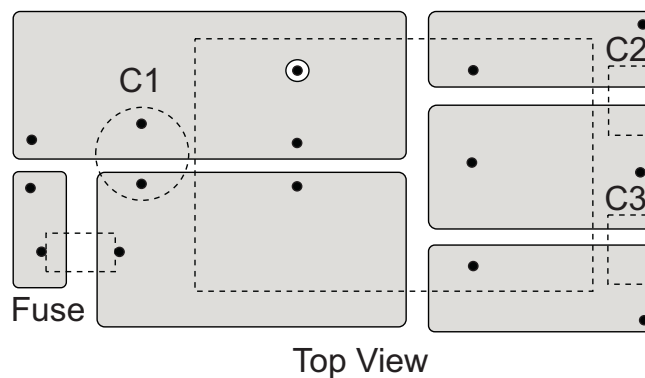

Recommended PCB Layout

Baseplate Case- suggested PCB layout

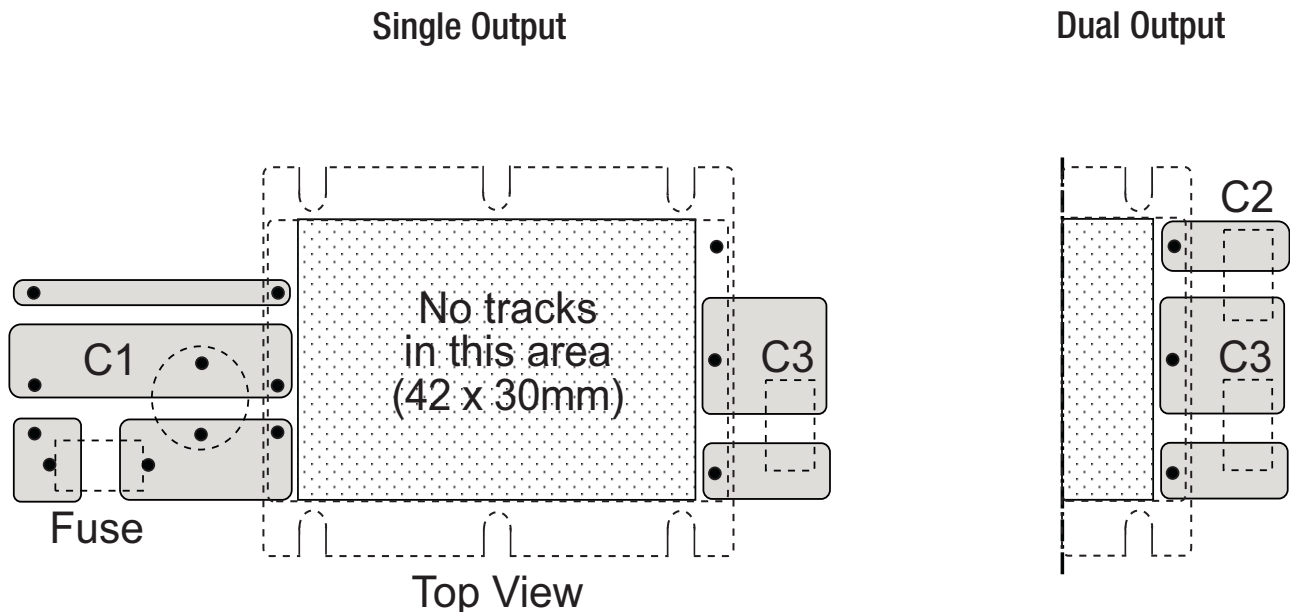

Input Fuse is recommended. Recommended fuse rating = double maximum input current, time delay type.
 Input Capacitor, C1, is required to meet EN61000 Surge and Fast Transient, otherwise it is not required for normal operation.
 Output Capacitors C2/C3 are recommended, but not required for normal operation. Typical capacitor values are 1µF MLCC
 To ensure optimum thermal performance, use large areas of copper on the PCB to assist with heat dissipation and mount the converter vertically.

Package Style and Pinning (mm)

Ribbed Case (Standard - no suffix)

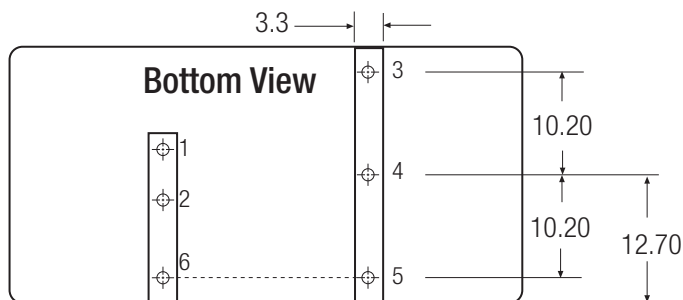
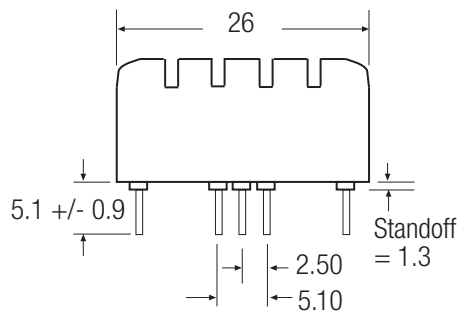
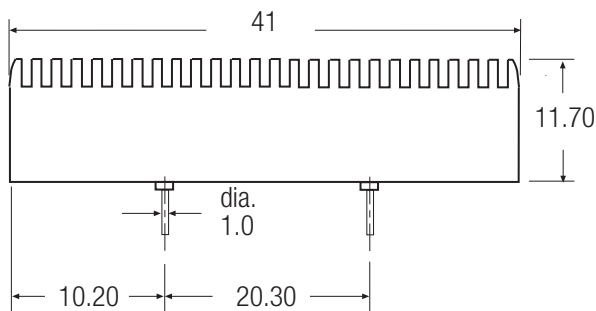

Pin Connections

Pin #	Single	Dual
1	+Vin	+Vin
2	-Vin	-Vin
3	+Vout	+Vout
4	Trim	Com
5	-Vout	-Vout
6	CTRL	CTRL

Pin Pitch Tolerance ±0.35 mm

Package Style and Pinning (mm)

Baseplate Case (-B suffix)

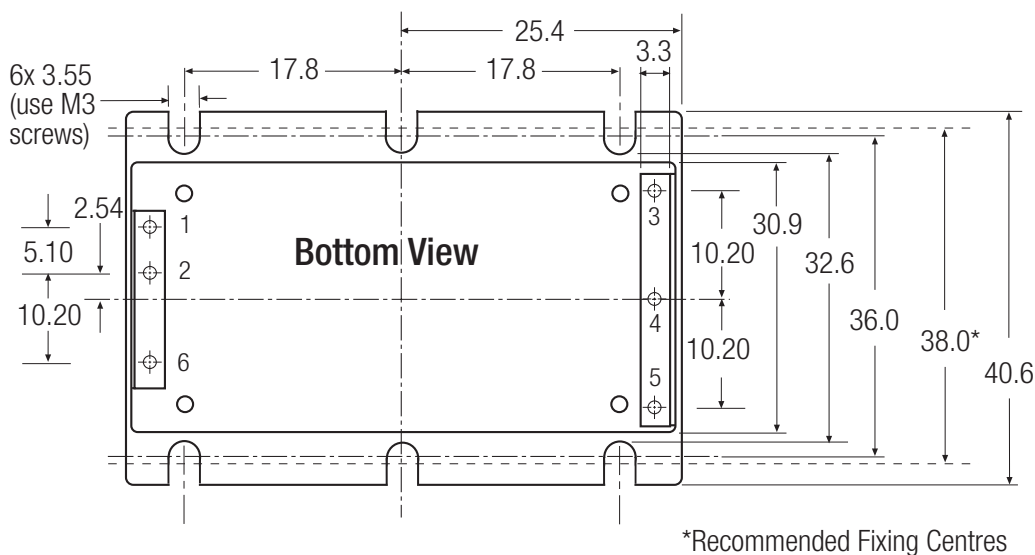
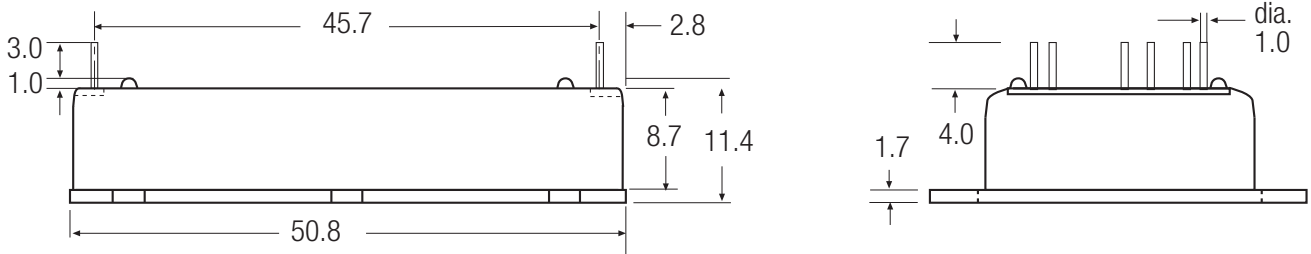

NOTE:
Pin separation is different between ribbed and baseplate versions.

Pin Connections

Pin #	Single	Dual
1	+Vin	+Vin
2	-Vin	-Vin
3	+Vout	+Vout
4	-Vout	Com
5	Trim	-Vout
6	CTRL	CTRL

Pin Pitch Tolerance ± 0.35 mm

*Recommended Fixing Centres

Baseplate Case Fixing - Mounting onto Heatsink/Bulkhead

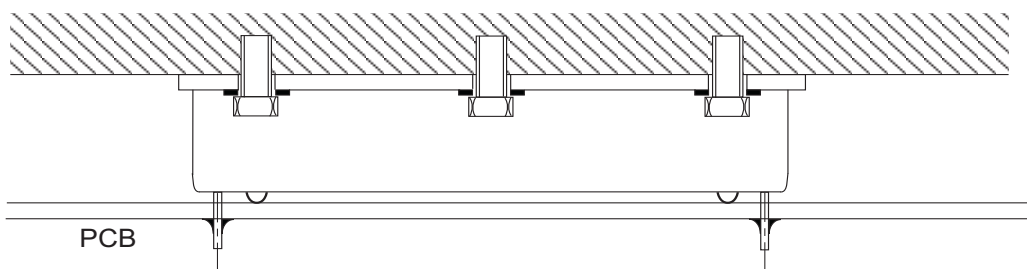

Baseplate Case Fixing - Anti Vibration Mounting onto PCB

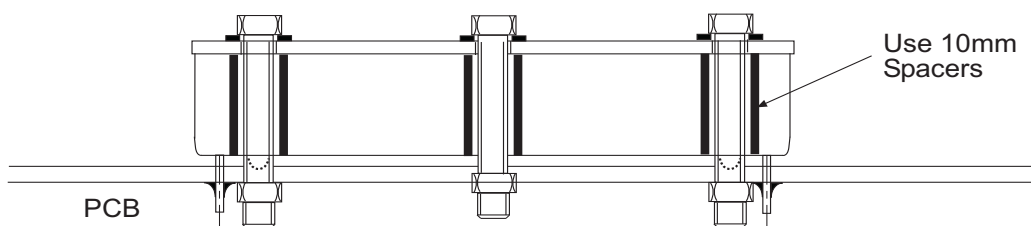

Features

ICE Technology*

- 115°C Maximum Case Temperature
- -40°C Minimum Temp.
- UL Certified
- Built-in FCC/EN55022 Class B Filter
- 4:1 Wide Input Voltage Range
- Six Sided Shielded Enclosure
- Ribbed or Baseplate Case Styles
- Min. Efficiency 86%
- 2kVDC Isolation
- Low Quiescent Current

Description

The RPP20-W series 4:1 input range DC/DC converters are ideal for high end industrial applications and COTS Military applications where a very wide operating temperature range of -40°C to +115°C is required. Although the case size is compact, the converter contains a built-in filter EN55022 Class B / FCC Level B without the need for any external components. The RPP20-W is available in two case styles: the ribbed case for active cooling and the baseplate case for high vibration, bulkhead-mounting or for passive cooling applications. They are UL-60950-1 certified.

Selection Guide 24V and 48V 4:1 Input Types

Part Number	Input Range VDC	Output Voltage VDC	Output Current mA	Input ⁽¹⁾ Current mA	Efficiency ⁽²⁾ (Min.)
RPP20-243.3SW**	9-36	3.3	6000	59/955	87%
RPP20-2405SW**	9-36	5	4000	65/946	86%
RPP20-2412SW**	9-36	12	1666	23/946	86%
RPP20-2415SW**	9-36	15	1333	25/931	86%
RPP20-2424SW**	9-36	24	830	25/931	86%
RPP20-483.3SW**	18-75	3.3	6000	28/465	87%
RPP20-4805SW**	18-75	5	4000	33/465	86%
RPP20-4812SW**	18-75	12	1666	13/470	86%
RPP20-4815SW**	18-75	15	1333	12/466	86%
RPP20-4824SW**	18-75	24	830	12/466	86%
RPP20-2412DW**	9-36	±12	±833	28/930	86%
RPP20-2415DW**	9-36	±15	±666	24/946	87%
RPP20-2424DW**	9-36	±24	±416	24/946	87%
RPP20-4812DW**	18-75	±12	±833	16/472	86%
RPP20-4815DW**	18-75	±15	±666	13/466	87%
RPP20-4824DW**	18-75	±24	±416	13/466	87%

** add suffix for case options

SUFFIX INFORMATION

none = Standard Ribbed Case
-B = Baseplate Case

For other CTRL logic (-1), case style (-F) or low temperature options (-L, -M, -T) please contact RECOM for availability.

POWERLINE+

DC/DC-Converter

with 3 year Warranty

RECOM

20 Watt

4:1 Single & Dual Output

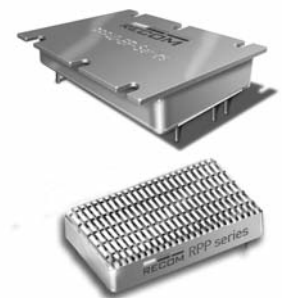

UL-60950-1 Certified
E224736

RPP20-W

* ICE Technology

ICE (Innovation in Converter Excellence) uses state-of-the-art techniques to minimise internal power dissipation and to increase the internal temperature limits to extend the ambient operating temperature range to the maximum. Refer to Application Notes

Specifications (typical at nominal input and 25°C unless otherwise noted)

Input Voltage Range	24V nominal input	9-36VDC	
	48V nominal input	18-75VDC	
Under Voltage Lockout	24V input	DC-DC ON (min.)	8.5VDC
		DC-DC OFF (max.)	8VDC
	48V input	DC-DC ON (min.)	17.5VDC
		DC-DC OFF (max.)	17VDC
Input Filter	Common Mode EMC Filter		
Input Surge Voltage (100 ms max.)	24V Input	50VDC	
	48V Input	100VDC	
Input Reflected Ripple	nominal Vin and full load	200mA _{p-p}	
Start Up Time	nominal Vin and constant resistor load	20ms typ., 50ms max.	
Remote ON/OFF ⁽³⁾	Logic High	Open or 3.0V < Vr < 5.5V	
	Logic Low	Short or 0V < Vr < 1.2V	
Remote OFF input current	Nominal input	2mA typ.	
Output Power	20W		
Output Voltage Accuracy	Nominal Vin	±1.5%	
Voltage Adjustability	Single Output only	±5%	
Minimum Load	0%		
Line Regulation	low line, high line at full load	±0.3%	
Load Regulation	10% to 100% full load	±0.5%	
Cross Regulation (10% <> 100% Load)	Dual Outputs only	3% typ. / 5% max.	
Ripple and Noise (20MHz bandwidth limited) (measured with 1µF capacitor across outputs)	3.3V	100mV _{p-p} typ.	
	All others	40mV-75mV _{p-p} typ.	
Temperature Coefficient	±0.04%/°C max.		
Transient Response	25% load step change	800µs	
Over Load Protection	% of full load at nominal Vin	120% typ.	
Short Circuit Protection	Power Limit, automatic recovery		
Output Over Voltage Protection (refer to block diagram in Application Notes)	Converter shutdown if Vout > Vout nominal + 20%		
Isolation Voltage	Rated at 1600VDC/1 minute, Flash tested at 2000VDC/1 second		
Isolation Resistance	10MΩ min.		
Isolation Capacitance (refer to block diagram in Application Notes)	1500pF max.		
Operating Frequency	260kHz ± 40kHz		
Operating Temperature Range	Ambient, Free Convection	-40°C to see Calculation (Note 7)	
Maximum Case Temperature	+115°C		
Storage Temperature Range	-55°C to +125°C		
Over Temperature Protection (refer to block diagram in Application Notes)	internal thermistor		
Thermal Impedance (Natural convection)	Ribbed Case: Vertical	7.5°C/Watt	
	Ribbed Case: Horizontal	11.5°C/Watt	
Relative Humidity	5% to 95% RH		
Case Material ⁽⁶⁾	Aluminium		
Potting Material	Silicone (UL94-V0)		

continued on next page

Specifications (typical at nominal input and 25°C unless otherwise noted)

Weight	Ribbed Case	26g
	Baseplate Case	43g
Packing Quantity	Ribbed Case	5 pcs per Tube
	Baseplate Case	Single packed
Safety Standards	certified UL-60950-1, 1st Edition	
Thermal Cycling	complies with MIL-STD-810F	
Vibration	10-55Hz, 12G, 30 Min. along X, Y and Z	
Conducted Emissions	EN55022	Class B
Radiated Emissions	EN55022	Class B
ESD	EN61000-4-2	Perf. Criteria B
Radiated Immunity	EN61000-4-3	Perf. Criteria A
Fast Transient ⁽⁴⁾	EN61000-4-4	Perf. Criteria B
Surge ⁽⁴⁾	EN61000-4-5	Perf. Criteria B
Conducted Immunity	EN61000-4-6	Perf. Criteria A
MTBF calculated according to BELLCORE TR-NWT-000332 ⁽⁵⁾	2195 x 10 ³ hours	

Notes :

1. Typical values at nominal input voltage and no load/full load.
2. Min. values at nominal input voltage and full load.
3. The ON/OFF pin voltage is referenced to negative input. The pin is pulled high internally.
ON/OFF control is standard with positive logic: e.g. RPP20-2405SW, RPP20-4805DW-B.
Positive logic: 0= OFF, 1 = ON. The converter will be ON if the CTRL is left open.
4. Requires an external 100µF low ESR capacitor to meet EN61000-4-4 and EN61000-4-5
5. Case I: 50% Stress, Temperature at 50°C (Ground Benign).
6. To ensure a good all-round electrical contact, the baseplate is pressed firmly into place within the aluminium housing. The hydraulic press can leave tooling marks and deformations to both the housing and baseplate. The case is anodised aluminium, so there will be natural variations in the case colour and the aluminium is not scratch resistant. Any resultant marks, scratches and colour variations are cosmetic only and do not affect the operation or performance of the converters.
7. Example:

$$R_{th\text{case-ambient}} = 7.5^{\circ}\text{C/W (vertical)}$$

$$R_{th\text{case-ambient}} = 11.5^{\circ}\text{C/W (horizontal)}$$

$$R_{th\text{case-ambient}} = \frac{T_{\text{case}} - T_{\text{ambient}}}{P_{\text{dissipation}}}$$

$$P_{\text{dissipation}} = P_{\text{in}} - P_{\text{out}} = \frac{P_{\text{out}}}{\eta} - P_{\text{out}}$$

T_{case} = Case Temperature

T_{ambient} = Environment Temperature

$P_{\text{dissipation}}$ = Internal losses

P_{in} = Input Power

P_{out} = Output Power

η = Efficiency under given Operating Conditions

$R_{th\text{case-ambient}}$ = Thermal Impedance

$$P_{\text{dissipation}} = P_{\text{in}} - P_{\text{out}} = \frac{P_{\text{out}}}{\eta} - P_{\text{out}}$$

Practical Example:

Take the RPP20-2405SW with 60% load. What is the maximum ambient operating temperature? Use converter vertical in application.

$$\text{Eff}_{\text{min}} = 86\% @ V_{\text{nom}}$$

$$P_{\text{out}} = 20\text{W}$$

$$P_{\text{outapp}} = 20 \times 0.6 = 12\text{W}$$

$$P_{\text{dissipation}} = \frac{P_{\text{out}}}{\eta} - P_{\text{out}}$$

$$\eta = \sim 85\% \text{ (from Eff vs Load Graph)}$$

$$P_{\text{dissipation}} = \frac{12}{0.85} - 12 = 2.12\text{W}$$

$$R_{\text{th}} = \frac{T_{\text{casemax}} - T_{\text{ambient}}}{P_{\text{dissipation}}} \rightarrow 7.5^{\circ}\text{C/W} = \frac{115^{\circ}\text{C} - T_{\text{ambient}}}{2.12\text{W}}$$

$$T_{\text{ambient}} = 99.1^{\circ}\text{C}$$

Typical Characteristics

External Output Trimming
Refer To Application Notes for recommended resistor Values

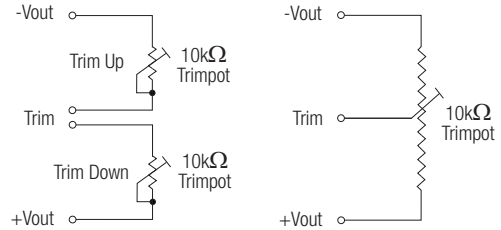

RPP20-2405SW

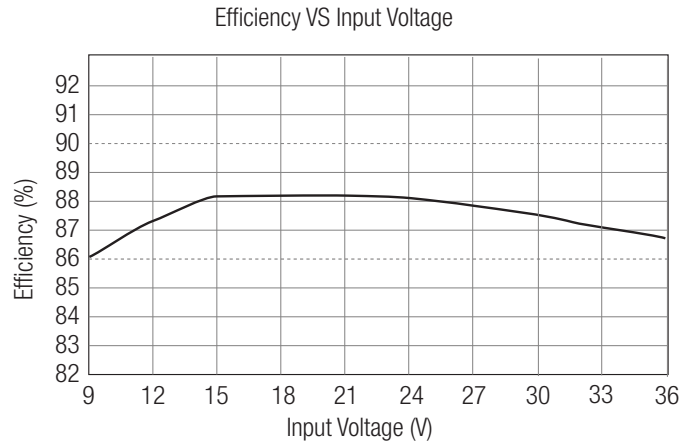
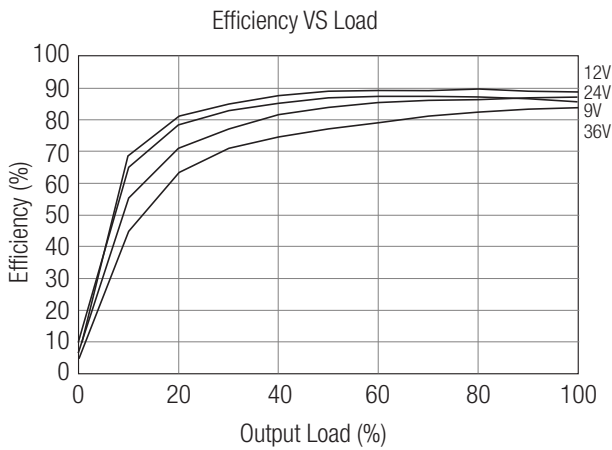

RPP20-W

Recommended PCB Layout

Ribbed Case

Single Output

Dual Output

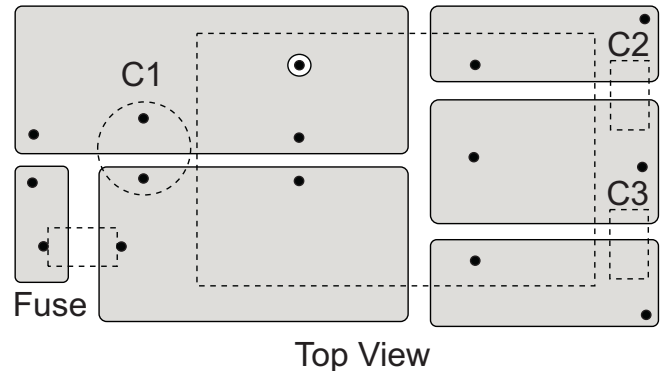
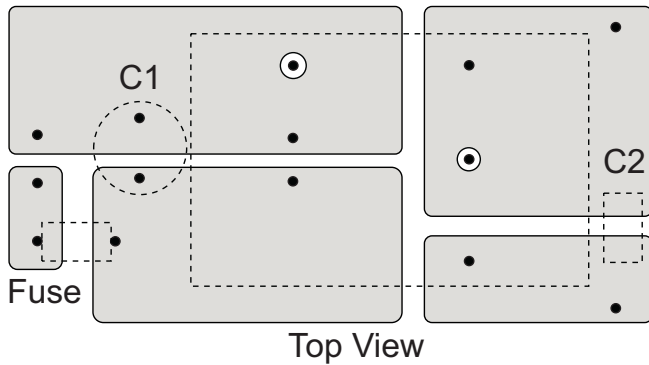

Recommended PCB Layout

Baseplate Case- suggested PCB layout

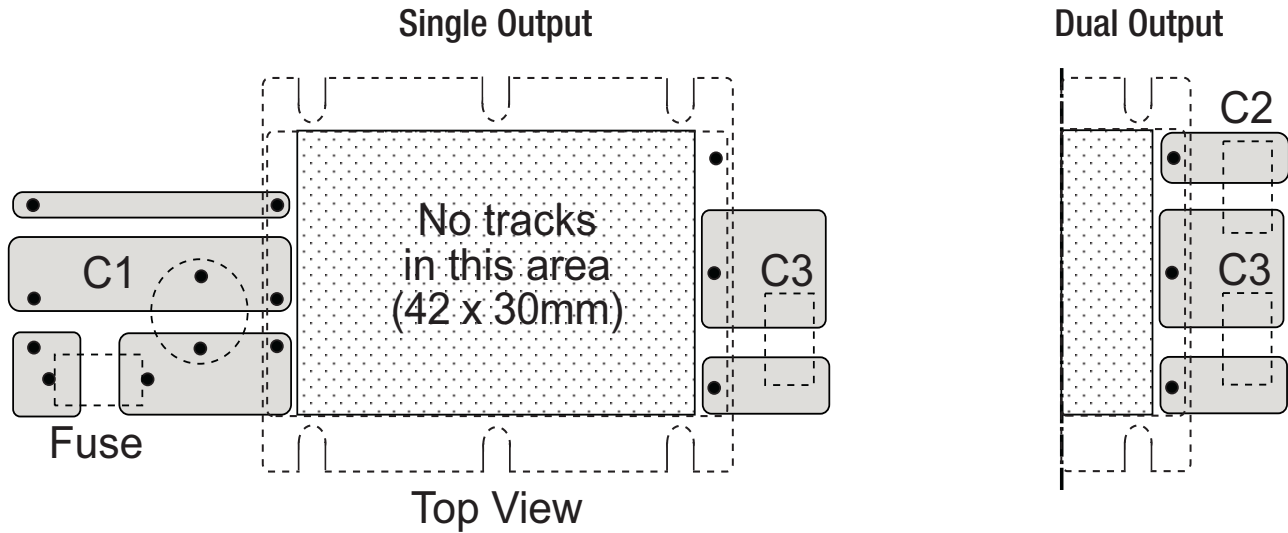

Input Fuse is recommended. Recommended fuse rating = double maximum input current, time delay type.

Input Capacitor, C1, is required to meet EN61000 Surge and Fast Transient, otherwise it is not required for normal operation.

Output Capacitors C2/C3 are recommended, but not required for normal operation. Typical capacitor values are 1µF MLCC

To ensure optimum thermal performance, use large areas of copper on the PCB to assist with heat dissipation and mount the converter vertically.

Package Style and Pinning (mm)

Ribbed Case (Standard - no suffix)

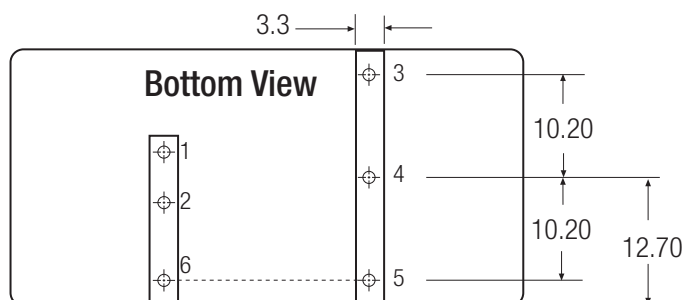
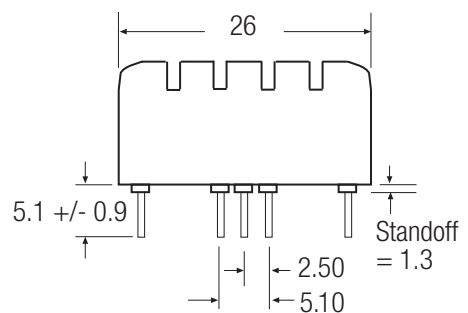
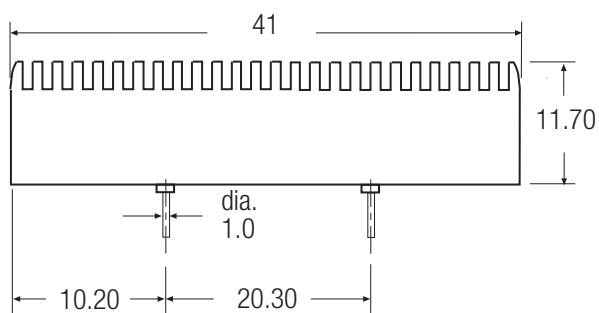

Pin Connections

Pin #	Single	Dual
1	+Vin	+Vin
2	-Vin	-Vin
3	+Vout	+Vout
4	Trim	Com
5	-Vout	-Vout
6	CTRL	CTRL

Pin Pitch Tolerance ± 0.35 mm

Package Style and Pinning (mm)

Baseplate Case (-B Suffix)

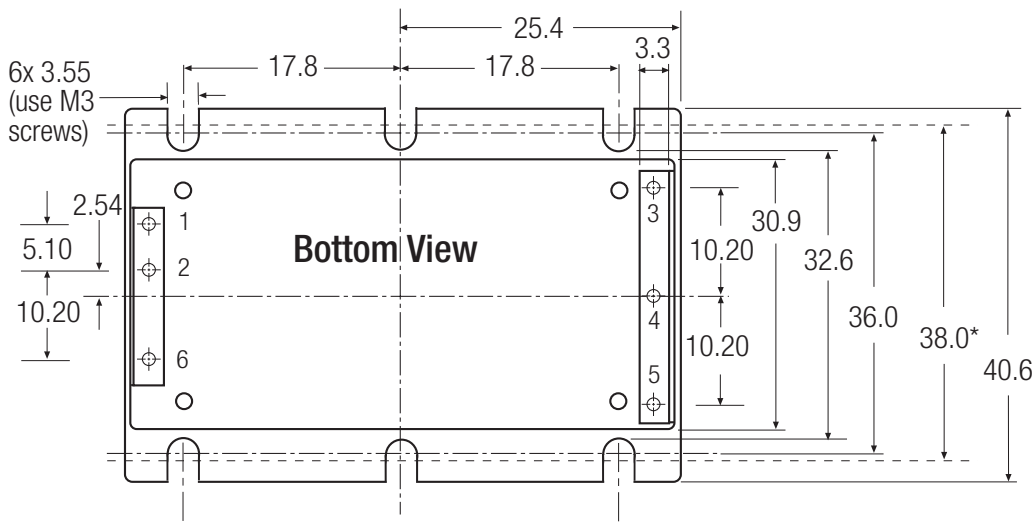
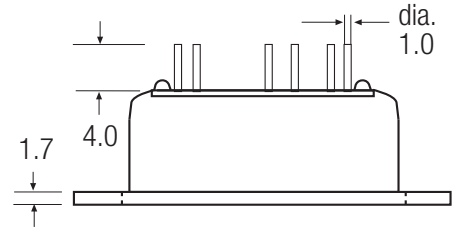
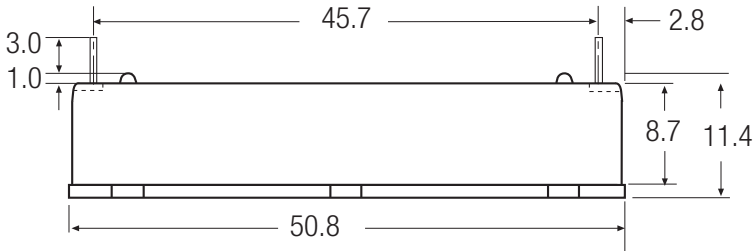

NOTE:
Pin separation is different between ribbed and baseplate versions.

Pin Connections

Pin #	Single	Dual
1	+Vin	+Vin
2	-Vin	-Vin
3	+Vout	+Vout
4	-Vout	Com
5	Trim	-Vout
6	CTRL	CTRL

Pin Pitch Tolerance ± 0.35 mm

*Recommended Fixing Centres

Baseplate Case Fixing - Mounting onto Heatsink/Bulkhead

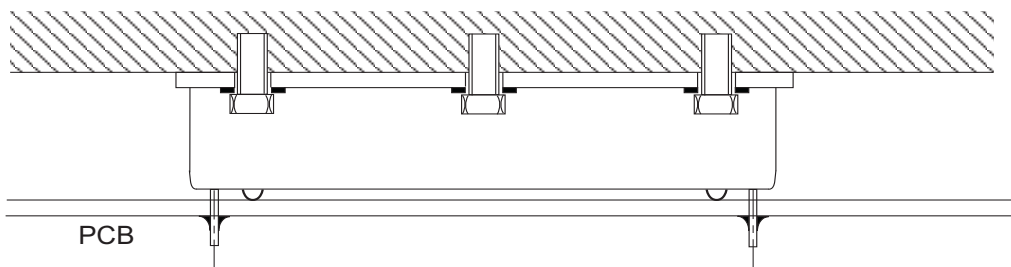

Baseplate Case Fixing - Anti Vibration Mounting onto PCB

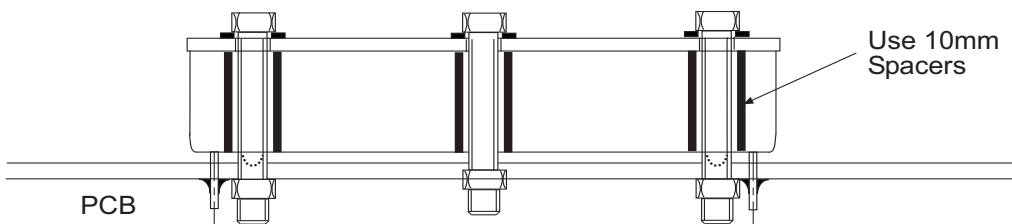

Features

ICE Technology*

- 115°C Maximum Case Temperature
- -40°C Minimum Temp.
- Built-in FCC/EN55022 Class B Filter
- 2:1 Wide Input Voltage Range
- Six Sided Shielded Enclosure
- Ribbed or Baseplate Case Styles
- Min. Efficiency 87%
- 3kVDC Isolation
- Low Quiescent Current

Description

The RPP30 series 2:1 input range DC/DC converters are ideal for high end industrial applications and COTS Military applications where a very wide operating temperature range of -40°C to +115°C is required. Although the case size is compact, the converter contains a built-in filter EN55022 Class B / FCC Level B without the need for any external components. The RPP30 is available in two case styles: the ribbed case and the baseplate case for high vibration, bulkhead-mounting or for passive cooling applications. They are UL-60950-1 certified.

Selection Guide 12V, 24V and 48V Input Types

Part Number	Input Range VDC	Output Voltage VDC	Output Current mA	Efficiency ⁽²⁾
RPP30-123.3S	9-18	3.3	8500	87%
RPP30-1205S	9-18	5	6000	89%
RPP30-1212S	9-18	12	2500	88%
RPP30-1215S	9-18	15	2000	89%
RPP30-1224S	9-18	24	1250	89%
RPP30-243.3S	18-36	3.3	8000	87%
RPP30-2405S	18-36	5	6000	89%
RPP30-2412S	18-36	12	2500	88%
RPP30-2415S	18-36	15	2000	89%
RPP30-2424S	18-36	24	1250	88%
RPP30-483.3S	36-75	3.3	8000	88%
RPP30-4805S	36-75	5	6000	89%
RPP30-4812S	36-75	12	2500	89%
RPP30-4815S	36-75	15	2000	89%
RPP30-4824S	36-75	24	1250	88%
RPP30-1212D	9-18	±12	±1250	88%
RPP30-1215D	9-18	±15	±1000	89%
RPP30-1224D	9-18	±24	±625	89%
RPP30-2412D	18-36	±12	±1250	88%
RPP30-2415D	18-36	±15	±1000	89%
RPP30-2424D	18-36	±24	±625	88%
RPP30-4812D	36-75	±12	±1250	89%
RPP30-4815D	36-75	±15	±1000	89%
RPP30-4824D	36-75	±24	±625	88%

** add suffix for case options

SUFFIX INFORMATION

none = Standard Ribbed Case

-B = Baseplate Case

For other CTRL logic (-1), case style (-F) or low temperature options (-L, -M, -T) please contact RECOM for availability.

POWERLINE+

DC/DC-Converter

with 3 year Warranty

RECOM

30 Watt

2:1 Single &

Dual Output



UL-60950-1 Certified
E224736

RPP30

* ICE Technology

ICE (Innovation in Converter Excellence) uses state-of-the-art techniques to minimise internal power dissipation and to increase the internal temperature limits to extend the ambient operating temperature range to the maximum. Refer to Application Notes

Specifications (typical at nominal input and 25°C unless otherwise noted)

Input Voltage Range	12V nominal input	9-18VDC	
	24V nominal input	18-36VDC	
	48V nominal input	36-75VDC	
Under Voltage Lockout	12V input	DC-DC ON (min.)	8.5VDC
		DC-DC OFF (max.)	8VDC
	24V input	DC-DC ON (min.)	17.5VDC
		DC-DC OFF (max.)	17VDC
	48V input	DC-DC ON (min.)	35VDC
		DC-DC OFF (max.)	34VDC
Input Filter		Common Mode EMCType	
Input Surge Voltage (100 ms max.)	12V, 24V Input	50VDC	
	48V Input	100VDC	
Start Up Time	nominal Vin and constant resistor load	20ms typ., 50ms max.	
Remote ON/OFF ⁽⁴⁾	DC-DC ON	Open or 3.0V < Vr < 5.5V	
	DC-DC OFF	Short or 0V < Vr < 1.2V	
Remote OFF input current	Nominal input	2mA typ.	
Output Power		30W	
Output Voltage Accuracy	50% Load and nominal Vin	±1.5%	
Voltage Adjustability	Single Output only	±10%	
Minimum Load		0%	
Line Regulation	low line, high line at full load	±0.3%	
Load Regulation	10% to 100% full load	±0.5%	
Cross Regulation (10% <> 100% Load)	Dual Outputs only	3% typ./ 5% max.	
Ripple and Noise (20MHz bandwidth limited) (measured with 1µF capacitor across outputs)	3.3V, 5V	100mVp-p typ.	
	All others	1% p-p Vout typ.	
Temperature Coefficient		±0.04%/°C max.	
Transient Response	25% load step change	800µs	
Over Load Protection	% of full load at nominal Vin	120% typ.	
Short Circuit Protection		Power Limit, automatic recovery	
Output Over Voltage Protection (refer to block diagram in Application Notes)		Converter shutdown if Vout > Vout nominal + 20% typ.	
Isolation Voltage		Rated at 2250VDC/1 minute, Flash tested at 3000VDC/1 second	
Isolation Resistance		10MΩ min.	
Isolation Capacitance (refer to block diagram in Application Notes)		3000pF max.	
Operating Frequency		260kHz ± 40kHz	
Operating Temperature Range	Ambient, Free Convection	-40°C to see Calculation (Note 7)	
Maximum Case Temperature		+115°C	
Storage Temperature Range		-55°C to +125°C	
Over Temperature Protection (refer to block diagram in Application Notes)		internal thermistor	
Thermal Impedance (Natural convection)	Ribbed Case: Vertical	7.3°C/Watt	
	Ribbed Case: Horizontal	10°C/Watt	
Relative Humidity		5% to 95% RH	
Case Material ⁽⁷⁾		Aluminium	
Potting Material		Silicone (UL94-V0)	

continued on next page

Specifications (typical at nominal input and 25°C unless otherwise noted)

Weight	Ribbed Case	39g
	Baseplate Case	43g
Packing Quantity	4 pcs per Tube	
Safety Standards	certified UL-60950-1, 1st Edition	
Thermal Cycling	complies with MIL-STD-810F	
Vibration	10-55Hz, 12G, 30 Min. along X, Y and Z	
Conducted Emissions	EN55022	Class B
Radiated Emissions	EN55022	Class B
ESD	EN61000-4-2	Perf. Criteria B
Radiated Immunity	EN61000-4-3	Perf. Criteria A
Fast Transient ⁽⁵⁾	EN61000-4-4	Perf. Criteria B
Surge ⁽⁵⁾	EN61000-4-5	Perf. Criteria B
Conducted Immunity	EN61000-4-6	Perf. Criteria A
MTBF calculated according to BELLCORE TR-NWT-000332 ⁽⁶⁾	2195 x 10 ³ hours	

Notes :

1. Typical values at nominal input voltage and no load/full load.
2. Min. values at nominal input voltage and full load.
3. The ON/OFF pin voltage is referenced to negative input. The pin is pulled high internally
ON/OFF control is standard with positive logic: e.g. RPP30-2405S, RPP30-4805D-B
Positive logic: 0= OFF, 1 = ON. The converter will be ON if the CTRL is left open.
4. Requires an external 100µF low ESR capacitor to meet EN61000-4-4 and EN61000-4-5
5. Case I: 50% Stress, Temperature at 50°C (Ground Benign).
6. To ensure a good all-round electrical contact, the baseplate is pressed firmly into place within the aluminium housing. The hydraulic press can leave tooling marks and deformations to both the housing and baseplate. The case is anodised aluminium, so there will be natural variations in the case colour and the aluminium is not scratch resistant. Any resultant marks, scratches and colour variations are cosmetic only and do not affect the operation or performance of the converters.

Example:

$$R_{th\text{case-ambient}} = 7.5^{\circ}\text{C/W (vertical)}$$

$$R_{th\text{case-ambient}} = 11.5^{\circ}\text{C/W (horizontal)}$$

$$R_{th\text{case-ambient}} = \frac{T_{\text{case}} - T_{\text{ambient}}}{P_{\text{dissipation}}}$$

$$P_{\text{dissipation}} = P_{\text{in}} - P_{\text{out}} = \frac{P_{\text{out}}}{\eta} - P_{\text{out}}$$

T_{case} = Case Temperature

T_{ambient} = Environment Temperature

$P_{\text{dissipation}}$ = Internal losses

P_{in} = Input Power

P_{out} = Output Power

η = Efficiency under given Operating Conditions

$R_{th\text{case-ambient}}$ = Thermal Impedance

$$P_{\text{dissipation}} = P_{\text{in}} - P_{\text{out}} = \frac{P_{\text{out}}}{\eta} - P_{\text{out}}$$

Practical Example:

Take the RPP20-1205S with 50% load. What is the maximum ambient operating temperature? Use converter vertical in application.

$$Eff_{\text{min}} = 89\% @ V_{\text{nom}}$$

$$P_{\text{out}} = 20\text{W}$$

$$P_{\text{outapp}} = 20 \times 0.5 = 10\text{W}$$

$$P_{\text{dissipation}} = \frac{P_{\text{out}}}{\eta} - P_{\text{out}}$$

$$\eta = \sim 88\% \text{ (from Eff vs Load Graph)}$$

$$P_{\text{dissipation}} = \frac{10}{0.88} - 10 = 1.36\text{W}$$

$$R_{th} = \frac{T_{\text{casemax}} - T_{\text{ambient}}}{P_{\text{dissipation}}} \rightarrow 7.5^{\circ}\text{C/W} = \frac{115^{\circ}\text{C} - T_{\text{ambient}}}{1.36\text{W}}$$

$$T_{\text{ambient}} = 104.8^{\circ}\text{C}$$

Typical Characteristics

RPP30-4805S

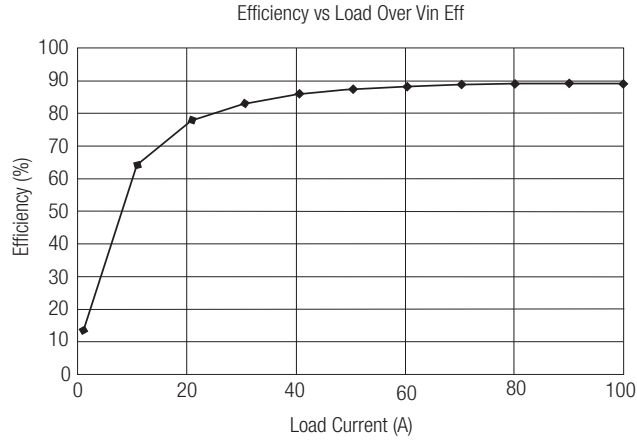

Recommended PCB Layout

Ribbed Case

Single Output

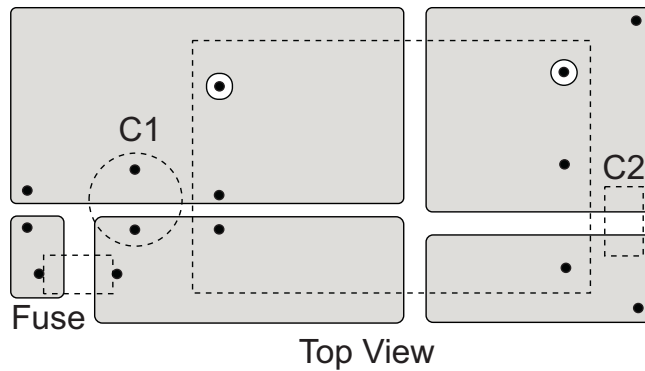

Dual Output

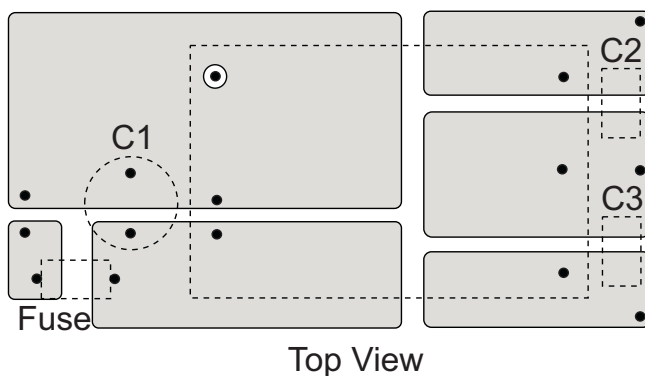

Recommended PCB Layout

Baseplate Case- suggested PCB layout

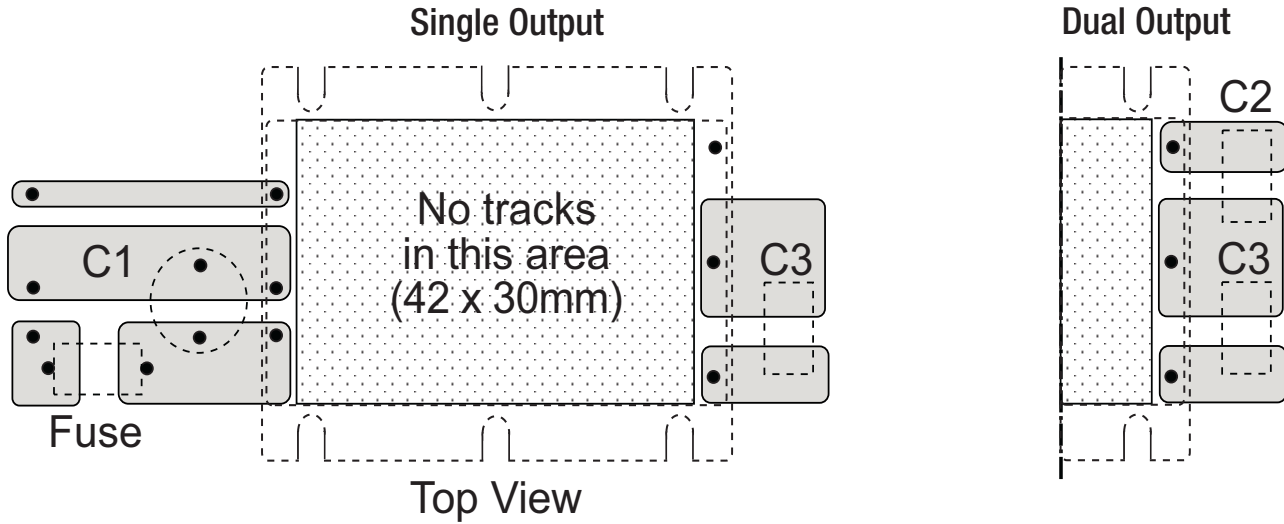

Input Fuse is recommended. Recommended fuse rating = double maximum input current, time delay type.
 Input Capacitor, C1, is required to meet EN61000 Surge and Fast Transient, otherwise it is not required for normal operation.
 Output Capacitors C2/C3 are recommended, but not required for normal operation. Typical capacitor values are 1µF MLCC
 To ensure optimum thermal performance, use large areas of copper on the PCB to assist with heat dissipation and mount the converter vertically.

Package Style and Pinning (mm)

Ribbed Case (Standard - no Suffix)

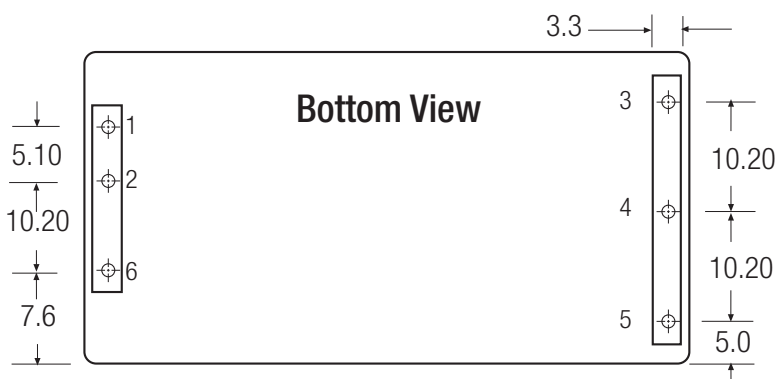
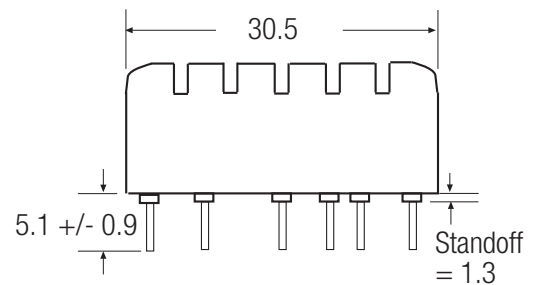
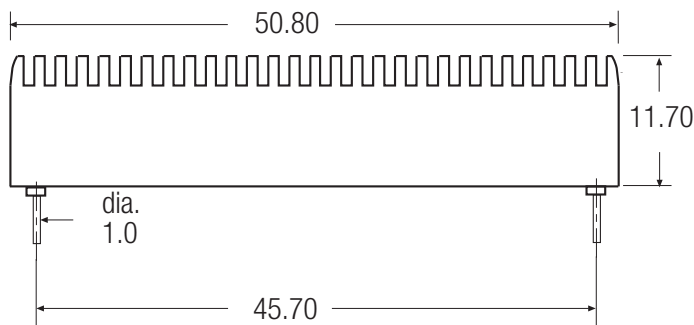

Pin Connections

Pin #	Single	Dual
1	+Vin	+Vin
2	-Vin	-Vin
3	+Vout	+Vout
4	-Vout	Com
5	Trim	-Vout
6	CTRL	CTRL

Pin Pitch Tolerance ±0.35 mm

Package Style and Pinning (mm)

Baseplate Case (-B Suffix)

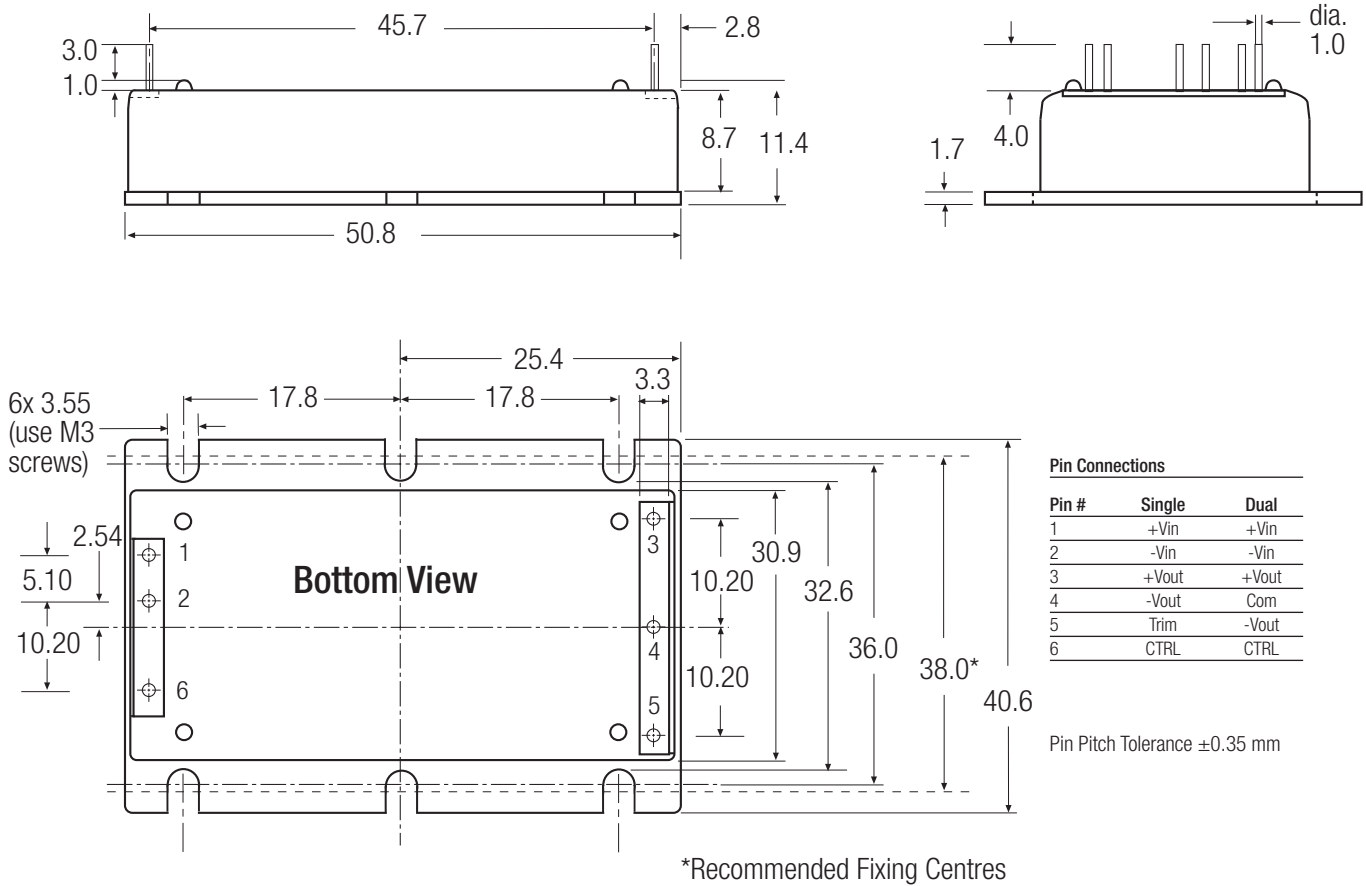

Baseplate Case Fixing - Mounting onto Heatsink/Bulkhead

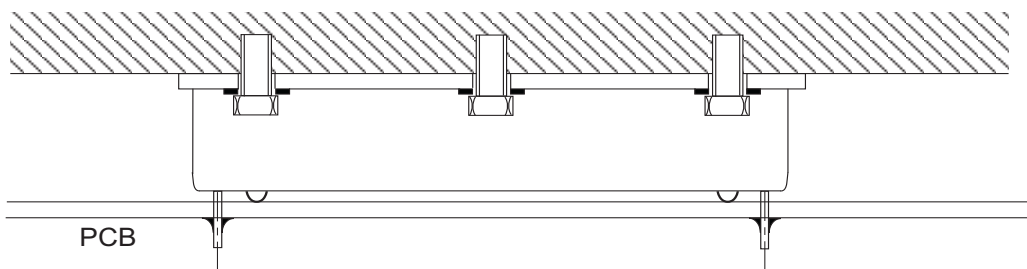

Baseplate Case Fixing - Anti Vibration Mounting onto PCB

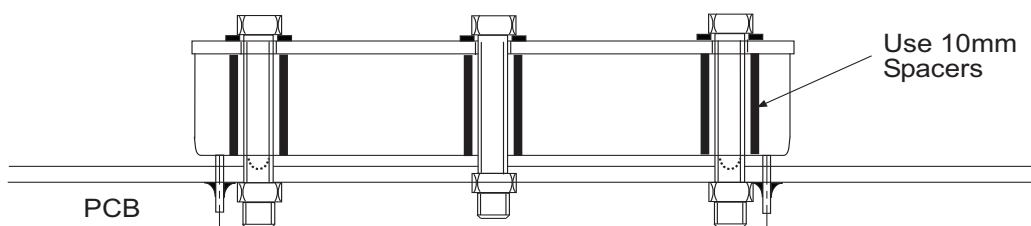

Features

ICE Technology*

- 115°C Maximum Case Temperature
- -40°C Minimum Temp.
- Built-in FCC/EN55022 Class B Filter
- 4:1 Wide Input Voltage Range
- Six Sided Shielded Enclosure
- Ribbed or Baseplate Case Styles
- Min. Efficiency 87%
- 3kVDC Isolation
- Low Quiescent Current

Description

The RPP30-W series 4:1 input range DC/DC converters are ideal for high end industrial applications and COTS Military applications where a very wide operating temperature range of -40°C to +115°C is required. Although the case size is compact, the converter contains a built-in filter EN55022 Class B / FCC Level B without the need for any external components. The RPP30-W is available in two case styles: the ribbed case and the baseplate case for high vibration, bulkhead-mounting or for passive cooling applications. They are UL-60950-1 certified.

Selection Guide 24V and 48V 4:1 Input Types

Part Number	Input Range VDC	Output Voltage VDC	Output Current mA	Input ⁽¹⁾ Current mA	Efficiency ⁽²⁾ (Min.)
RPP30-243.3SW	9-36	3.3	8400	57/1326	87%
RPP30-2405SW	9-36	5	6000	62/1397	89%
RPP30-2412SW	9-36	12	2500	27/1420	87%
RPP30-2415SW	9-36	15	2000	31/1436	87%
RPP30-2424SW	9-36	24	1250	31/1436	87%
RPP30-483.3SW	18-75	3.3	9000	46/704	87%
RPP30-4805SW	18-75	5	6000	38/710	89%
RPP30-4812SW	18-75	12	2500	15/727	87%
RPP30-4815SW	18-75	15	2000	19/718	87%
RPP30-4824SW	18-75	24	1250	19/718	87%
RPP30-2412DW	9-36	±12	±1250	32/1453	87%
RPP30-2415DW	9-36	±15	±1000	30/1436	87%
RPP30-2424DW	9-36	±24	±625	30/1436	87%
RPP30-4812DW	18-75	±12	±1250	18/727	87%
RPP30-4815DW	18-75	±15	±1000	20/718	87%
RPP30-4824DW	18-75	±24	±625	20/718	87%

** add suffix for case options

SUFFIX INFORMATION

none = Standard Ribbed Case
-B = Baseplate Case

For other CTRL logic (-1), case style (-F) or low temperature options (-L, -M, -T) please contact RECOM for availability.

POWERLINE+

DC/DC-Converter

with 3 year Warranty

RECOM

30 Watt 4:1 Single & Dual Output



UL-60950-1 Certified
E224736

RPP30-W

* ICE Technology

ICE (Innovation in Converter Excellence) uses state-of-the-art techniques to minimise internal power dissipation and to increase the internal temperature limits to extend the ambient operating temperature range to the maximum. Refer to Application Notes

Specifications (typical at nominal input and 25°C unless otherwise noted)

Input Voltage Range	24V nominal input	9-36VDC	
	48V nominal input	18-75VDC	
Under Voltage Lockout	24V input	DC-DC ON (min.)	8.5VDC
		DC-DC OFF (max.)	8VDC
	48V input	DC-DC ON (min.)	17.5VDC
		DC-DC OFF (max.)	17VDC
Input Filter	Common Mode EMC Filter		
Input Surge Voltage (100 ms max.)	24V Input	50VDC	
	48V Input	100VDC	
Input Reflected Ripple	nominal Vin and full load	300mA _{p-p}	
Start Up Time	nominal Vin and constant resistor load	20ms typ., 50ms max.	
Remote ON/OFF ⁽³⁾	Logic High	Open or 3.0V < Vr < 5.5V	
	Logic Low	Short or 0V < Vr < 1.2V	
Remote OFF input current	Nominal input	2mA typ.	
Output Power	30W max.		
Output Voltage Accuracy	Nominal Vin	±1.5%	
Voltage Adjustability	Single Output only	±5%	
Minimum Load	0%		
Line Regulation	low line, high line at full load	±0.3%	
Load Regulation	10% to 100% full load	±0.5%	
Cross Regulation (10% <> 100% Load)	Dual Outputs only	3% typ./ 5% max.	
Ripple and Noise (20MHz bandwidth limited) (measured with 1µF MLCC capacitor across outputs)	3.3V, 5V	80mV _{p-p} typ.	
	All others	27mV-60mV _{p-p} max	
Temperature Coefficient	±0.04%/°C max.		
Transient Response	25% load step change	800µs	
Over Load Protection	% of full load at nominal Vin	120% typ.	
Short Circuit Protection	Power Limit, automatic recovery		
Output Over Voltage Protection (refer to block diagram in Application Notes)	Converter shutdown if Vout > Vout nominal +20%		
Isolation Voltage	Rated at 2250VDC/1 minute, Flash tested at 3000VDC/1 second		
Isolation Resistance	10MΩ min.		
Isolation Capacitance (refer to block diagram in Application Notes)	3000pF max.		
Operating Frequency	300kHz ± 30kHz		
Operating Temperature Range	Ambient, Free Convection	-40°C to see Calculation (Note 7)	
Maximum Case Temperature	+115°C		
Storage Temperature Range	-55°C to +125°C		
Over Temperature Protection (refer to block diagram in Application Notes)	internal thermistor		
Thermal Impedance (Natural convection)	Ribbed Case: Vertical	7.3°C/Watt	
	Ribbed Case: Horizontal	10°C/Watt	
Relative Humidity	5% to 95% RH		
Case Material ⁽⁶⁾	Aluminium		
Potting Material	Silicone (UL94-V0)		
Weight	Ribbed Case	39g	
	Baseplate Case	43g	

continued on next page

Specifications (typical at nominal input and 25°C unless otherwise noted)

Packing Quantity	Ribbed Case Baseplate Case	4 pcs per Tube Single packed
Safety Standards		certified UL-60950-1, 1st Edition
Thermal Cycling		complies with MIL-STD-810F
Vibration		10-55Hz, 12G, 30 Min. along X, Y and Z
Conducted Emissions	EN55022	Class B
Radiated Emissions	EN55022	Class B
ESD	EN61000-4-2	Perf. Criteria B
Radiated Immunity	EN61000-4-3	Perf. Criteria A
Fast Transient ⁽⁴⁾	EN61000-4-4	Perf. Criteria B
Surge ⁽⁴⁾	EN61000-4-5	Perf. Criteria B
Conducted Immunity	EN61000-4-6	Perf. Criteria A
MTBF calculated according to BELLCORE TR-NWT-000332 ⁽⁵⁾		2195 x 10 ³ hours

Notes :

1. Typical values at nominal input voltage and no load/full load.
2. Min values at nominal input voltage and full load.
3. The ON/OFF pin voltage is referenced to negative input. The pin is pulled high internally.
ON/OFF control is standard with positive logic: e.g. RPP30-2405SW, RPP30-4805DW-B.
Positive logic: 0= OFF, 1 = ON. The converter will be ON if the CTRL is left open.
4. Requires an external 100µF low ESR capacitor to meet EN61000-4-4 and EN61000-4-5
5. Case I: 50% Stress, Temperature at 50°C (Ground Benign).
6. To ensure a good all-round electrical contact, the baseplate is pressed firmly into place within the aluminium housing. The hydraulic press can leave tooling marks and deformations to both the housing and baseplate. The case is anodised aluminium, so there will be natural variations in the case colour and the aluminium is not scratch resistant. Any resultant marks, scratches and colour variations are cosmetic only and do not affect the operation or performance of the converters.
7. Example:

$$R_{th\text{case-ambient}} = 7.3^{\circ}\text{C/W (vertical)}$$

$$R_{th\text{case-ambient}} = 11^{\circ}\text{C/W (horizontal)}$$

$$R_{th\text{case-ambient}} = \frac{T_{\text{case}} - T_{\text{ambient}}}{P_{\text{dissipation}}}$$

$$P_{\text{dissipation}} = P_{\text{in}} - P_{\text{out}} = \frac{P_{\text{out}}}{\eta} - P_{\text{out}}$$

$$P_{\text{dissipation}} = P_{\text{in}} - P_{\text{out}} = \frac{P_{\text{out}}}{\eta} - P_{\text{out}}$$

Practical Example:

Take the RPP30-2405SW with 90% load. What is the maximum ambient operating temperature? Use converter vertical in application.

$$Eff_{\text{min}} = 89\% @ V_{\text{nom}}$$

$$P_{\text{out}} = 30\text{W}$$

$$P_{\text{outapp}} = 30 \times 0.9 = 27\text{W}$$

$$P_{\text{dissipation}} = \frac{P_{\text{out}}}{\eta} - P_{\text{out}}$$

$$\eta = \sim 89\% \text{ (from Eff vs Load Graph)}$$

$$P_{\text{dissipation}} = \frac{27}{0.89} - 27 = 3.34\text{W}$$

T_{case} = Case Temperature

T_{ambient} = Environment Temperature

$P_{\text{dissipation}}$ = Internal losses

P_{in} = Input Power

P_{out} = Output Power

η = Efficiency under given Operating Conditions

$R_{th\text{case-ambient}}$ = Thermal Impedance

$$R_{th} = \frac{T_{\text{casemax}} - T_{\text{ambient}}}{P_{\text{dissipation}}} \rightarrow 7.3^{\circ}\text{C/W} = \frac{115^{\circ}\text{C} - T_{\text{ambient}}}{3.34\text{W}}$$

$$T_{\text{ambient}} = 90.64^{\circ}\text{C}$$

Typical Characteristics

External Output Trimming

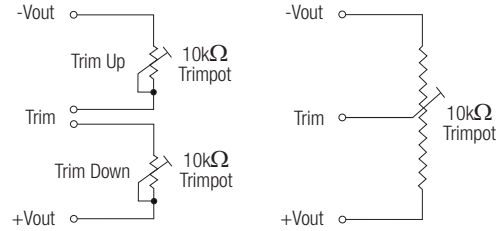

RPP30-4805SW

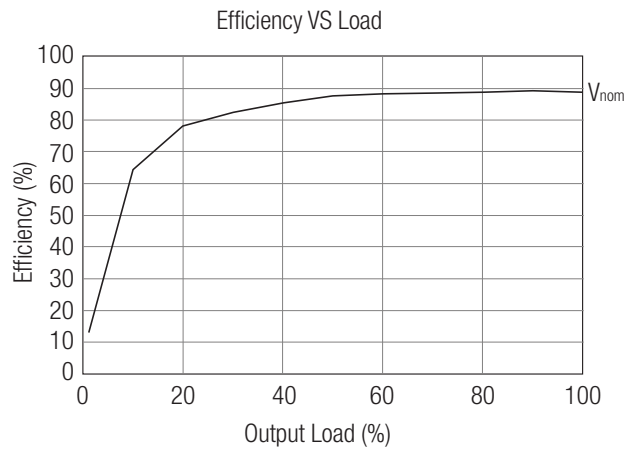

RPP30-W

Recommended PCB Layout

Ribbed Case

Single Output

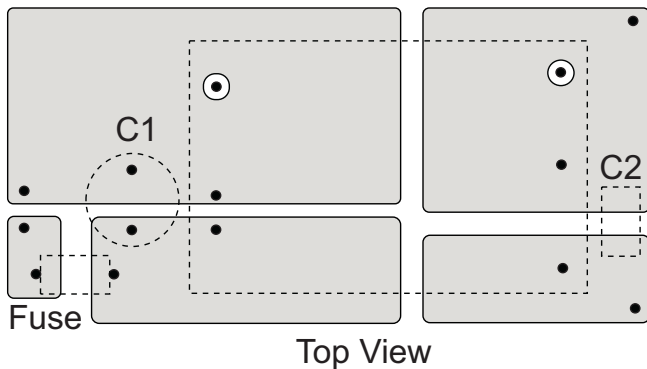

Dual Output

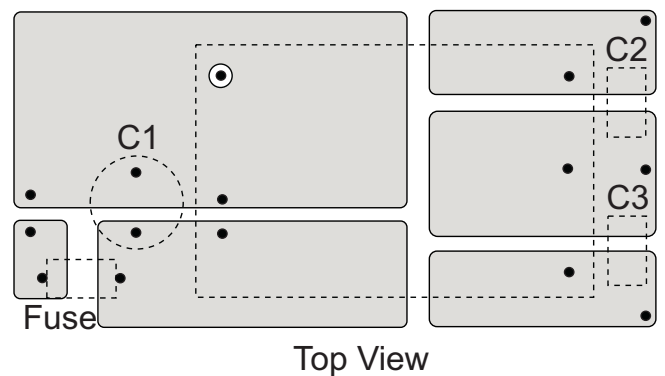

Recommended PCB Layout

Baseplate Case- suggested PCB layout

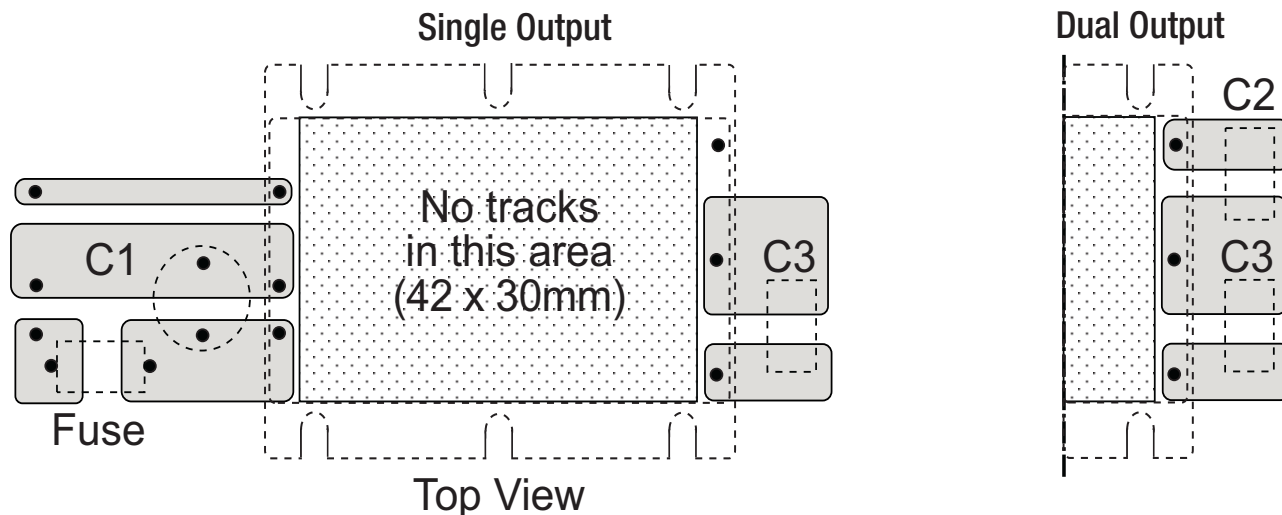

Input Fuse is recommended. Recommended fuse rating = double maximum input current, time delay type.
 Input Capacitor, C1, is required to meet EN61000 Surge and Fast Transient, otherwise it is not required for normal operation.
 Output Capacitors C2/C3 are recommended, but not required for normal operation. Typical capacitor values are 1µF MLCC
 To ensure optimum thermal performance, use large areas of copper on the PCB to assist with heat dissipation and mount the converter vertically.

Package Style and Pinning (mm)

Ribbed Case (Standard - no Suffix)

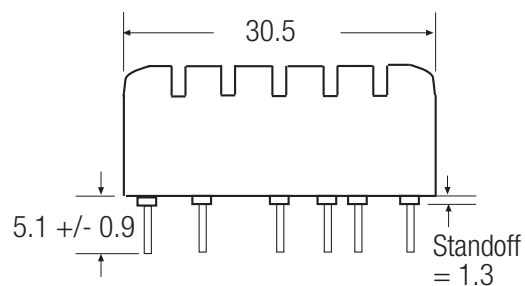
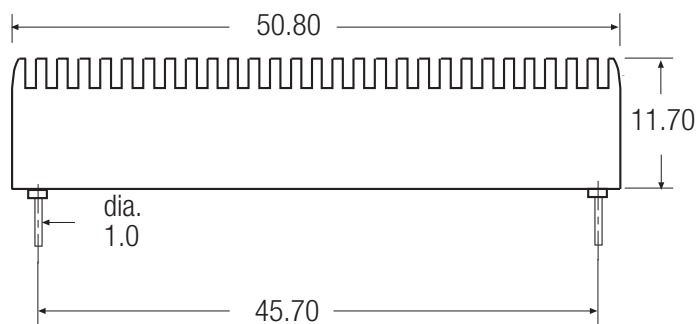

RPP30-W

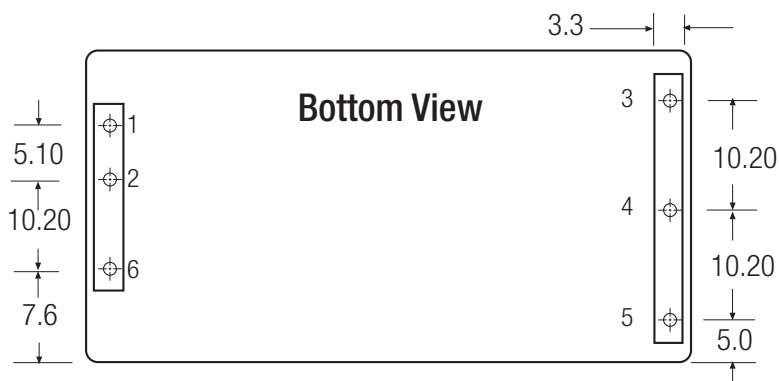

Pin Connections

Pin #	Single	Dual
1	+Vin	+Vin
2	-Vin	-Vin
3	+Vout	+Vout
4	-Vout	Com
5	Trim	-Vout
6	CTRL	CTRL

Pin Pitch Tolerance ±0.35 mm

Package Style and Pinning (mm)

Baseplate Case (-B Suffix)

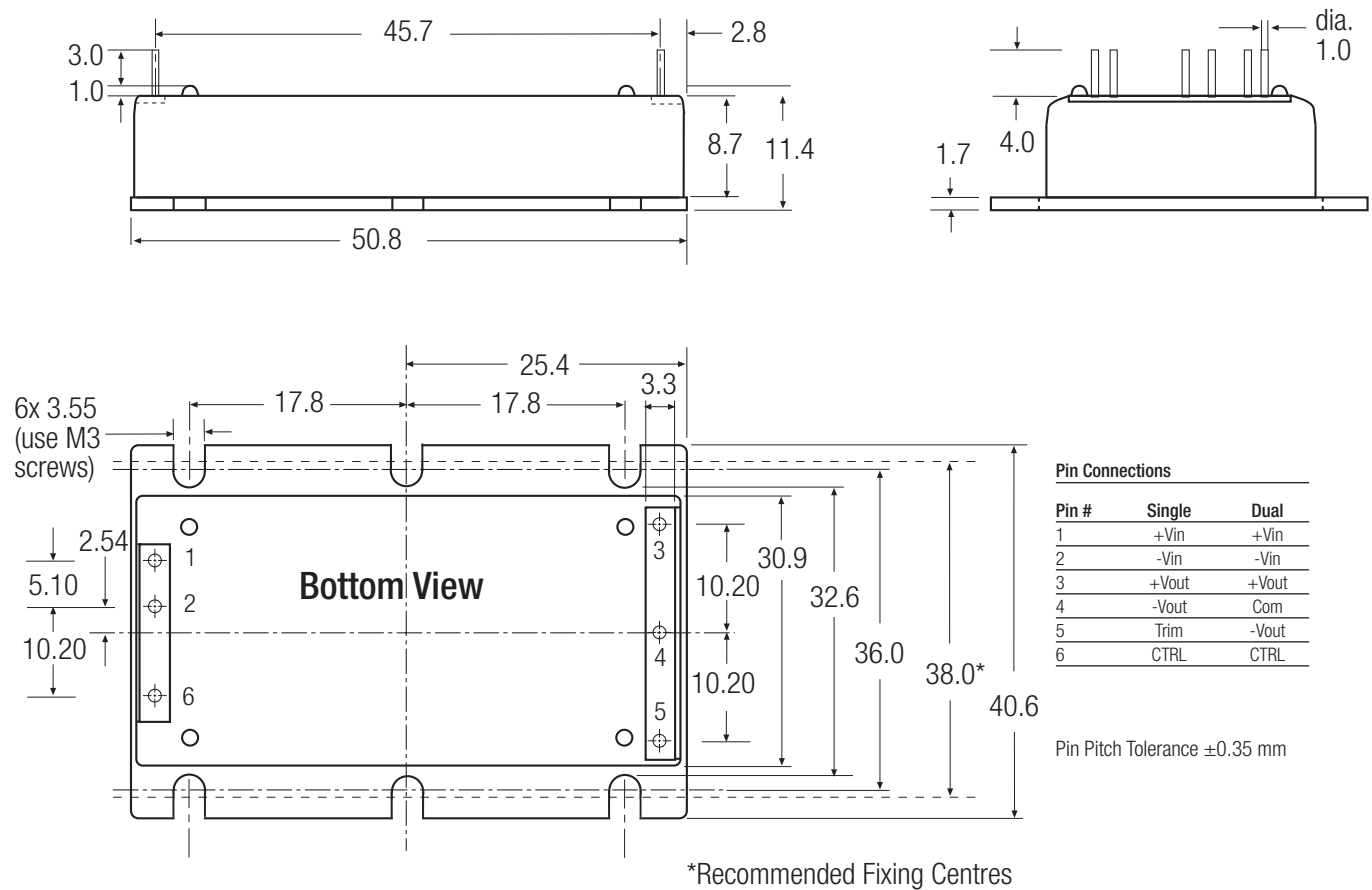

RPP30-W

Baseplate Case Fixing - Mounting onto Heatsink/Bulkhead

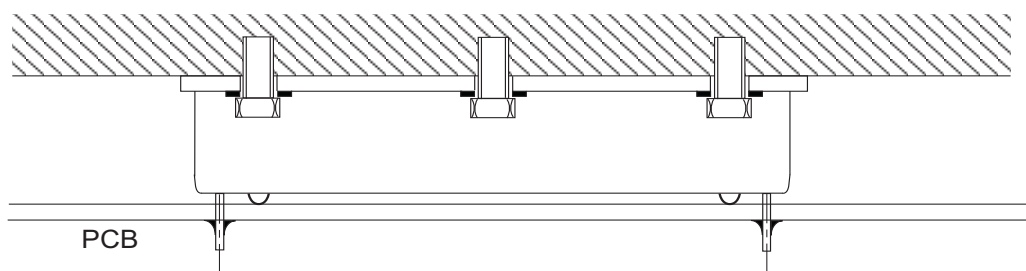

Baseplate Case Fixing - Anti Vibration Mounting onto PCB

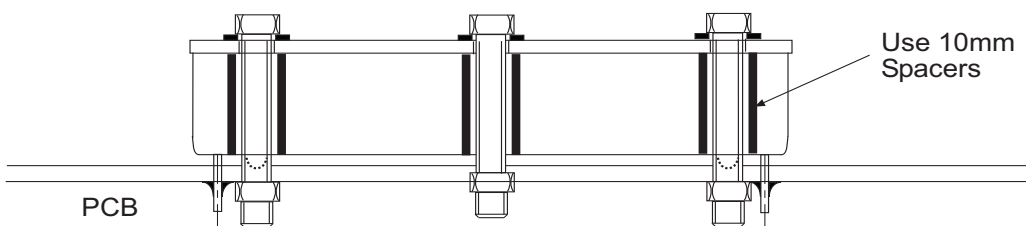

The product information and specifications are subject to change without prior notice. All products are designed for non-safety critical commercial and industrial applications. The Buyer agrees to implement safeguards that anticipate the consequences of any failures that might cause harm, loss of life and/or damage property.

Features

ICE Technology*

- 115°C Maximum Case Temperature
- -40°C Minimum Temp.
- Built-in FCC/EN55022 Class B Filter
- 2:1 Wide Input Voltage Range
- 40 Watts Output Power
- Ribbed or Baseplate Case Styles
- Min. Efficiency of 87%
- 3kVDC Isolation
- Low Quiescent Current

Description

The RPP40 series 2:1 input range DC/DC converters are ideal for high end industrial applications and COTS Military applications where a very wide operating temperature range of -45°C to +120°C is required. Although the case size is very compact, the converter contains a built-in filter EN55022 Class B / FCC Level B without the need for any external components. The RPP40 is available in two case styles: the ribbed case and the baseplate case for high vibration, bulkhead-mounting or for passive cooling applications. They are UL-60950-1 certified.

Selection Guide 24V and 48V Input Types

Part Number	Input Range VDC	Output Voltage VDC	Output Current A	Efficiency ⁽²⁾ (Typ.)
RPP40-243.3S	18-36	3.3	12	87%
RPP40-2405S	18-36	5	8	89%
RPP40-2412S	18-36	12	3.33	87%
RPP40-2415S	18-36	15	2.67	88%
RPP40-2424S	18-36	24	1.67	88%
RPP40-483.3S	36-75	3.3	12	88%
RPP40-4805S	36-75	5	8	89%
RPP40-4812S	36-75	12	3.33	87%
RPP40-4815S	36-75	15	2.67	88%
RPP40-4824S	36-75	24	1.67	88%
RPP40-2412D	18-36	±12	±1.67	87%
RPP40-2415D	18-36	±15	±1.33	88%
RPP40-2424D	18-36	±24	±0.84	88%
RPP40-4812D	36-75	±12	±1.67	87%
RPP40-4815D	36-75	±15	±1.33	88%
RPP40-4824D	36-75	±24	±0.84	88%

** add suffix for case options

SUFFIX INFORMATION

none = Standard Ribbed Case
-B = Baseplate Case

For other CTRL logic (-1), case style (-F) or low temperature options (-L, -M, -T) please contact RECOM for availability.

POWERLINE+

DC/DC-Converter

with 3 year Warranty

RECOM

40 Watt 2:1 Single & Dual Output



**UL-60950-1 Certified
E224736**

RPP40

* ICE Technology

ICE (Innovation in Converter Excellence) uses state-of-the-art techniques to minimise internal power dissipation and to increase the internal temperature limits to extend the ambient operating temperature range to the maximum. Refer to Application Notes

Specifications (typical at nominal input and 25°C unless otherwise noted)

Input Voltage Range	24V nominal input	9-36VDC	
	48V nominal input	18-75VDC	
Under Voltage Lockout	24V input	DC-DC ON (min.)	17.5VDC
		DC-DC OFF (max.)	17VDC
	48V input	DC-DC ON (min.)	35VDC
		DC-DC OFF (max.)	34VDC
Input Filter	Common Mode EMC Filter		
Input Voltage Variation dv/dt (Complies with ETS300 132 part 4.4)	5V/ms max		
Input Surge Voltage (100 ms max.)	24V Input	50VDC	
	48V Input	100VDC	
Input Reflected Ripple	nominal Vin and full load	30mA _{p-p}	
Start Up Time	nominal Vin and constant resistor load	2ms typ., 5ms max.	
Remote ON/OFF ⁽⁴⁾	Logic High	Open or 3.0V < Vr < 5.5V	
	Logic Low	Short or 0V < Vr < 1.2V	
Remote OFF input current	Nominal input	2mA typ.	
Output Power	50W max.		
Output Voltage Accuracy	10% Load and nominal Vin	±1%	
Voltage Adjustability	±10%		
Minimum Load	0%		
Line Regulation	low line, high line at full load	±0.3%	
Load Regulation	10% to 100% full load	±0.5%	
Ripple and Noise (20MHz bandwidth limited) (measured with 1µF capacitor across output)	3.3V, 5V	60mV _{p-p} typ.	
	All others	40mV _{p-p} typ.	
Temperature Coefficient	±0.04%/°C max.		
Transient Response	25% load step change	200µs	
Over Load Protection	% of full load at nominal Vin	120% typ.	
Short Circuit Protection	Power Limit, automatic recovery		
Output Over Voltage Protection (refer to block diagram in Application Notes)	Converter shutdown if Vout > Vout nominal + 20%		
Isolation Voltage	Rated at 2250VDC/1 minute, Flash tested at 3000VDC/1 second		
Isolation Resistance	10MΩ min.		
Isolation Capacitance (refer to block diagram in Application Notes)	3000pF max.		
Operating Frequency	260kHz ± 40kHz Maximum		
Case Temperature	+120°C		
Storage Temperature Range	-55°C to +125°C		
Over Temperature Protection (refer to block diagram in Application Notes)	internal thermistor		
Operating Temperature Range	Ambient, Free Convection	-40°C to to see Calculation (Note 7)	
Thermal Impedance (Natural convection)	Ribbed Case: Vertical	7.3°C/Watt	
	Ribbed Case: Horizontal	10°C/Watt	
Relative Humidity	5% to 95% RH		
Case Material ⁽⁷⁾	Aluminium		
Potting Material	Silicone (UL94-V0)		

continued on next page

Specifications (typical at nominal input and 25°C unless otherwise noted)

Weight	Ribbed Case	39g
	Basrplate Case	43g
Packing Quantity	Ribbed Case	4 pcs per Tube
	Baseplate Case	Single packed
Safety Standards	certified UL-60950-1, 1st Edition	
Thermal Cycling	complies with MIL-STD-810F	
Vibration	10-55Hz, 12G, 30 Min. along X, Y and Z	
Conducted Emissions	EN55022	Class B
Radiated Emissions	EN55022	Class B
ESD	EN61000-4-2	Perf. Criteria B
Radiated Immunity	EN61000-4-3	Perf. Criteria A
Fast Transient ⁽⁵⁾	EN61000-4-4	Perf. Criteria B
Surge ⁽⁵⁾	EN61000-4-5	Perf. Criteria B
Conducted Immunity	EN61000-4-6	Perf. Criteria A
MTBF calculated according to BELLCORE TR-NWT-000332 ⁽⁶⁾	1989 x 10 ³ hours	

Notes :

1. Typical values at nominal input voltage and no load/full load.
2. Mini values at nominal input voltage and full load.
3. The ON/OFF pin voltage is referenced to negative input. The pin is pulled high internally.
ON/OFF control is standard with positive logic: e.g. RPP40-2405S
Positive logic: 0= OFF, 1 = ON. The converter will be ON if the CTRL is left open.
4. Requires an external 100µF low ESR capacitor to meet EN61000-4-4 and EN61000-4-5
5. Case I: 50% Stress, Temperature at 50°C (Ground Benign).
6. To ensure a good all-round electrical contact, the baseplate is pressed firmly into place within the aluminium housing. The hydraulic press can leave tooling marks and deformations to both the housing and baseplate. The case is anodised aluminium, so there will be natural variations in the case colour and the aluminium is not scratch resistant. Any resultant marks, scratches and colour variations are cosmetic only and do not affect the operation or performance of the converters.

7. Example:

$$R_{th\text{case-ambient}} = 7.5^{\circ}\text{C/W (vertical)}$$

$$R_{th\text{case-ambient}} = 11.5^{\circ}\text{C/W (horizontal)}$$

$$R_{th\text{case-ambient}} = \frac{T_{\text{case}} - T_{\text{ambient}}}{P_{\text{dissipation}}}$$

$$P_{\text{dissipation}} = P_{\text{in}} - P_{\text{out}} = \frac{P_{\text{out}}}{\eta} - P_{\text{out}}$$

T_{case} = Case Temperature

T_{ambient} = Environment Temperature

$P_{\text{dissipation}}$ = Internal losses

P_{in} = Input Power

P_{out} = Output Power

η = Efficiency under given Operating Conditions

$R_{th\text{case-ambient}}$ = Thermal Impedance

$$P_{\text{dissipation}} = P_{\text{in}} - P_{\text{out}} = \frac{P_{\text{out}}}{\eta} - P_{\text{out}}$$

Practical Example:

Take the RPP20-1205S with 50% load. What is the maximum ambient operating temperature? Use converter vertical in application.

$$Eff_{\text{min}} = 89\% @ V_{\text{nom}}$$

$$P_{\text{out}} = 20\text{W}$$

$$P_{\text{outapp}} = 20 \times 0.5 = 10\text{W}$$

$$P_{\text{dissipation}} = \frac{P_{\text{out}}}{\eta} - P_{\text{out}}$$

$$\eta = \sim 88\% \text{ (from Eff vs Load Graph)}$$

$$P_{\text{dissipation}} = \frac{10}{0.88} - 10 = 1.36\text{W}$$

$$R_{th} = \frac{T_{\text{casemax}} - T_{\text{ambient}}}{P_{\text{dissipation}}} \rightarrow 7.5^{\circ}\text{C/W} = \frac{115^{\circ}\text{C} - T_{\text{ambient}}}{1.36\text{W}}$$

$$T_{\text{ambient}} = 104.8^{\circ}\text{C}$$

Typical Characteristics

RPP40-4805S

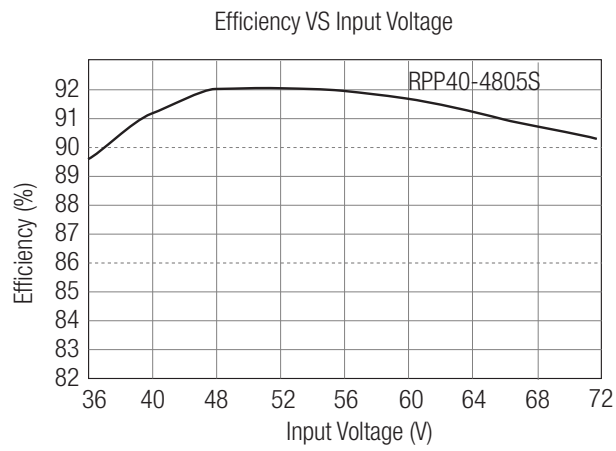

Recommended PCB Layout

Ribbed Case

Single Output

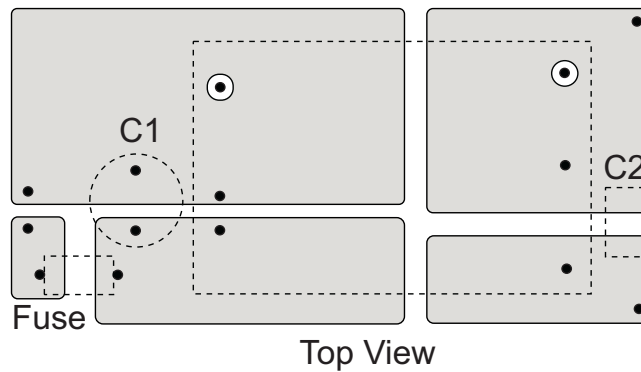

Dual Output

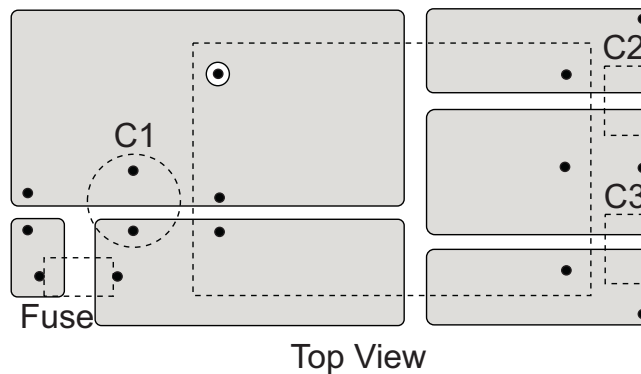

RPP40

Recommended PCB Layout

Baseplate Case- suggested PCB layout

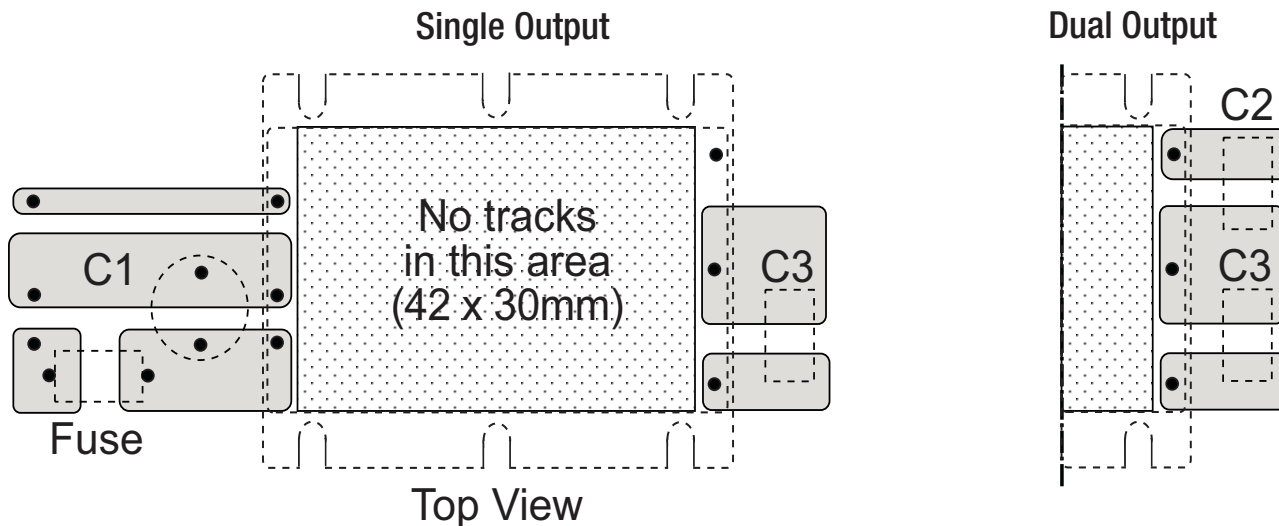

Input Fuse is recommended. Recommended fuse rating = double maximum input current, time delay type.

Input Capacitor, C1, is required to meet EN61000 Surge and Fast Transient, otherwise it is not required for normal operation.

Output Capacitors C2/C3 are recommended, but not required for normal operation. Typical capacitor values are 1µF MLCC

To ensure optimum thermal performance, use large areas of copper on the PCB to assist with heat dissipation and mount the converter vertically.

Package Style and Pinning (mm)

Ribbed Case (Standard - no Suffix)

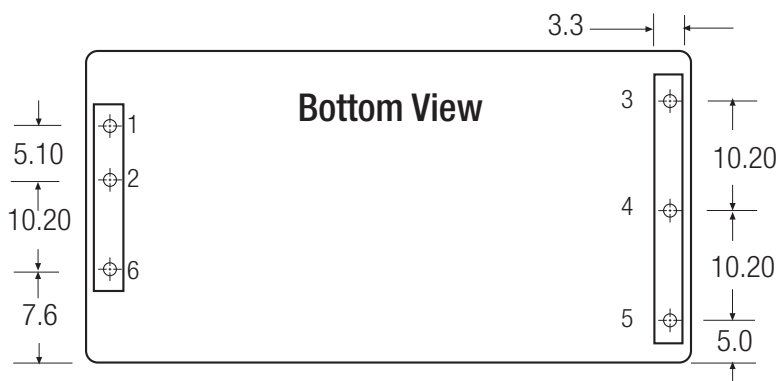
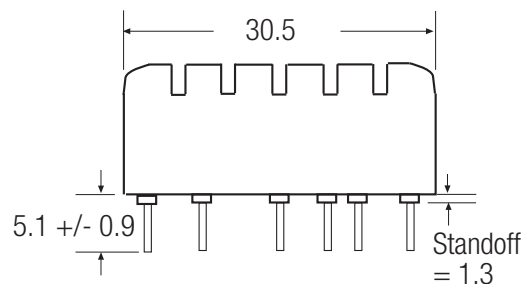
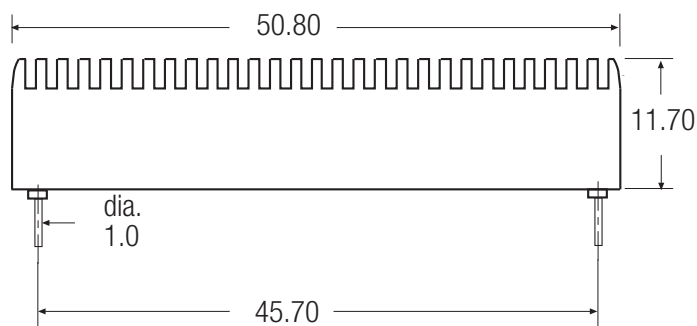

Pin Connections

Pin #	Single	Dual
1	+Vin	+Vin
2	-Vin	-Vin
3	+Vout	+Vout
4	-Vout	Com
5	Trim	-Vout
6	CTRL	CTRL

Pin Pitch Tolerance ±0.35 mm

Typical Characteristics

Baseplate Case (-B Suffix)

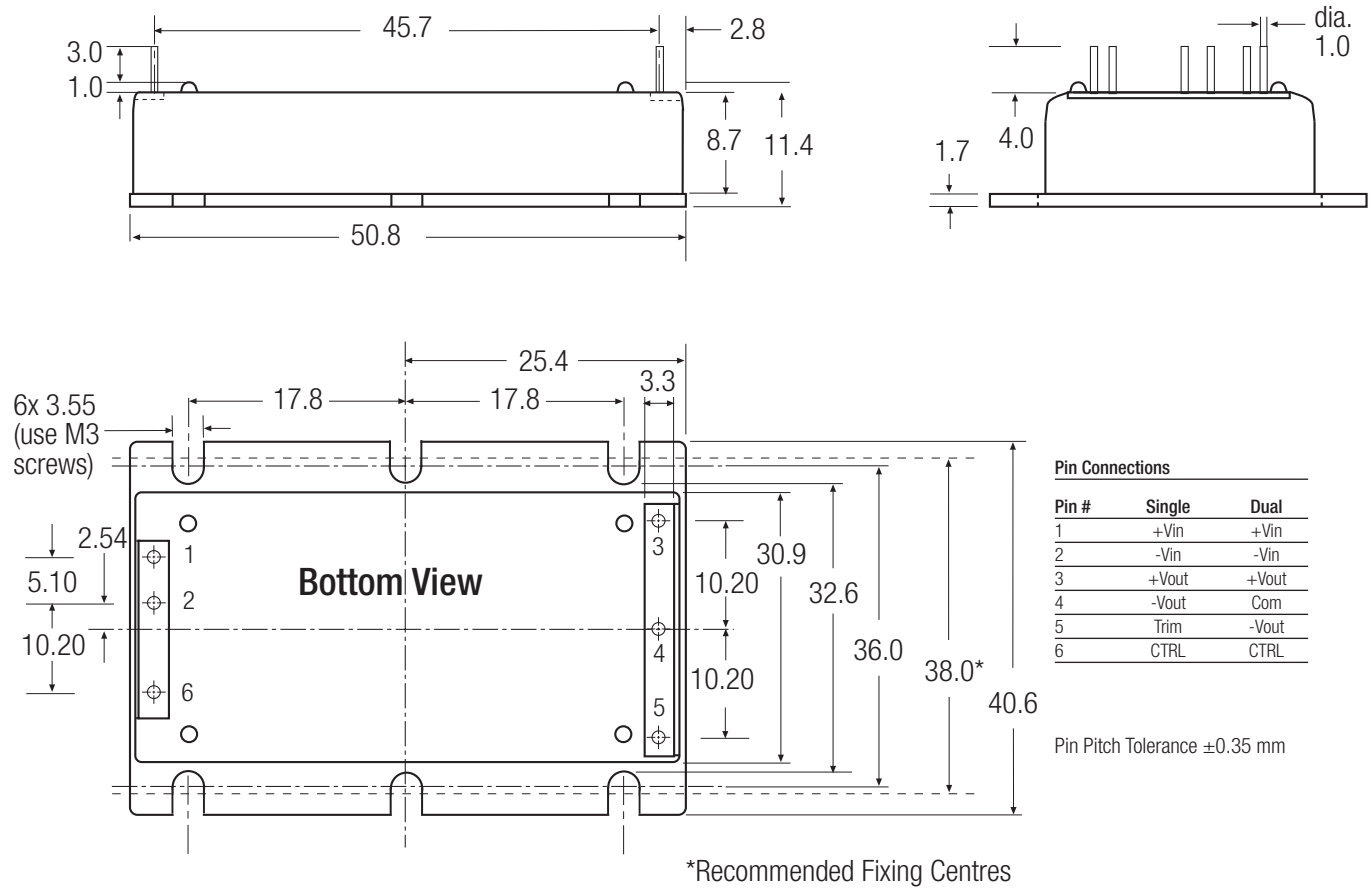

Baseplate Case Fixing - Mounting onto Heatsink/Bulkhead

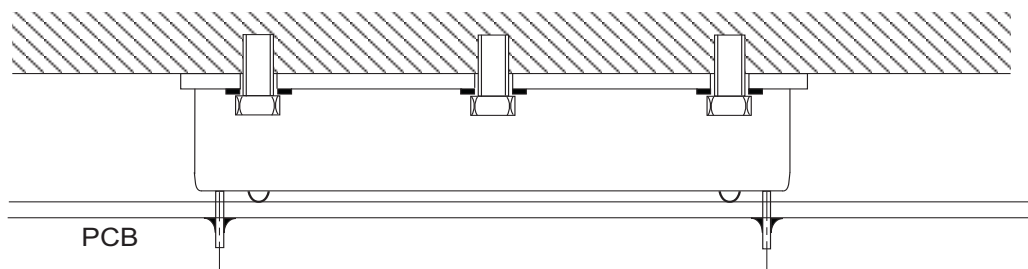

Baseplate Case Fixing - Anti Vibration Mounting onto PCB

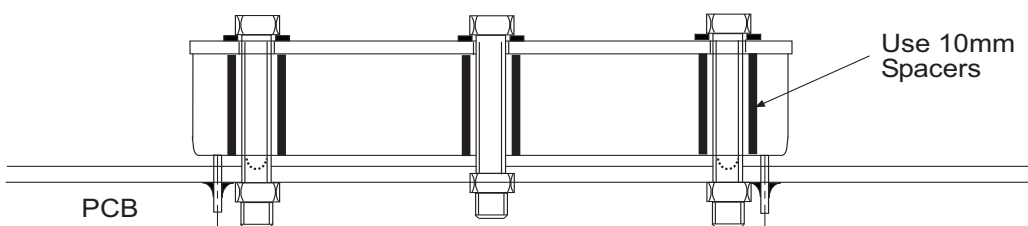

Features

ICE Technology*

- 115°C Maximum Case Temperature
- -40°C Minimum Temp.
- Built-in FCC/EN55022 Class B Filter
- 4:1 Wide Input Voltage Range
- 40 Watts Output Power
- Ribbed or Baseplate Case Styles
- Min. Efficiency 86%
- 3kVDC Isolation
- Low Quiescent Current

Description

The RPP40-W series 4:1 input range DC/DC converters are ideal for high end industrial applications and COTS Military applications where a very wide operating temperature range of -40°C to +115°C is required. Although the case size is very compact, the converter contains a built-in filter EN55022 Class B / FCC Level B without the need for any external components. The RPP40-W is available in two case styles: the ribbed case for active cooling and the baseplate case for high vibration, bulkhead-mounting or for passive heatsink cooling applications. They are UL-60950-1 certified.

Selection Guide 24V and 48V Input Types

Part Number	Input Range VDC	Output Voltage VDC	Output Current A	Input ⁽¹⁾ Current mA	Efficiency ⁽²⁾ (Min.)
RPP40-243.3SW	9-36	3.3	12	58/1896	86%
RPP40-2405SW	9-36	5	8	60/1894	87%
RPP40-2412SW	9-36	12	3.33	100/1894	87%
RPP40-2415SW	9-36	15	2.67	100/1885	87%
RPP40-2424SW	9-36	24	1.67	100/1885	87%
RPP40-483.3SW	18-75	3.3	12	42/946	86%
RPP40-4805SW	18-75	5	8	37/941	87%
RPP40-4812SW	18-75	12	3.33	5/938	87%
RPP40-4815SW	18-75	15	2.67	5/939	87%
RPP40-4824SW	18-75	24	1.67	5/939	87%
RPP40-2412DW	9-36	±12	±1.67	32/1453	87%
RPP40-2415DW	9-36	±15	±1.33	30/1436	87%
RPP40-2424DW	9-36	±24	±0.84	30/1436	87%
RPP40-4812DW	18-75	±12	±1.67	18/727	87%
RPP40-4815DW	18-75	±15	±1.33	20/718	87%
RPP40-4824DW	18-75	±24	±0.84	20/718	87%

** add suffix for case options

SUFFIX INFORMATION

none = Standard Ribbed Case
-B = Baseplate Case

For other CTRL logic (-1), case style (-F) or low temperature options (-L, -M, -T) please contact RECOM for availability.

POWERLINE+

DC/DC-Converter

with 3 year Warranty

RECOM

40 Watt 4:1 Single & Dual Output

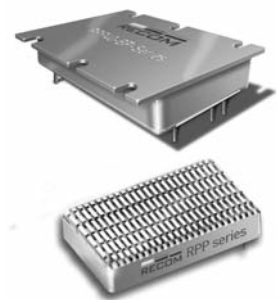

**UL-60950-1 Certified
E224736**

RPP40-W

* ICE Technology

ICE (Innovation in Converter Excellence) uses state-of-the-art techniques to minimise internal power dissipation and to increase the internal temperature limits to extend the ambient operating temperature range to the maximum. Refer to Application Notes

Specifications (typical at nominal input and 25°C unless otherwise noted)

Input Voltage Range	24V nominal input	9-36VDC	
	48V nominal input	18-75VDC	
Under Voltage Lockout	24V input	DC-DC ON (min.)	8.5VDC
		DC-DC OFF (max.)	8VDC
	48V input	DC-DC ON (min.)	17.5VDC
		DC-DC OFF (max.)	17VDC
Input Filter	Common Mode EMC Filter		
Input Surge Voltage (100 ms max.)	24V Input	50VDC	
	48V Input	100VDC	
Input Reflected Ripple	nominal Vin and full load	300mA _{p-p}	
Start Up Time	nominal Vin and constant resistor load	20ms typ., 50ms max.	
Remote ON/OFF ⁽³⁾	Logic High	Open or 3.0V < Vr < 5.5V	
	Logic Low	Short or 0V < Vr < 1.2V	
	Nominal input	2mA typ.	
Remote OFF input current	Nominal input	2mA typ.	
Output Voltage Accuracy	10% Load and nominal Vin	±1%	
Voltage Adjustability		±10%	
Minimum Load		0%	
Line Regulation	low line, high line at full load	±0.3%	
Load Regulation	10% to 100% full load	±0.5%	
Ripple and Noise (20MHz bandwidth limited) (measured with 1µF capacitor across output)	3.3V, 5V	60mV _{p-p} typ.	
	All others	40mV _{p-p} typ.	
Temperature Coefficient		±0.04%/°C max.	
Transient Response	25% load step change	200µs	
Over Load Protection	% of full load at nominal Vin	120% typ.	
Short Circuit Protection		Hiccup, automatic recovery	
Output Over Voltage Protection (refer to block diagram in Application Notes)		Converter shutdown if Vout > Vout nominal + 20%	
Isolation Voltage		Rated at 2250VDC/1 minute, Flash tested at 3000VDC/1 second	
Isolation Resistance		10MΩ min.	
Isolation Capacitance (refer to block diagram in Application Notes)		3000pF max.	
Operating Frequency		260kHz ± 40kHz Maximum	
Case Temperature		+115°C	
Storage Temperature Range		-55°C to +125°C	
Over Temperature Protection (refer to block diagram in Application Notes)		internal thermistor	
RPP40 Operating Temperature Range	Ambient, Free Convection	-40°C to see Calculation (Note 7)	
Thermal Impedance (Natural convection)	Ribbed Case: Vertical	7.3°C/Watt	
	Ribbed Case: Horizontal	10°C/Watt	
Relative Humidity		5% to 95% RH	
Case Material ⁽⁶⁾		Aluminium	
Potting Material		Silicone (UL94-V0)	

continued on next page

Specifications (typical at nominal input and 25°C unless otherwise noted)

Weight	Ribbed Case	39g
	Baseplate Case	43g
Packing Quantity	Ribbed Case	4 pcs per Tube
	Baseplate Case	Single packed
Safety Standards	certified UL-60950-1, 1st Edition	
Thermal Cycling	complies with MIL-STD-810F	
Vibration	10-55Hz, 12G, 30 Min. along X, Y and Z	
Conducted Emissions	EN55022	Class B
Radiated Emissions	EN55022	Class B
ESD	EN61000-4-2	Perf. Criteria B
Radiated Immunity	EN61000-4-3	Perf. Criteria A
Fast Transient ⁽⁴⁾	EN61000-4-4	Perf. Criteria B
Surge ⁽⁴⁾	EN61000-4-5	Perf. Criteria B
Conducted Immunity	EN61000-4-6	Perf. Criteria A
MTBF calculated according to BELLCORE TR-NWT-000332 ⁽⁵⁾	1989 x 10 ³ hours	

Notes :

- Typical values at nominal input voltage and no load/full load.
- Min. values at nominal input voltage and full load.
- The ON/OFF pin voltage is referenced to negative input. The pin is pulled high internally.
ON/OFF control is standard with positive logic: e.g. RPP40-2405SW
Positive logic: 0= OFF, 1 = ON. The converter will be ON if the CTRL is left open.
- Requires an external 100µF low ESR capacitor to meet EN61000-4-4 and EN61000-4-5
- Case I: 50% Stress, Temperature at 50°C (Ground Benign).
- To ensure a good all-round electrical contact, the baseplate is pressed firmly into place within the aluminium housing. The hydraulic press can leave tooling marks and deformations to both the housing and baseplate. The case is anodised aluminium, so there will be natural variations in the case colour and the aluminium is not scratch resistant. Any resultant marks, scratches and colour variations are cosmetic only and do not affect the operation or performance of the converters.
- Example:

$$R_{th\text{case-ambient}} = 7.3^{\circ}\text{C/W (vertical)}$$

$$R_{th\text{case-ambient}} = 11^{\circ}\text{C/W (horizontal)}$$

$$R_{th\text{case-ambient}} = \frac{T_{\text{case}} - T_{\text{ambient}}}{P_{\text{dissipation}}}$$

$$P_{\text{dissipation}} = P_{\text{in}} - P_{\text{out}} = \frac{P_{\text{out}}}{\eta} - P_{\text{out}}$$

T_{case} = Case Temperature
 T_{ambient} = Environment Temperature
 $P_{\text{dissipation}}$ = Internal losses
 P_{in} = Input Power
 P_{out} = Output Power
 η = Efficiency under given Operating Conditions
 $R_{th\text{case-ambient}}$ = Thermal Impedance

$$P_{\text{dissipation}} = P_{\text{in}} - P_{\text{out}} = \frac{P_{\text{out}}}{\eta} - P_{\text{out}}$$

Practical Example:

Take the RPP40-2405SW with 80% load. What is the maximum ambient operating temperature? Use converter vertical in application.

$$Eff_{\text{min}} = 87\% @ V_{\text{nom}}$$

$$P_{\text{out}} = 40\text{W}$$

$$P_{\text{outapp}} = 40 \times 0.80 = 32\text{W}$$

$$P_{\text{dissipation}} = \frac{P_{\text{out}}}{\eta} - P_{\text{out}}$$

$$\eta = \sim 88\% \text{ (from Eff vs Load Graph)}$$

$$P_{\text{dissipation}} = \frac{32}{0.88} - 32 = 4.36\text{W}$$

$$R_{th} = \frac{T_{\text{casemax}} - T_{\text{ambient}}}{P_{\text{dissipation}}} \rightarrow 7.3^{\circ}\text{C/W} = \frac{115^{\circ}\text{C} - T_{\text{ambient}}}{4.36\text{W}}$$

$$T_{\text{ambient}} = 83.15^{\circ}\text{C}$$

Typical Characteristics

External Output Trimming
Refer to Application Notes for suggested Resistor Values

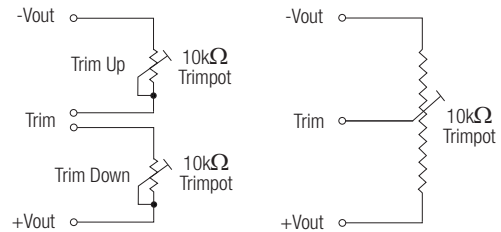

RPP40-2405SW / RPP40-2412SW

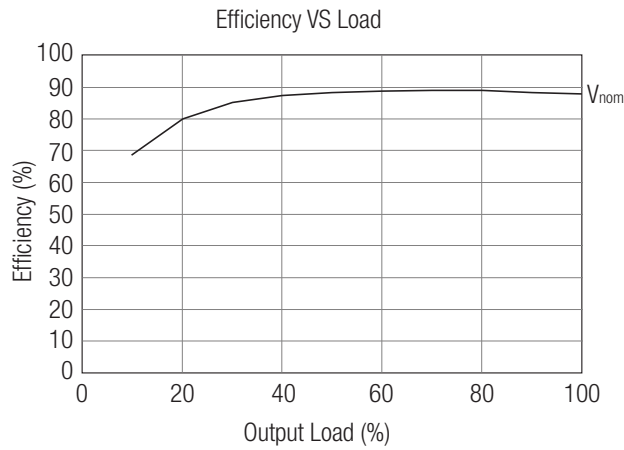

RPP40-W

Recommended PCB Layout

Ribbed Case

Single Output

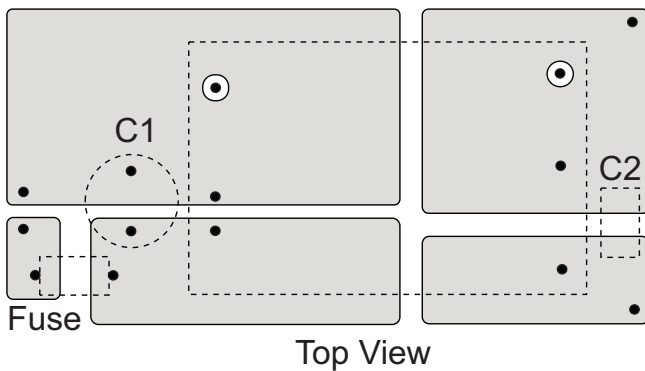

Dual Output

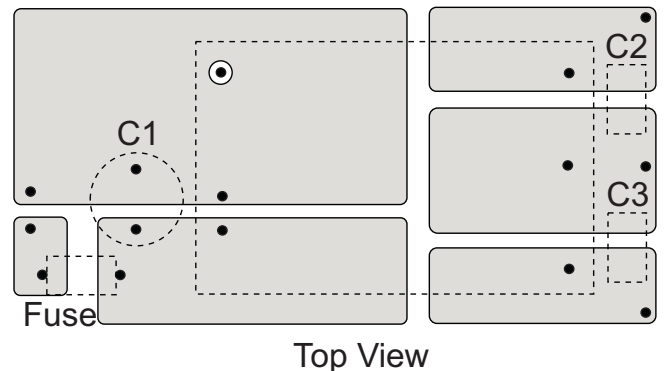

Recommended PCB Layout

Baseplate Case- suggested PCB layout

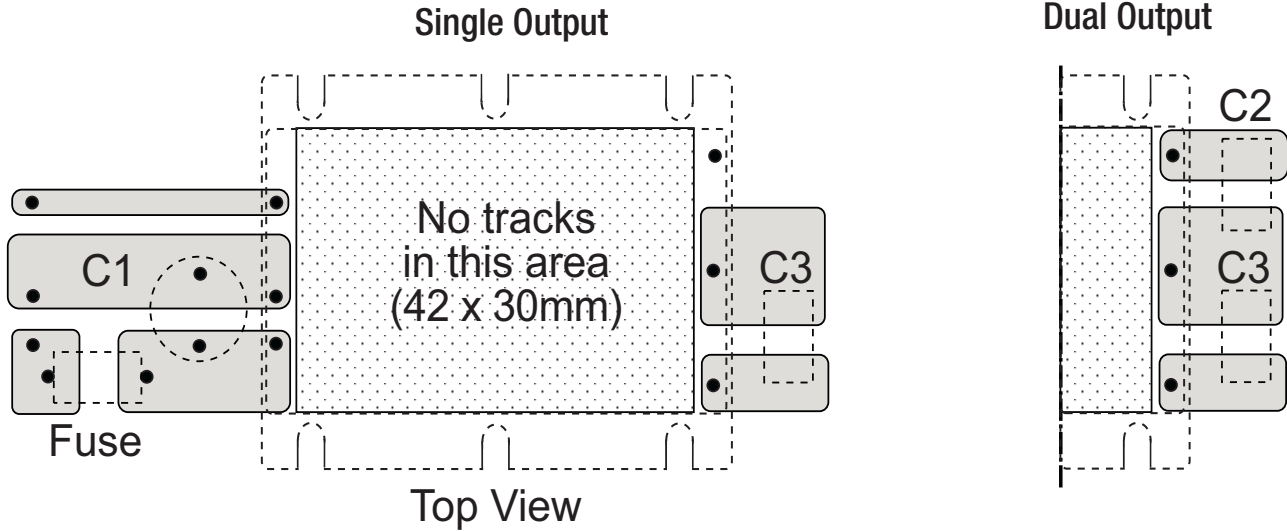

Input Fuse is recommended. Recommended fuse rating = double maximum input current, time delay type.

Input Capacitor, C1, is required to meet EN61000 Surge and Fast Transient, otherwise it is not required for normal operation.

Output Capacitors C2/C3 are recommended, but not required for normal operation. Typical capacitor values are 1µF MLCC

To ensure optimum thermal performance, use large areas of copper on the PCB to assist with heat dissipation and mount the converter vertically.

Package Style and Pinning (mm)

Ribbed Case (Standard - no Suffix)

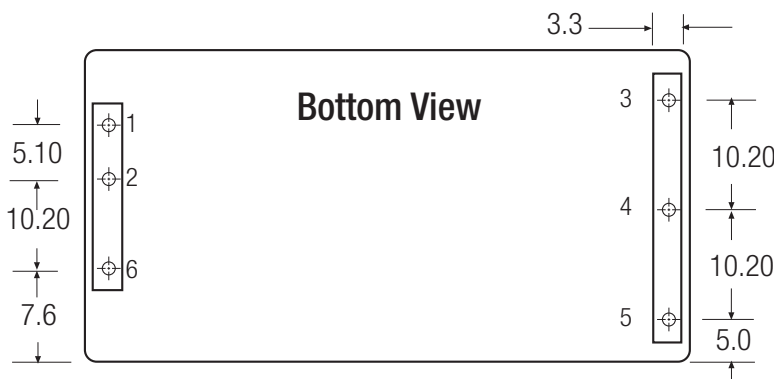
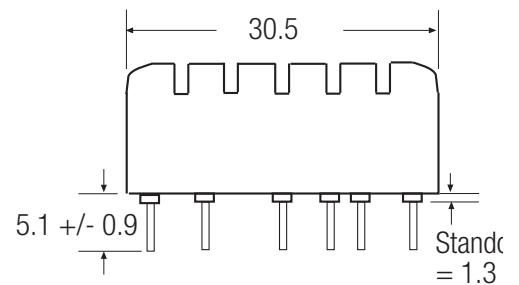
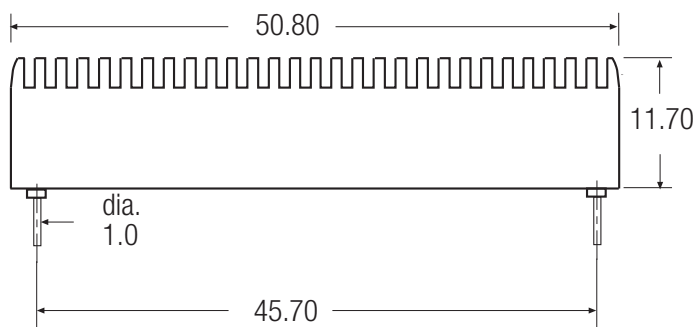

Pin Connections

Pin #	Single	Dual
1	+Vin	+Vin
2	-Vin	-Vin
3	+Vout	+Vout
4	-Vout	Com
5	Trim	-Vout
6	CTRL	CTRL

Pin Pitch Tolerance ±0.35 mm

Typical Characteristics

Baseplate Case (-B Suffix)

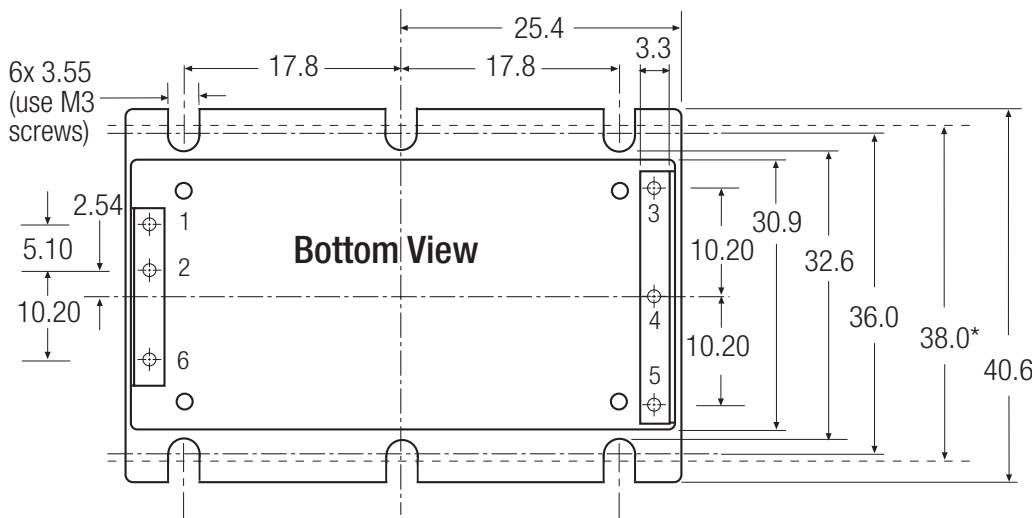
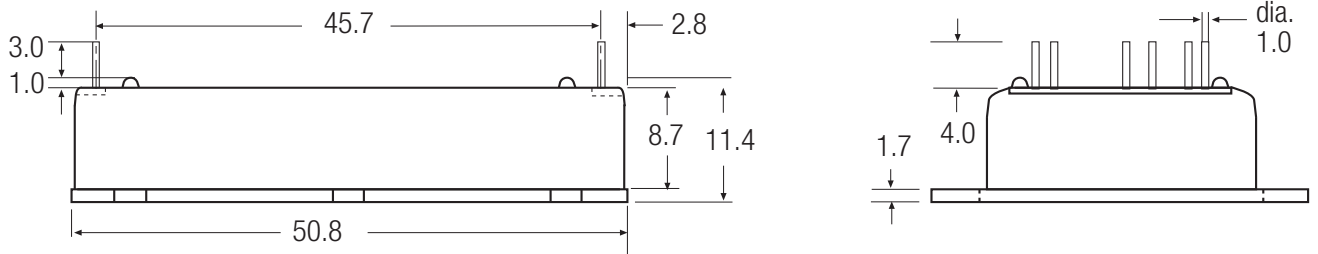

Pin Connections

Pin #	Single	Dual
1	+Vin	+Vin
2	-Vin	-Vin
3	+Vout	+Vout
4	-Vout	Com
5	Trim	-Vout
6	CTRL	CTRL

Pin Pitch Tolerance ± 0.35 mm

*Recommended Fixing Centres

Baseplate Case Fixing - Mounting onto Heatsink/Bulkhead

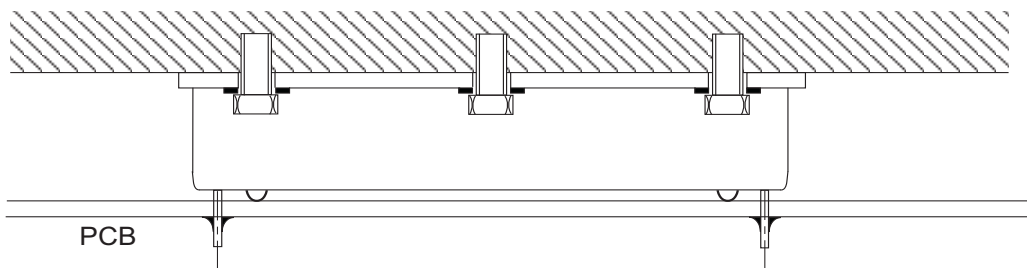

Baseplate Case Fixing - Anti Vibration Mounting onto PCB

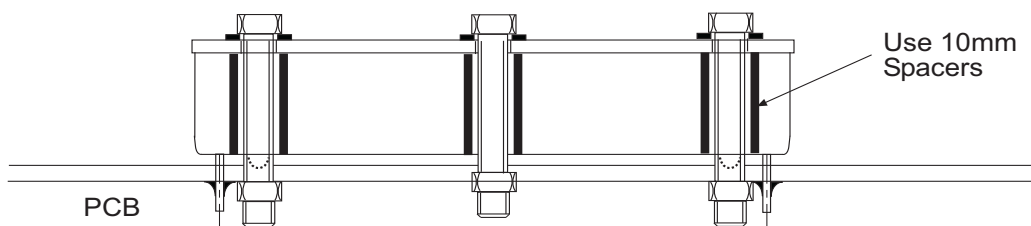

The product information and specifications are subject to change without prior notice. All products are designed for non-safety critical commercial and industrial applications. The Buyer agrees to implement safeguards that anticipate the consequences of any failures that might cause harm, loss of life and/or damage property.

Features

ICE Technology*

- 115°C Maximum Case Temperature
- -40°C Minimum Temp.
- Built-in FCC/EN55022 Class B Filter
- 2:1 Wide Input Voltage Range
- 50 Watts Output Power
- Ribbed or Baseplate Case Styles
- Min. Efficiency 86%
- 3kVDC Isolation
- Low Quiescent Current

Description

The RPP50 series 2:1 input range DC/DC converters are ideal for high end industrial applications and COTS Military applications where a very wide operating temperature range of -45°C to +120°C is required. Although the case size is very compact, the converter contains a built-in filter EN55022 Class B / FCC Level B without the need for any external components. The RPP50 is available in two case styles: the ribbed case for active cooling and the baseplate case for high vibration, bulkhead-mounting or for passive heatsink cooling applications. They are UL-60950-1 certified.

Selection Guide 24V and 48V Input Types

Part Number	Input Range VDC	Output Voltage VDC	Output Current A	Input ⁽¹⁾ Current mA	Efficiency ⁽²⁾ (Typ.)
RPP50-243.3S	18-36	3.3	15	58/2405	86%
RPP50-2405S	18-36	5	10	60/2315	89%
RPP50-2412S	18-36	12	4.16	18/2370	87%
RPP50-2415S	18-36	15	3.33	18/2315	88%
RPP50-2424S	18-36	24	2.10	18/2315	88%
RPP50-483.3S	36-75	3.3	15	42/1177	87%
RPP50-4805S	36-75	5	10	37/1140	89%
RPP50-4812S	36-75	12	4.16	11/1165	87%
RPP50-4815S	36-75	15	3.33	11/1141	88%
RPP50-4824S	36-75	24	2.10	11/1141	88%

** add suffix for case options

SUFFIX INFORMATION

none = Standard Ribbed Case
-B = Baseplate Case

For other CTRL logic (-1), case style (-F) or low temperature options (-L, -M, -T) please contact RECOM for availability.

POWERLINE+

DC/DC-Converter

with 3 year Warranty

RECOM

50 Watt 2:1 Single Output



UL-60950-1 Certified
E224736

RPP50-S

* ICE Technology

ICE (Innovation in Converter Excellence) uses state-of-the-art techniques to minimise internal power dissipation and to increase the internal temperature limits to extend the ambient operating temperature range to the maximum. Refer to Application Notes

Specifications (typical at nominal input and 25°C unless otherwise noted)

Input Voltage Range	24V nominal input	18-36VDC	
	48V nominal input	36-75VDC	
Under Voltage Lockout	24V input	DC-DC ON (min.)	17.5VDC
		DC-DC OFF (max.)	17VDC
	48V input	DC-DC ON (min.)	35VDC
		DC-DC OFF (max.)	34VDC
Input Filter	Common Mode EMC Filter		
Input Surge Voltage (100 ms max.)	24V Input	50VDC	
	48V Input	100VDC	
Input Reflected Ripple	nominal Vin and full load	300mA _{p-p}	
Start Up Time	nominal Vin and constant resistor load	20ms typ., 50ms max.	
Remote ON/OFF ⁽³⁾	Logic High	Open or 3.0V < Vr < 5.5V	
	Logic Low	Short or 0V < Vr < 1.2V	
Remote OFF input current	Nominal input	2mA typ.	
Output Voltage Accuracy	10% Load and nominal Vin	±1%	
Voltage Adjustability		±10%	
Minimum Load		0%	
Line Regulation	low line, high line at full load	±0.3%	
Load Regulation	10% to 100% full load	±0.5%	
Ripple and Noise (20MHz bandwidth limited) (measured with 1µF capacitor across output)	3.3V, 5V	60mV _{p-p} typ.	
	All others	40mV _{p-p} typ.	
Temperature Coefficient		±0.04%/°C max.	
Transient Response	25% load step change	200µs	
Over Load Protection	% of full load at nominal Vin	120% typ.	
Short Circuit Protection		Hiccup, automatic recovery	
Output Over Voltage Protection (refer to block diagram in Application Notes)		Converter shutdown if Vout > Vout nominal + 20%	
Isolation Voltage	Rated at 2250VDC/1 minute, Flash tested at 3000VDC/1 second		
Isolation Resistance		10MΩ min.	
Isolation Capacitance (refer to block diagram in Application Notes)		3000pF max.	
Operating Frequency		260kHz ± 40kHz Maximum	
Case Temperature		+115°C	
Storage Temperature Range		-55°C to +125°C	
Over Temperature Protection (refer to block diagram in Application Notes)		internal thermistor	
RPP50 Operating Temperature Range	Ambient, Free Convection	-40°C to see Calculation (Note 7)	
Thermal Impedance (Natural convection)	Ribbed Case: Vertical	7.3°C/Watt	
	Ribbed Case: Horizontal	10°C/Watt	
Relative Humidity		5% to 95% RH	
Case Material ⁽⁶⁾		Aluminium	
Potting Material		Silicone (UL94-V0)	
Weight	Ribbed Case	39g	
	Baseplate Case	43g	
Packing Quantity	Ribbed Case	4 pcs per Tube	
	Baseplate Case	Single packed	

Specifications (typical at nominal input and 25°C unless otherwise noted)

Safety Standards	certified UL-60950-1, 1st Edition	
Thermal Cycling	complies with MIL-STD-810F	
Vibration	10-55Hz, 12G, 30 Min. along X, Y and Z	
Conducted Emissions	EN55022	Class B
Radiated Emissions	EN55022	Class B
ESD	EN61000-4-2	Perf. Criteria B
Radiated Immunity	EN61000-4-3	Perf. Criteria A
Fast Transient ⁽⁴⁾	EN61000-4-4	Perf. Criteria B
Surge ⁽⁴⁾	EN61000-4-5	Perf. Criteria B
Conducted Immunity	EN61000-4-6	Perf. Criteria A
MTBF calculated according to BELLCORE TR-NWT-000332 ⁽⁵⁾	1989 x 10 ³ hours	

Notes :

1. Typical values at nominal input voltage and no load/full load.
2. Typical values at nominal input voltage and full load.
3. The ON/OFF pin voltage is referenced to negative input. The pin is pulled high internally.
ON/OFF control is standard with positive logic: e.g.RPP50-4805S.
Positive logic: 0= OFF, 1 = ON. The converter will be ON if the CTRL is left open.
4. Requires an external 100µF low ESR capacitor to meet EN61000-4-4 and EN61000-4-5
5. Case I: 50% Stress, Temperature at 50°C (Ground Benign).
6. To ensure a good all-round electrical contact, the baseplate is pressed firmly into place within the aluminium housing. The hydraulic press can leave tooling marks and deformations to both the housing and baseplate. The case is anodised aluminium, so there will be natural variations in the case colour and the aluminium is not scratch resistant. Any resultant marks, scratches and colour variations are cosmetic only and do not affect the operation or performance of the converters.

7. Example:

$$R_{th\text{case-ambient}} = 7.3^{\circ}\text{C/W (vertical)}$$

$$R_{th\text{case-ambient}} = 11^{\circ}\text{C/W (horizontal)}$$

$$R_{th\text{case-ambient}} = \frac{T_{\text{case}} - T_{\text{ambient}}}{P_{\text{dissipation}}}$$

$$P_{\text{dissipation}} = P_{\text{in}} - P_{\text{out}} = \frac{P_{\text{out}}}{\eta} - P_{\text{out}}$$

T_{case} = Case Temperature
 T_{ambient} = Environment Temperature
 $P_{\text{dissipation}}$ = Internal losses
 P_{in} = Input Power
 P_{out} = Output Power
 η = Efficiency under given Operating Conditions
 $R_{th\text{case-ambient}}$ = Thermal Impedance

$$P_{\text{dissipation}} = P_{\text{in}} - P_{\text{out}} = \frac{P_{\text{out}}}{\eta} - P_{\text{out}}$$

Practical Example:

Take the RPP50-4805SW with 90% load. What is the maximum ambient operating temperature? Use converter vertical in application.

$$Eff_{\text{min}} = 89\% @ V_{\text{nom}}$$

$$P_{\text{out}} = 50\text{W}$$

$$P_{\text{outapp}} = 50 \times 0.9 = 45\text{W}$$

$$P_{\text{dissipation}} = \frac{P_{\text{out}}}{\eta} - P_{\text{out}}$$

$$\eta = \sim 90\% \text{ (from Eff vs Load Graph)}$$

$$P_{\text{dissipation}} = \frac{45}{0.9} - 45 = 5\text{W}$$

$$R_{th} = \frac{T_{\text{casemax}} - T_{\text{ambient}}}{P_{\text{dissipation}}} \rightarrow 7.3^{\circ}\text{C/W} = \frac{115^{\circ}\text{C} - T_{\text{ambient}}}{5\text{W}}$$

$$T_{\text{ambient}} = 78.5^{\circ}\text{C}$$

Typical Characteristics

External Output Trimming

Refer to Application Notes for suggested Resistor Values

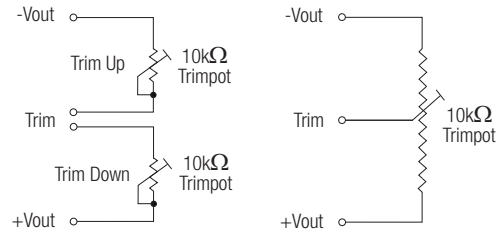

RPP50-4805S

Efficiency VS Load

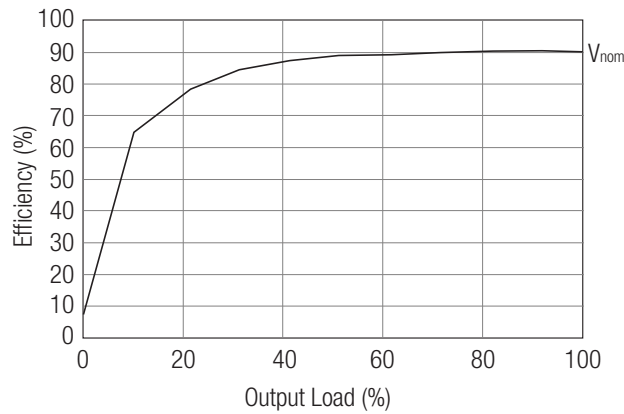

RPP50

Recommended PCB Layout

Ribbed Case

Single Output

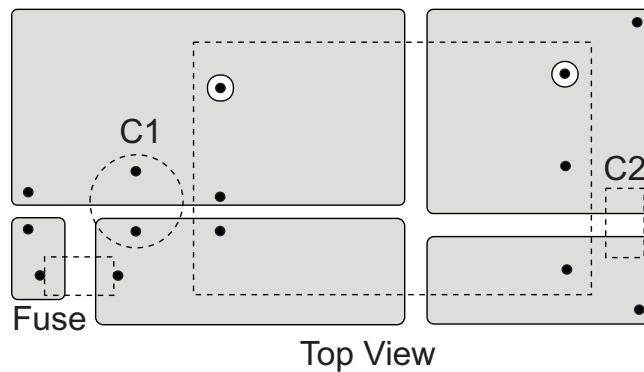

Recommended PCB Layout

Baseplate Case- suggested PCB layout

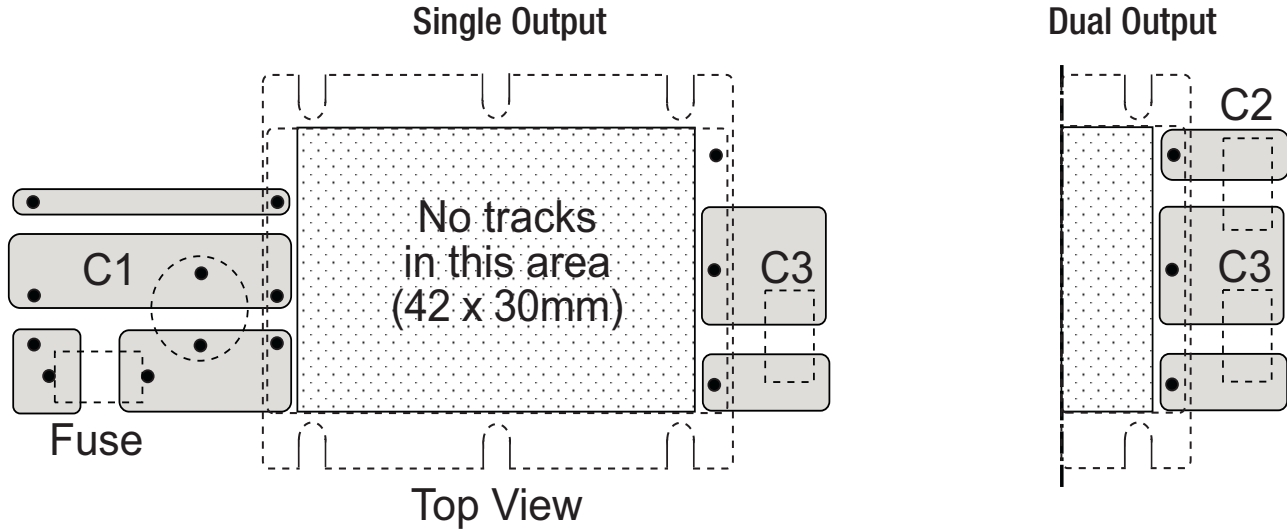

Input Fuse is recommended. Recommended fuse rating = double maximum input current, time delay type.

Input Capacitor, C1, is required to meet EN61000 Surge and Fast Transient, otherwise it is not required for normal operation.

Output Capacitors C2/C3 are recommended, but not required for normal operation. Typical capacitor values are 1µF MLCC

To ensure optimum thermal performance, use large areas of copper on the PCB to assist with heat dissipation and mount the converter vertically.

Package Style and Pinning (mm)

Ribbed Case (Standard - no Suffix)

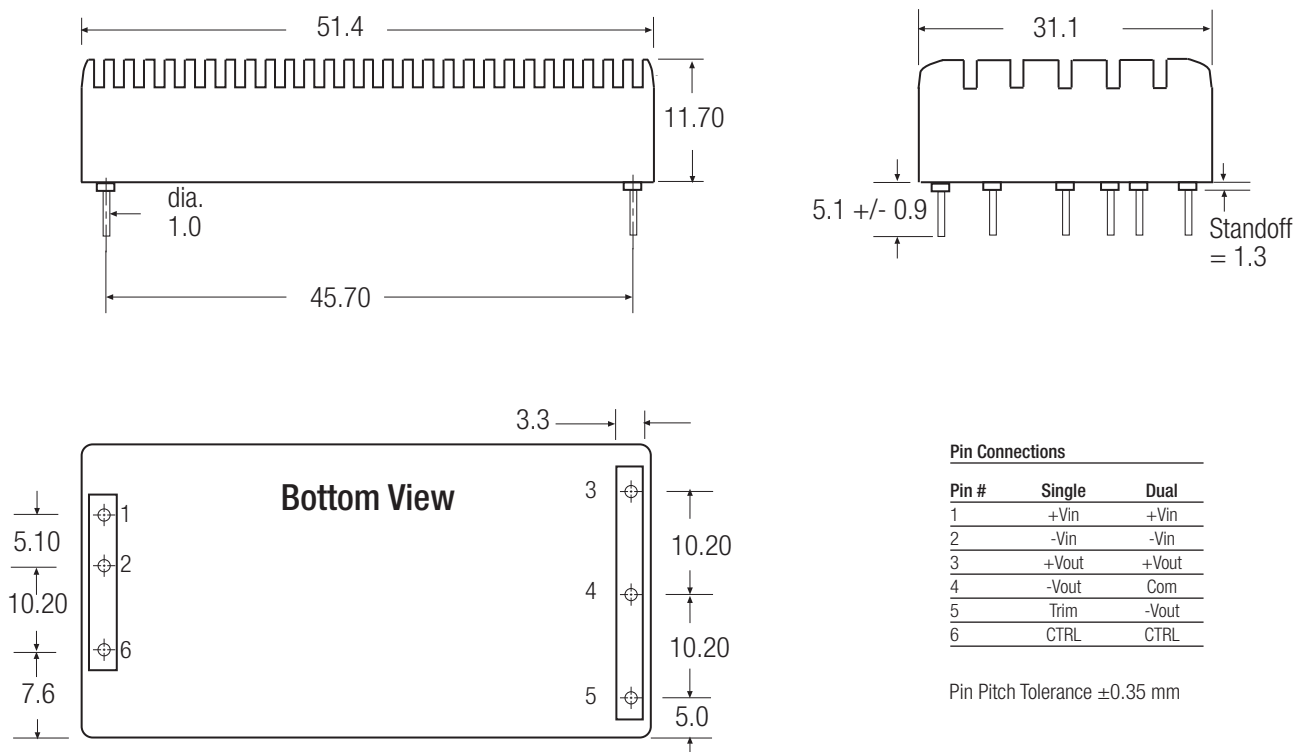

RPP50

Typical Characteristics

Baseplate Case (-B Suffix)

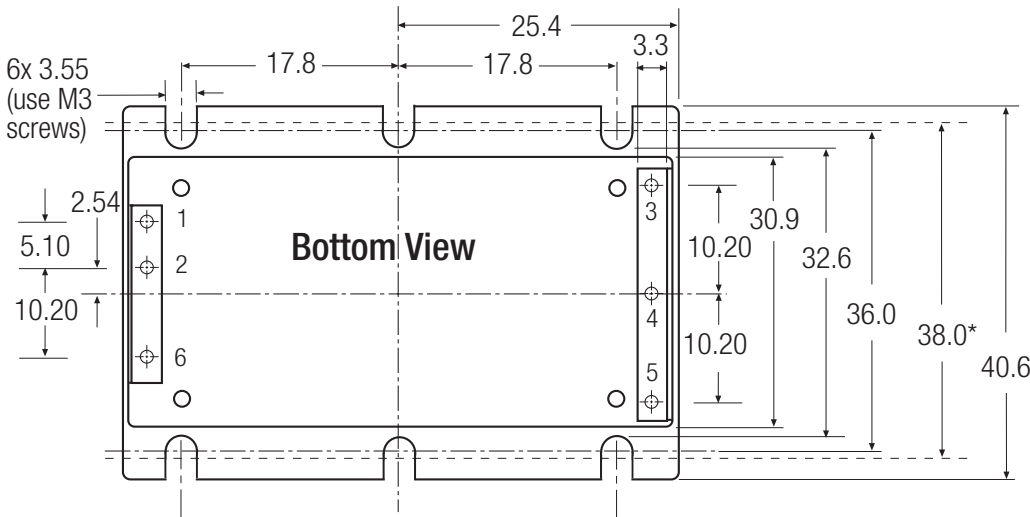
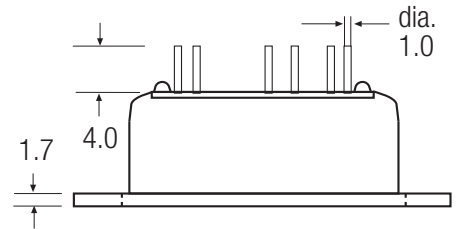
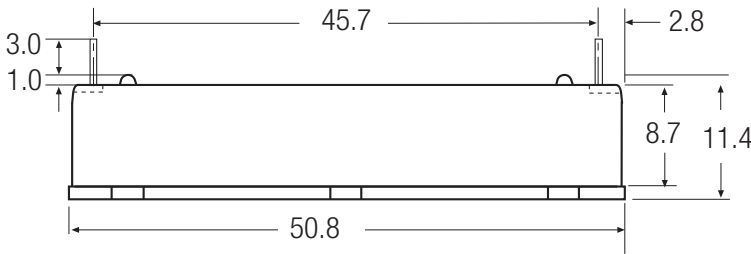

Pin Connections

Pin #	Single	Dual
1	+Vin	+Vin
2	-Vin	-Vin
3	+Vout	+Vout
4	-Vout	Com
5	Trim	-Vout
6	CTRL	CTRL

Pin Pitch Tolerance ± 0.35 mm

*Recommended Fixing Centres

RPP50

Baseplate Case Fixing - Mounting onto Heatsink/Bulkhead

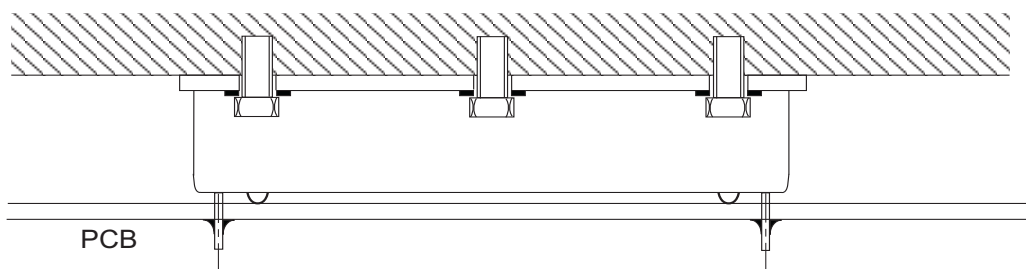

Baseplate Case Fixing - Anti Vibration Mounting onto PCB

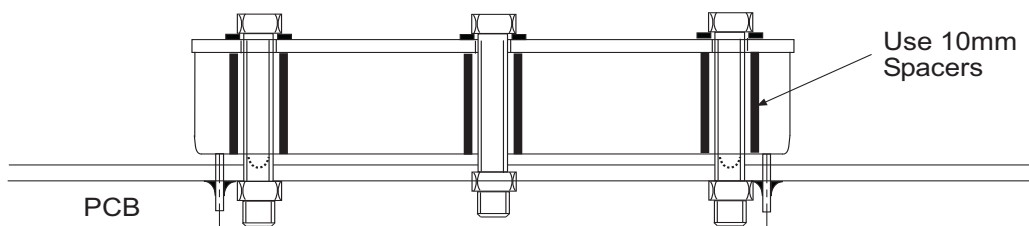

ICE Technology

I.C.E Technology

ICE (Innovation in Converter Excellence) Technology uses a combination of techniques to minimise internal heat dissipation and maximise the heat transfer to ambient to create a new converter series which offers high end performance at a price which is significantly lower than conventional specialist converters.

The exact details of this technology must remain secret, but the following brief resume describes the main features of this technological breakthrough:

Minimising internal heat dissipation

The difference between the input power and the output power is the internal power dissipation which generates heat within the converter.

If the converter is inefficient at converting power, then adding external heat sinks, base-plates or fans are remedies that cure the symptoms rather than address the illness.

First and foremost, the converter must have the highest possible efficiency over the entire input voltage range and load conditions. Most power converters are designed to be most efficient at 25°C, full load and nominal input voltage and thus offer a compromise performance when lightly loaded or operated at the maximum ambient temperature.

ICE Technology uses state-of-the-art techniques to improve power conversion efficiency by approximately 2% compared to standard converters. A two per cent improvement may not sound much, but the difference between a converter with 88% efficiency and one with 90% efficiency is a 17% reduction in the dissipated power. In addition, when lightly loaded, the converters enter a power saving mode and draw only a few milliamps from the supply.

Maximising heat transfer

The rate of heat transfer between a hot body and its cooler surroundings is given by Fourier's Law:

$$q = -k \cdot \Delta T$$

where

q = rate of heat transfer

k = thermal conductivity

and ΔT = temperature difference

If k can be made larger, then the rate of heat transfer can still match or exceed the rate of heat generation at lower temperature differences ΔT and the converter will have an extended operating temperature range.

Techniques to improve thermal conductivity

ICE Technology splits the thermal conductivity problem into two areas and attacks each area separately using different techniques.

Firstly, the internal heat transfer to the case is maximised by a combination of novel converter construction and clever thermal design.

ICE converters use a construction where the hottest components (the switching FET, the transformer and the synchronous rectification FETs) are placed closest to the case wall. This method of construction makes the manufacture of the converter more difficult, but this lack of compromise reduces greatly the internal thermal impedance.

Secondly, the rate of transfer of heat to the surroundings is improved by a novel case construction which incorporates a built-in heat sink. The case is also made from thick aircraft grade aluminium rather than thin nickel-plated copper to provide a better thermal junction between the case and the high thermal conductivity silicone potting material used inside the converter.

Maximising high temperature performance

The final technique used in the construction of ICE Technology converters is to use high temperature internal components. The maximum operating temperature of a converter is dependent on the lowest maximum permissible operating temperature of any the components used. If the capacitors are rated up to +85°C and the FETs are rated at +160°C, then the limiting factor is the capacitor temperature of +85°C.

The temperature of the ferrite core used in the transformer is also an important limiting factor. If the transformer core temperature exceeds the Curie temperature of the ferrite, then the transformer rapidly loses performance.

ICE Technology converter uses high temperature grade components to permit a case temperature of +115°C maximum. This allows operation at up to +85°C ambient without the need for fans to blow air over the converter.



Electromagnetic Compatibility

Although high temperature performance is a significant feature of ICE Technology design, it does not end there.

ICE Technology also addresses the need for electromagnetic compatibility by incorporating a built-in EN55022 Class B grade filter inside the converter. The converter has been designed from the ground up to meet EMC requirements rather than a conventional design process where first the converter is optimised for performance and then an external filter is added to combat the conducted interference.

By including the filter on the main PCB of the converter, the track path lengths and impedances between the filter and the noise-generating components are reduced to the minimum and consequently smaller value filter components can be used that fit into the compact case dimensions of the Powerline+ converters without compromising on filter performance.

Safety and Protection

ICE Technology converters are fully protected from output short circuits, overload, output over-voltage and over-temperature. In addition, they feature under-voltage lockout that will automatically disable the converter if the input voltage falls below the minimum level.

The output is current limited which means that temporary overloads can occur without the converter shutting down. When overloaded, the output voltage will decrease to keep the maximum power constant. For the 40W and 50W converters, if the overload is too high, the converter will go into hiccup short circuit protection mode. In this mode, the converter will attempt to reconnect power every 10-20 milliseconds.

Output overvoltage protection is monitored by a separate and independent feedback circuit and an internal thermistor sensor is used to protect the converter against overheating.

Powerline Plus Output Trim Tables



Output Voltage Trimming:

Single output Powerline Plus converters offer the feature of trimming the output voltage over a certain range around the nominal value by using external trim resistors.

No general equation can be given for calculating the trim resistors, but the

following trimtables give typical values for choosing these trimming resistors.

If voltages between the given trim points are required, extrapolate between the two nearest given values to work out the resistor required or use a variable resistor to set the output voltage.

RPPxx-xx3.3S (all types)

Trim up	1	2	3	4	5	6	7	8	9	10	%
V _{out} =	3,333	3,366	3,399	3,432	3,465	3,498	3,531	3,564	3,597	3,63	Volts
R _U =	72.8	34.4	21.2	14.4	9.9	7.2	5.3	3.88	2.74	1.84	KOhms
Trim down	1	2	3	4	5	6	7	8	9	10	%
V _{out} =	3,267	3,234	3,201	3,168	3,135	3,102	3,069	3,036	3,003	2,97	Volts
R _D =	101.3	36.2	21.0	13.65	9.2	6.0	4.12	2.56	1.34	0.87	KOhms

RPPxx-xx05S (all types)

Trim up	1	2	3	4	5	6	7	8	9	10	%
V _{out} =	5,05	5,1	5,15	5,2	5,25	5,3	5,35	5,4	5,45	5,5	Volts
R _U =	109.7	51	31.2	20.3	14.2	9.87	7.1	5.0	3.38	2.08	KOhms
Trim down	1	2	3	4	5	6	7	8	9	10	%
V _{out} =	4,95	4,9	4,85	4,8	4,75	4,7	4,65	4,6	4,55	4,5	Volts
R _D =	127.6	55.8	33.0	20.2	14.2	9.46	5.97	3.6	1.77	0.28	KOhms

RPPxx-xx12S (all types)

Trim up	1	2	3	4	5	6	7	8	9	10	%
V _{out} =	12,12	12,24	12,36	12,48	12,6	12,72	12,84	12,96	13,08	13,2	Volts
R _U =	270	120	70	45.2	30.1	19.8	12.8	7.52	3.31	0	KOhms
Trim down	1	2	3	4	5	6	7	8	9	10	%
V _{out} =	11,88	11,76	11,64	11,52	11,4	11,28	11,16	11,04	10,92	10,8	Volts
R _D =	270	120	70	45.2	30.1	19.8	12.8	7.52	3.31	0	KOhms

RPPxx-xx15S (all types)

Trim up	1	2	3	4	5	6	7	8	9	10	%
V _{out} =	15,15	15,3	15,45	15,6	15,75	15,9	16,05	16,2	16,35	16,5	Volts
R _U =	337	150	87	56.2	37.5	24.7	16	9.4	4.16	0	KOhms
Trim down	1	2	3	4	5	6	7	8	9	10	%
V _{out} =	14,85	14,7	14,55	14,4	14,25	14,1	13,95	13,8	13,65	13,5	Volts
R _D =	337	150	87	56.2	37.5	24.7	16	9.4	4.16	0	KOhms

Powerline Plus Output Trim Tables

RPPxx-xx24S (all types)

Trim up	1	2	3	4	5	6	7	8	9	10	%
V _{out} =	24,24	24,48	24,72	24,96	25,20	25,44	24,68	25,92	26,16	26,4	Volts
R _U =	270	120	70	45.2	30.1	19.8	12.8	7.52	3.31	0	KOhms
Trim down	1	2	3	4	5	6	7	8	9	10	%
V _{out} =	23,76	23,52	23,28	23,04	22,80	22,56	22,32	22,08	21,84	21,6	Volts
R _D =	270	120	70	45.2	30.1	19.8	12.8	7.52	3.31	0	KOhms

Block Diagrams

Single Output - 3.3V and 5V Outputs

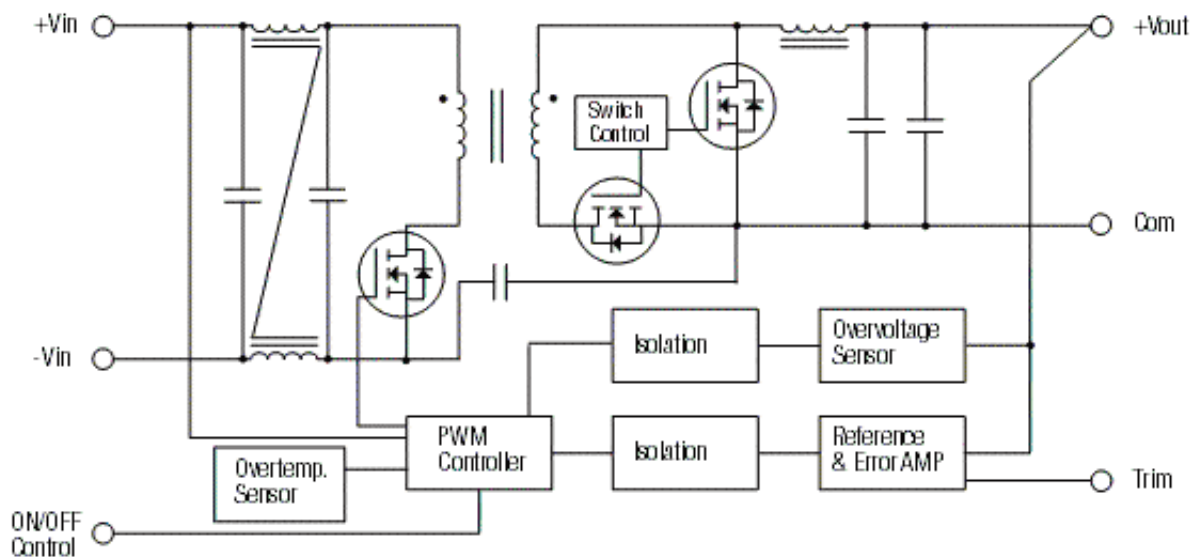

Single Output - all other outputs

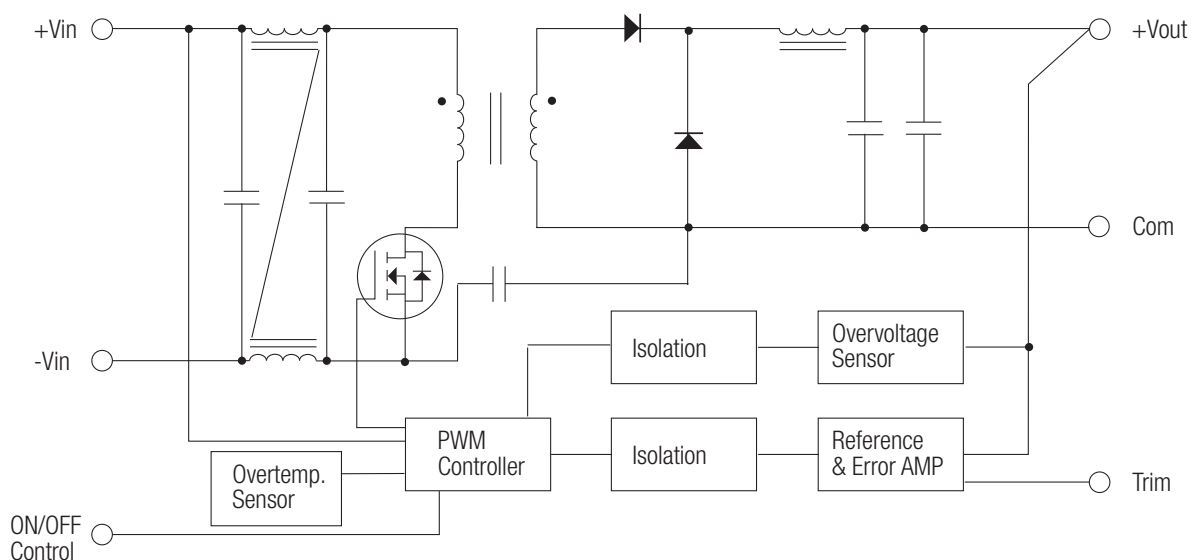

Block Diagrams

Dual Output

